

# Assembly | Asambla | Assemblage

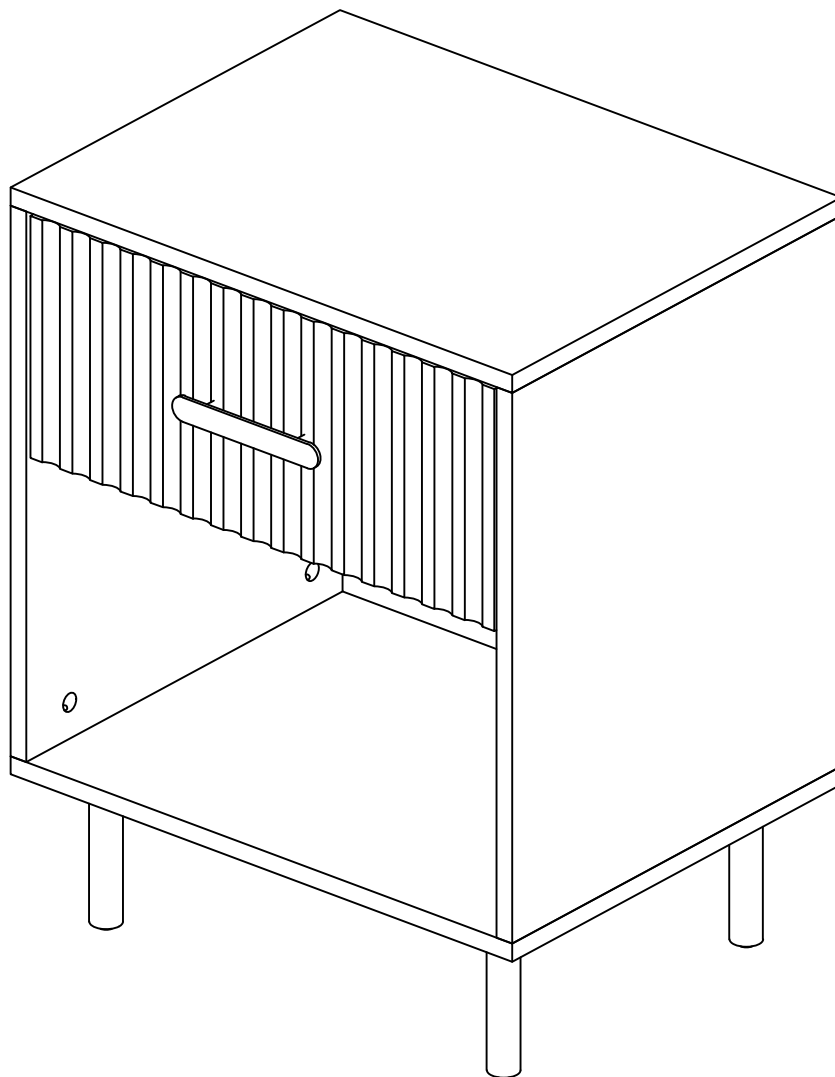

# Assembly | Asamblea | Assemblage

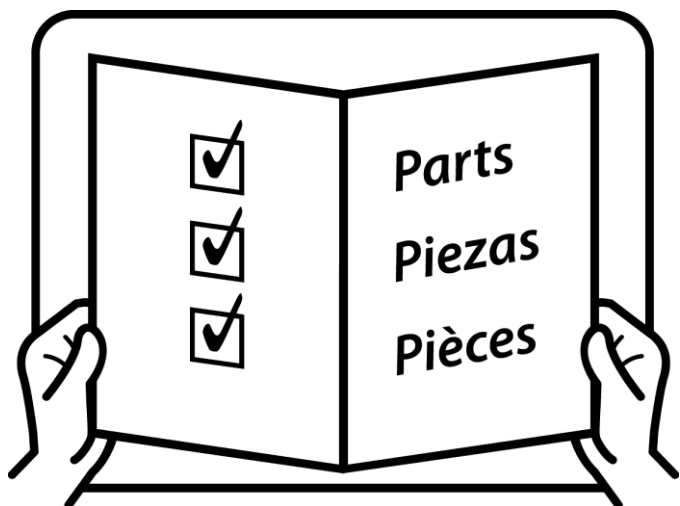
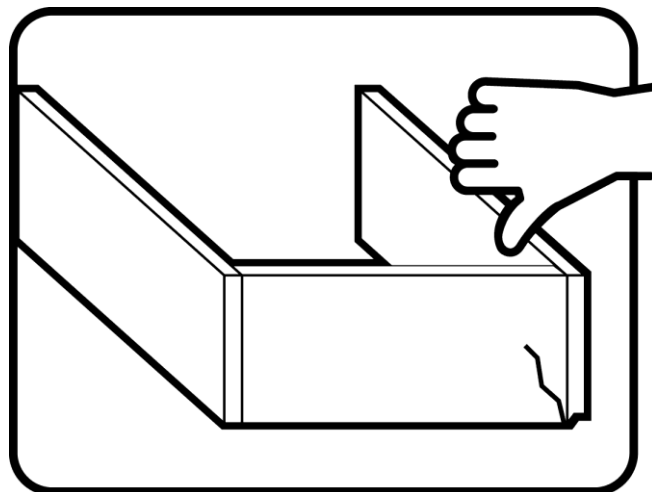
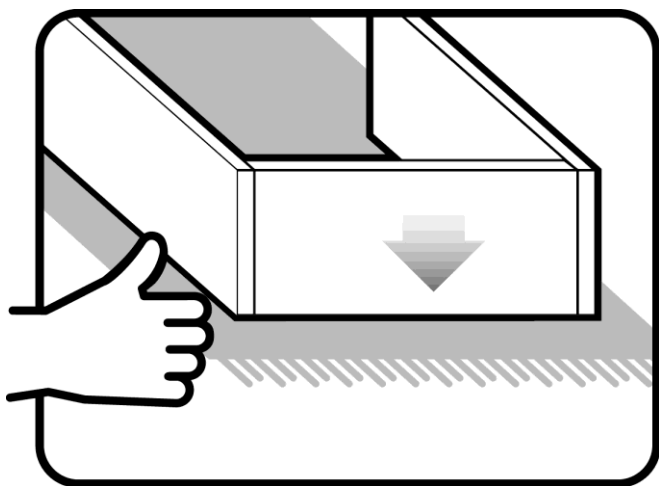
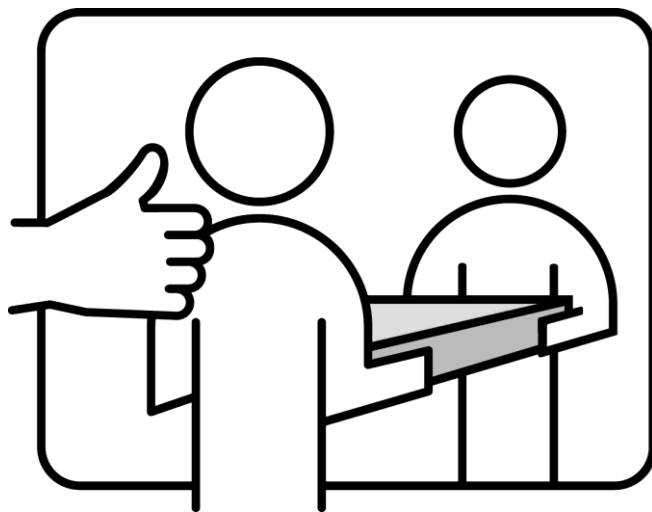
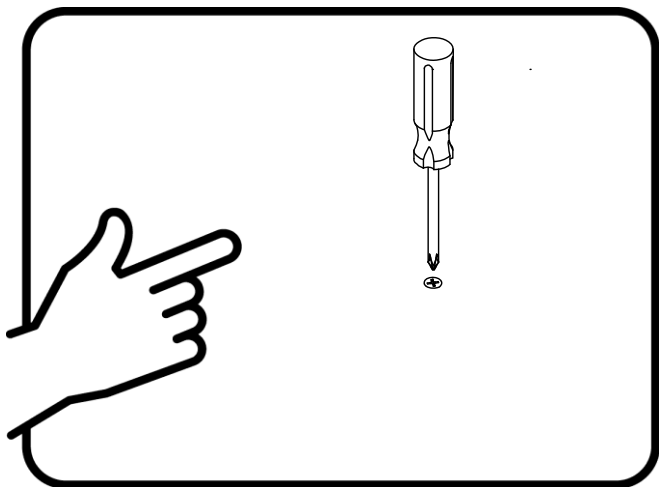

# Assembly | Asamblea | Assemblage

Techniques | Técnicas | Techniques

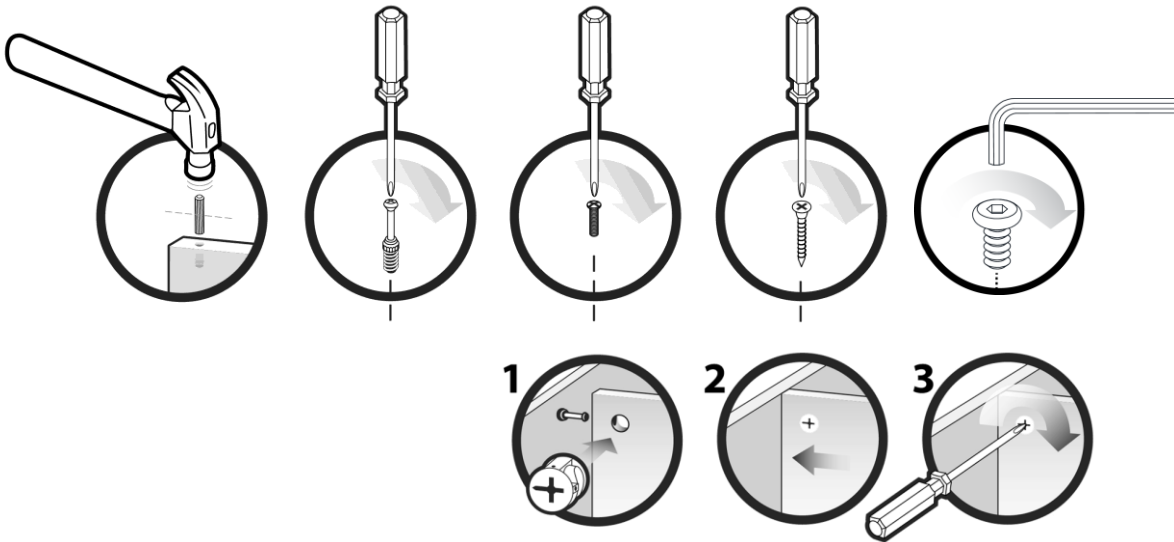

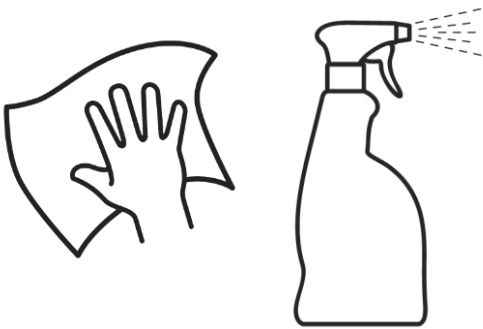

Care | Cuidado | Entretien







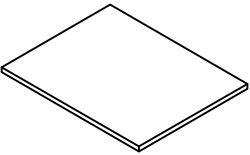
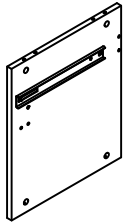
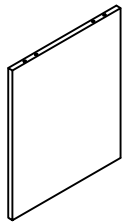
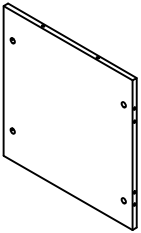
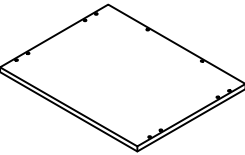
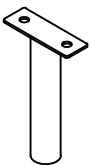

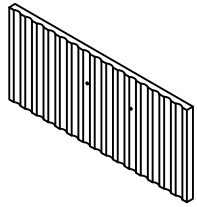
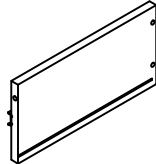
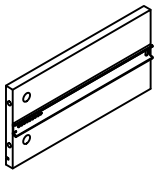
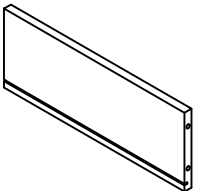
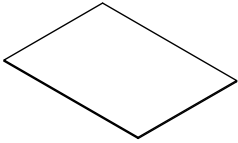
Safety | Seguridad | Sécurité

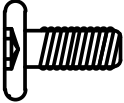

# Assembly | Asamblea | Assemblage

<p>A</p> <p>Quantity of 1</p>  <p>Top Panel Panel superior Panneau supérieur</p>	<p>B</p> <p>Quantity of 1</p>  <p>Left Side Panel Panel lateral izquierdo Panneau latéral gauche</p>	<p>C</p> <p>Quantity of 1</p>  <p>Right Side Panel Panel lateral derecho Panneau latéral droit</p>
<p>D</p> <p>Quantity of 1</p>  <p>Back Panel Panel trasero Panneau arrière</p>	<p>E</p> <p>Quantity of 1</p>  <p>Bottom Panel Panel inferior Panneau inférieur</p>	<p>F</p> <p>Quantity of 4</p>  <p>Metal Legs Patas de metal Pieds en métal</p>
<p>G</p> <p>Quantity of 1</p>  <p>Front Rail Riel delantero Rail avant</p>	<p>H</p> <p>Quantity of 1</p>  <p>Drawer-Face panel Panel Drawer-Face Panneau de façade du tiroir</p>	<p>I</p> <p>Quantity of 1</p>  <p>Drawer-Left Side Panel Cajón-Panel lateral izquierdo Tiroir-Panneau latéral gauche</p>
<p>J</p> <p>Quantity of 1</p>  <p>Drawer-Right Side Panel Cajón-Panel lateral derecho Tiroir-Panneau latéral droit</p>	<p>K</p> <p>Quantity of 1</p>  <p>Drawer-Back panel Panel cajón-trasero Panneau de tiroir</p>	<p>L</p> <p>Quantity of 1</p>  <p>Drawer-Bottom panel Panel inferior del cajón Panneau inférieur du tiroir</p>

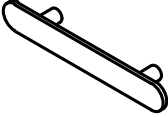
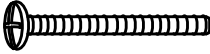
# Assembly | Asamblea | Assemblage

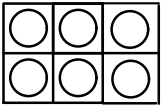
<p>1. Quantity of 22</p>  <p>Cam Lock Bloqueo de leva Serrure à came</p>	<p>2. Quantity of 22</p>  <p>Cam Bolt Perno de leva Boulon à came</p>	<p>3. Quantity of 18</p>  <p>Wooden Dowel Taco de madera Cheville en bois</p>
<p>4. Quantity of 8</p>  <p>Hex Bolt Perno hexagonal Boulon hexagonal</p>	<p>5. Quantity of 8</p>  <p>Lock Washer Arandela de seguridad Rondelle</p>	<p>6. Quantity of 8</p>  <p>Flat Washer Arandela plana Rondelle plate</p>
<p>7. Quantity of 1</p>  <p>Handle Asa Manche</p>	<p>8. Quantity of 2</p>  <p>Handle Screw Tornillo de mango Vis de poignée</p>	<p>9. Quantity of 1</p>  <p>Allen Key Llave Allen Clé Allen</p>
<p>10. Quantity of 1</p>  <p>Covers Cubre Couvre</p>		

# Assembly | Asambla | Assemblage

How to



Cam lock

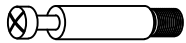

Cam bolt

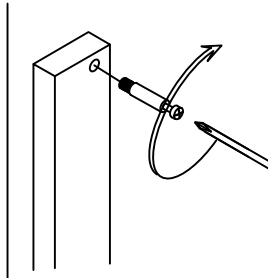

1. Screw Cam Bolt into panel until plastic sleeve is touching wood

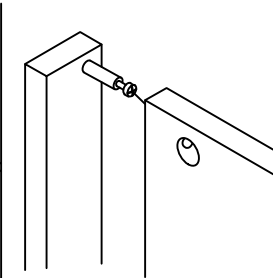

2. Insert Cam bolt into bolt hole of joining panel

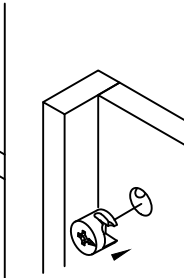

3. Insert cam lock with arrow facing bolt

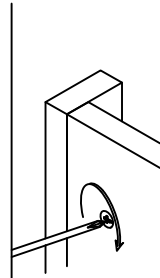

4. Gently turn cam lock 180° clockwise to lock into position

1

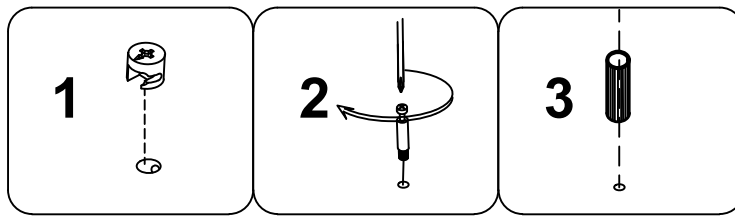

1		06
2		06
3		06

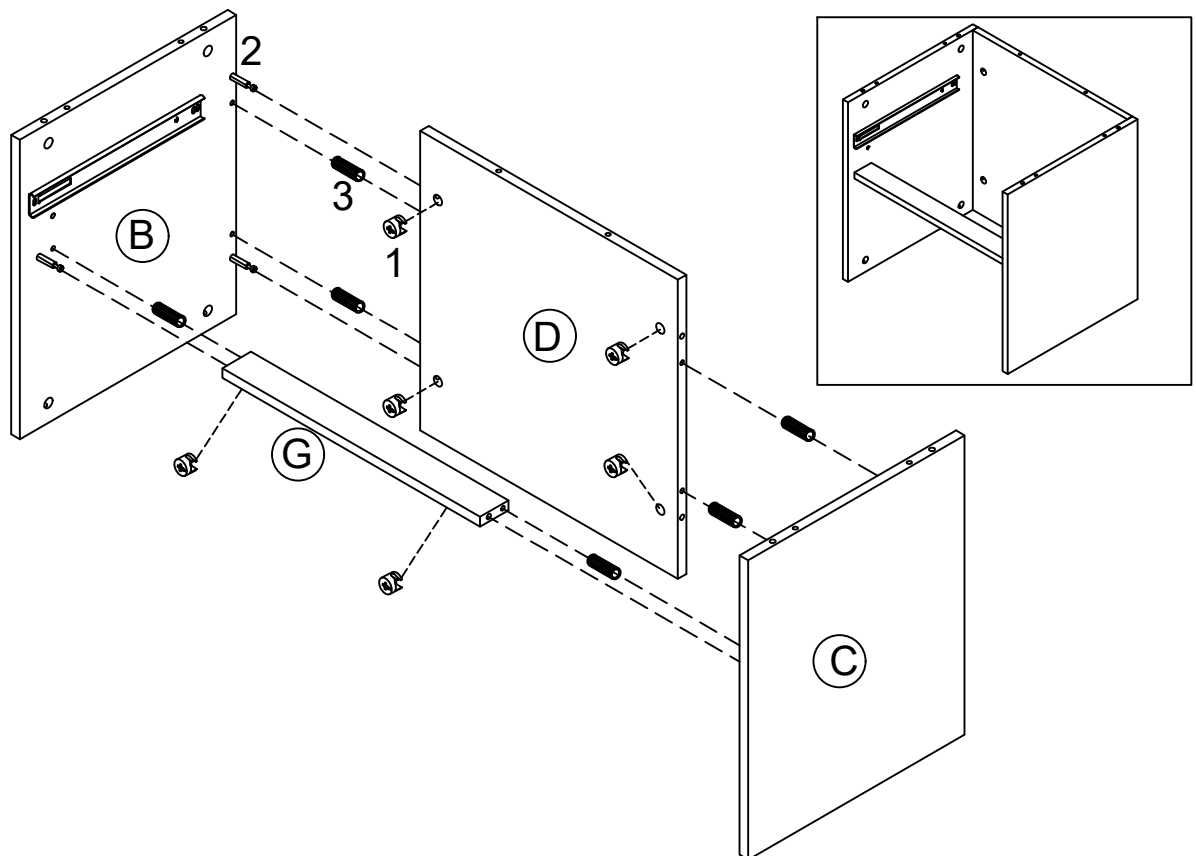

# Assembly | Asambla | Assemblage

2

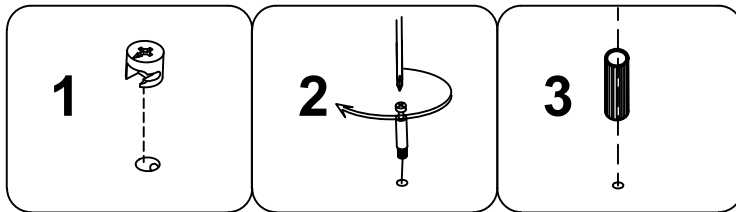



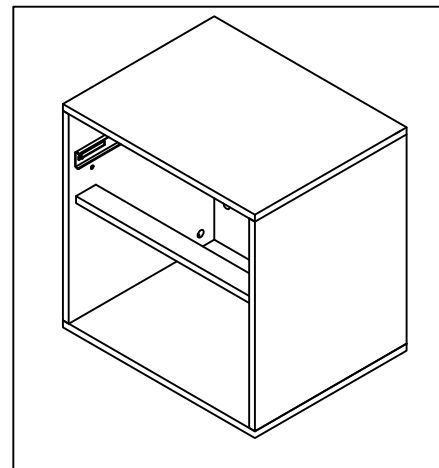
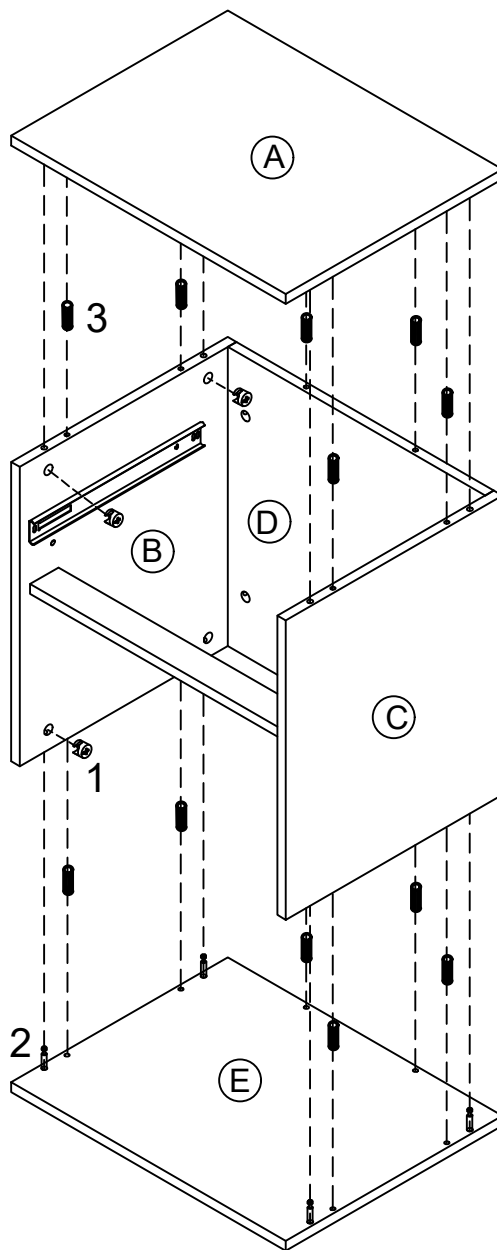

1		8
2		8
3		12

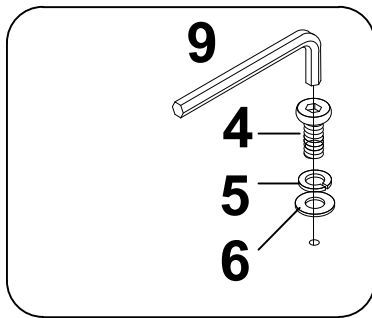

# Assembly | Asambla | Assemblage

3



4		8
5		8
6		8
9		1

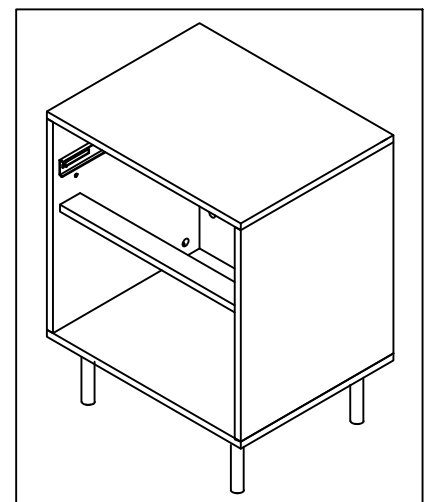
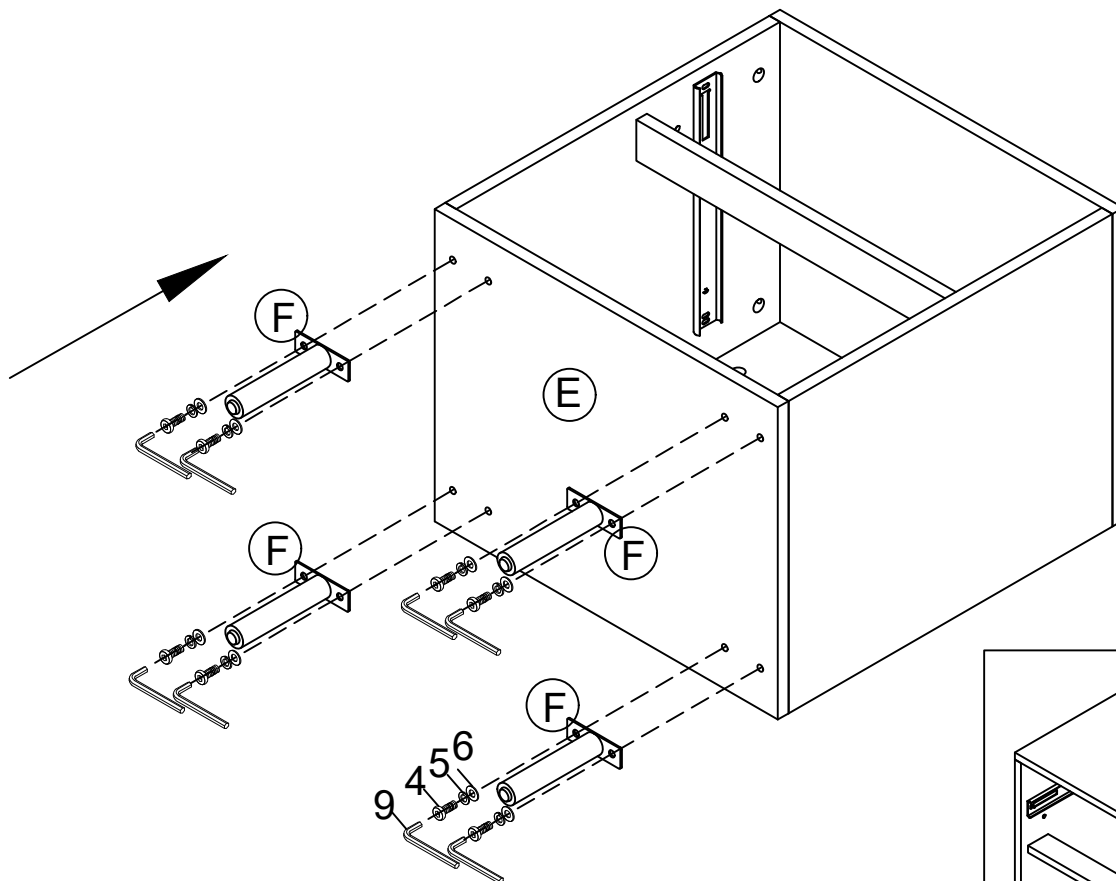

# Assembly | Asambla | Assemblage

4

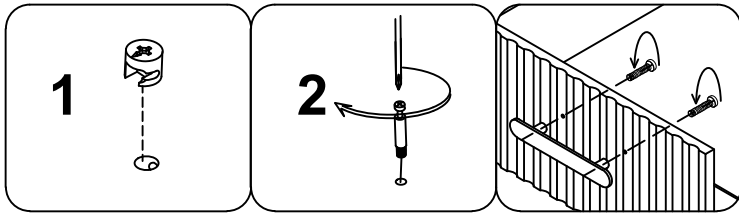

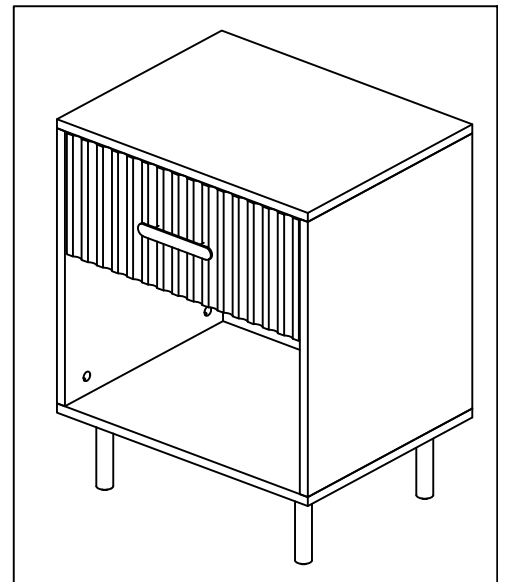
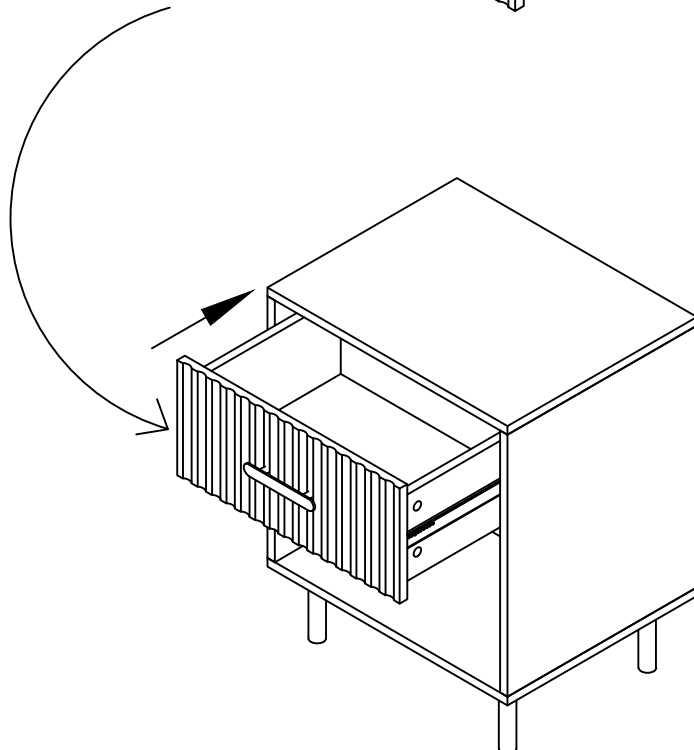
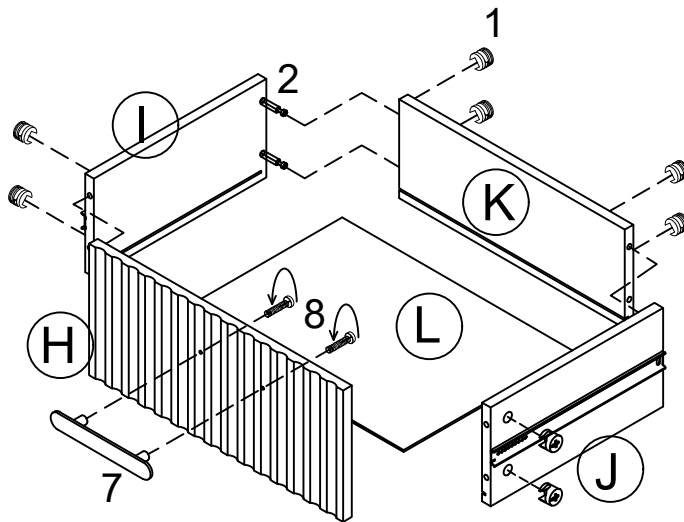

1		8
2		8
7		1
8		2

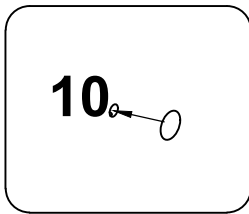

# Assembly | Asambla | Assemblage

5



10		1
----	---	---

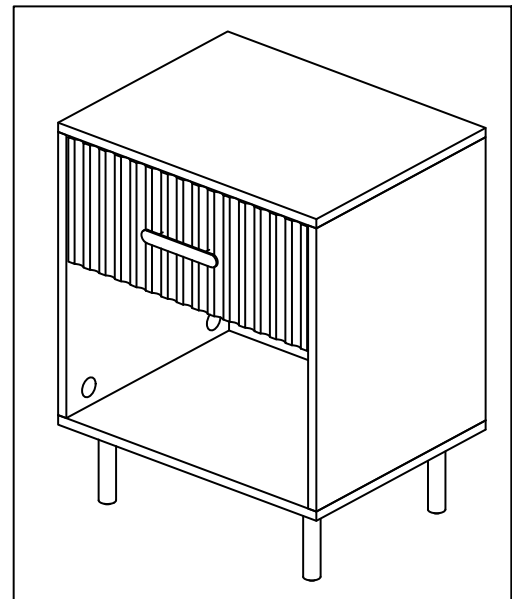
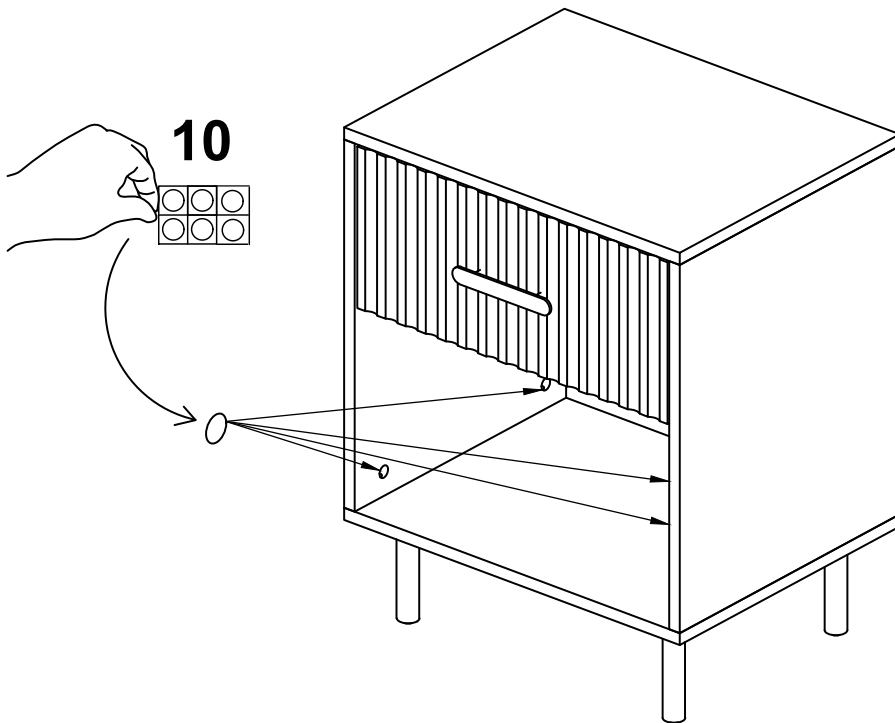

# Assembly | Asamblea | Assemblage

## May We Help You?

Please have this information ready when you call:

- Item Number
- PO #
- Purchaser Name
- Place of Purchase
- Purchase Date
- Date Product Arrived

## ¿Podemos ayudarle?

Tenga a mano esta información cuando llame:

- Número de artículo
- PO #
- Nombre del comprador
- Lugar de compra
- Fecha de compra
- Fecha en que llegó el producto

## Pouvons-nous vous aider?

Veuillez avoir cette information à portée de main lorsque vous appelez:

- Numéro d'article
- PO #
- Nom de l'acheteur
- Lieu d'achat
- Date d'achat
- Date d'arrivée du produit

Immediately examine this product carefully. Any request for missing or damaged part replacement must be received within 90 days of your receipt of the product. Requests for replacement parts, if available, will be honored within this time frame. Parts will not be available for items arriving fully assembled. We do not recommend modifying products and we are not responsible for any damages due to product modifications. If damages or missing parts are not reported within 90 days of receiving the product, we are under no obligation to provide parts or replacement merchandise. For product issues, please contact customer service. Please ask for a customer service representative for issues involving damages or replacement parts. Please ask for a technical assistance representative for any issues related to product assembly/construction. Regarding product returns, please contact the retailer from whom you purchased the product.

Please note, for items purchased in a retail store, you will need to contact the retailer for all part needs.

Products purchased at garage sales or discount stores are sold as-is and are not covered by the above warranty

Inmediatamente examine este producto con cuidado. Cualquier solicitud de reemplazo de piezas faltantes o dañadas debe recibirse dentro de los 90 días posteriores a la recepción del producto. Las solicitudes de repuestos, si están disponibles, serán atendidas dentro de este marco de tiempo. Las piezas no estarán disponibles para los artículos que lleguen completamente ensamblados. No recomendamos modificar los productos y no nos hacemos responsables de los daños debidos a las modificaciones del producto. Si no se informan daños o piezas faltantes dentro de los 90 días de haber recibido el producto, no estamos obligados a proporcionar piezas o productos de reemplazo. Para problemas con el producto, comuníquese con el servicio al cliente. Solicite a un representante de servicio al cliente si tiene problemas con daños o piezas de repuesto. Solicite un representante de asistencia técnica para cualquier problema relacionado con el montaje / construcción del producto. Con respecto a las devoluciones de productos, comuníquese con el vendedor al que le compró el producto.

Tenga en cuenta que, para los artículos comprados en una tienda minorista, deberá comunicarse con el minorista para todas las necesidades de piezas.

Los productos comprados en las ventas de garaje o tiendas de descuento se venden tal como están y no están cubiertos por la garantía anterior.

Immédiatement examiner ce produit soigneusement. Toute demande de remplacement de pièce manquante ou endommagée doit être reçue dans les 90 jours suivant la réception de votre produit. Les demandes de pièces de rechange, si elles sont disponibles, seront honorées dans ce délai. Les pièces ne seront pas disponibles pour les articles arrivant complètement assemblés. Nous ne recommandons pas de modifier les produits et nous ne sommes pas responsables des dommages causés par des modifications du produit. Si les dommages ou les pièces manquantes ne sont pas signalés dans les 90 jours suivant la réception du produit, nous ne sommes pas tenus de fournir des pièces ou des produits de remplacement. En cas de problème avec le produit, veuillez contacter le service clientèle. S'il vous plaît demander à un représentant du service clientèle pour les problèmes impliquant des dommages ou des pièces de rechange. Veuillez demander à un représentant de l'assistance technique de résoudre tout problème lié à l'assemblage / la construction du produit. En ce qui concerne les retours de produits, veuillez contacter le détaillant chez qui vous avez acheté le produit.

Veuillez noter que pour les articles achetés dans un magasin de détail, vous devrez contacter le détaillant pour tous les besoins en pièces.

Les produits achetés dans les vide-greniers ou les magasins à prix réduits sont vendus tels quels et ne sont pas couverts par la garantie ci-dessus.