

Assembly Instruction

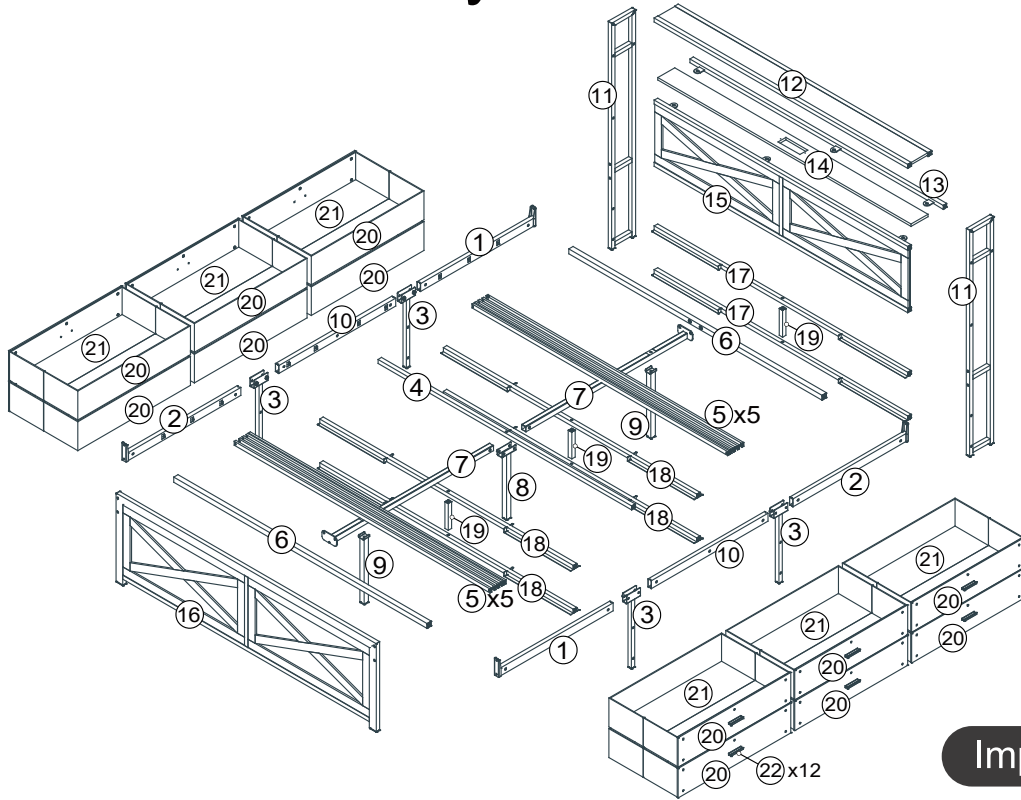

Important Note

NOTE: This set of products is divided into two boxes of packaging, please open all cartons and find the corresponding accessories for installation.

HARDWARE NOTE :

1. Two or more people are required for assembly
2. Do not screw on the bolts too tight unless the installation is done. Make sure all bolts are tightly screwed before you use it.

Components

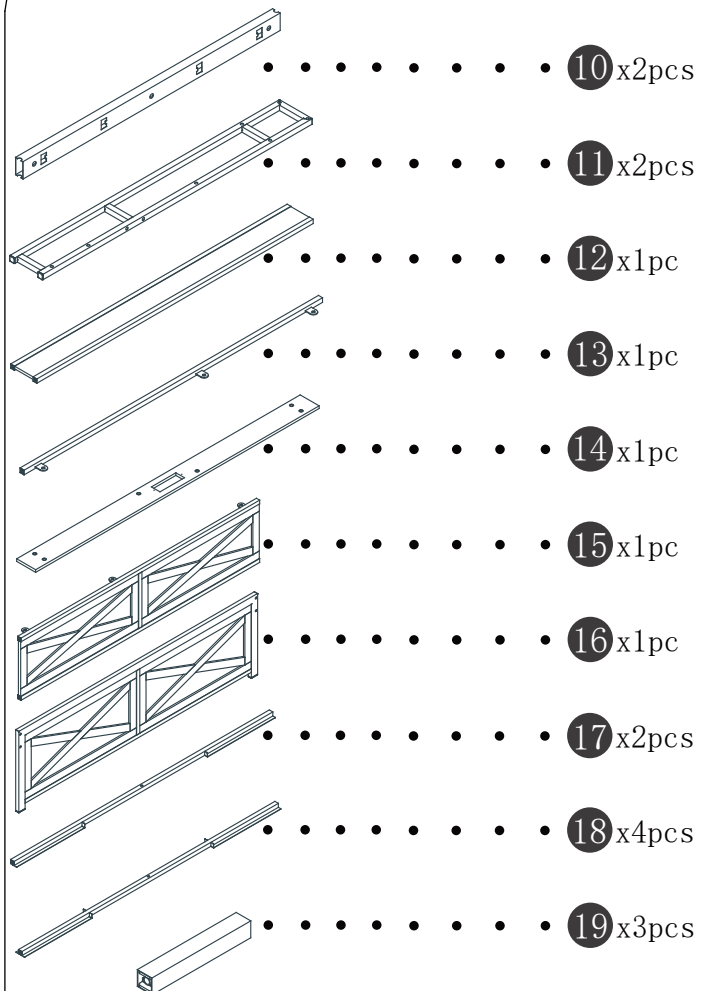
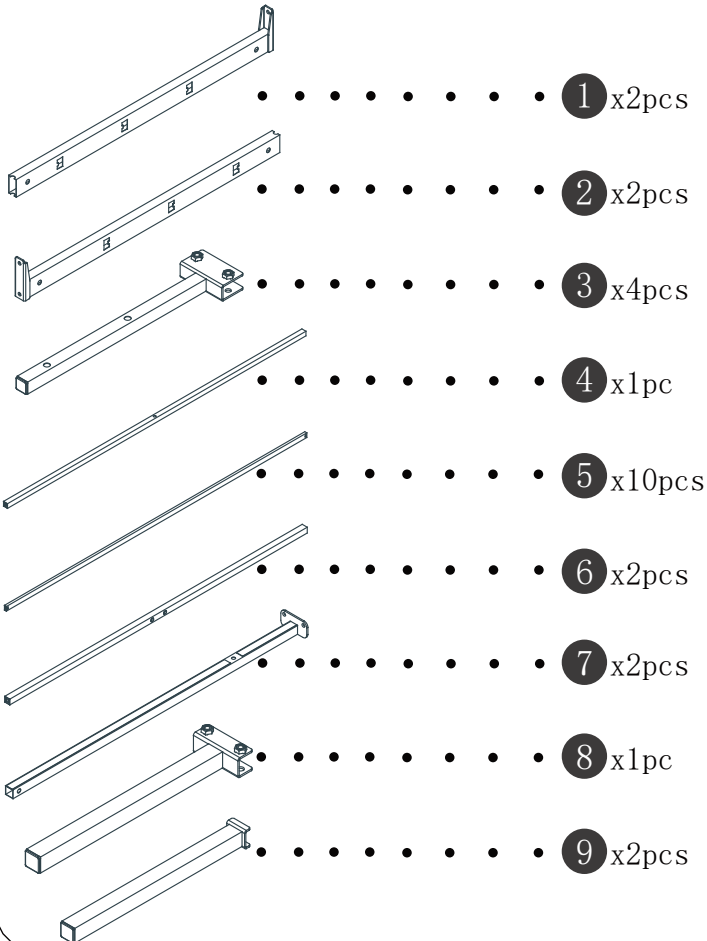

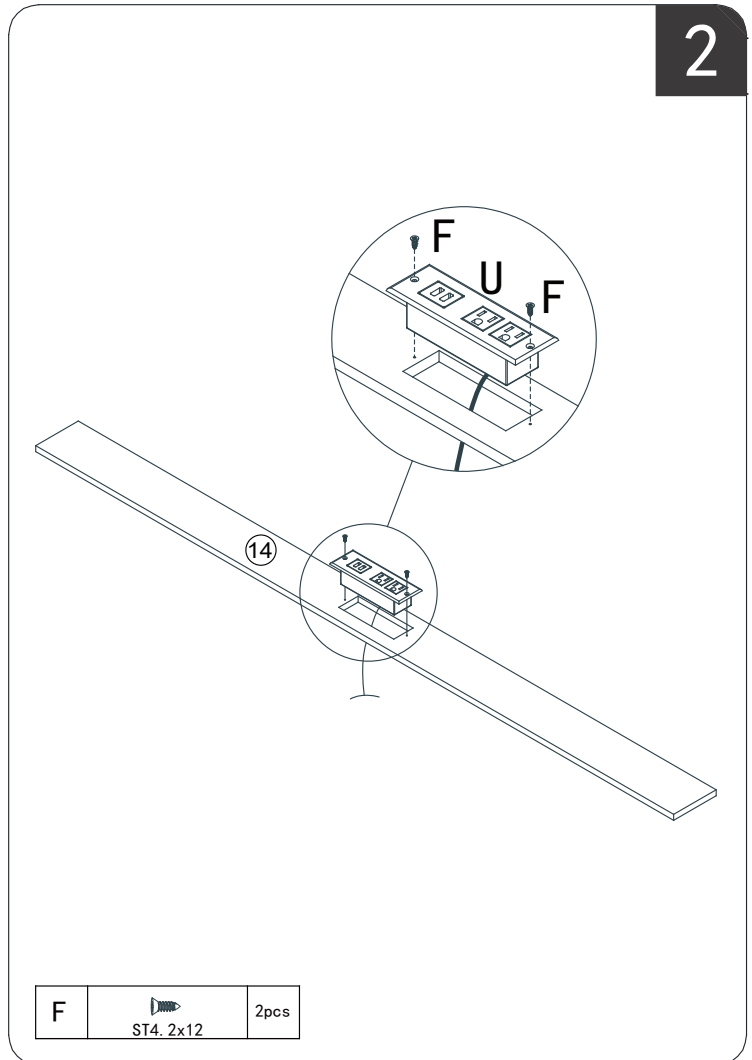
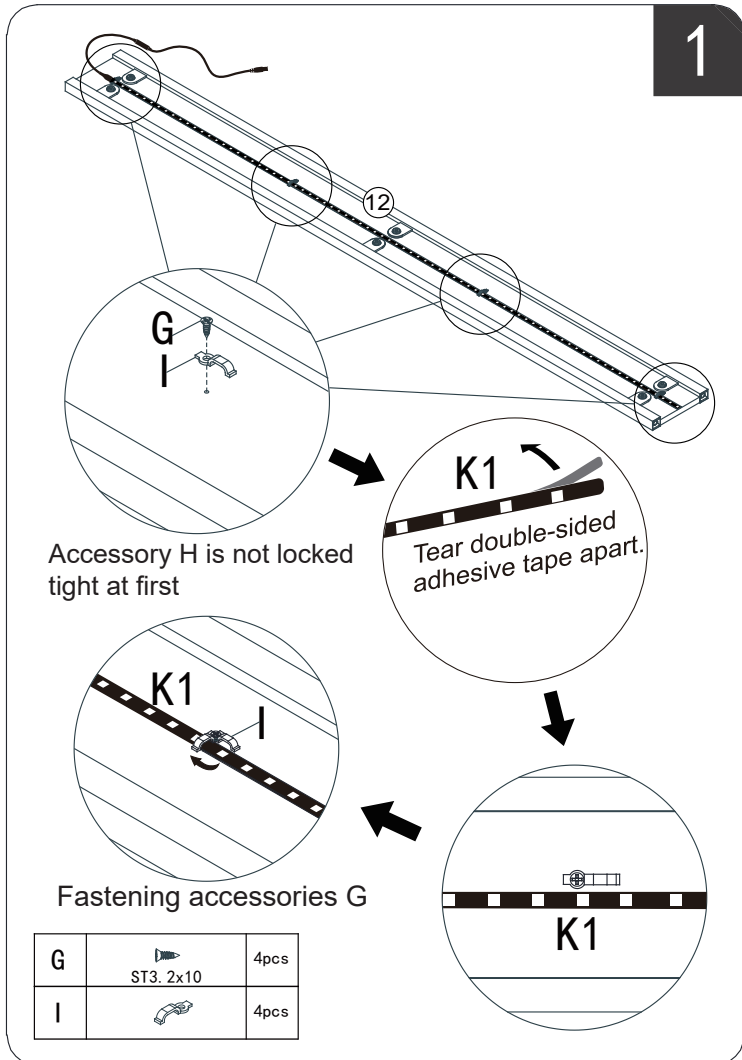
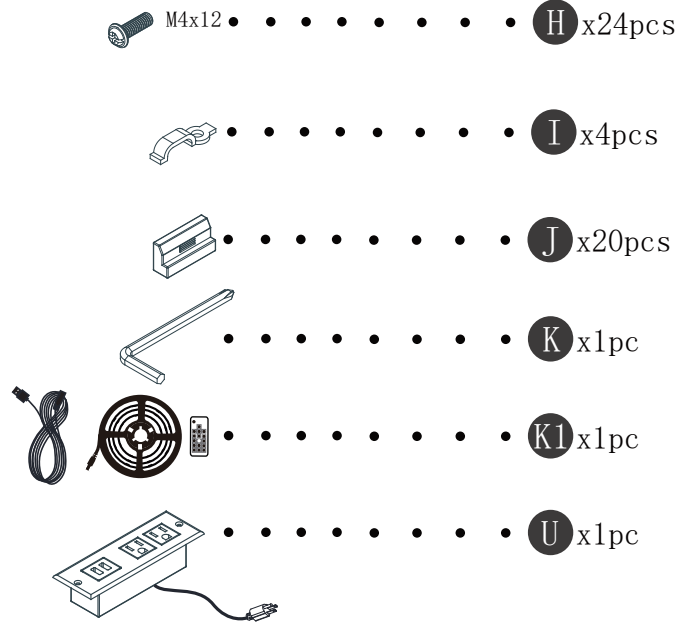
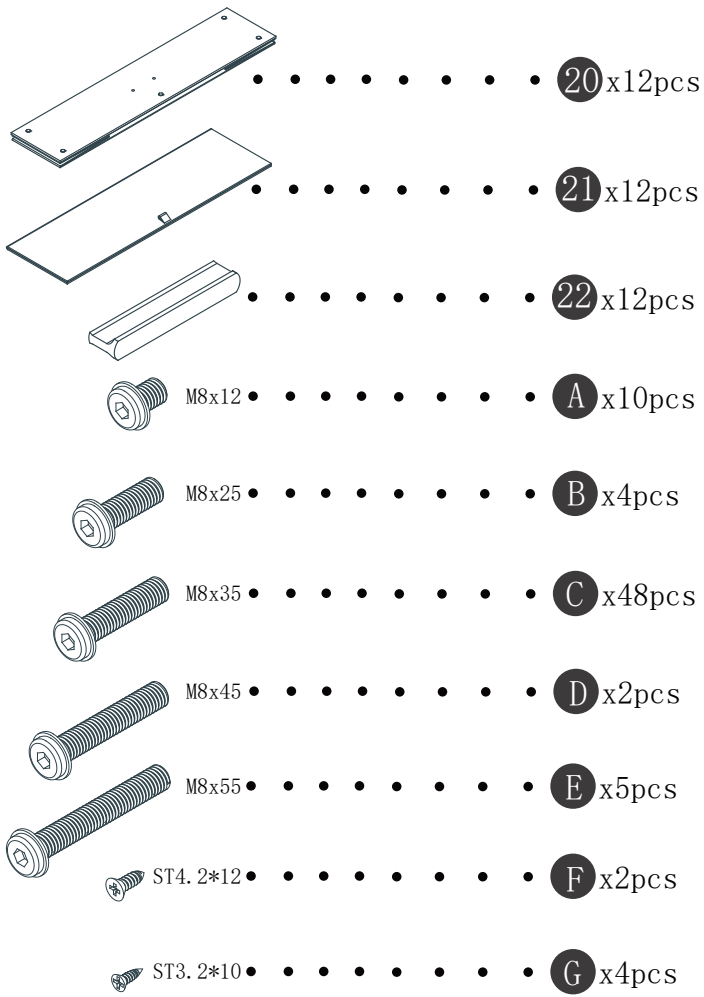

3

weld marks facing up

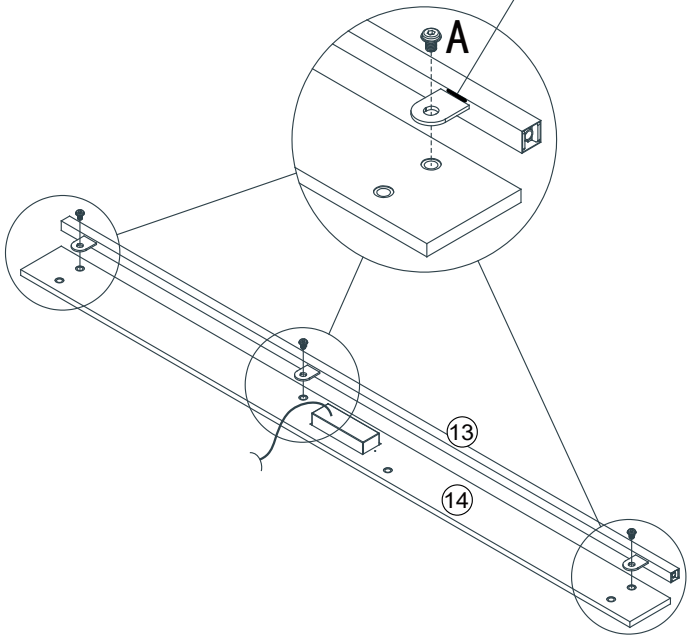

A		3pcs
M8x12		

4

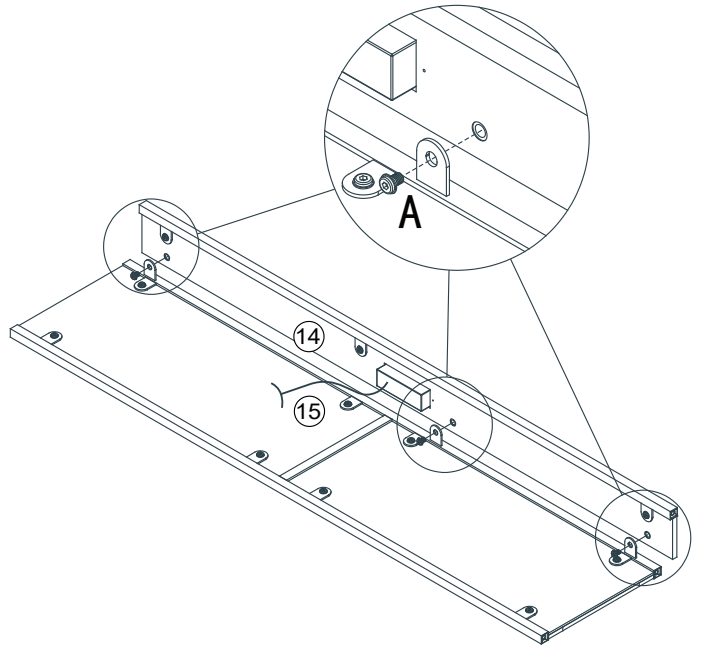

A		3pcs
M8x12		

5

 Do not fully tighten the screws yet.

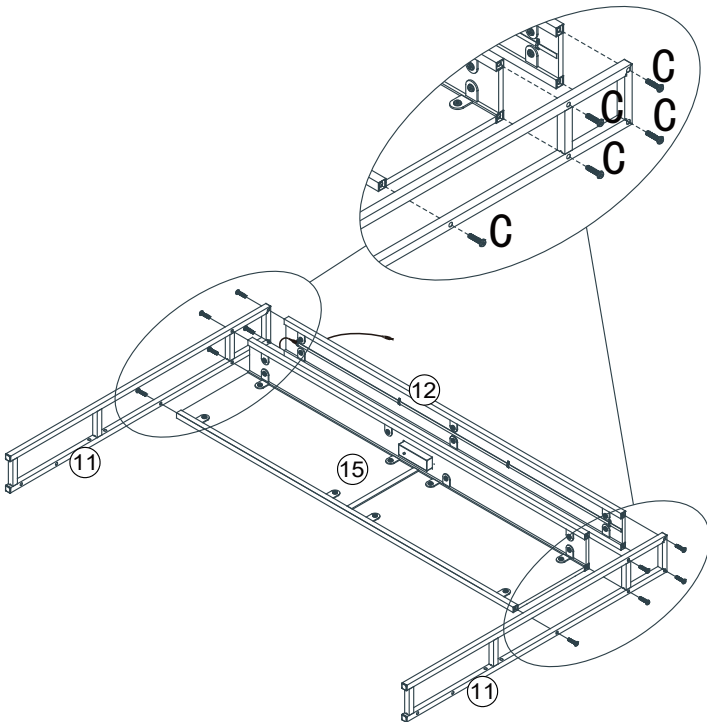

C		10pcs
M8x35		

6

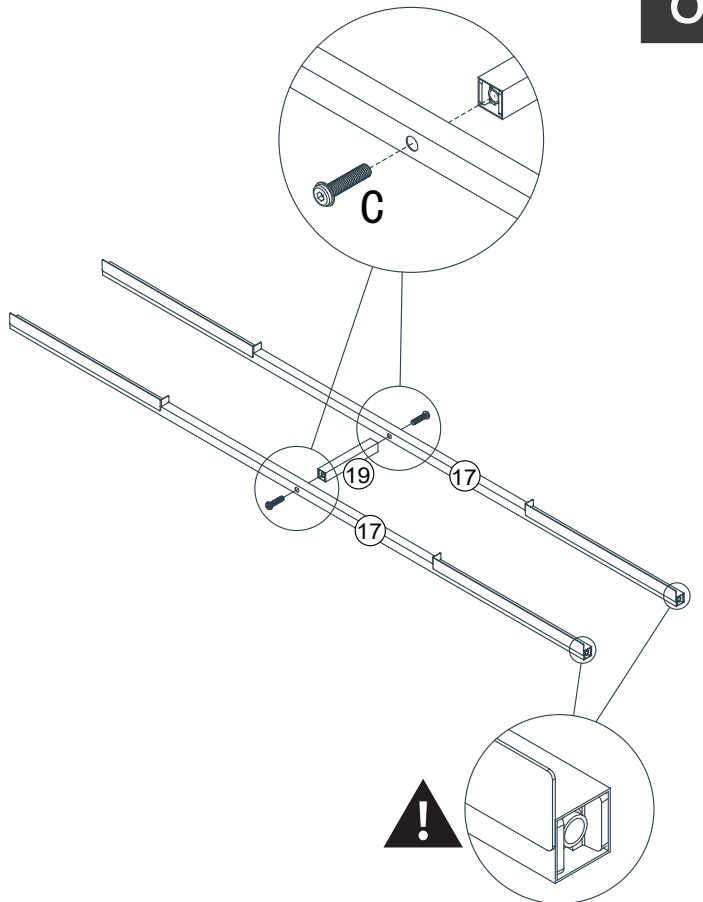

C		2pcs
M8x35		

7

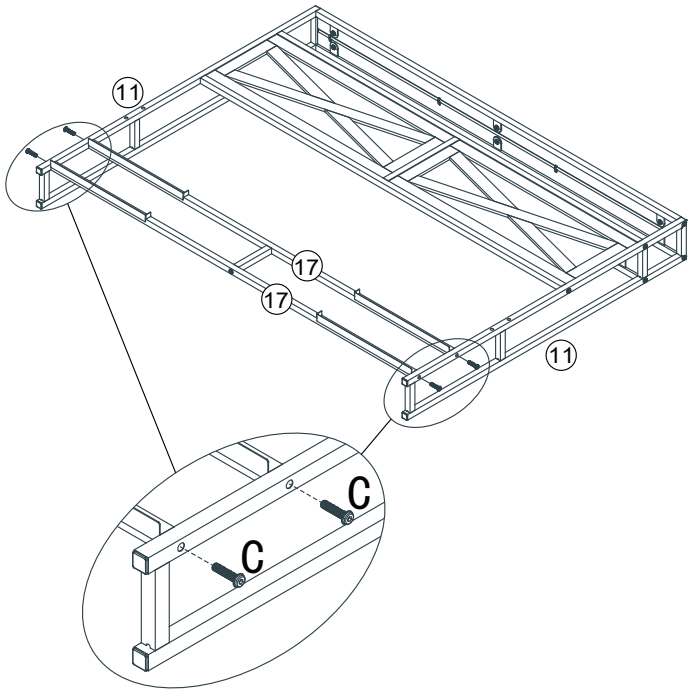



! Fully tighten all the screws.

C		4pcs
	M8x35	

8

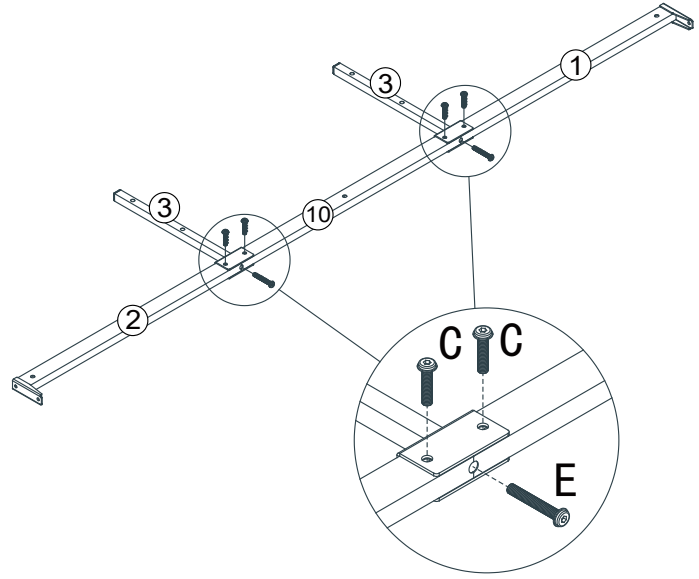

x2



C		8pcs
	M8x35	
E		4pcs
	M8x55	

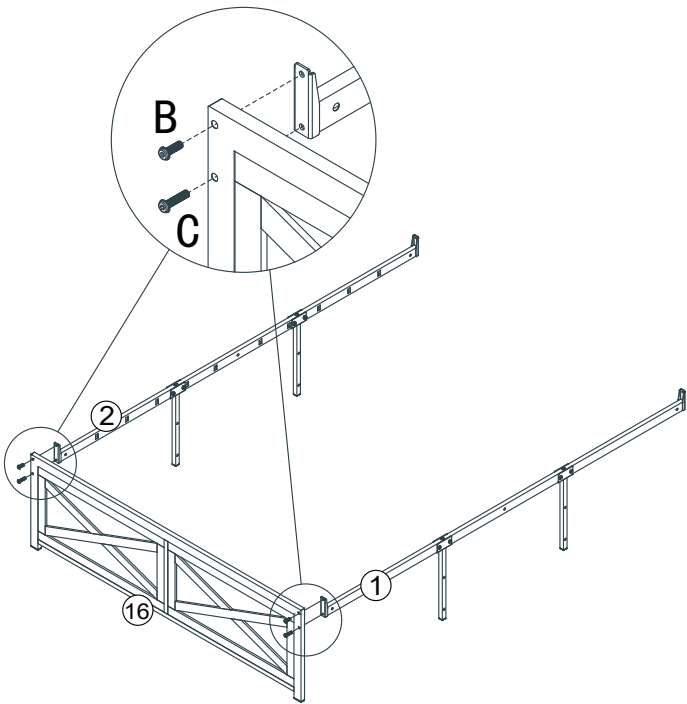

9

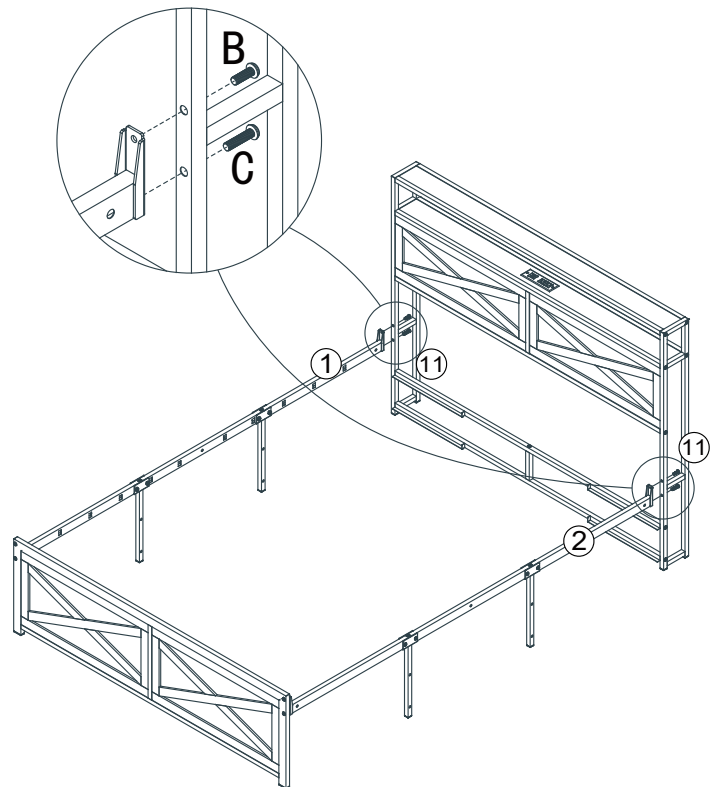

B		2pcs
	M8x25	
C		2pcs
	M8x35	

10



B		2pcs
	M8x25	
C		2pcs
	M8x35	

11

x2

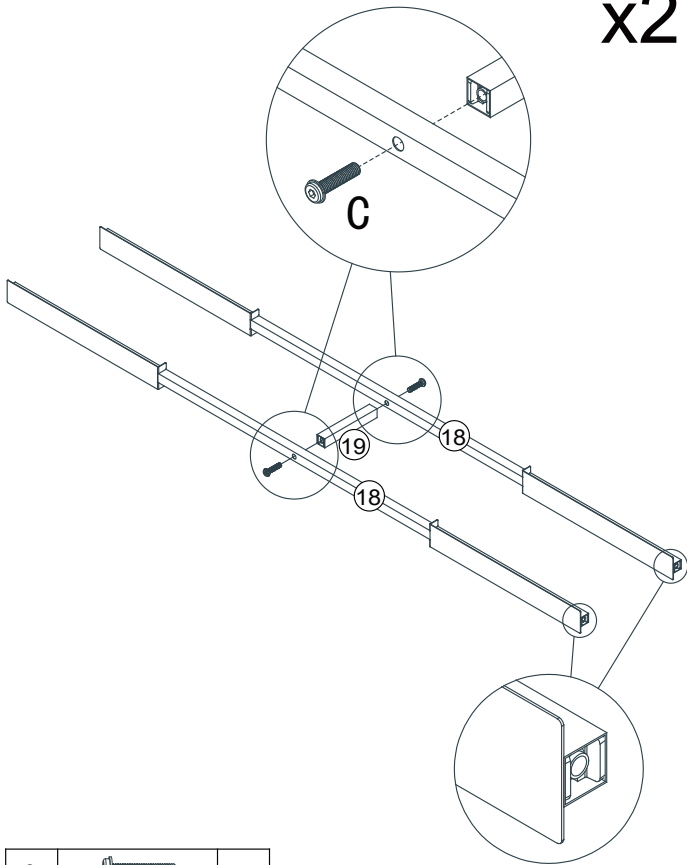

C		4pcs
M8x35		

12

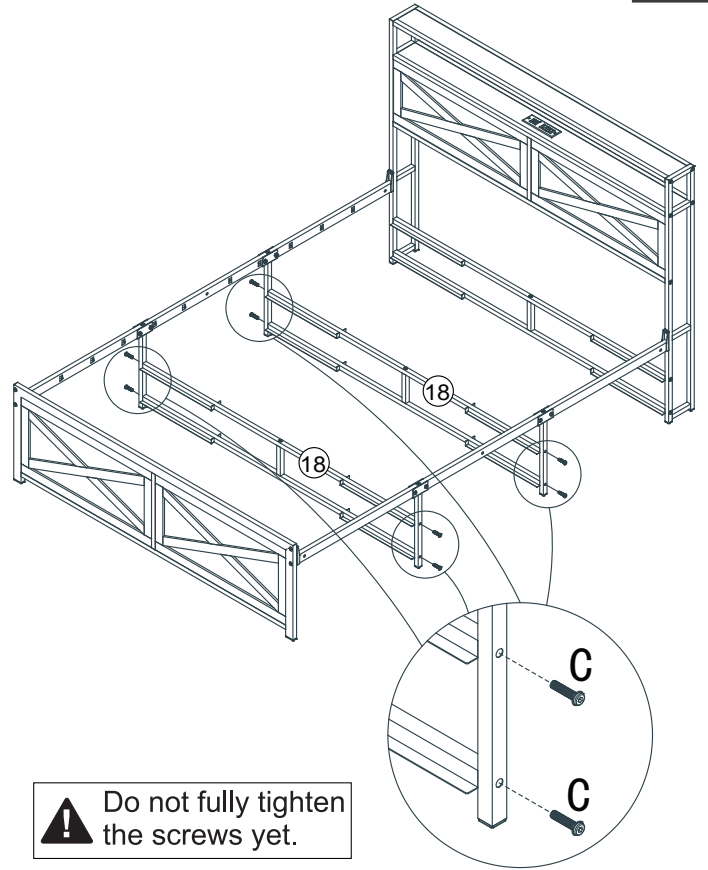



 Do not fully tighten the screws yet.

C		8pcs
M8x35		

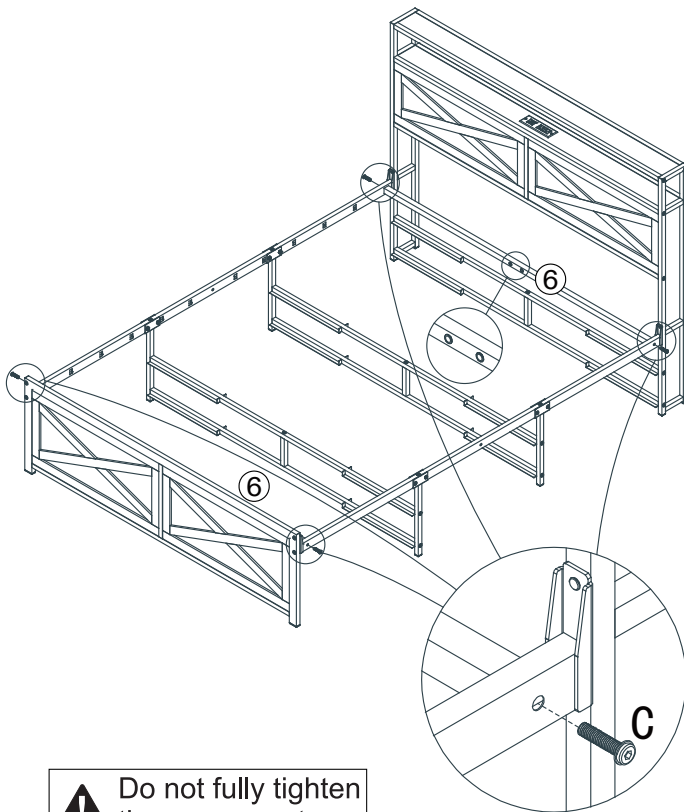
13





 Do not fully tighten the screws yet.

C		4pcs
M8x35		

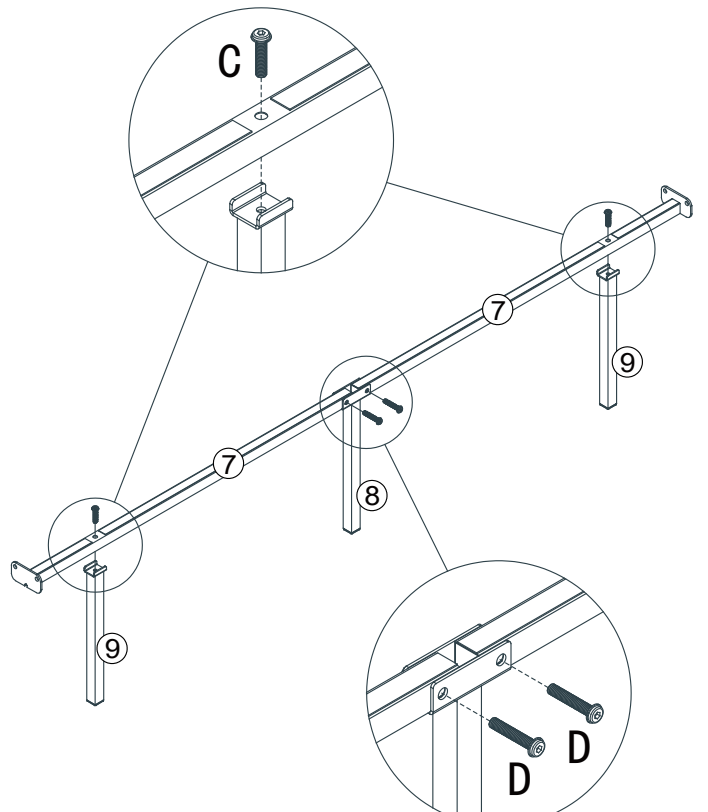
14



 Do not fully tighten the screws yet.

C		2pcs
M8x35		
D		2pcs
M8x45		

15

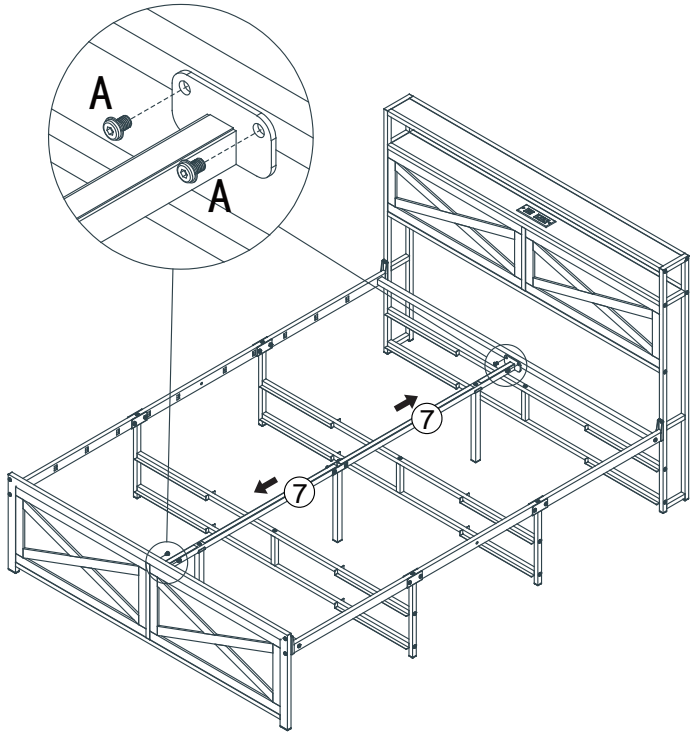

A		4pcs
---	---	------

16

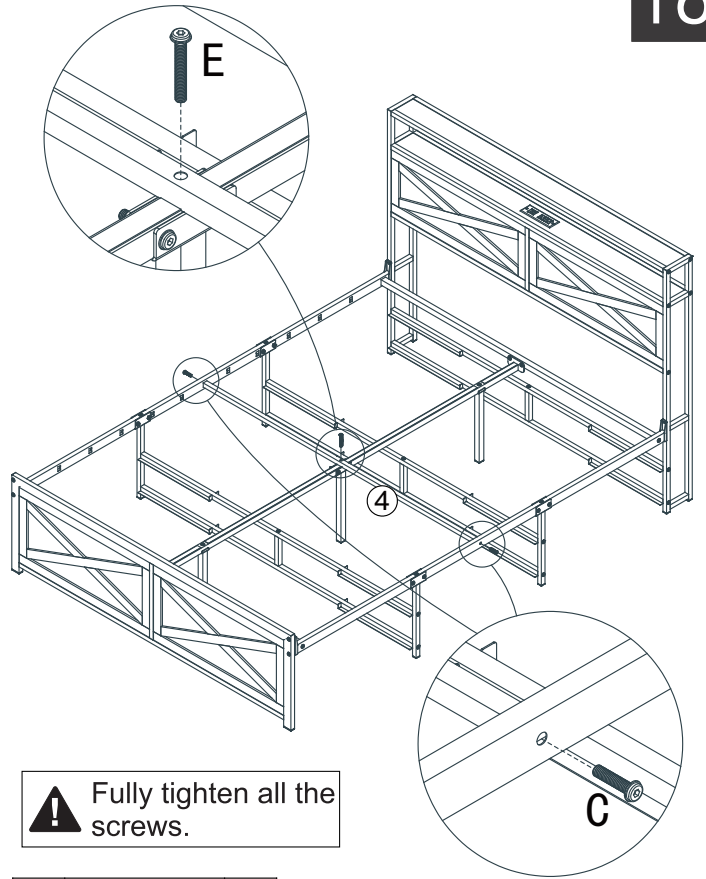

! Fully tighten all the screws.

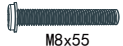
C		2pcs
E		1pc

17

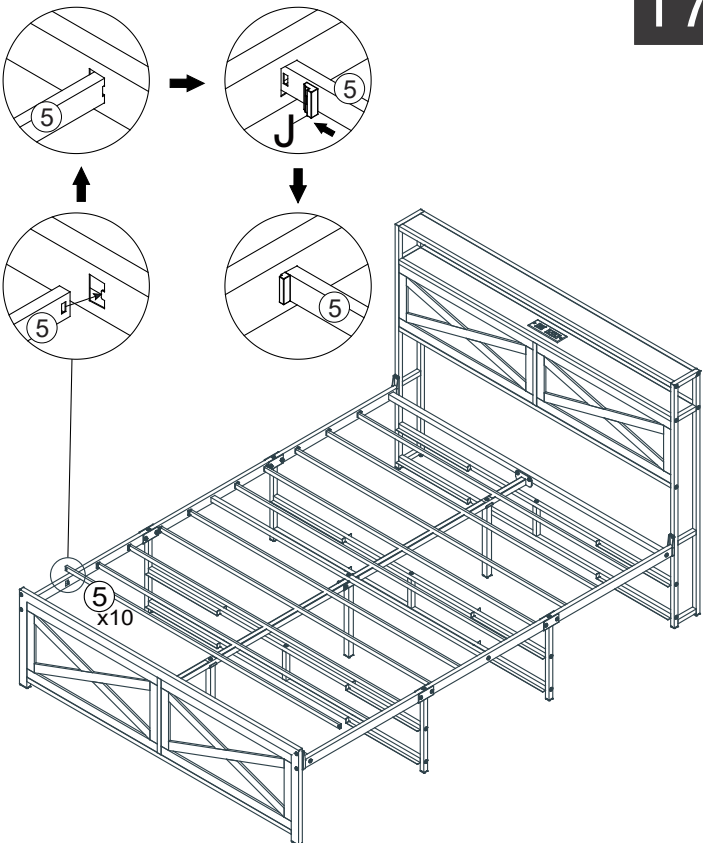

J		20pcs
---	---	-------

x12 18

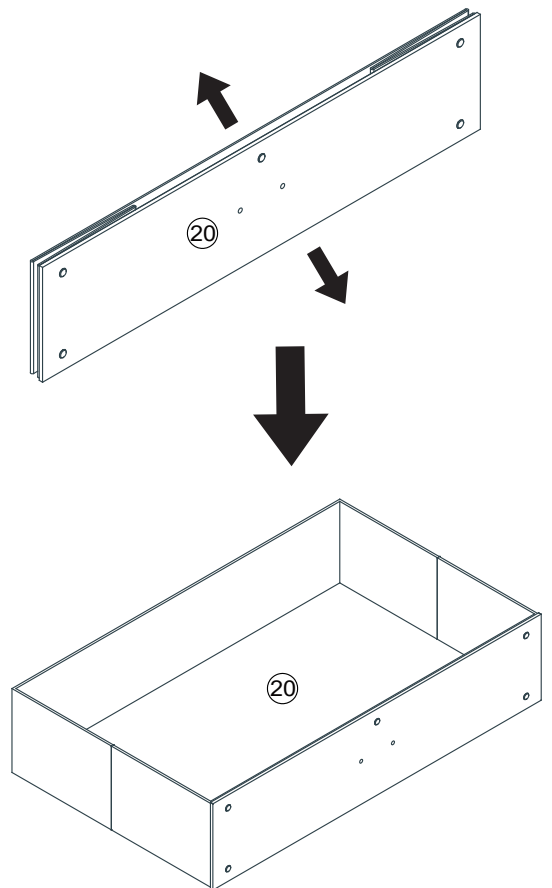

x12 19

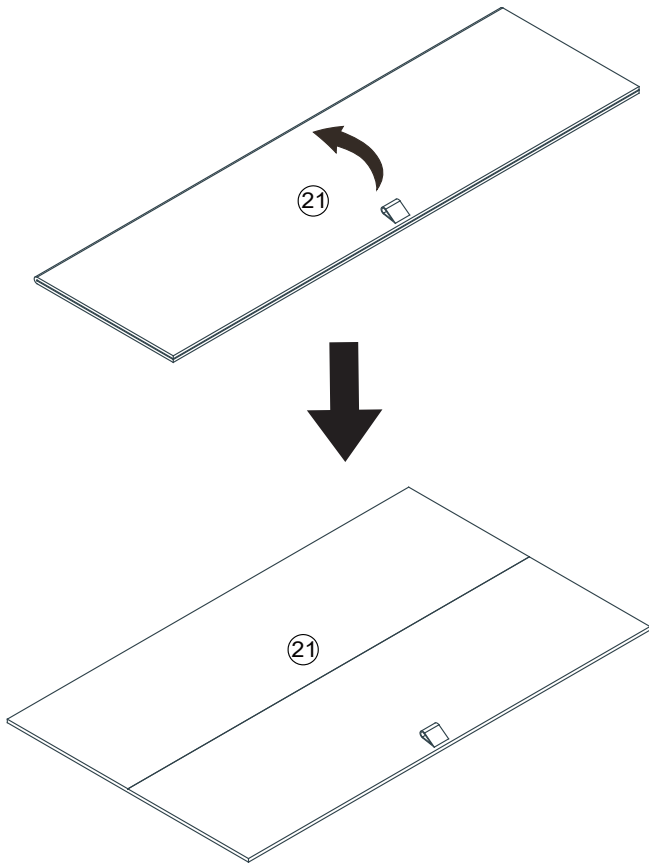

x12 20

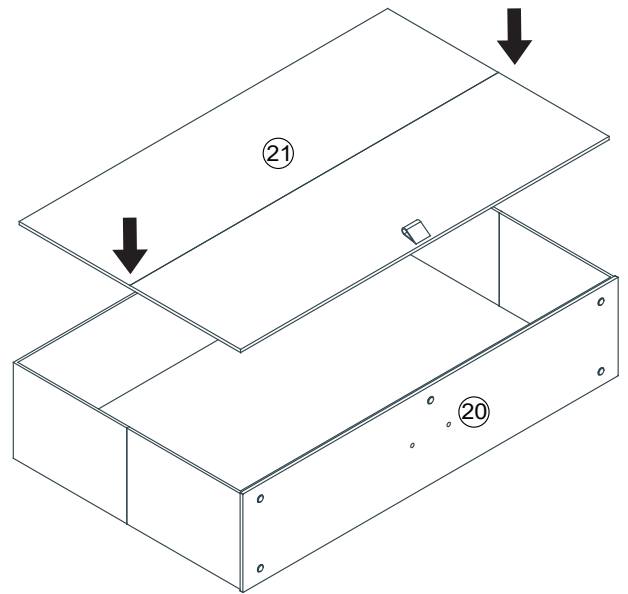

x12 21

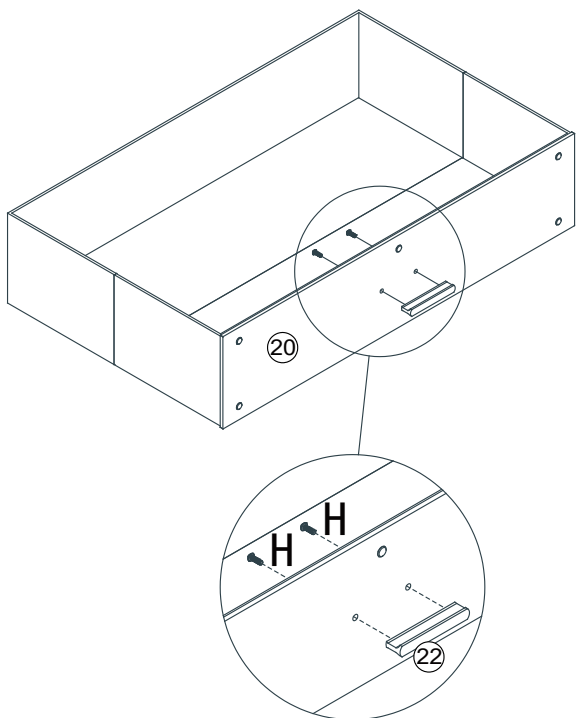

22

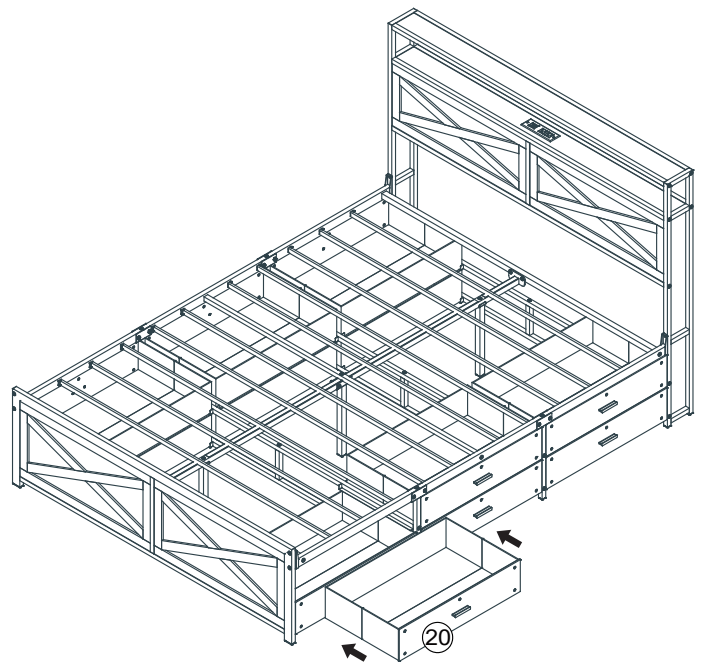

H		24pcs
M4x12		

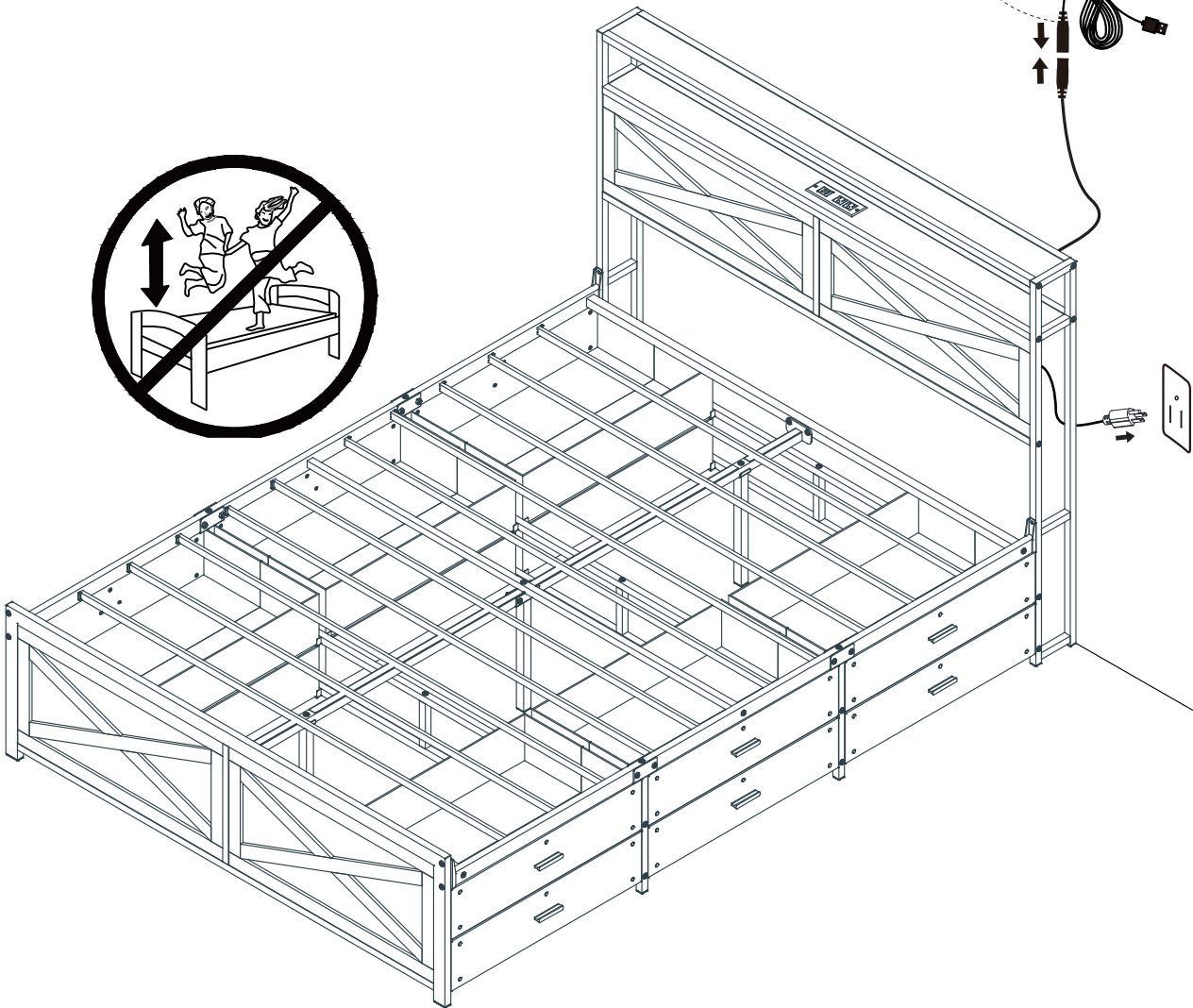
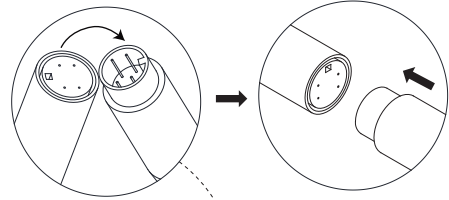

Finish