

Assembling Instruction

Generating Drawings

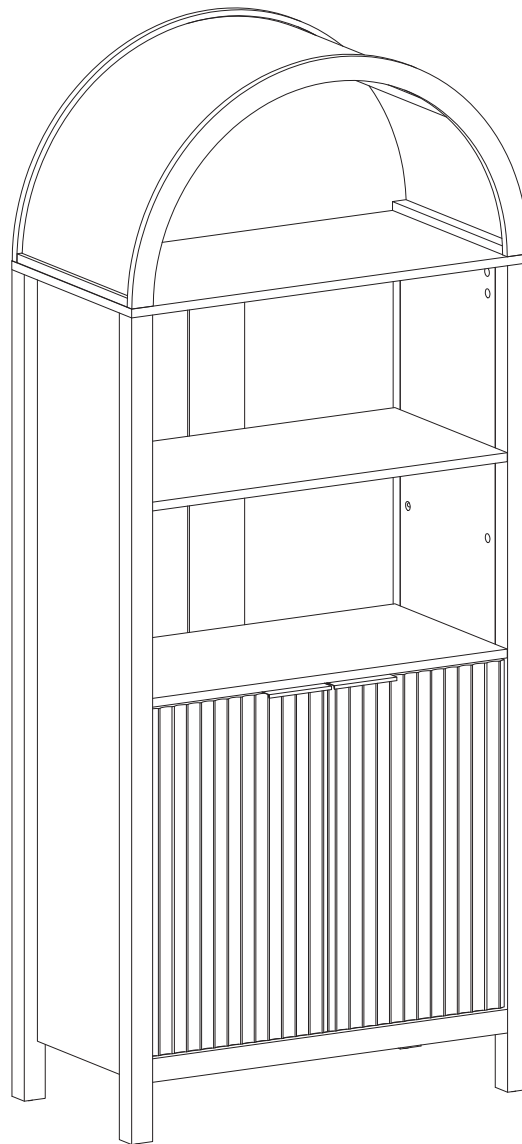

ATTENTION

If there is any missing, please kindly send us messages to let us know the name of missing part regarding to the first page of instructions.

Please also provide us your full address so we can send replacement to you as soon as possible

We are concerned about each customer's experience, if there is any loss or damage, please contact us at any time, we will provide effective solutions.

Customer service,

Please attach your Order ID so that we can assist you better



General Assembly Guidelines

- I. Ensure that all parts and hardware are available before beginning assembly.
- II. Follow each step carefully to ensure the proper assembly of this product.
- III. Two people are recommended for ease in the assembly of this product.
- IV. The three main types of hardware used to assemble this product are : wood dowels , screws and bolts.
- VI . A Phillips head screwdriver is required for the assembly of this product .

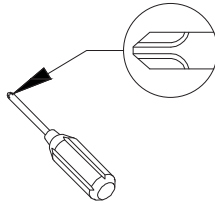

- VII . Power tools should not be used to assemble this product .

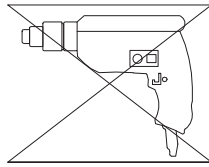

CAM LOCK/BOLT FASTENING INTRODUCTION (You will use it during assembly)

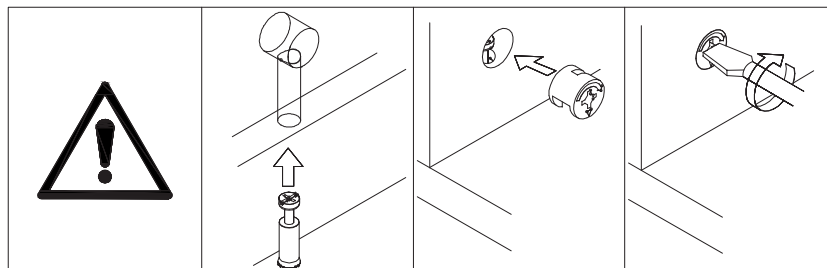
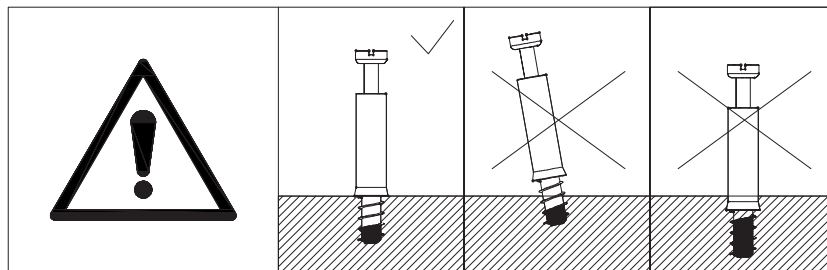

Parts List

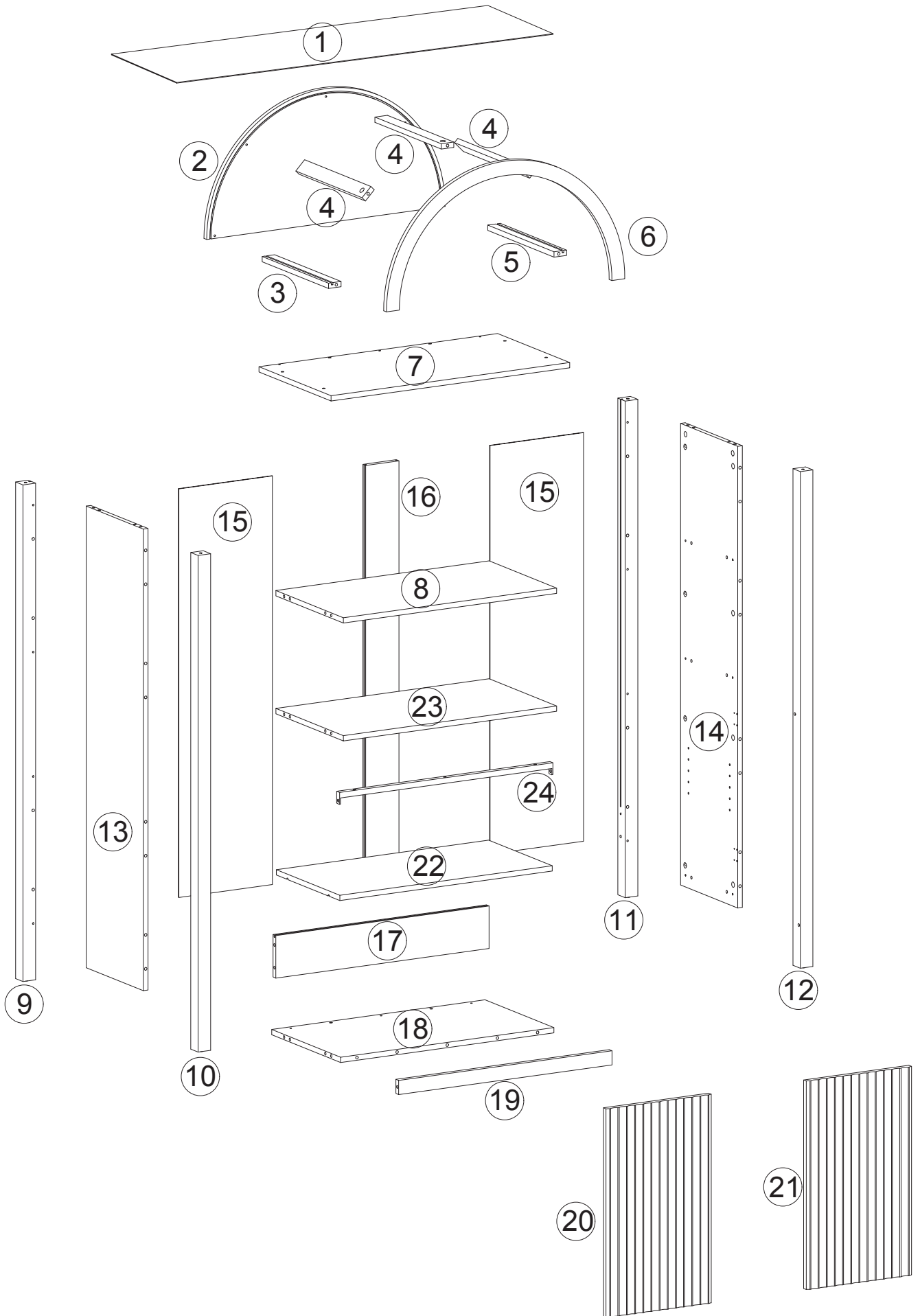

HARDWARE PACK CONTENT

A



Ø6*33.5mm

48X+3

B



Ø15*1.1mm

48X+3

C



Ø8*30mm

46X+3

D

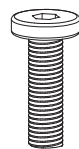

M6*22mm

4X

E

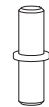

Ø5*18mm

4X+1

F

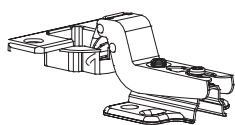

4X

G

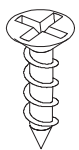

Ø4*14mm

24X+2

H

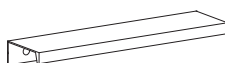

2X

I



Ø3.5*12mm

4X+1

J

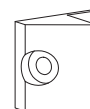

16X+2

K

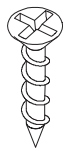

Ø3*16mm

16X+2

L

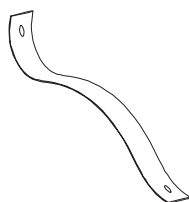

2X

M



Ø8*40mm

2X

N



Ø4*14mm

2X

O



Ø4*38mm

2X

P

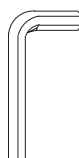

4mm

1X

Q

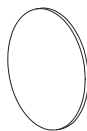

Ø30mm

20X+2

R

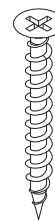

Ø4*30mm

5X

S

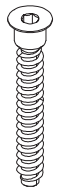

Ø6*48mm

20X+2

T



M6*12mm

2X

U

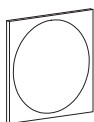

2X

V

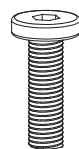

M6*27mm

3X

Step 1

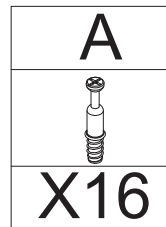

9

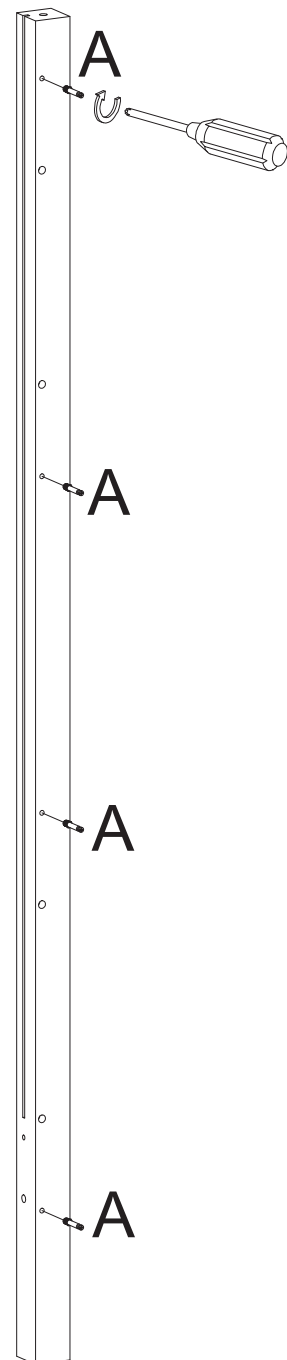

11

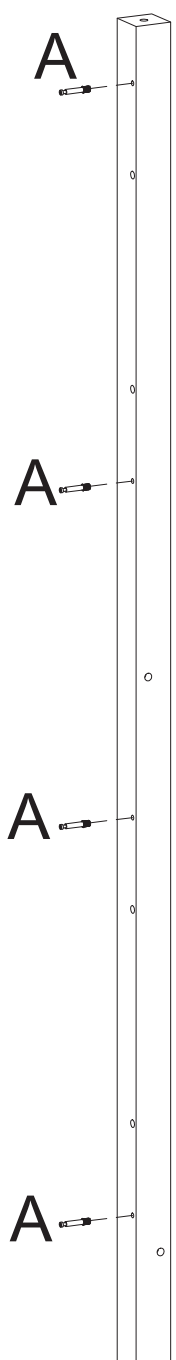

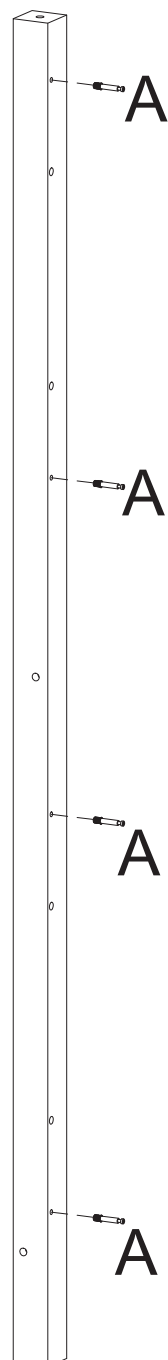

12





10

Step 2

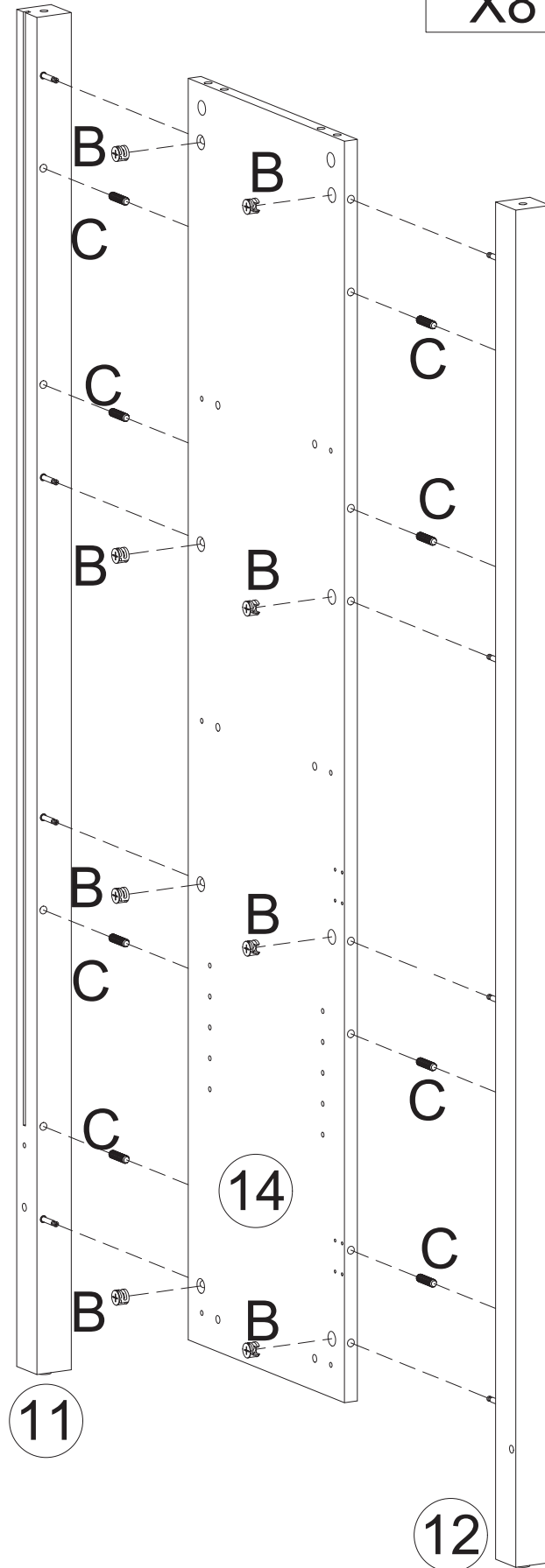
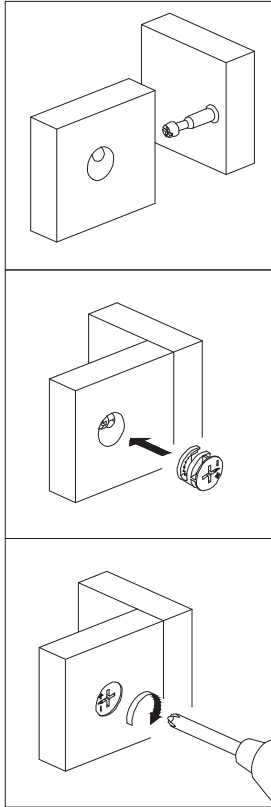
B	C
	
X8	X8



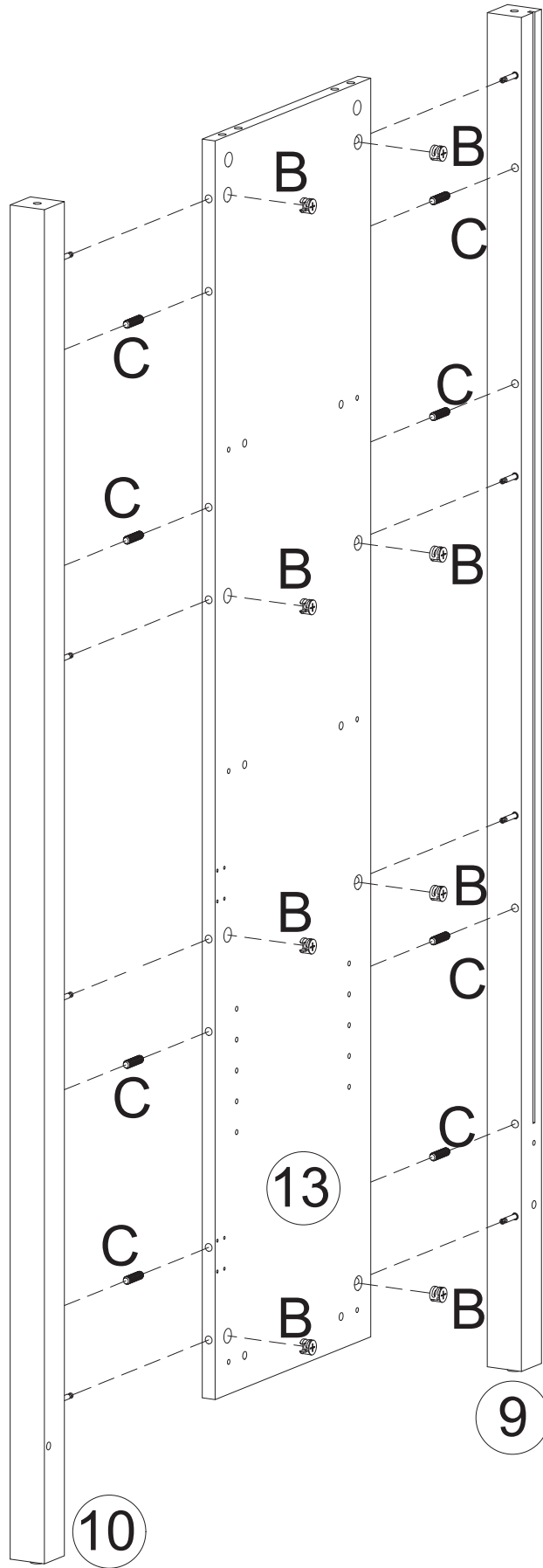

Step 3

B	C
	
X8	X8



Step 5

A	B	C
		
X6	X3	X2



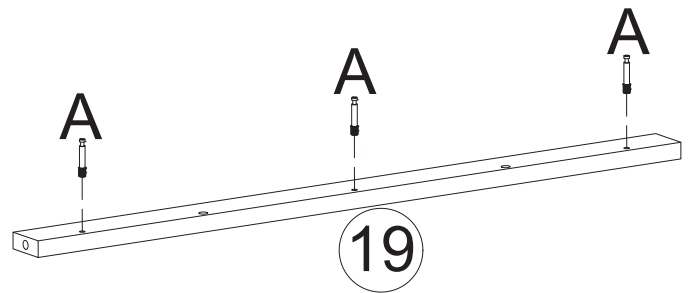
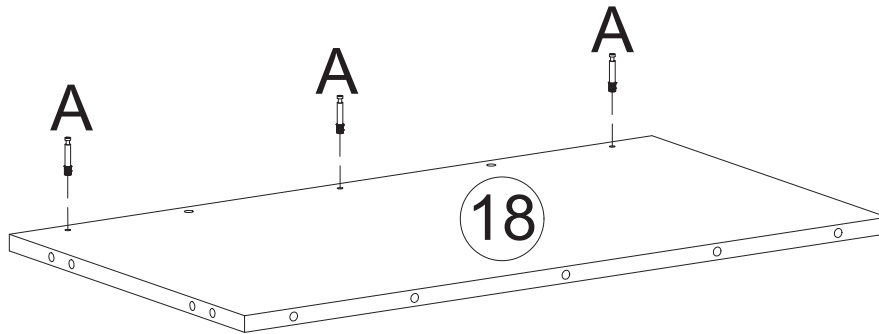

Step 5-1

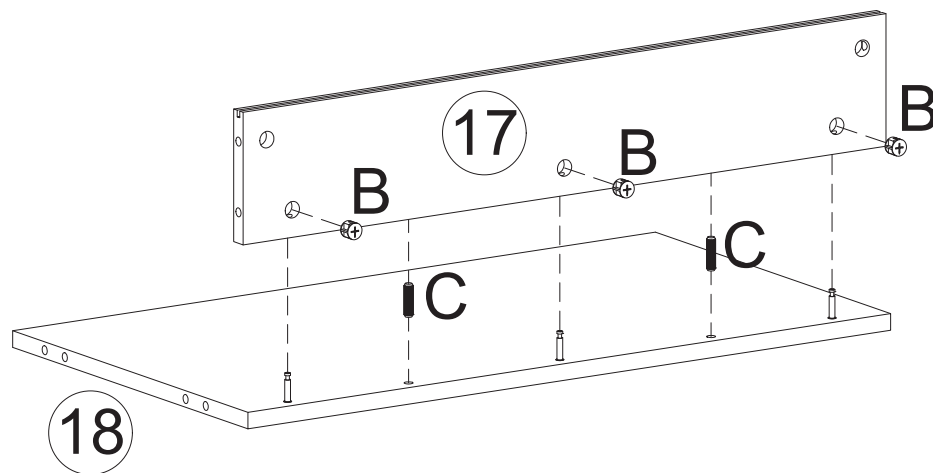

Step 5-2



Step 6

B	C	V	P
			
X3	X2	X3	X1

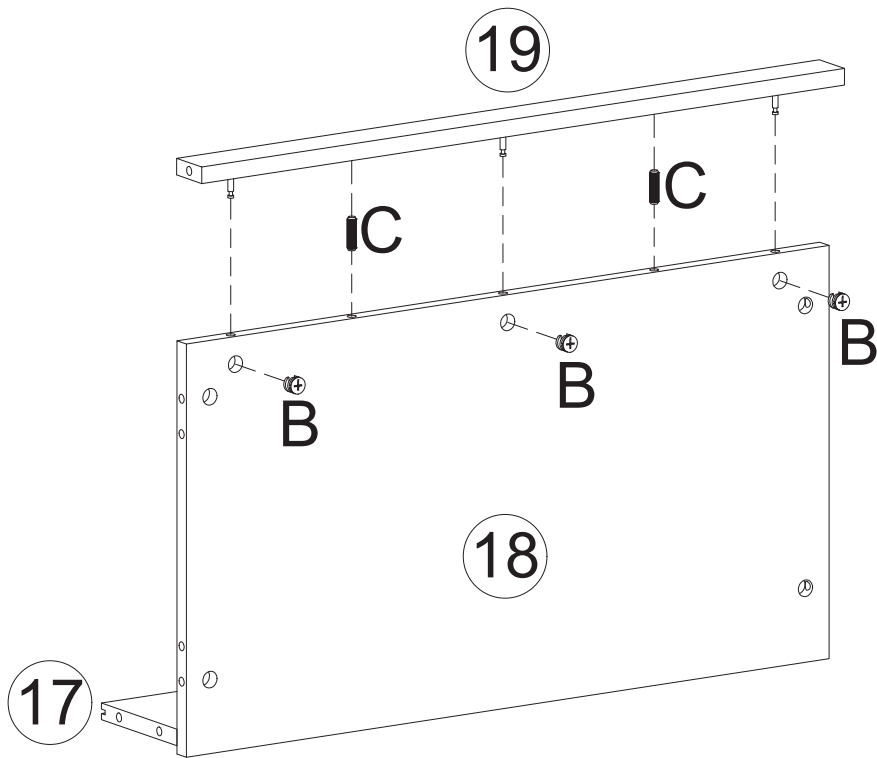

Step 6-1

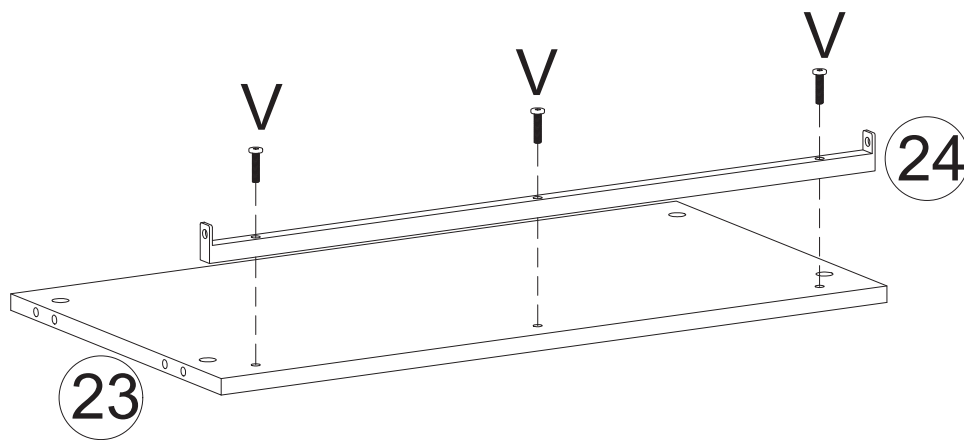

Step 6-2



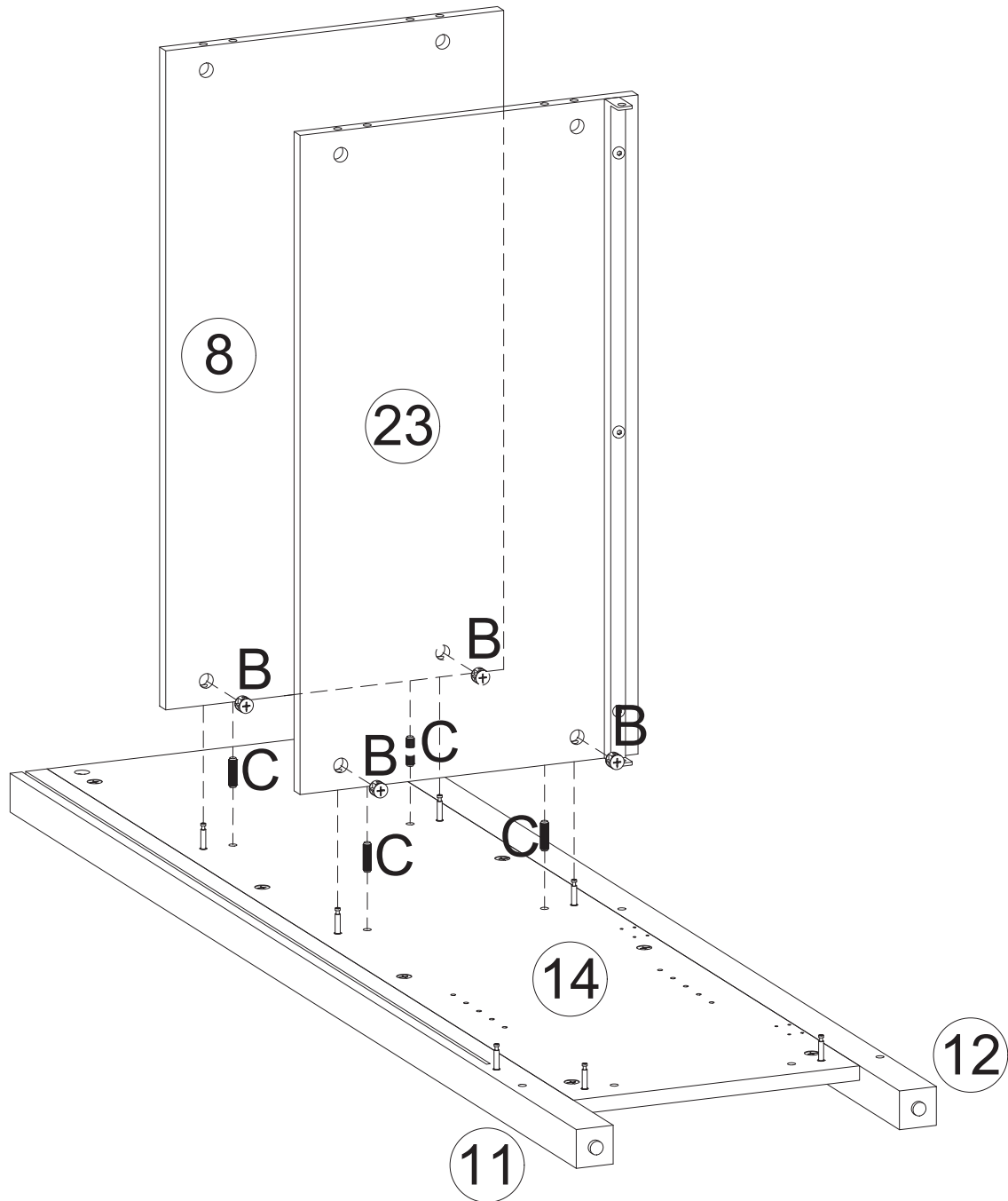

Step 7

B	C
	
X4	X4



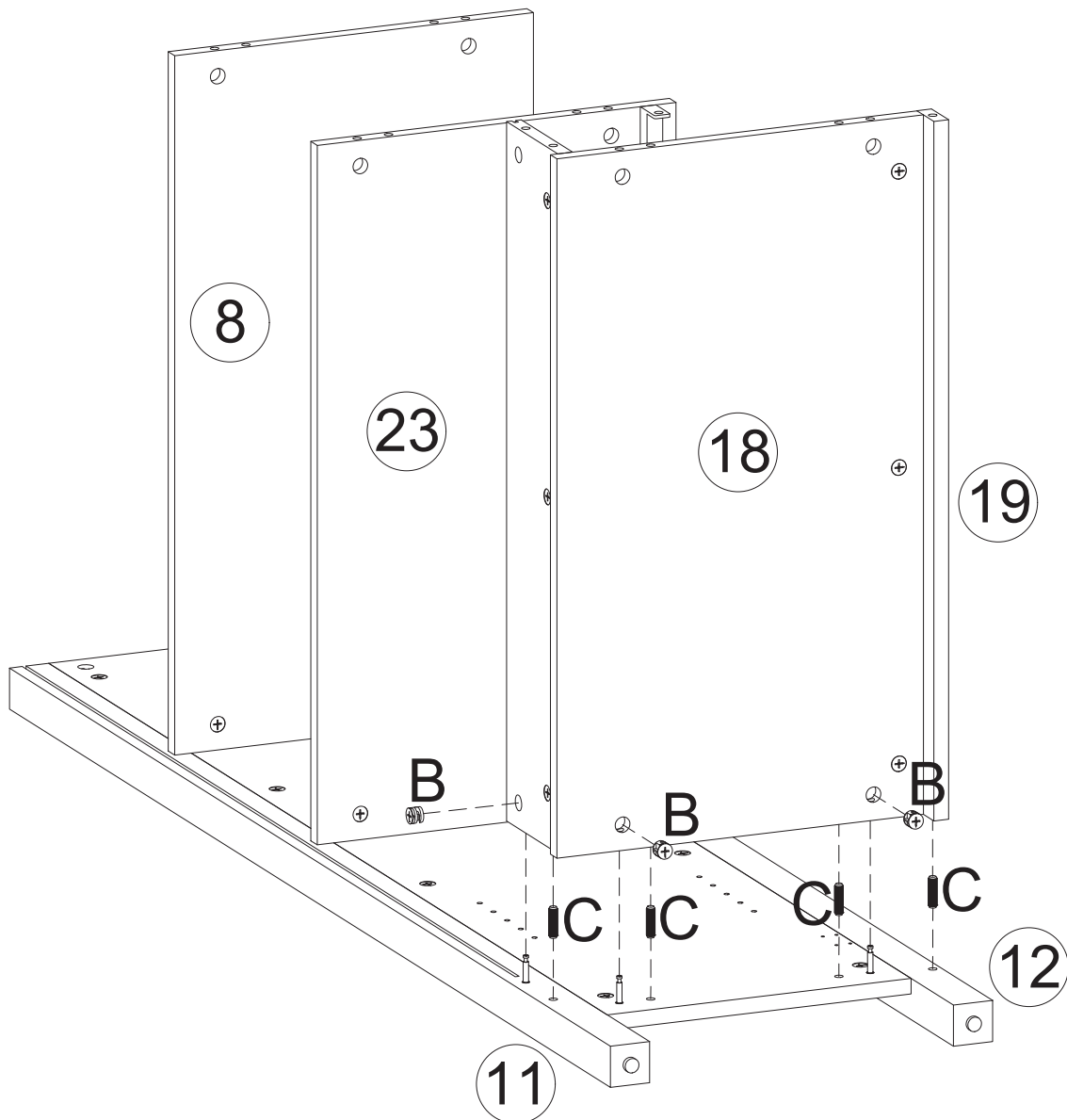

Step 8

B	C
	
X3	X4



Step 9

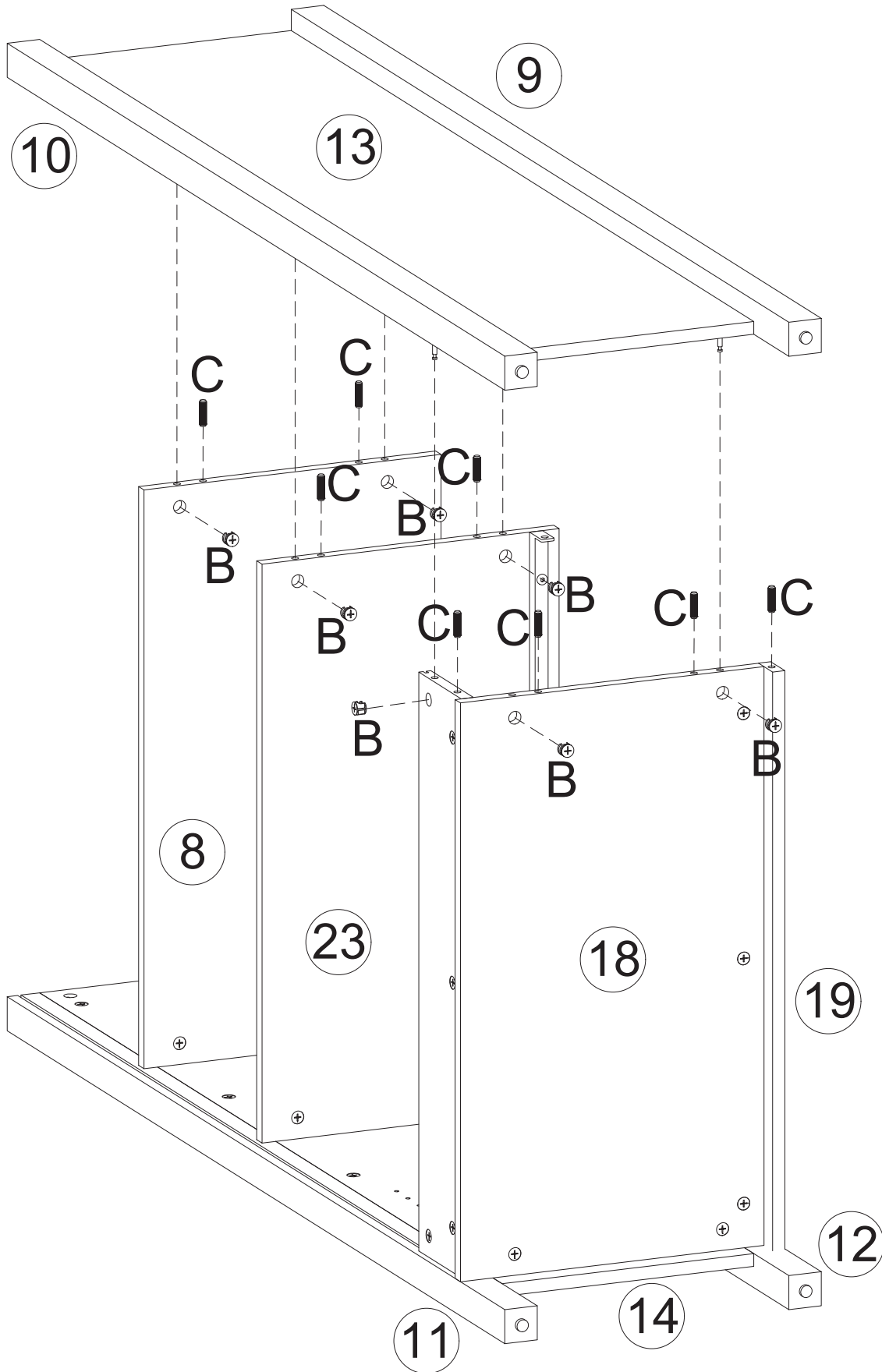

B	C
	
X7	X8



Step 10



Step 11

A	B
	
X5	X4

Step 11-1

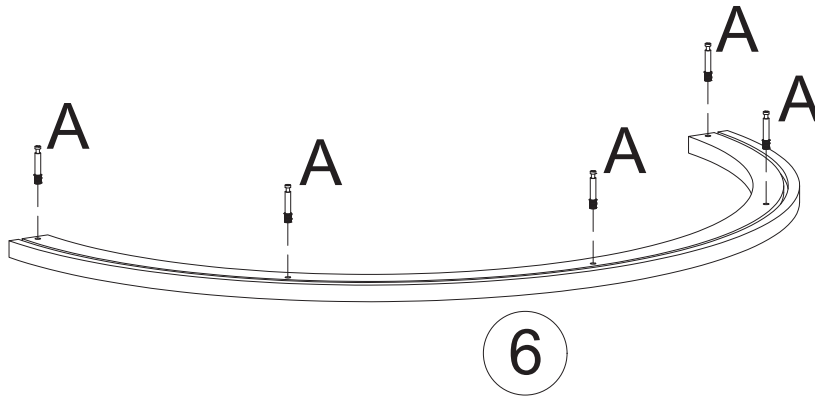

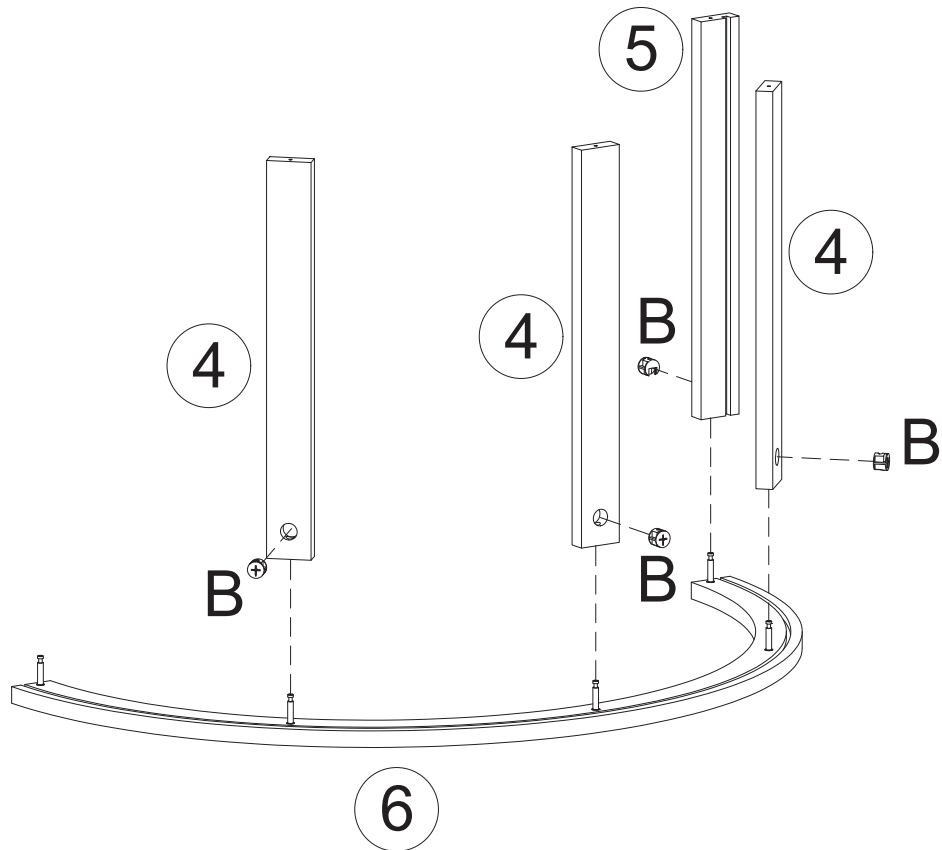

Step 11-2

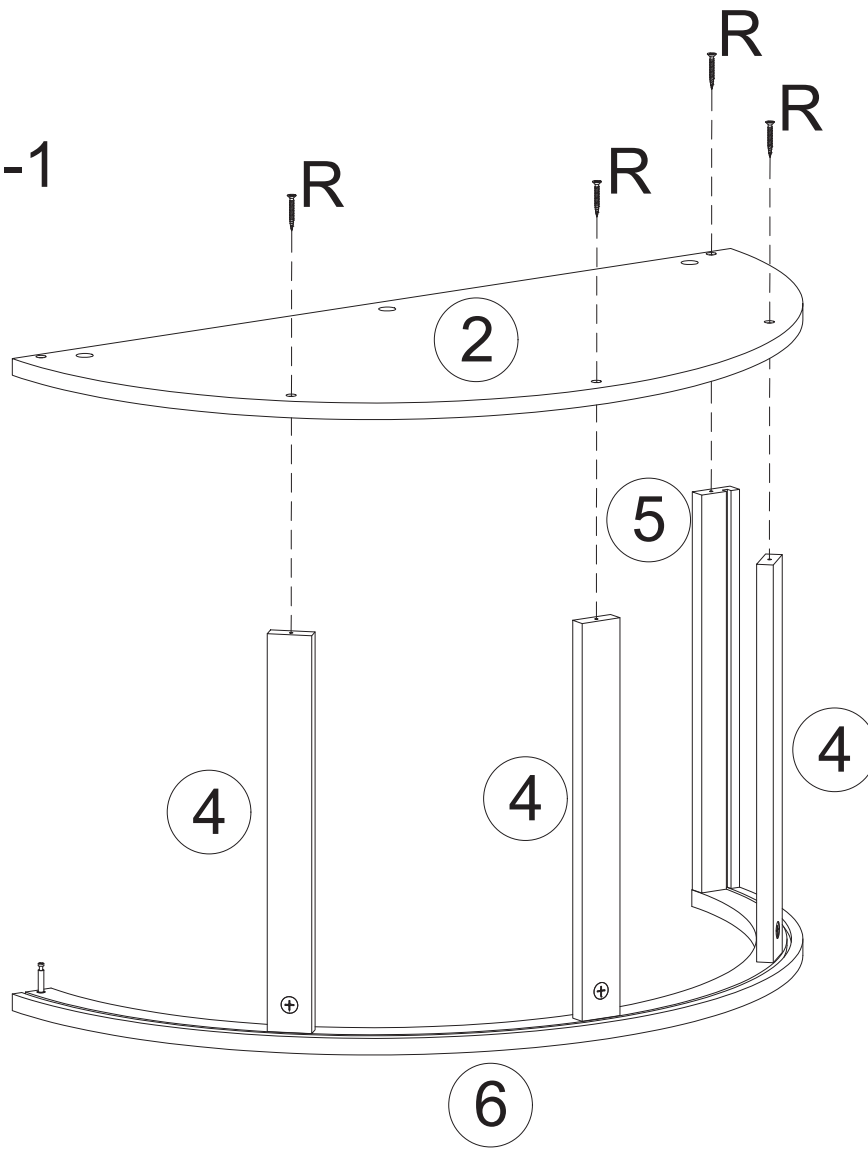

Step 12

Step 12-1



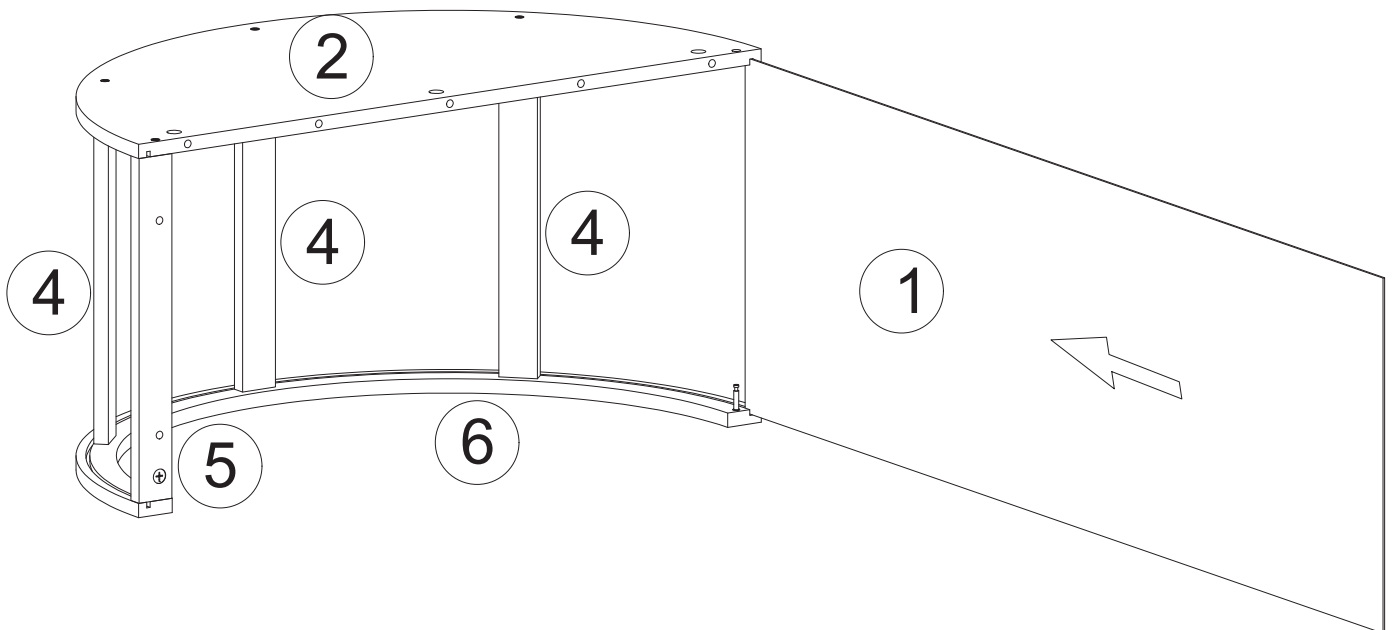

R

X4

Step 12-2



Step 13

B	R
	
X1	X1

Step 13-1

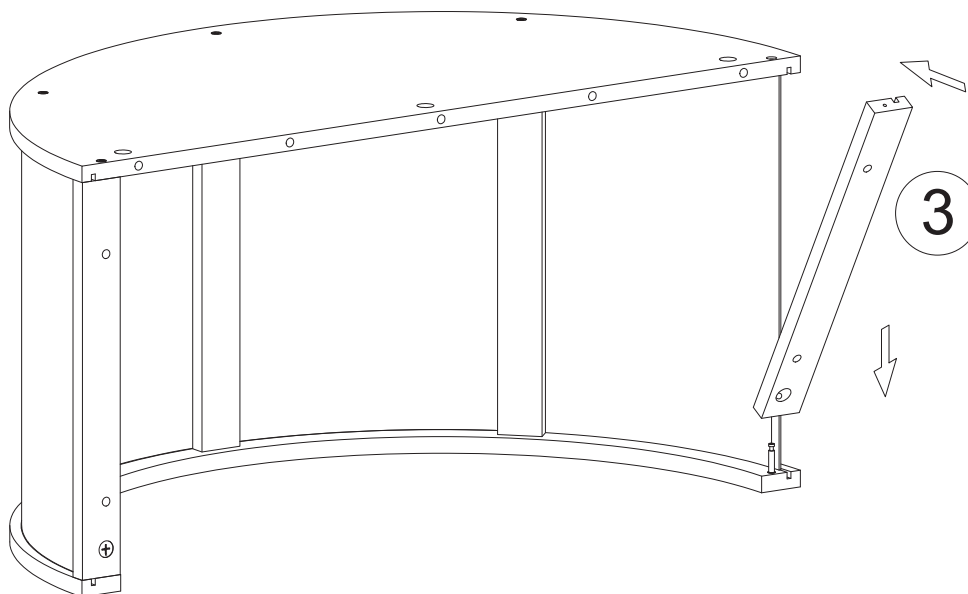

Step 13-2

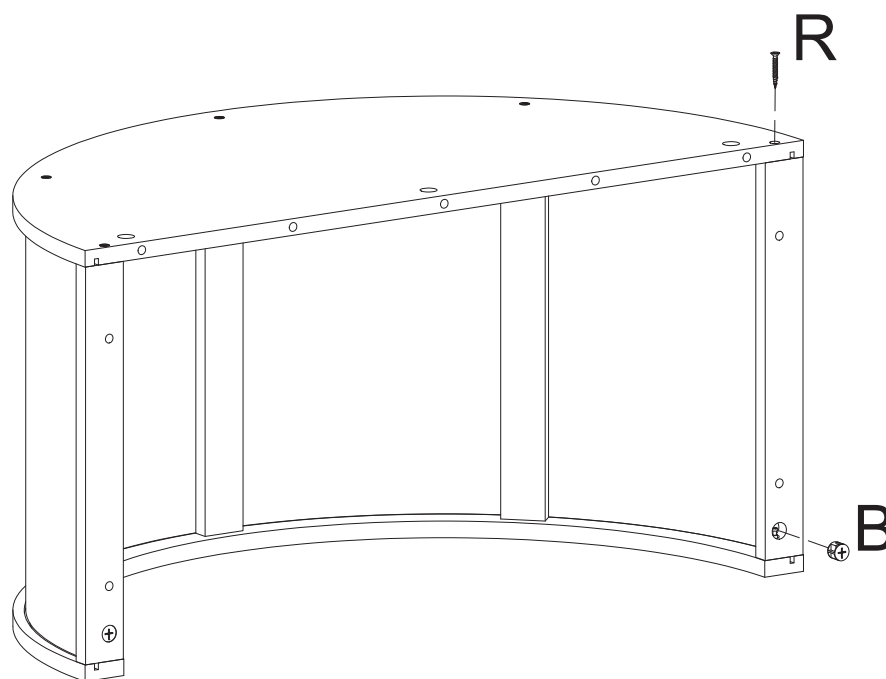



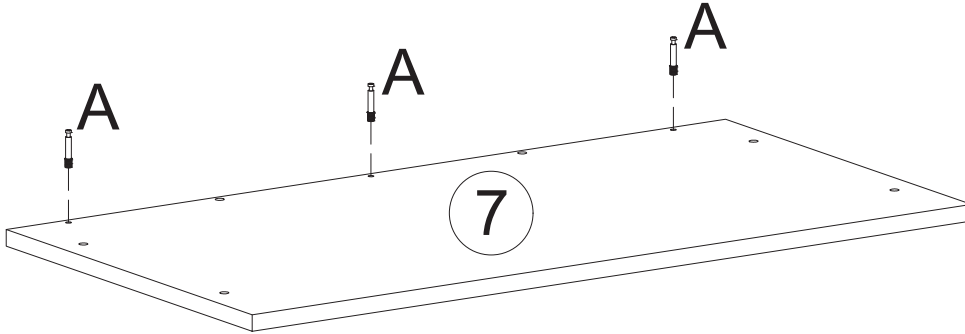
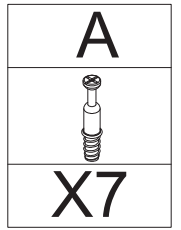

Step 14

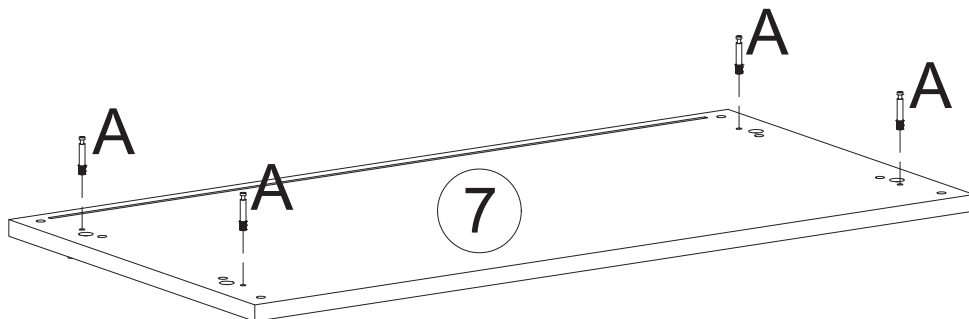
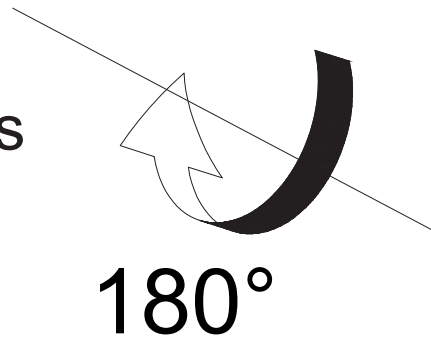

Note: This step involves only ONE Board 7



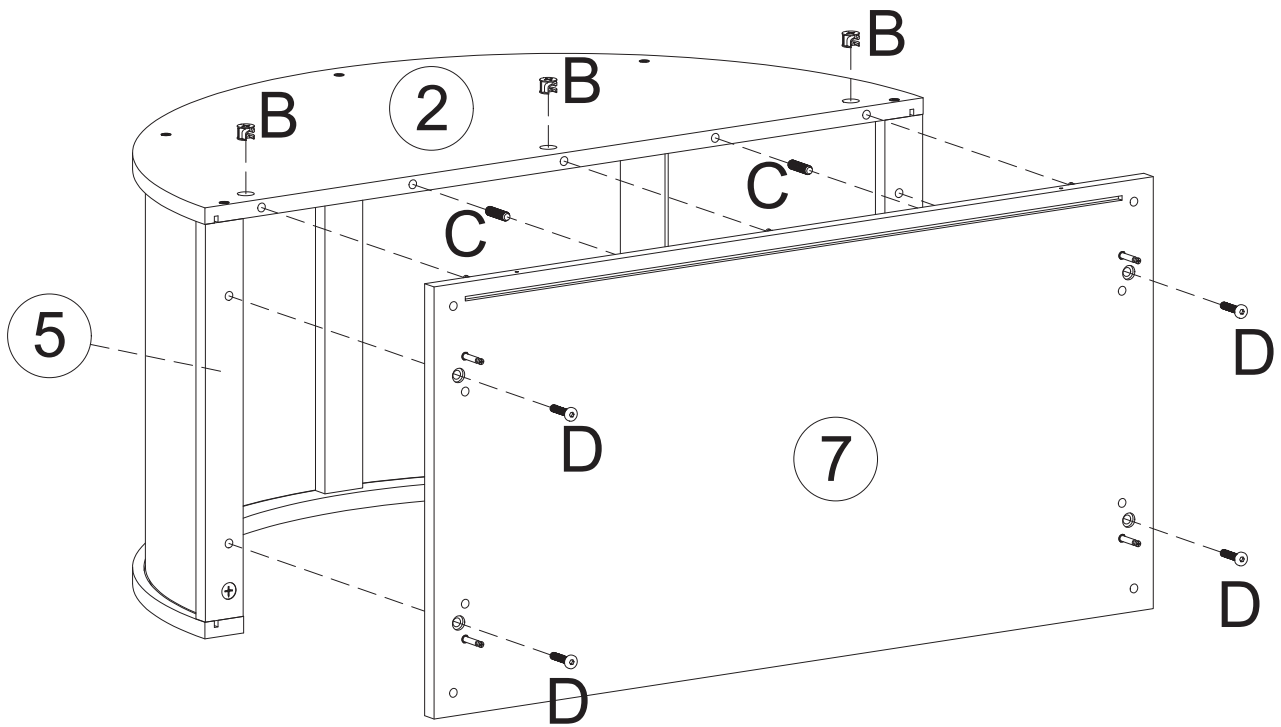

Step 15

B	C	D	P
			
X3	X2	X4	X1



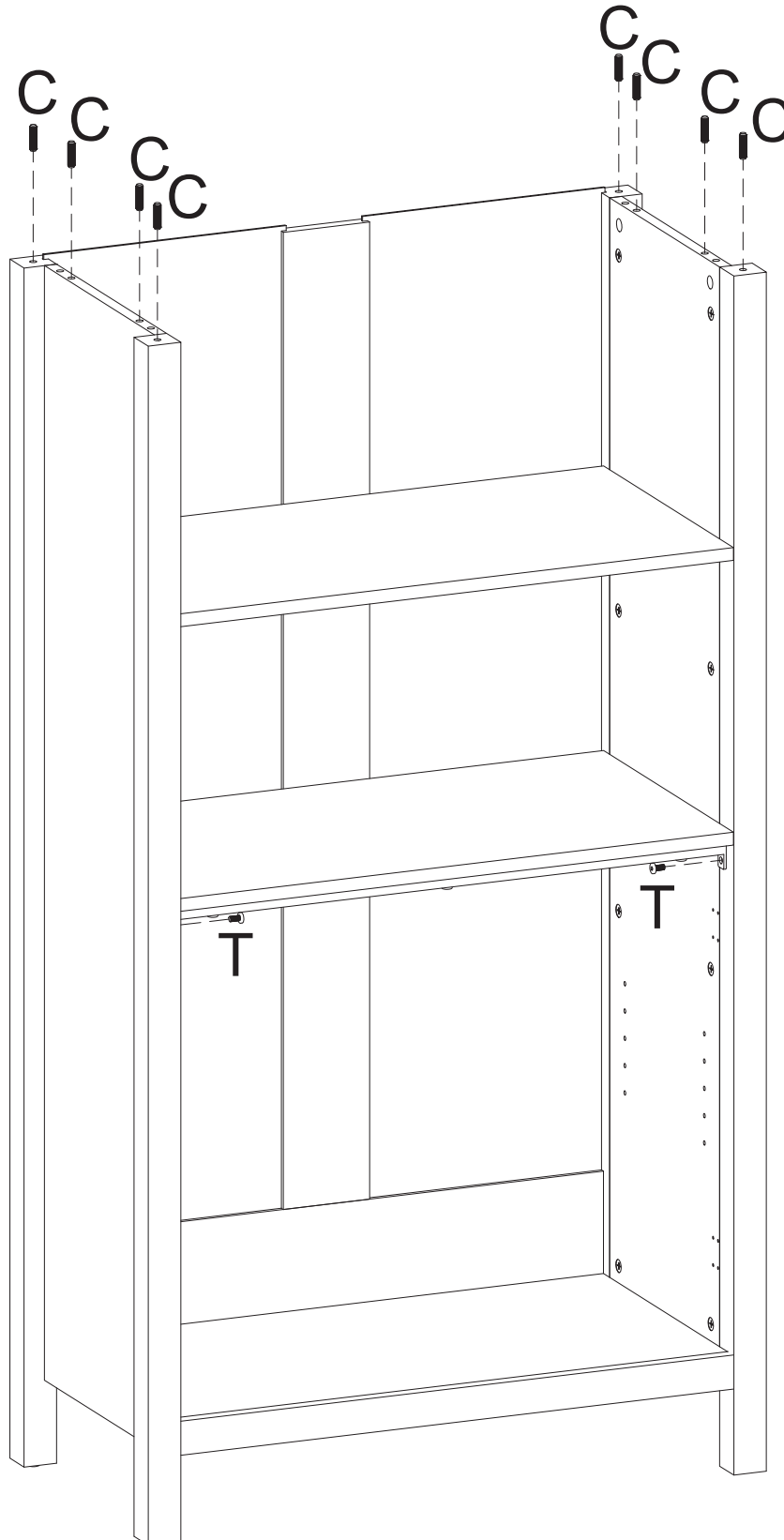

Step 16

C	T	P
		
X8	X2	X1



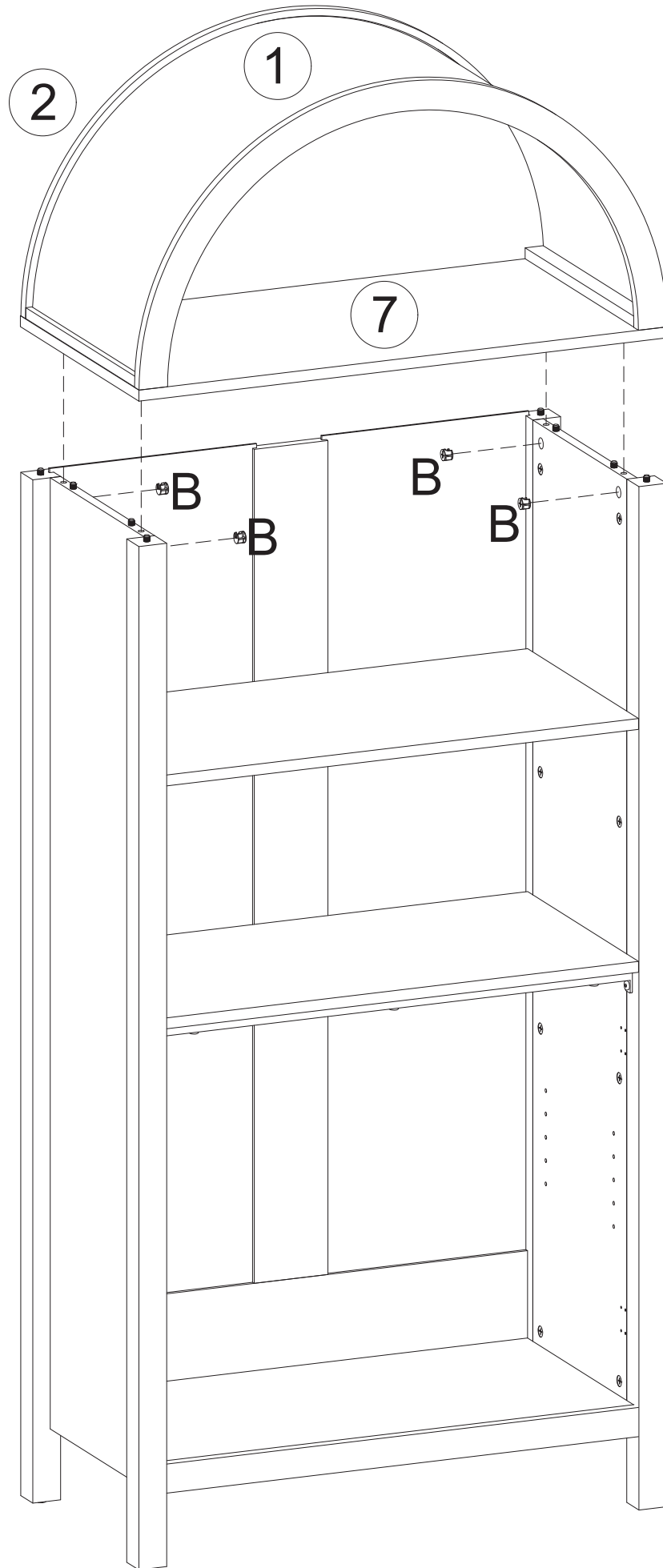

Step 17



B

X4

Step 18

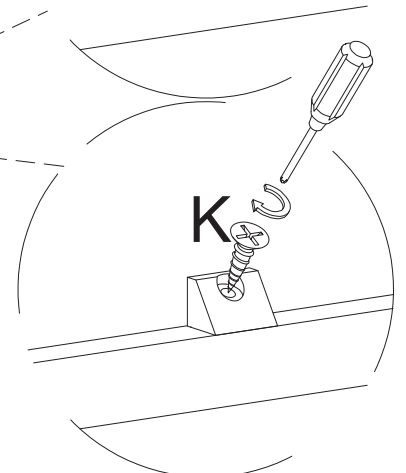
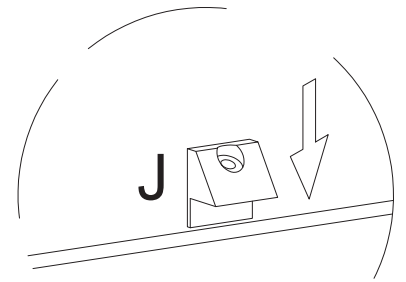
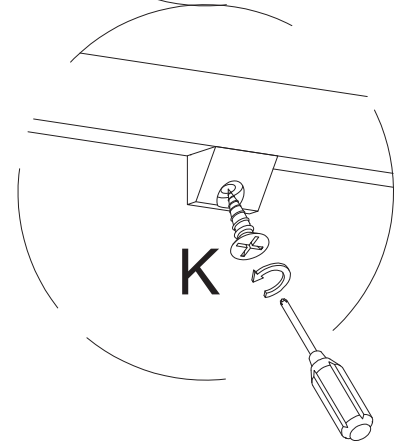
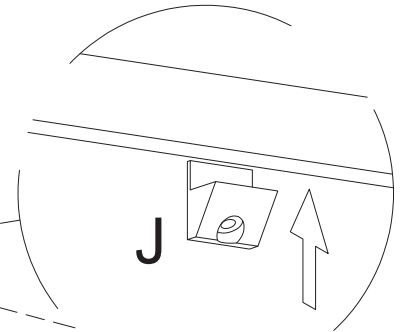
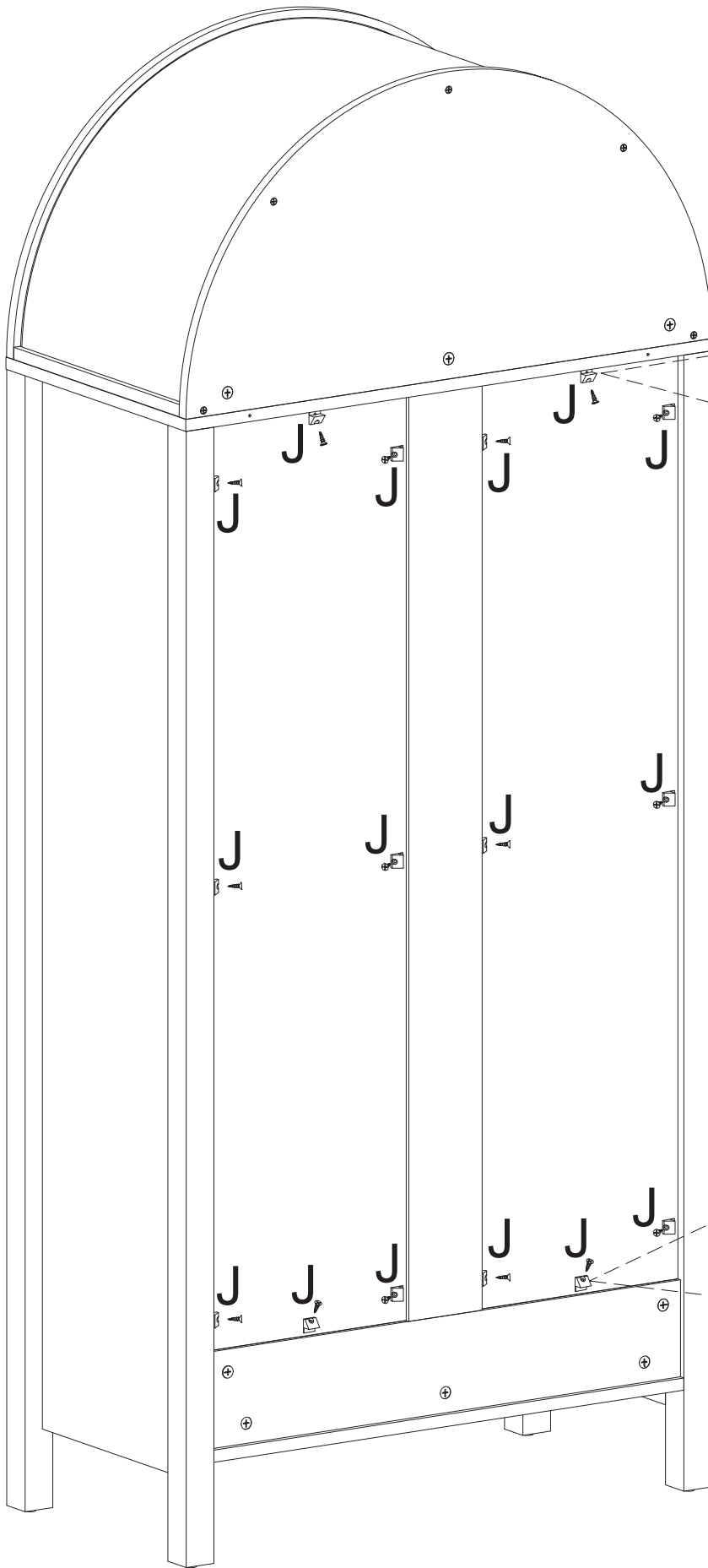
J	K
	
X16	X16



Step 19

NOTE: Please insert #22 boards before installing the door.

E

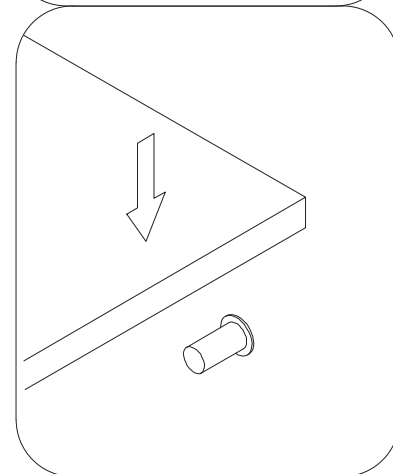
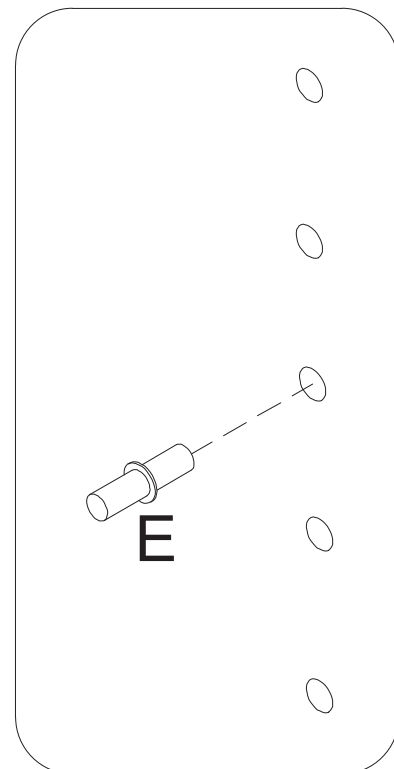
X4





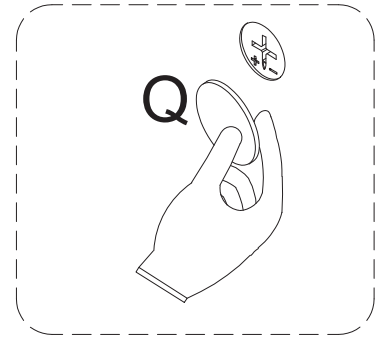
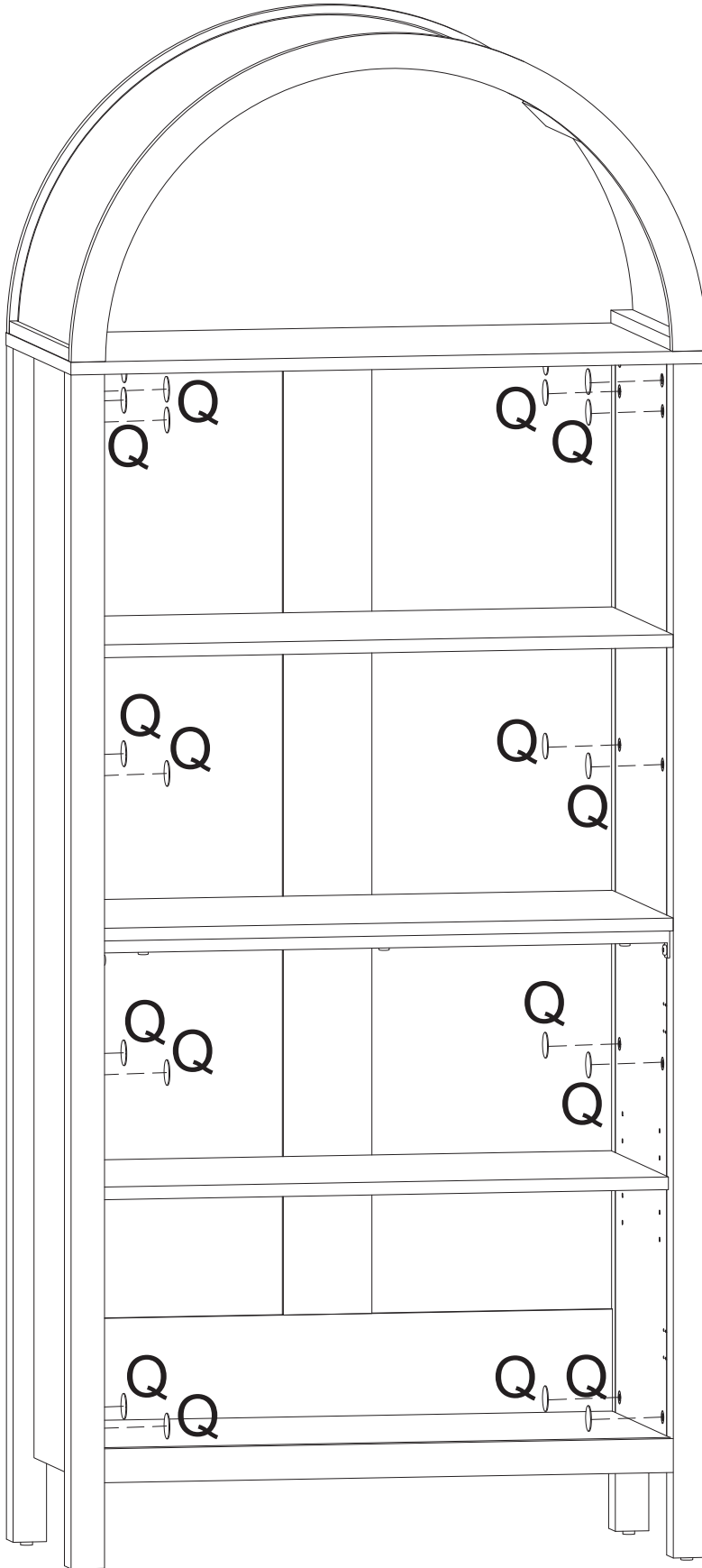

Step 20

Q
○
X20



Step 21

F	G	H	I
			
X4	X8	X2	X4

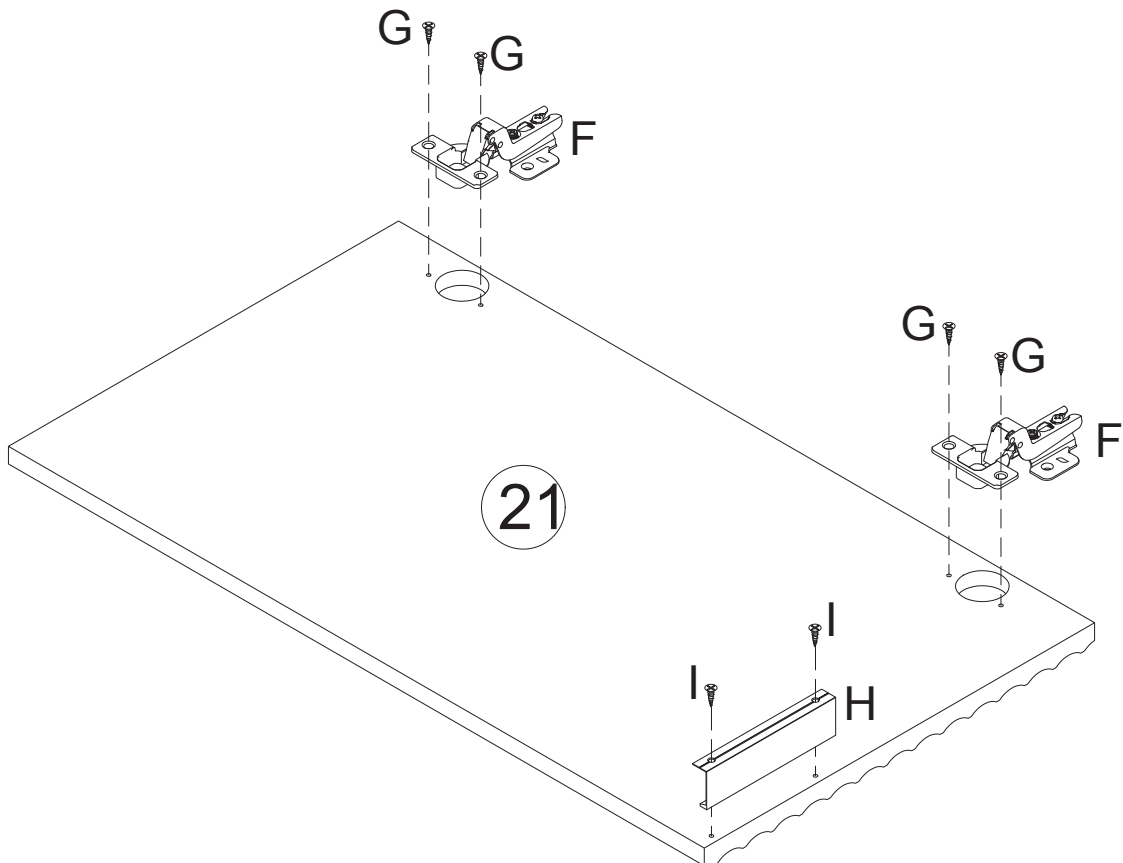
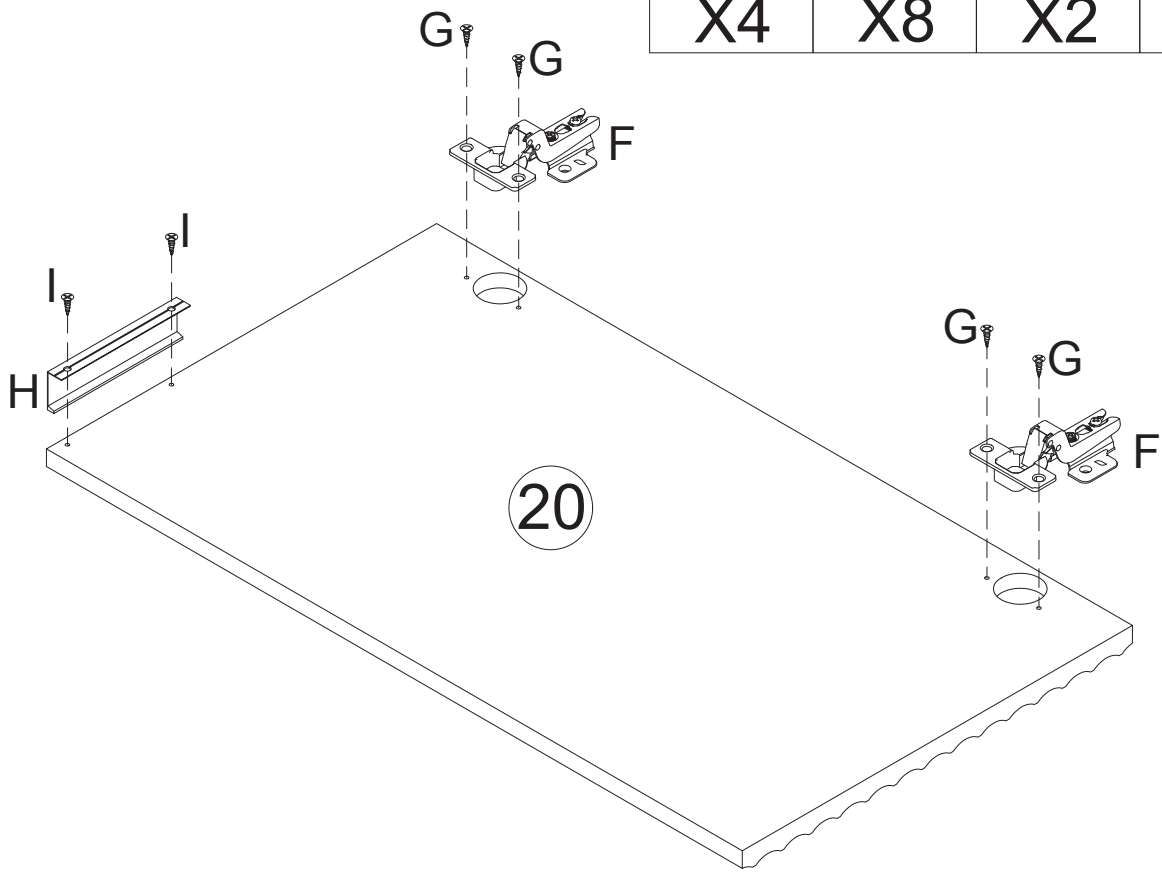

Step 22

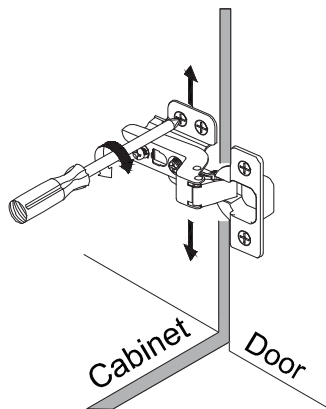
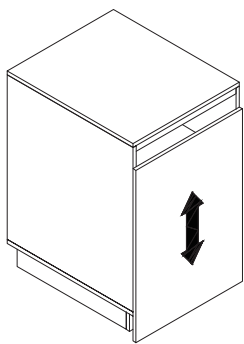
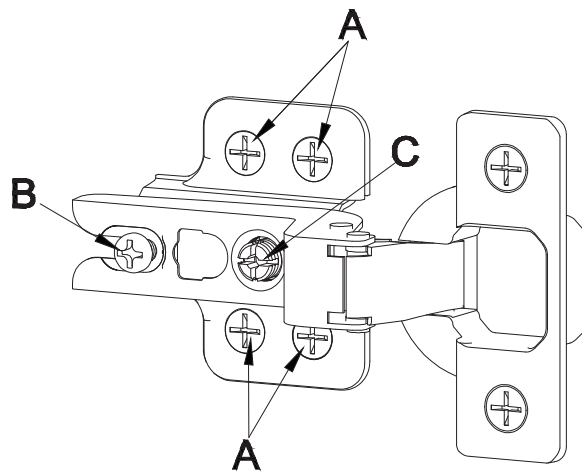

To adjust the vertical height.

Loosen the four screws "A" on both hinges. Two of them are usually in slotted holes which allows you to adjust up or down by a few mm. Then tighten back up.

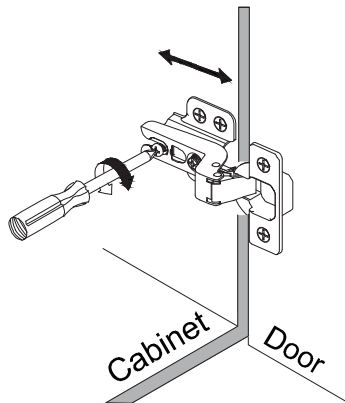
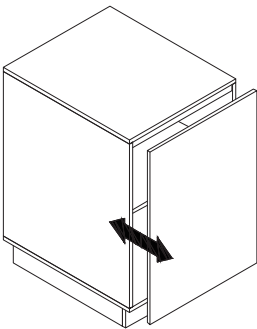

To adjust depth.

Loosen screw "B" and adjust door, if the door can not be adjusted, please loosen screw "C", then try again. Tighten screw "B" and "C".

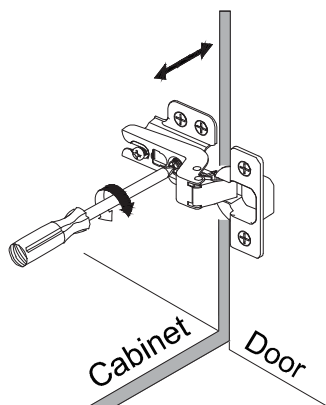
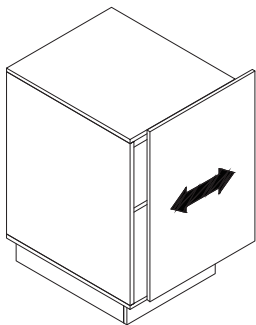



To adjust side ways.

Turning the screw "C" on BOTH hinges on each door.

Step 23

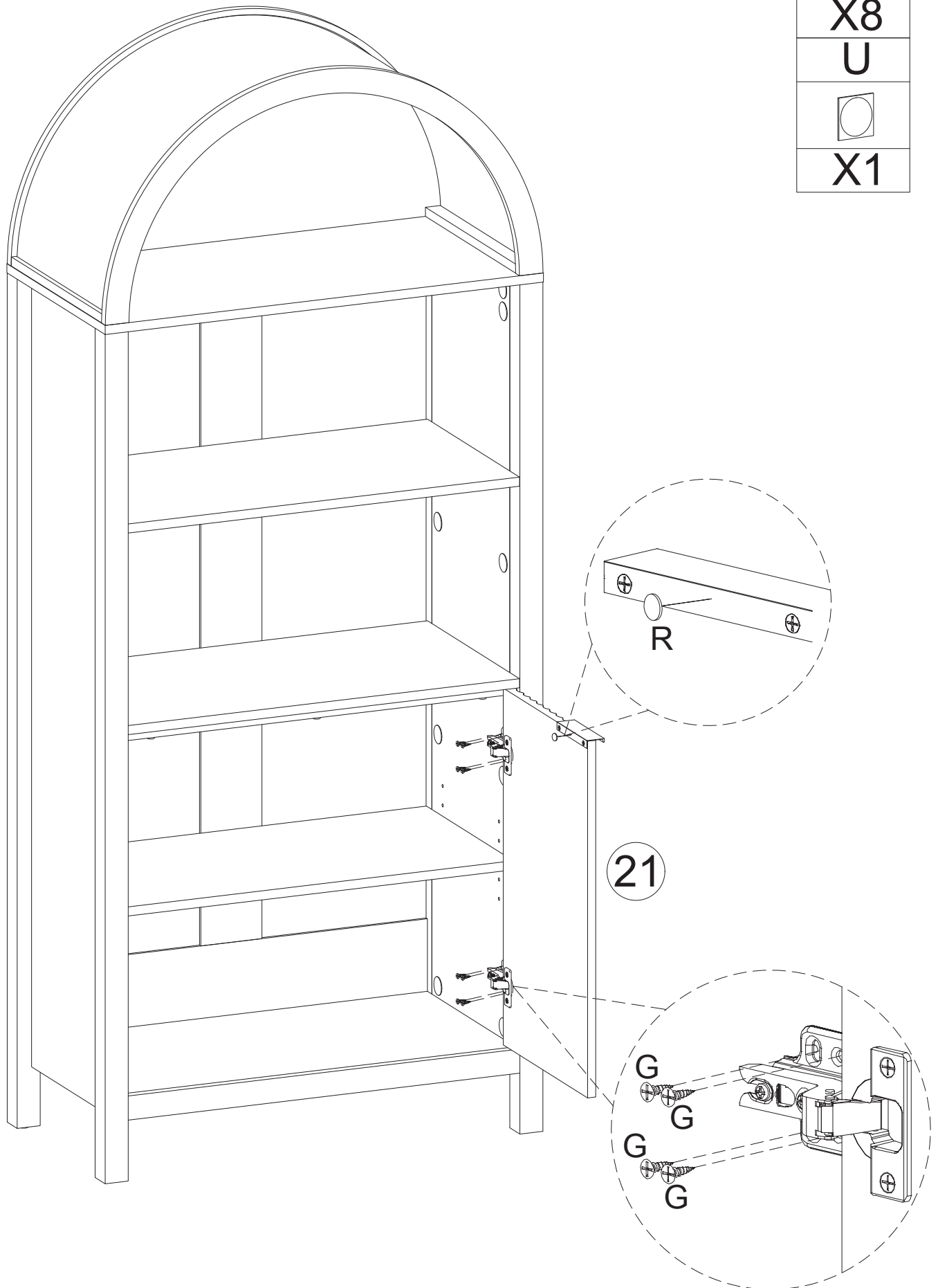

NOTE: The right door is #21. the handle is located above the door

G

X8
U

X1



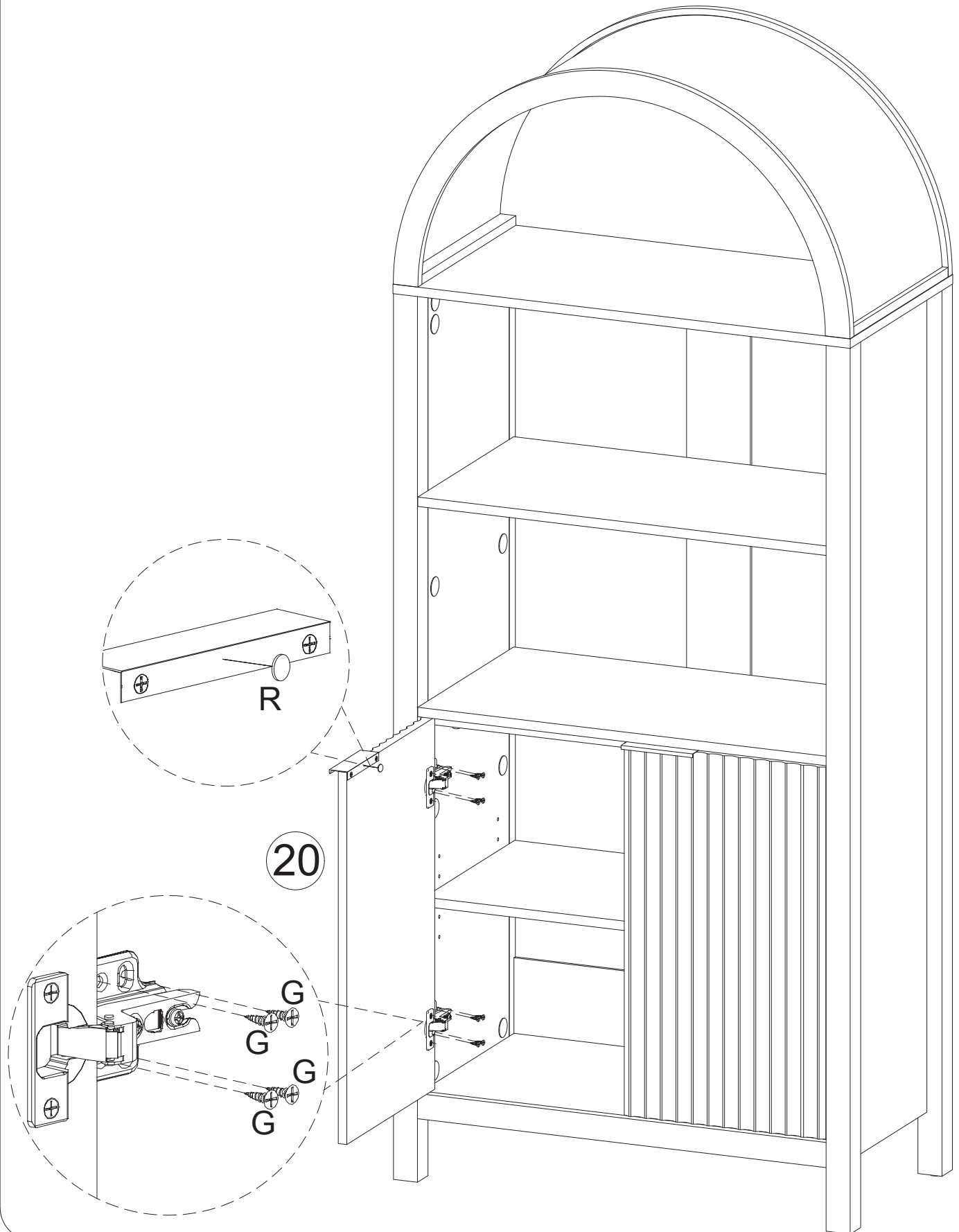

Step 24

NOTE: The left door is #20. The handle is located above the door.

U	G
	
X1	X8



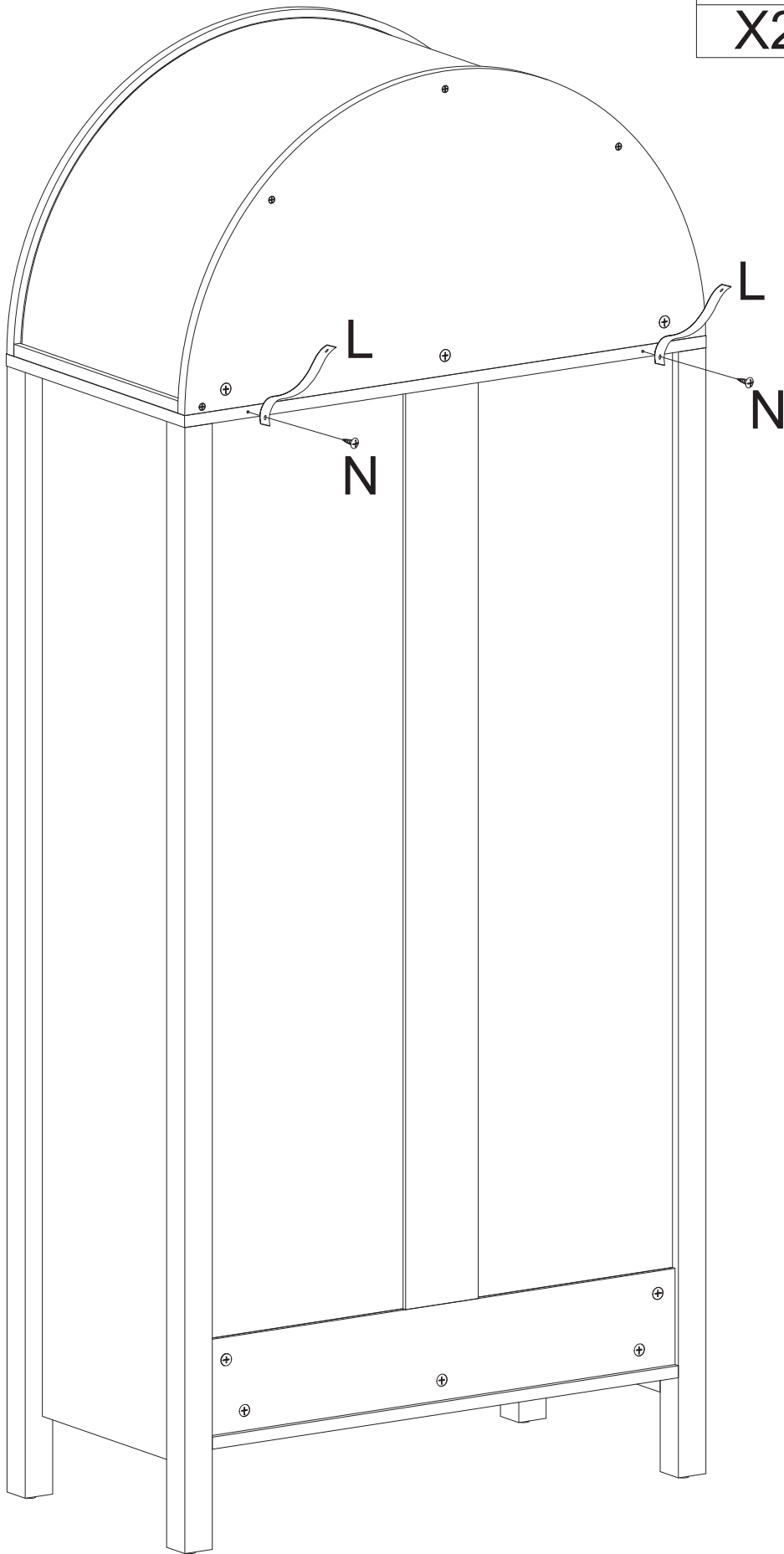

Step 25

L	N
	
X2	X2



Step 26

NOTE: To reduce the risk of furniture tipover.
ALWAYS install tipover restraint provided.

M	O
	
X2	X2

