

- TABLES  
 Cocktail Base  
 Cocktail Glass  
 End Base  
 End Glass

UNLESS OTHERWISE STATED, PLEASE DO NOT TIGHTEN BOLTS (AND/OR) SCREWS UNTIL UNIT IS COMPLETELY ASSEMBLED ON A FLAT SURFACE. Examine all packaging material for small parts that may have come loose during shipment. Periodic checks are recommended to insure that all components are in proper position, tight and free from damage. Keep this assembly instruction for future reference. Adult assembly required.

**PARTS LIST**

- A (1) Table Base
- B (4) Legs
- C (1) Table Top
- D (1) Table Glass

**HARDWARE LIST**

- E (4) Suction Cups
- F (16) Allen Bolts
- G (16) Spring Washers
- H (16) Metal Washers
- I (1) Allen Wrench
- J (4) Adjustable Feet

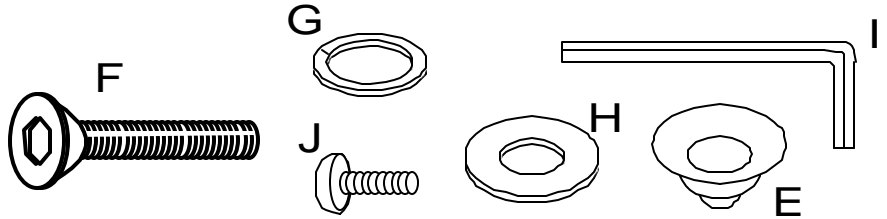

**STEP 1**  
 SCREW IN PLACE 1 ADJUSTABLE FOOT (J) INTO THE BOTTOM OF EACH LEG (B). SEE FIGURE 1.

**STEP 2**  
 FASTEN ALL LEGS (B) TO THE TABLE BASE (C) USING 2 ALLEN BOLTS (F), 2 SPRING WASHERS, AND 2 METAL WASHERS (H). ONLY HAND TIGHTEN FOR THIS STEP. SEE FIGURE 2.

**STEP 3**  
 FASTEN TABLE BASE (A) TO ALL 4 LEGS (B) USING 1 ALLEN BOLT (F), 1 SPRING WASHER (G), 1 METAL WASHER (H) PER LEG. TIGHTEN ALL BOLTS FROM THIS STEP AND STEP 1.

**STEP 4**  
 INSERT SUCTION CUPS (E) INTO HOLES ON TOP OF THE TABLE TOP.

**STEP 5**  
 CAREFULLY CENTER THE GLASS (D) ON TOP OF SUCTION CUP (E).

FIGURE 1

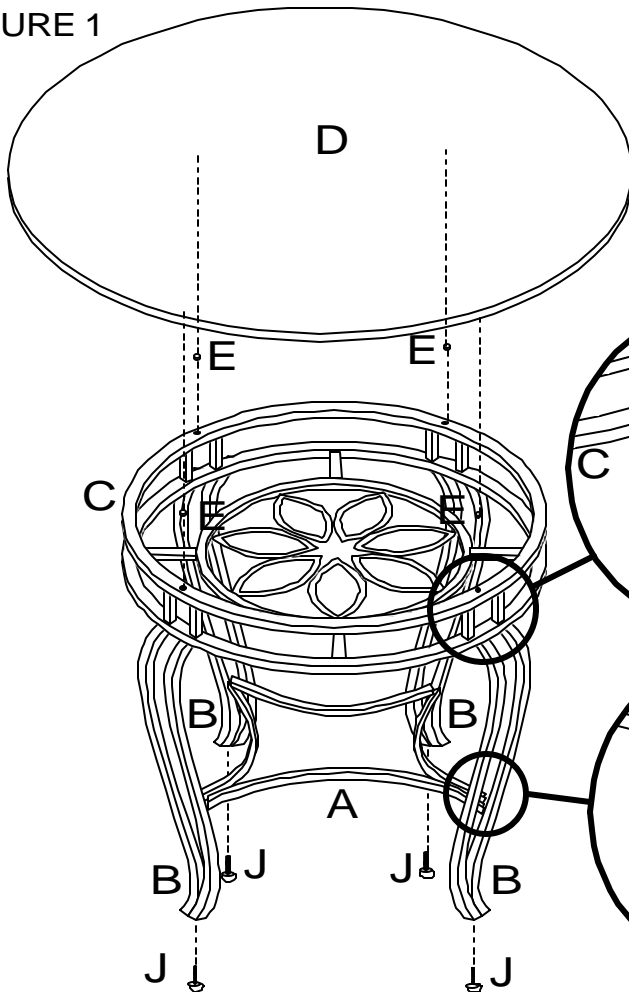

FIGURE 2

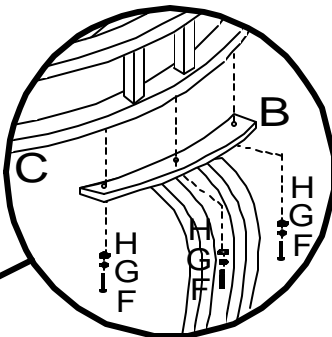
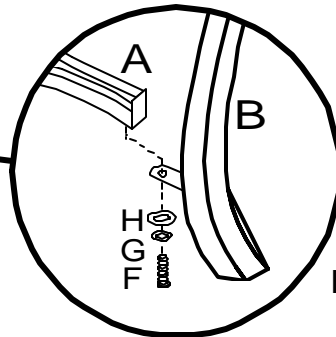

FIGURE 3



**CARE & MAINTENANCE:** The touch of a soft cloth is all the maintenance the finish of your new item will ever need. Never use harsh or abrasive cleaners for polishing. Periodic checks are recommended to make sure that all bolts, screws and nuts are securely tightened.