

ASSEMBLY INSTRUCTIONS



Fine Furniture for every stage of life

Dining Side Chair

REVISION 0: 05/08/2019
REVISION 1: 11/30/2023

ASSEMBLY INSTRUCTIONS

ASSEMBLY TIPS :

1. Remove hardware from box and sort by size.
2. Please check to see that all hardware and parts are present prior to start of assembly.
3. Please follow attached instructions in the same sequence as numbered to assure fast & easy assembly.



WARNING !



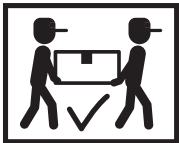



1. Don't attempt to repair or modify parts that are broken or defective. Please contact the store immediately.
2. This product is for home use only and not intended for commercial establishments.

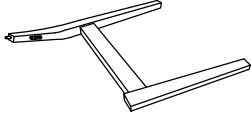
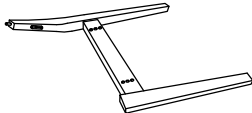

ASSEMBLY TIME

15 MINUTES

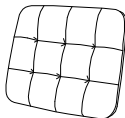
PARTS IDENTIFICATION

A	RIGHT LEG FRAME		1PC
B	LEFT LEG FRAME		1PC
C	FRONT RAIL (LONG)		1PC
D	BACK RAIL (SHORT)		1PC
E	BACKREST		1PC
F	BACK CUSHION (SMALL)		1PC
G	SEAT CUSHION (BIG)		1PC

ASSEMBLY INSTRUCTIONS

ASSEMBLY TIPS :





1. Remove hardware from box and sort by size.
2. Please check to see that all hardware and parts are present prior to start of assembly.
3. Please follow attached instructions in the same sequence as numbered to assure fast & easy assembly.

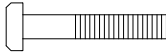

WARNING !

1. Don't attempt to repair or modify parts that are broken or defective. Please contact the store immediately.
2. This product is for home use only and not intended for commercial establishments.

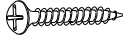
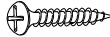
HARDWARE IDENTIFICATION

1	ALLEN WRENCH (M4 x 110mm - BLK)		1PC
2	BOLT (M6 x 40mm - RBW)		4PCS
3	LOCK WASHER (1/4" - BLK)		4PCS
4	LONG PAN HEAD SCREW (#8 x 1-1/4" - BLK)		4PCS
5	SHORT PAN HEAD SCREW (#8 x 1" - BLK)		4PCS
6	CAM BOLT (263.20.847 - ZB)		2PCS
7	WOOD DOWEL (M8 x 30mm)		1PC

NOTE:

Phillips head screw driver is required in the assembly process; however, manufacturer does not provide this item. Quantities shown are for one chair.

ASSEMBLY INSTRUCTIONS

STEP 1

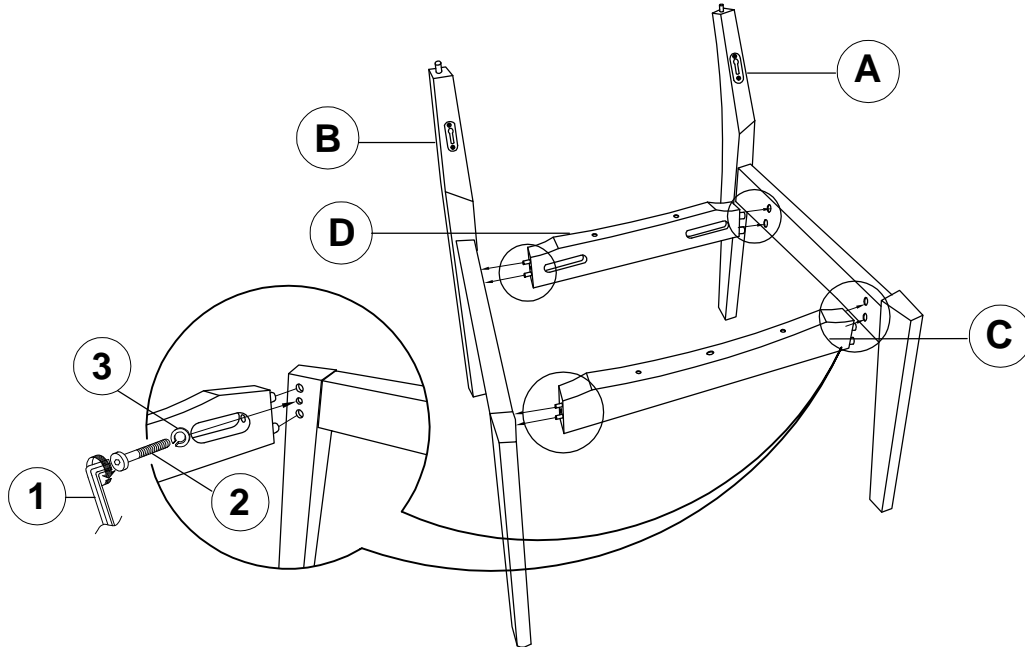

STEP 2

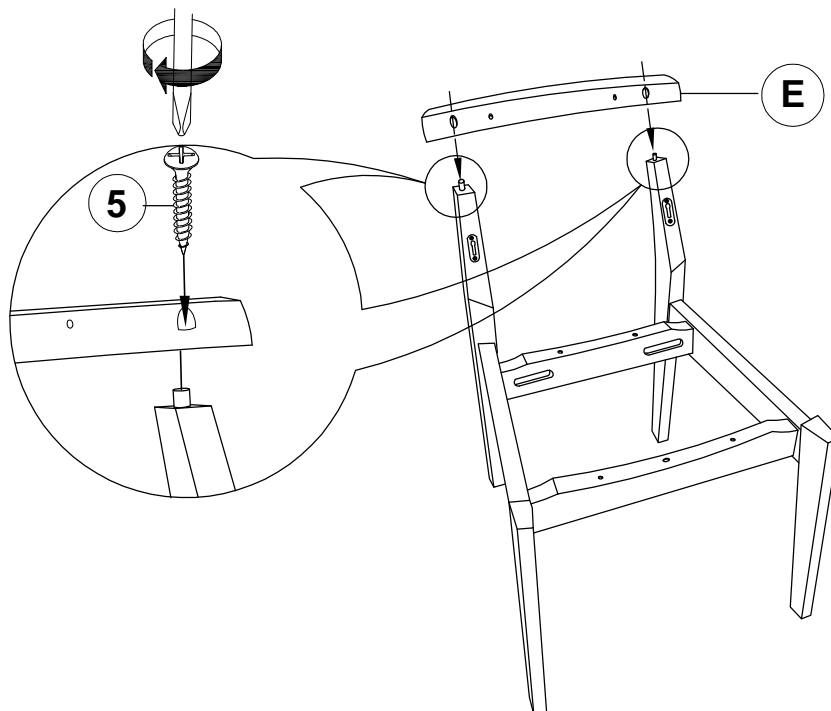

ASSEMBLY INSTRUCTIONS

STEP 3

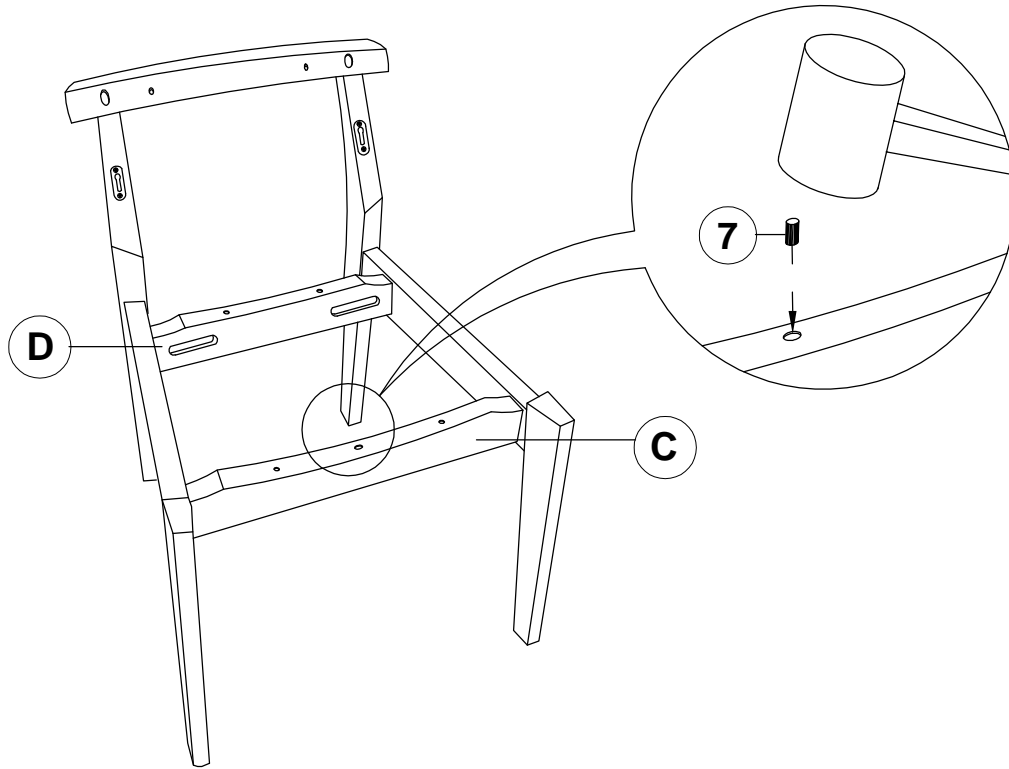

STEP 4

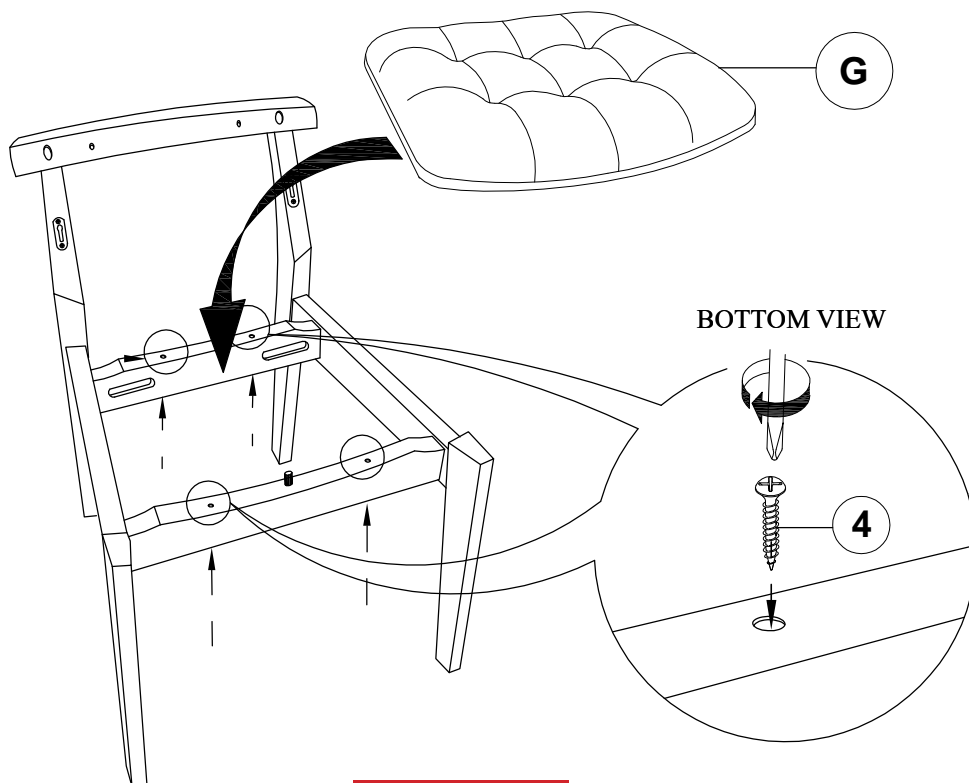

ASSEMBLY INSTRUCTIONS

STEP 5

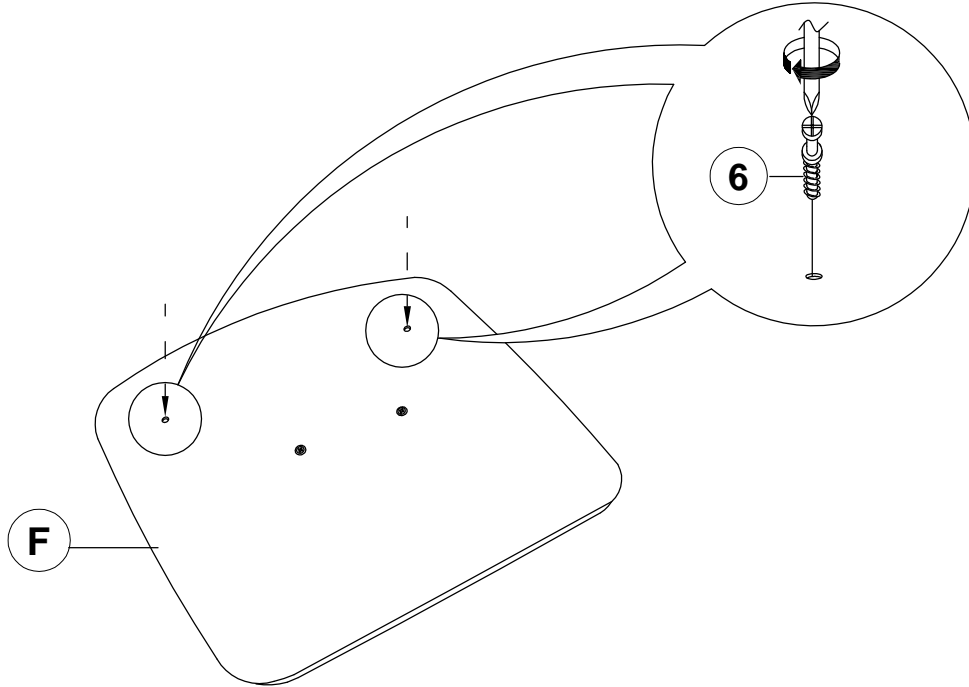

STEP 6

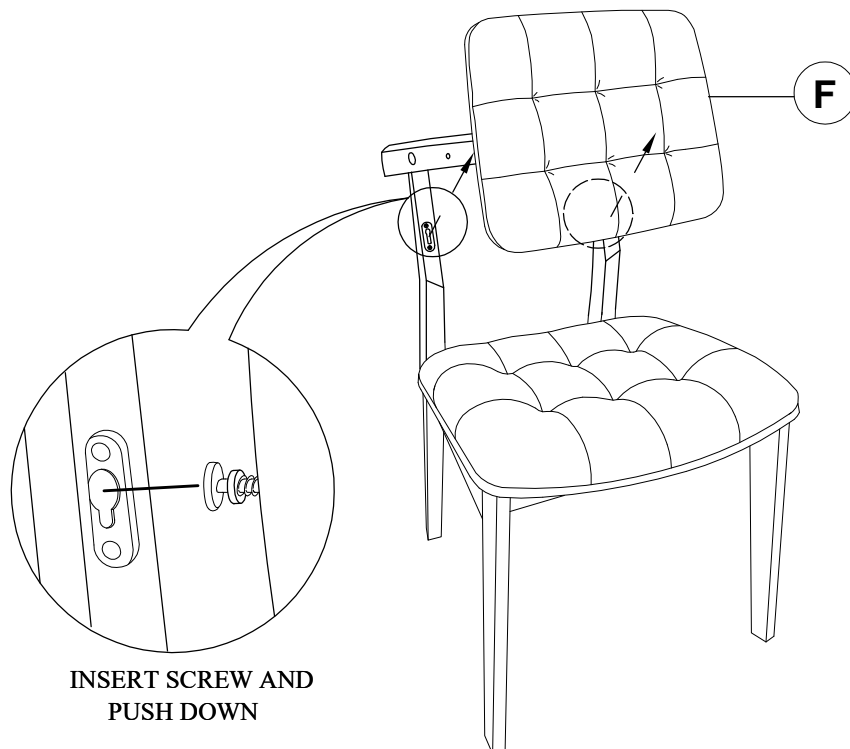

ASSEMBLY INSTRUCTIONS

STEP 7

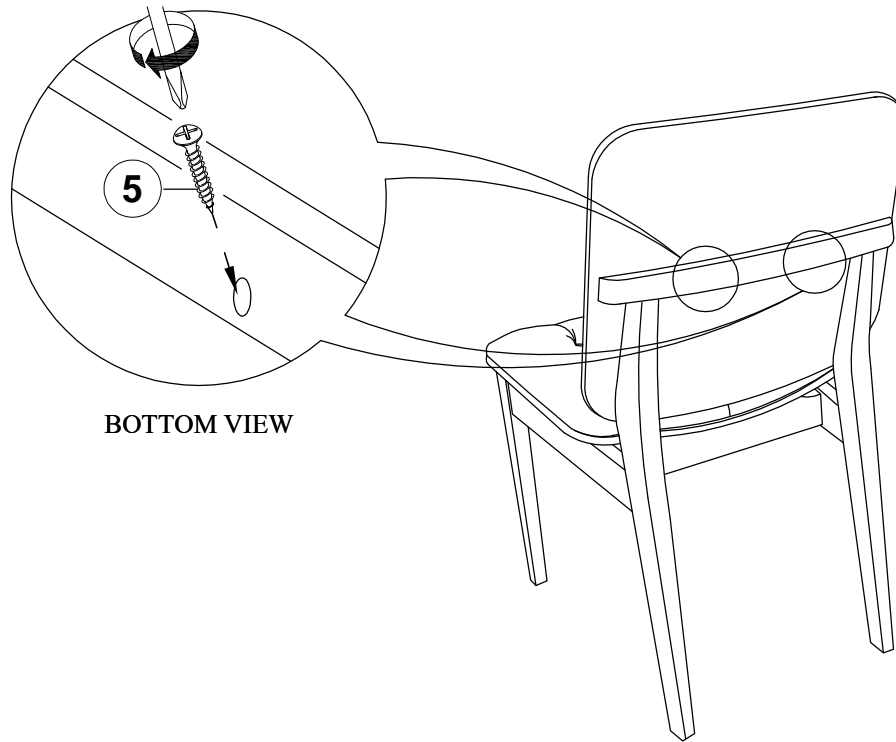

BOTTOM VIEW

STEP 8 COMPLETE

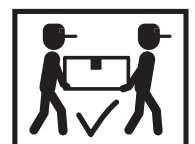
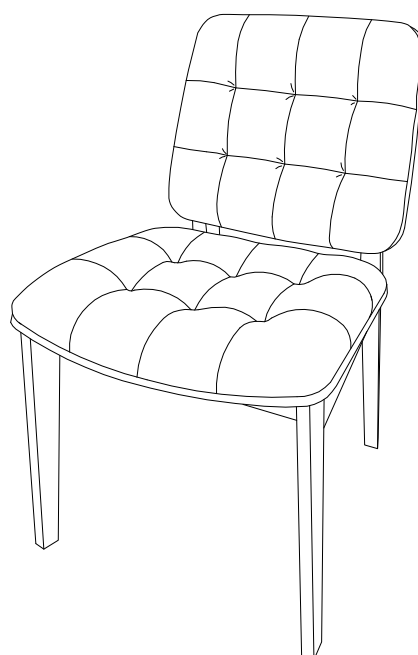

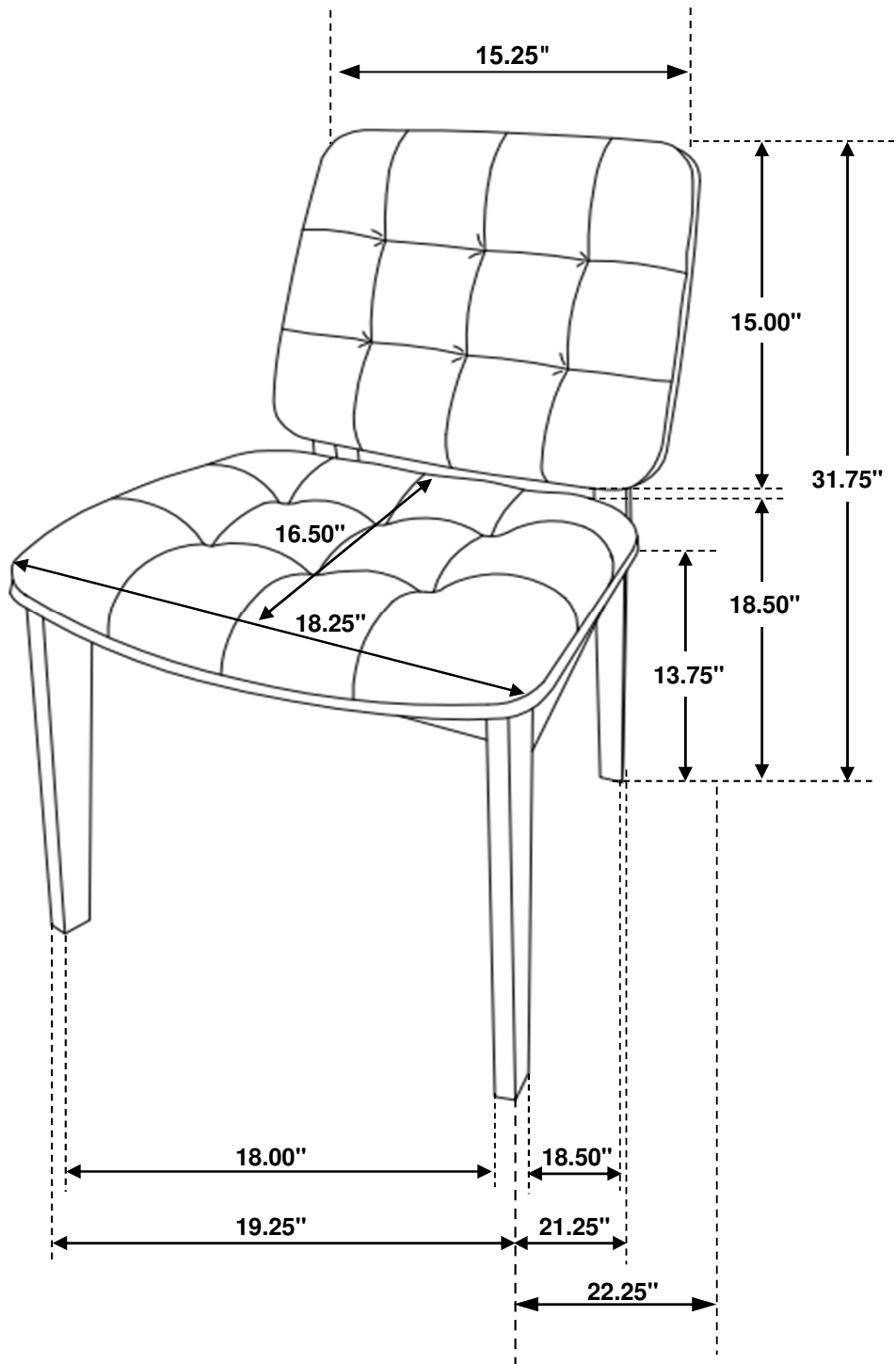

Note: Dimension tolerance $\pm 5\%$