

NOTICE

* Please make sure that you have all parts indicated and they are in good condition before you begin assembly of this item. Refer to part list and hardware list below for guidance.

* This item should be assembled on a soft surface to prevent scratching the finish during assembly.

* This item may require periodic tightening.

* If you are having difficulty, our friendly Customer Care team is always here to help.

PREPARATION

* Before beginning assembly of product, make sure all parts are present.

Compare parts with part contents list and hardware contents list.

* If any part is missing or damaged, do not attempt to assemble the product.







* Estimated assembly time : **15 minutes.**

* Tools required for assembly (included) : **Allen key**

CARE AND MAINTENANCE

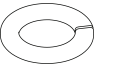
Always use felt pads under all articles to prevent discoloration or softening of the lacquer. Plastic and rubber bases on items can discolor wood. Wipe up spill immediately and avoid common hazards such as hot dishes, harsh solvents and abrasives. Cleaning should be done with a soft lint free cotton cloth dampened with water or furniture polish. On highly used surface we recommend applying a quality paste wax which should be used on a regular basis to provide additional protection from scratches and spills. How often you apply the wax depends on how much wear the furniture receives.

Part List and Hardware List

PIECE	DESCRIPTION	PICTURE	QUANTITY
A	Table Top		1x
B	Table Leg		4x
HW 1	Spring Washer 8mm		8x
HW 2	Flat Washer 8mm		8x
HW 3	Jcbb Bolt M8 x 0.5 x 70mm		8x
HW 4	Allen key		1x

Product Dimensions : 47.24”(29.52”) W x 29.52” D x 29.13” H

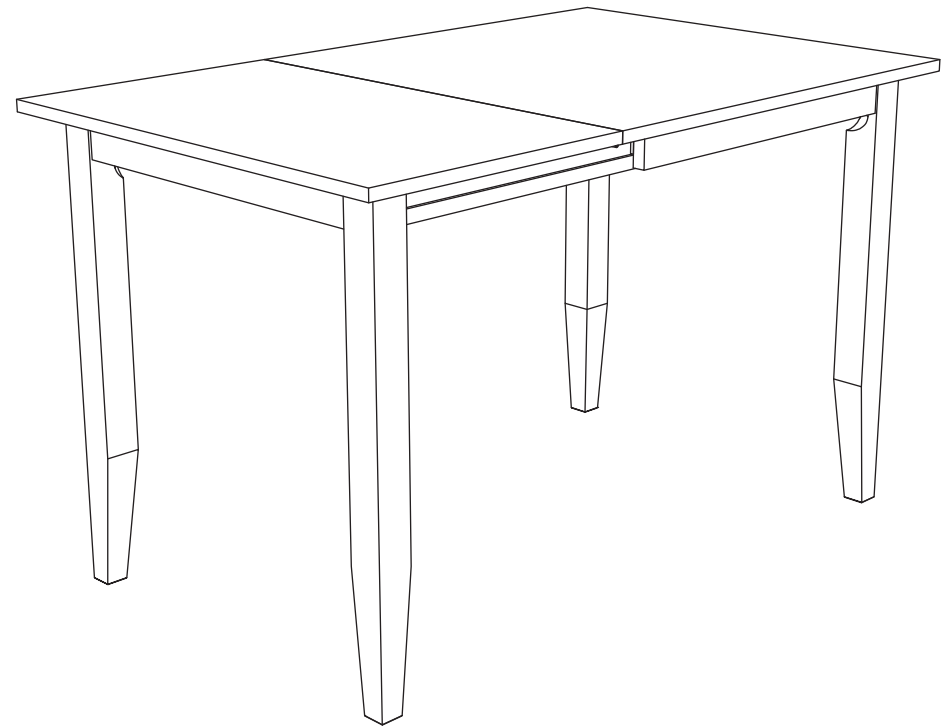

Weight capacity - 127 LBS

Warning : Do not stand on table.

Warning : Do not over torque bolts.

PREPARATION

- * Before beginning assembly of product, make sure all parts are present. Compare parts with part contents list and hardware contents list.
- * If any part is missing or damaged, do not attempt to assemble the product.
- * Estimated assembly time : 15 minutes
- * Tools required for assembly (included) : Allen key
- * If you are having difficulty, our friendly Customer Care team is always here to help. Please email customersupport@safavieh.com

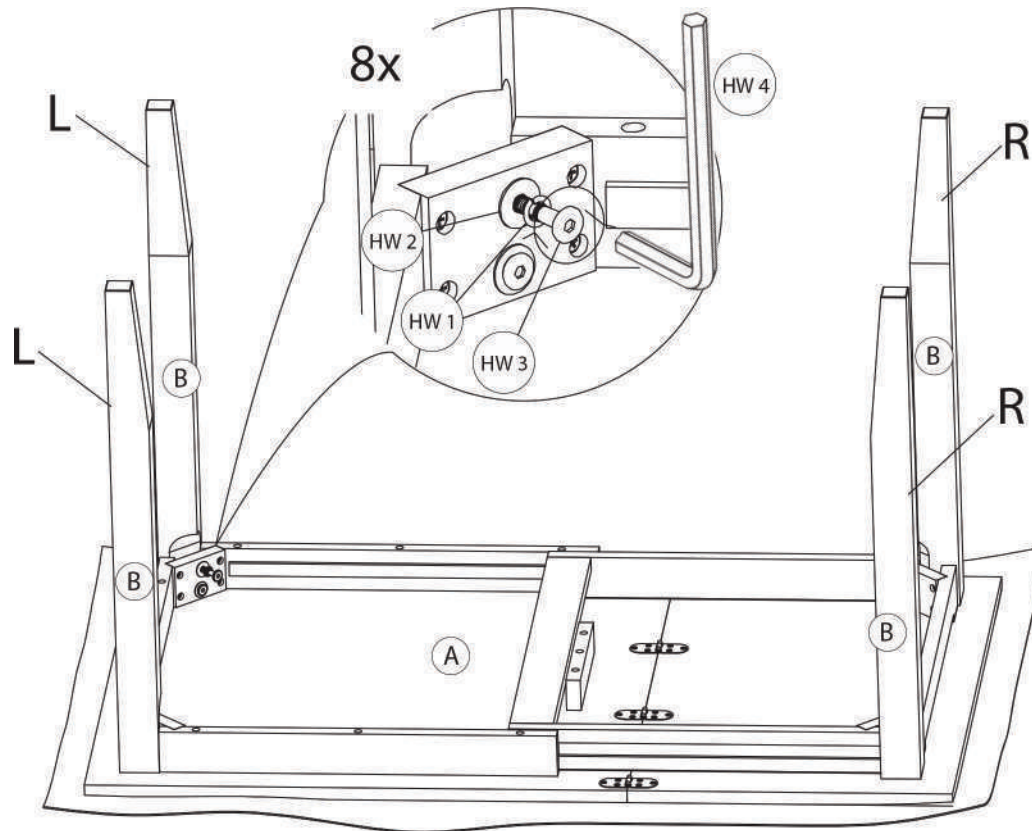

Note:
Refer marking to know
which one left side and right
side leg



Step 1 : Put the table top upside down on a clear and smooth surface to avoid scratch on the table surface. Place the table leg (B) in position and screw in all the bolts (HW3). Put the washer (HW1, HW2) on the bolts (HW3) in the order shown in the picture.

HOW TO USE

How to Close :

Pull up the extend table top with the small force,
then push the leg frame.

How to Open :

Pull up the extend table top until straight, then
pull the leg frame.

