

# DESK

\*\*\*

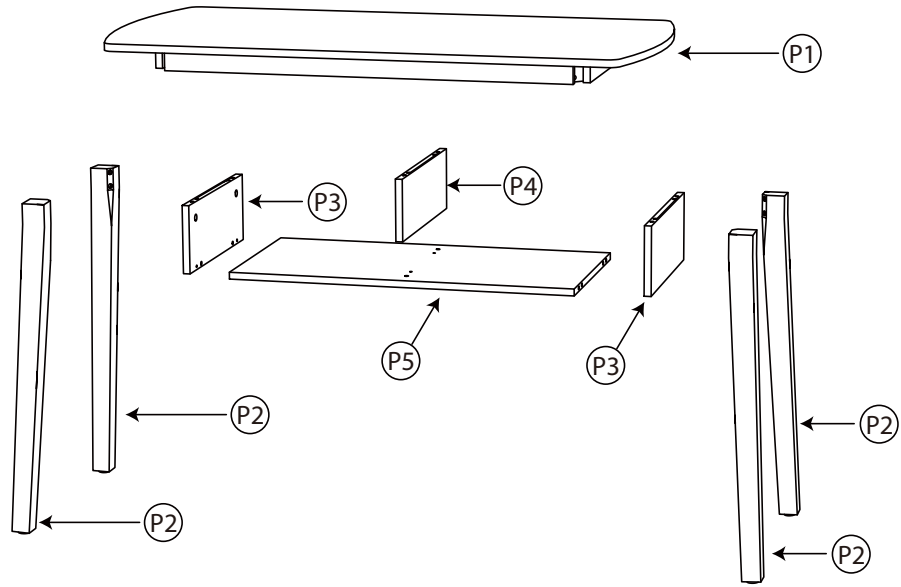

\*\*\*

\*\*\*

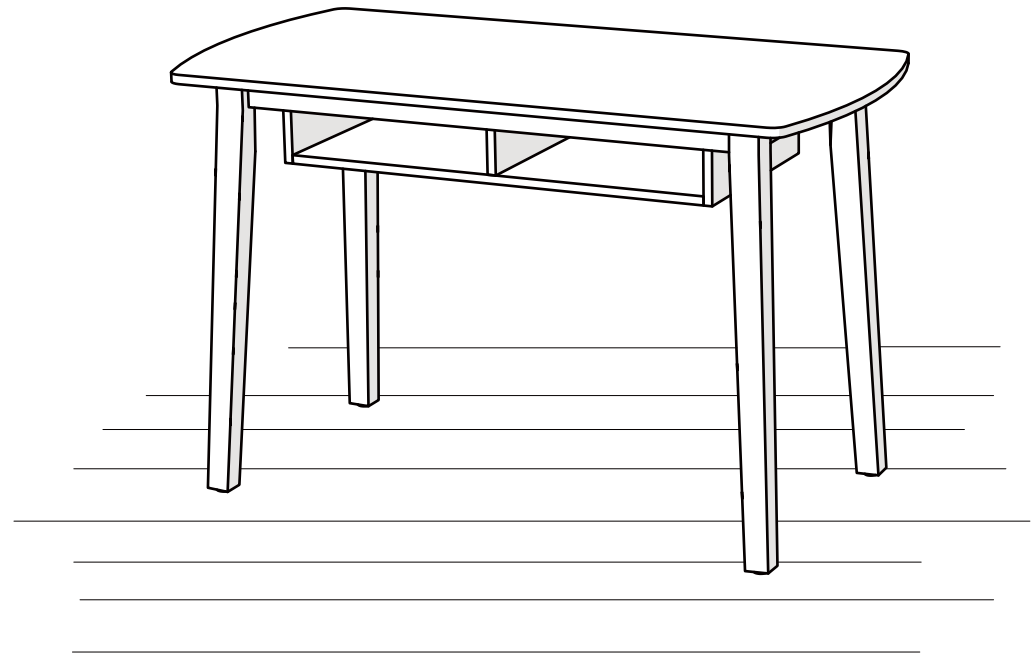

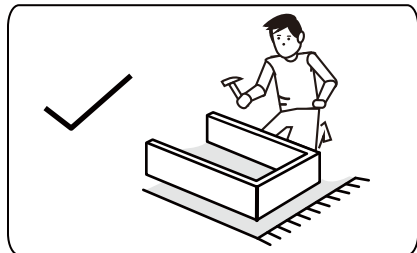
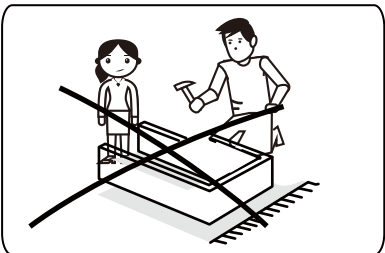
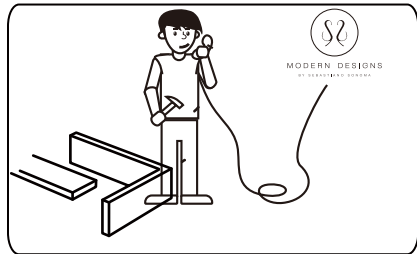
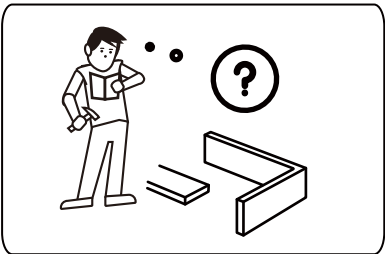
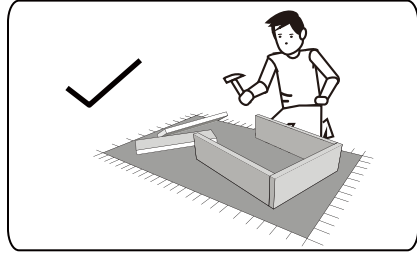
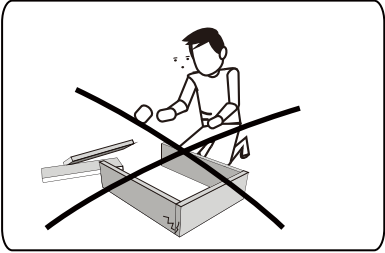
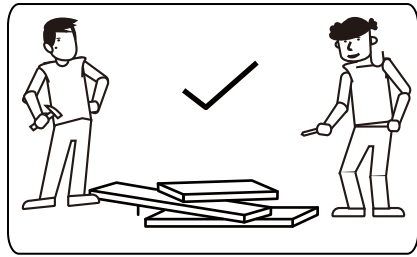
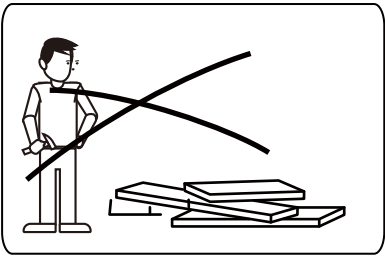

### IMPORTANT NOTES

1. Place all wooden parts on a clean and smooth surface such as a rug or carpet to avoid the parts from being scratched.
2. Check to be sure that you have all parts and hardware.
3. Remove all wrapping materials, including stopples & packing straps before you start assemble.
4. Keep all hardware parts out of reach of children

### STEP:04

- A] Attach P3 With P1
- B] Attach P5 With P4

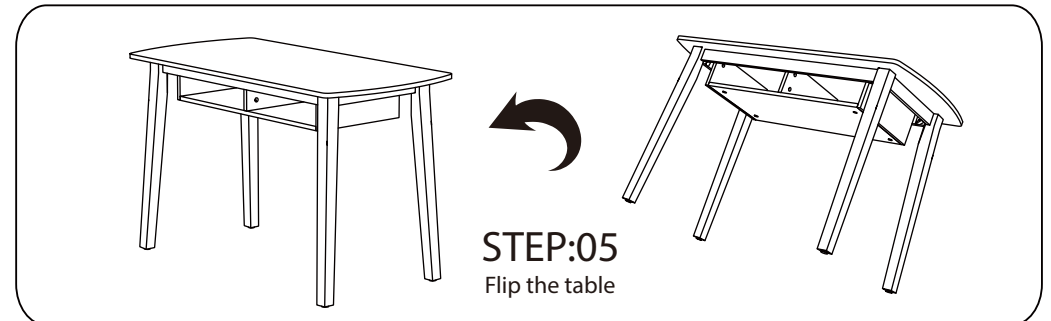
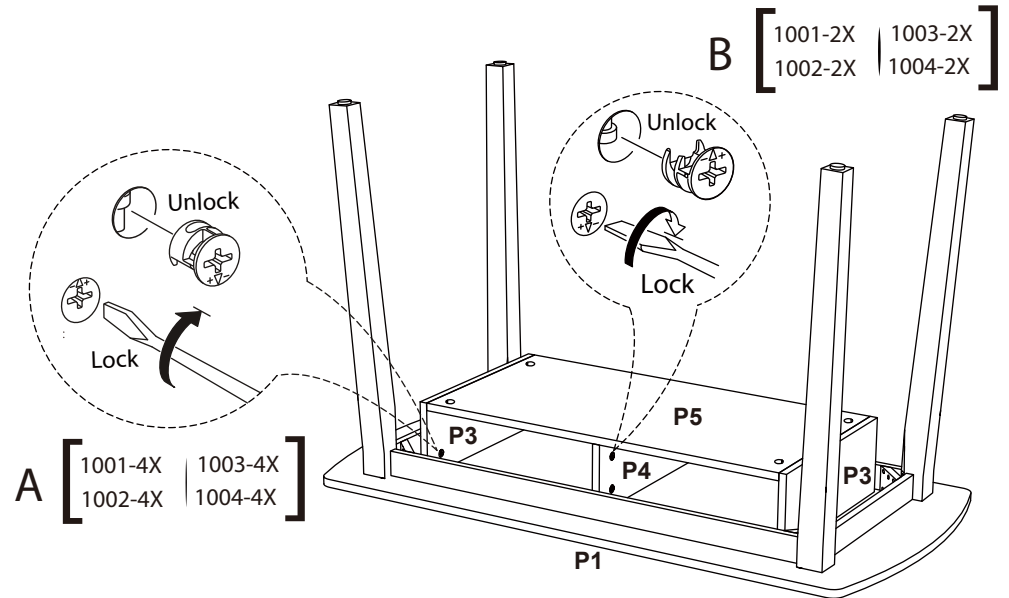
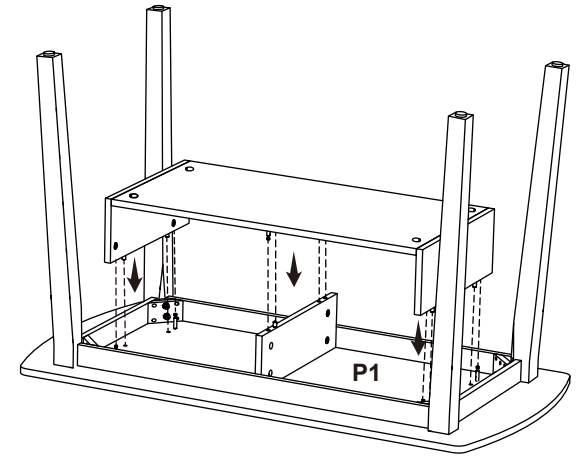

### STEP:05

Flip the table

Partition Assembly

**STEP:02**

Attach P4 With P1

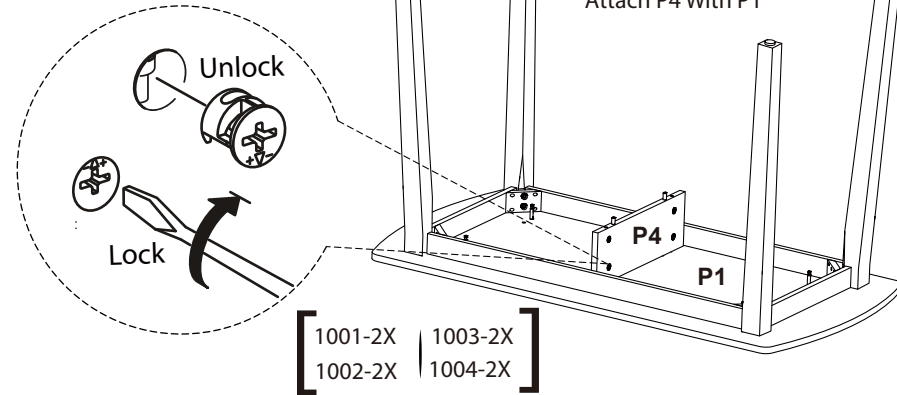

**HARDWARE & TOOL DETAILS**

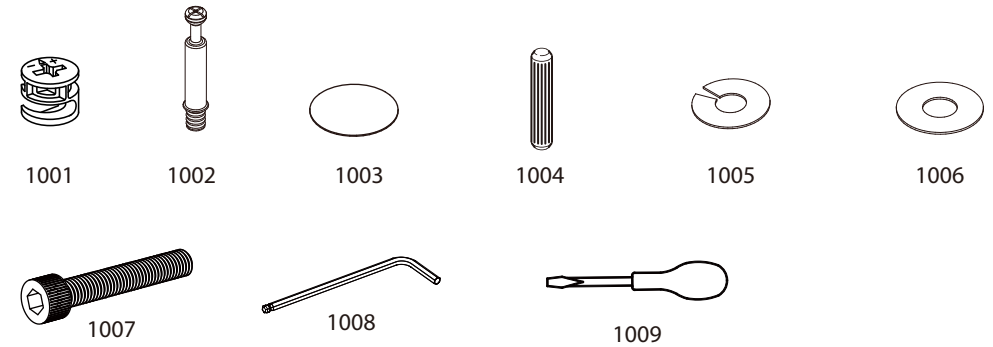

CODE	NAME	QTY	EXTRA
1001	CAM LOCK	12 pcs	0
1002	CAM PIN	12 pcs	0
1003	CAM COVER	12 pcs	0
1004	DOWEL	12 pcs	0
1005	SPRING GASKET	08 pcs	0
1006	GASKET	08 pcs	0
1007	SCREW	08 pcs	0
1008	M6 SPANNER	01 pcs	0
1009	STAR SCREW-DRIVER	NOT PROVIDED	

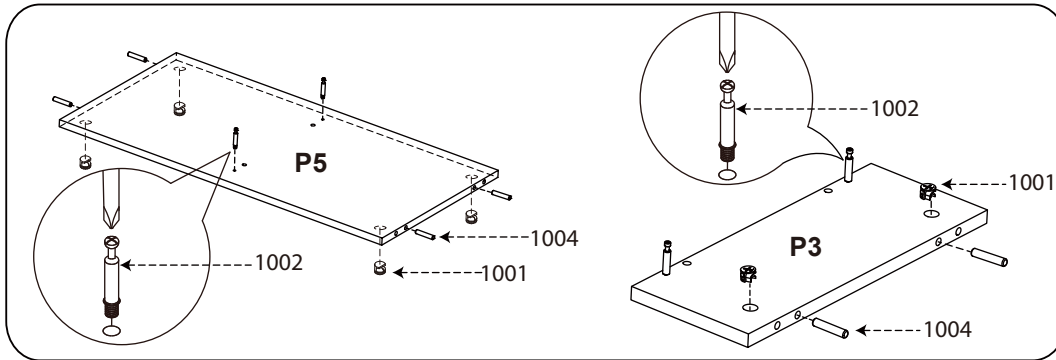

**STEP:03**

Attach P3 With P5

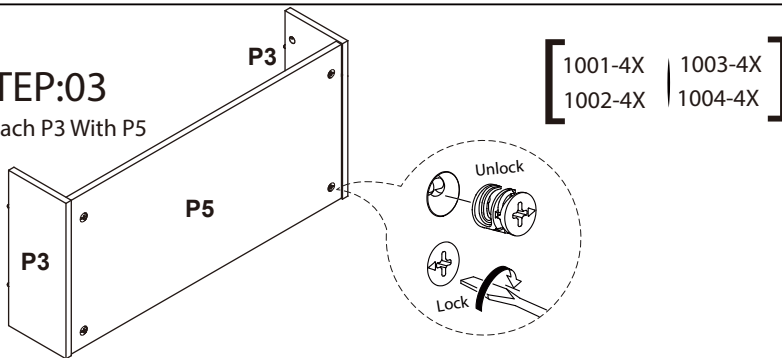

**COMPONENT DETAILS**

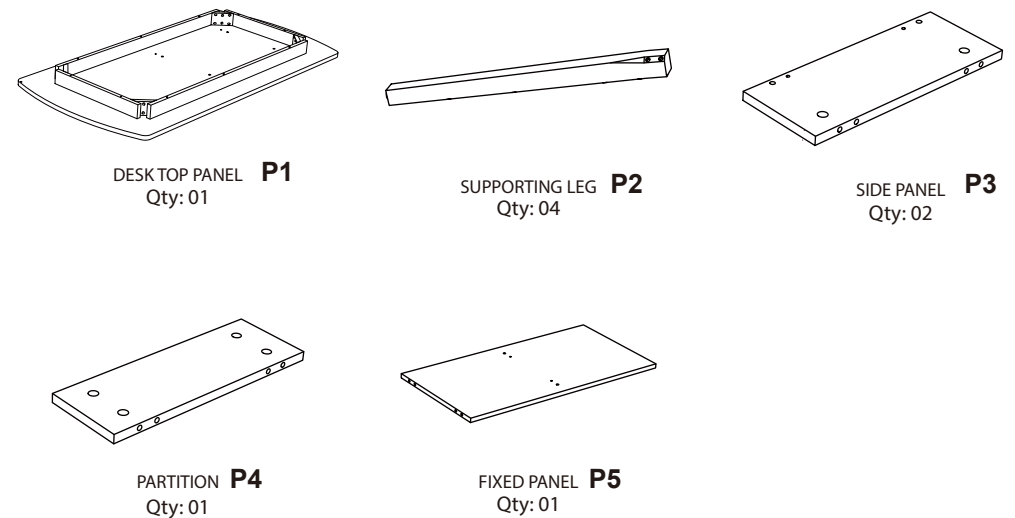

**[ REMEMBER ]**

Use Cam cover-1003  
After  
Using Cam Lock-1001

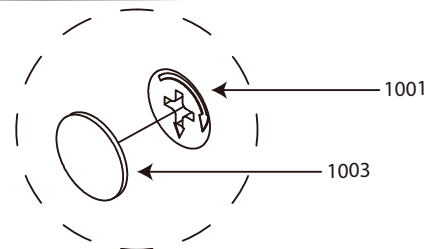

# ASSEMBLY OVERVIEW

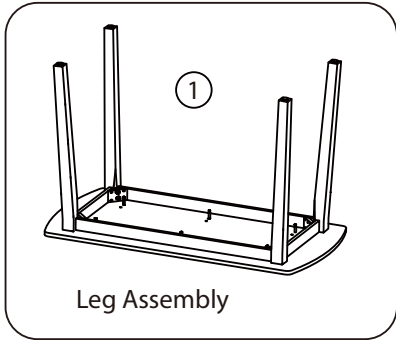

Leg Assembly

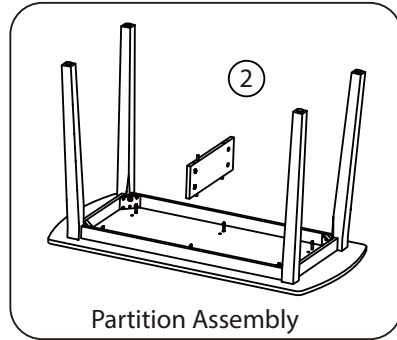

Partition Assembly

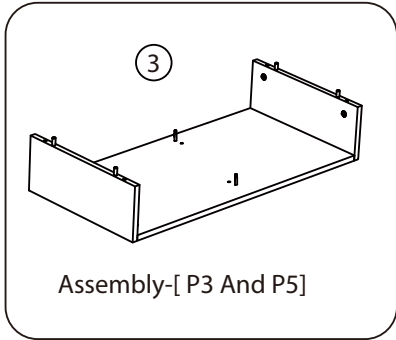

Assembly-[ P3 And P5]

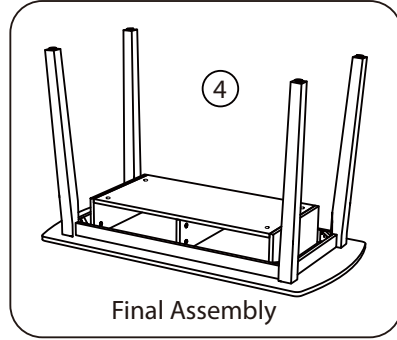

Final Assembly

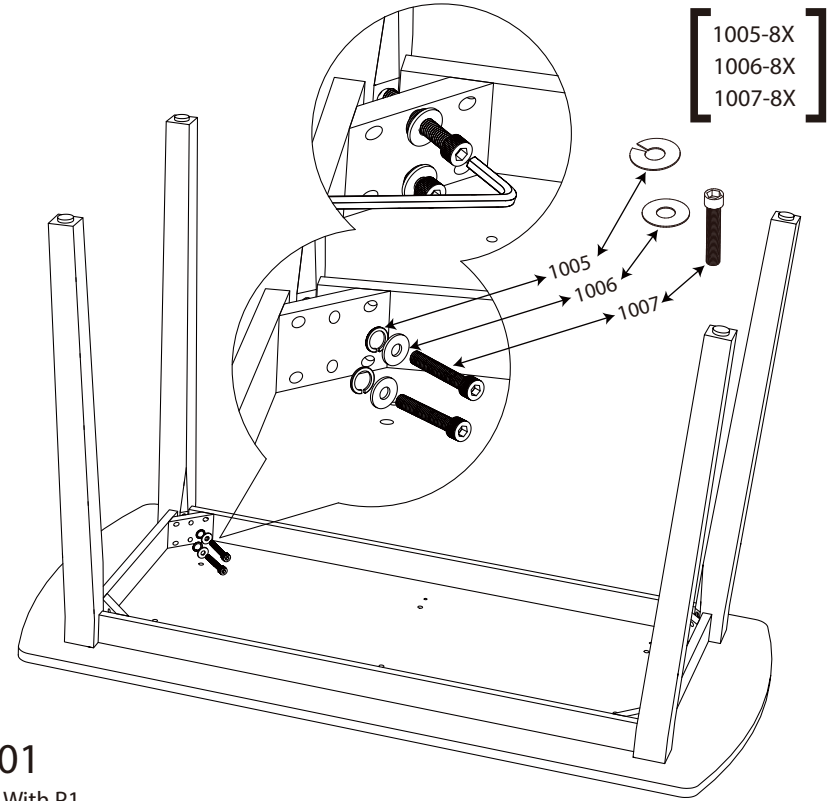

## STEP:01

Attach P2 With P1

[ Note : Fix Other Legs Following this Step ]

