



XOFREC6032_ RETANGULAR GAS FIRE TABLE

PUT SOME AWESOME IN YOUR BACKYARD



XOFREC6032GR



XOFREC6032LS

- 65,000 BTUs
- Glass Fiber Reinforced Cement
- Manual Light Ignition
- Natural Gas (with/LP Conversion Kit Incl.)

MEMORIES - WARMTH - EXPERIENCE

Our Fire Tables and Bowls bring a heightened level of design and elegance to any outdoor space. Handcrafted from durable GFRC, our finishing process ensures each fire centerpiece is a unique creation, a beautiful and functional addition to grace any backyard or patio.

Experience the warmth your XO fire bowl can bring to your next gathering.

WORLD CLASS SERVICE | COMPREHENSIVE WARRANTIES

OUR LASTING COMMITMENT TO YOU

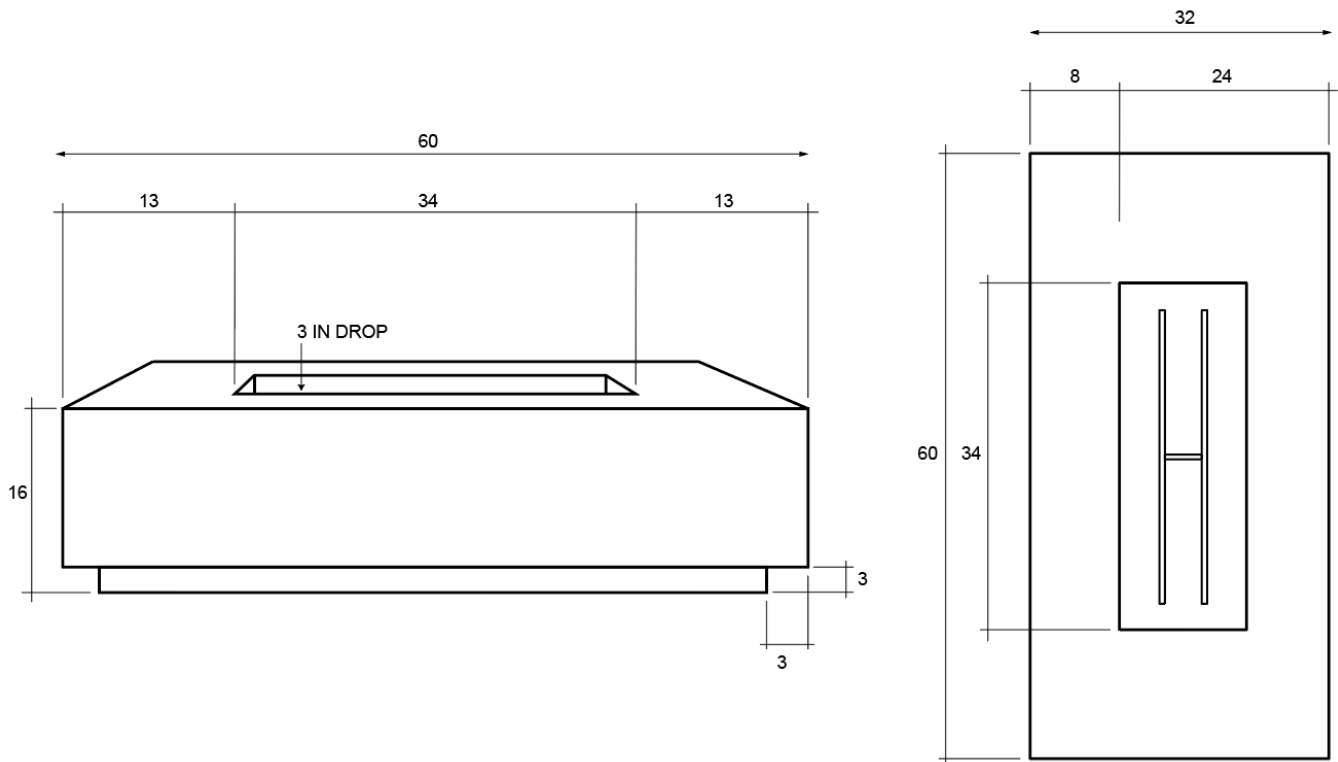

FEATURES

FINISH

Hand Crafted GFRC



Dark Gray



Limestone

FEATURES

- 304 Stainless Steel Burner
- 65,000 BTUs Maximum Output
- Available in Dark Gray or Limestone Finishes
- Individually Hand-Crafted
- Fiberglass Reinforced Durable Concrete
- Lighter than Natural Stone
- Natural Gas Standard (LP Conversion Kit Included)
- Includes 50lbs Lava Rock
- 2 Year Limited Warranty

SPECIFICATIONS

DIMENSIONS 32" W X 60" L X 16" H

BURNER 65,000 BTU

WEIGHT 228 LBS

FUEL SOURCE NG (LP conversion kit included)

IGNITION Manual Light

MATERIALS Glass fiber reinforced cement

OPTIONS

- Round Propane Encl. **XOFRNDENC20GR**
- Square Propane Encl. **XOFSQRENC20GR**
- 50lbs Round Fire Rocks **XOFROCK50LBS**
- 50lbs Lava Fire Rocks **XOFLAVA50LBS**
- Fire Table Cover **XOFCOVERREC60**