

# ASSEMBLY INSTRUCTIONS

---

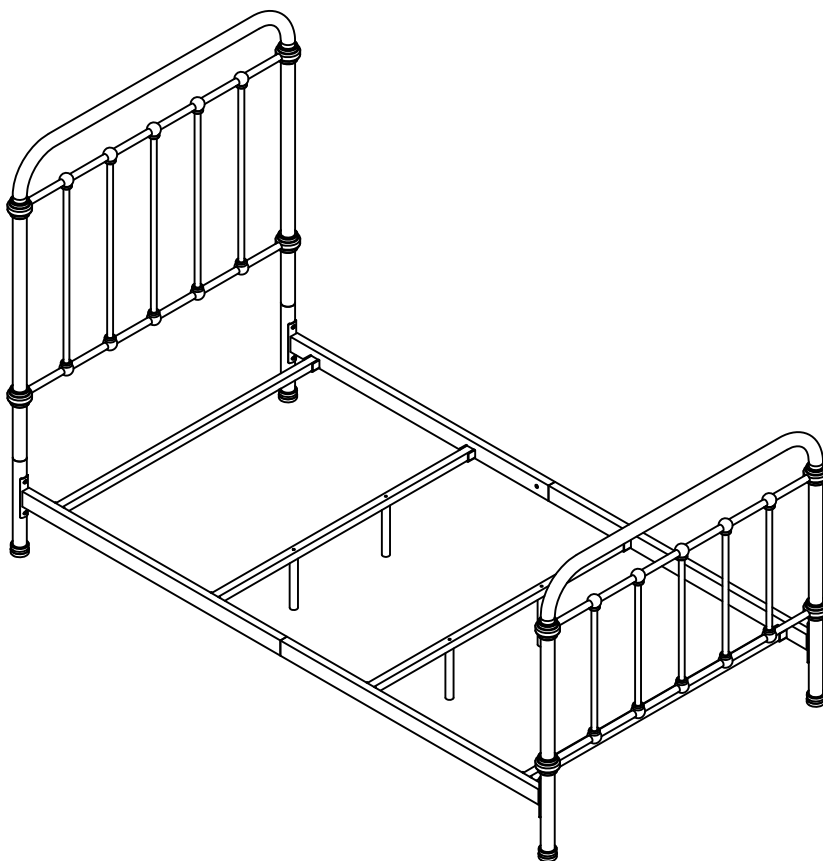

## TOOLS REQUIRED

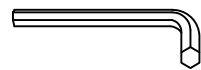

Allen Wrench

(Included)

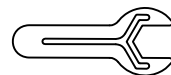

Wrench

(Included)



**3 - People  
Recommended**

## ASSEMBLY RATING

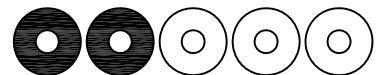

EASY —————> DIFFICULT

The Assembly Rating is a 5-point system showing the level of effort needed to assemble a specific product.



## **CHECK BEFORE STARTING**

- Are you missing anything?**  
Double-check all parts, hardware and accessories listed on Page 6 are accounted for.
- Check out our Quick Tips!**  
We recommend reviewing the pre-assembly handouts. Even experts need a refresher now and then!
- Should we send any replacements?**  
Are there any irregularities or flaws in the parts? We can send replacements!
- Prep Time!**  
Please review the assembly instructions and all diagrams prior to assembling. Arrange parts as recommended on Page 7 and group identical hardware together to make assembling easier.

# PRE ASSEMBLY INTRODUCTION

We understand building ready-to-assemble furniture can be a challenging experience for some. To help avoid confusion, we have provided some helpful tips that may speed up the process.

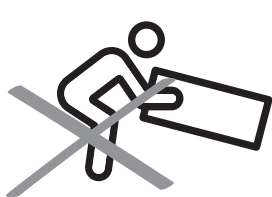

## Teamwork

ALWAYS have at least two people to help with transporting and assembling the product to avoid potential injury and/or damage.

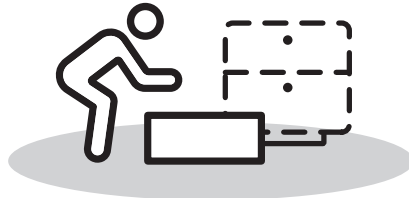
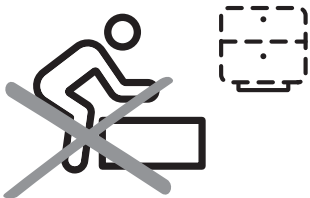

## Suitable Location

Assembling near the area of the intended location is highly recommended.



## Sufficient Space

Make sure you have enough space to move around during the assembly.



## Avoid Scratches

Use cardboard, blankets or a carpeted area while assembling furniture to prevent scratches.

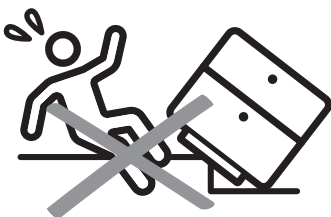

## Flat Surface

Make sure the furniture rests on a flat and level surface with each leg evenly touching the floor.

# ASSEMBLY AND CARE ADVICE



**FAILURE TO FOLLOW THE GUIDELINES BELOW MAY RESULT IN INJURY AND/OR PROPERTY DAMAGE.**



Position each part correctly and insert screws or bolts into their respective holes.



Turn clockwise to tighten and only tighten when step is completed or when instructed to do so.



Use the appropriate hand tools or power tools for assembly. Select steps, such as tightening screws and/or bolts, may require hand tools to avoid causing damage during assembly.



Save the instructions and store any supplied tools for later maintenance.



After two weeks, check and tighten any loose hardware and repeat again every six months thereafter.

**IT IS THE USER'S RESPONSIBILITY TO MAINTAIN THE FURNITURE. THE HARDWARE MAY LOOSEN OVER TIME AND MAY CAUSE THE FURNITURE TO BE WOBBLY AND UNABLE TO SUPPORT ITS INTENDED WEIGHT CAPACITY. THIS MAY LEAD TO COLLAPSE AND MAY CAUSE SERIOUS INJURY.**

# TWIN BED



- Please keep instructions for future reference.
- Check the quantity and irregularity of parts and hardware before you start.

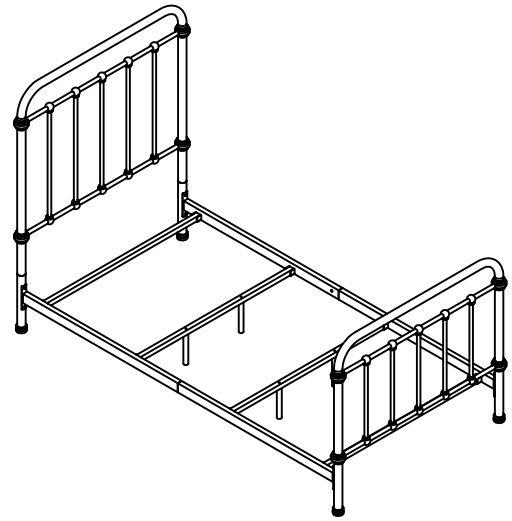

## PARTS

#1 1pc

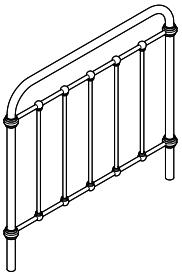

Headboard

#2 1pc

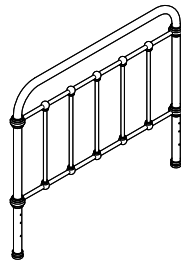

Footboard

#3 2pcs

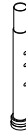

Extension Leg

#4 2pcs

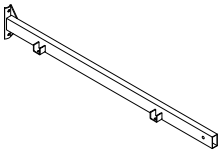

Side Rail

#5 2pcs

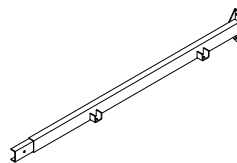

Side Rail

#6 2pcs

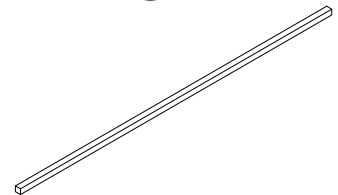

Slats

#7 2pcs

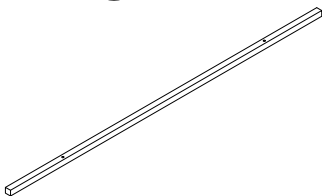

Slats

#8 4pcs



Support Leg

**HARDWARE**

#A 4pcs



Bolt 1/4" x 2"

#B 18pcs



Bolt 1/4" x 5/8"

#C 4pcs



Bolt 1/4" x 7/8"

#D 4pcs



Bolt 1/4" x 1-3/4"

#E 30pcs



Flat Washer  $\phi$ 16mm

#F 4pcs



Nut

#G 1pc



Allen Wrench M4

#H 1pc

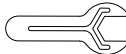

Wrench

# ASSEMBLY INSTRUCTIONS

## 1

- Part #1 x1pc
- Part #3 x2pcs
- Hardware #B x4pcs
- Hardware #E x4pcs
- Hardware #G x1pc

Note:  
Do not fully tighten all bolts until assembly is complete. This will help all parts to assemble properly.

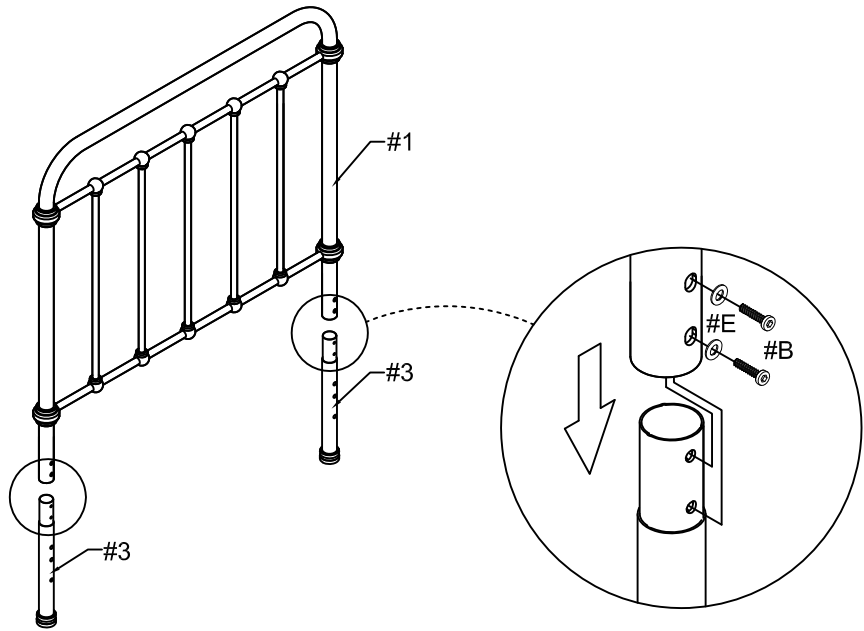

Align HB legs (#3) to the headboard (#1), then secure by using bolts (#B) with washers (#E).

## 2

- Part #4 x2pcs
- Part #5 x2pcs
- Hardware #B x6pcs
- Hardware #E x6pcs
- Hardware #G x1pc

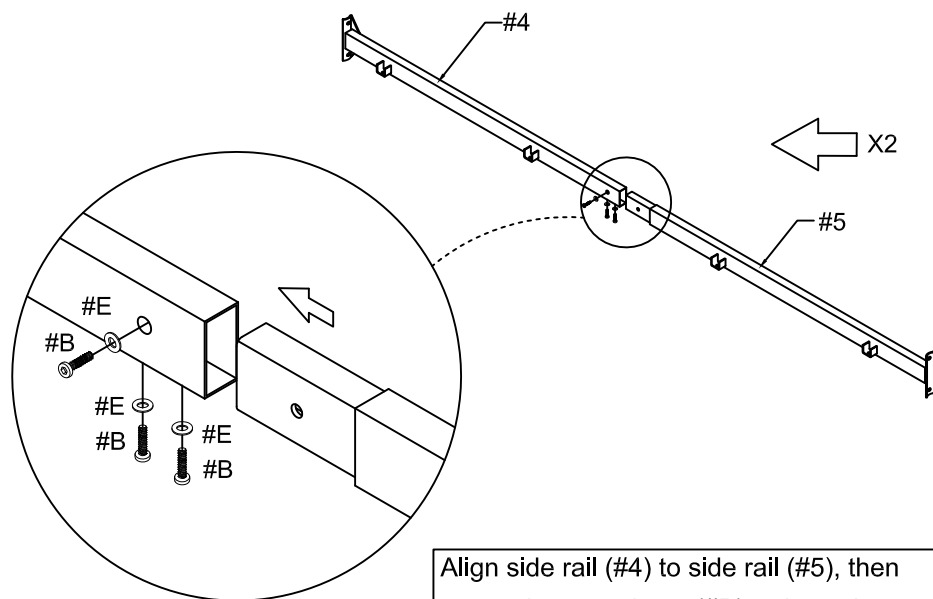

Align side rail (#4) to side rail (#5), then secure by using bolts (#B) with washers (#E).

# ASSEMBLY INSTRUCTIONS

## 3

- Part #4 x2pcs
- Part #5 x2pcs
- Hardware #A x4pcs
- Hardware #C x4pcs
- Hardware #E x8pcs
- Hardware #F x4pcs
- Hardware #G x1pc
- Hardware #H x1pc

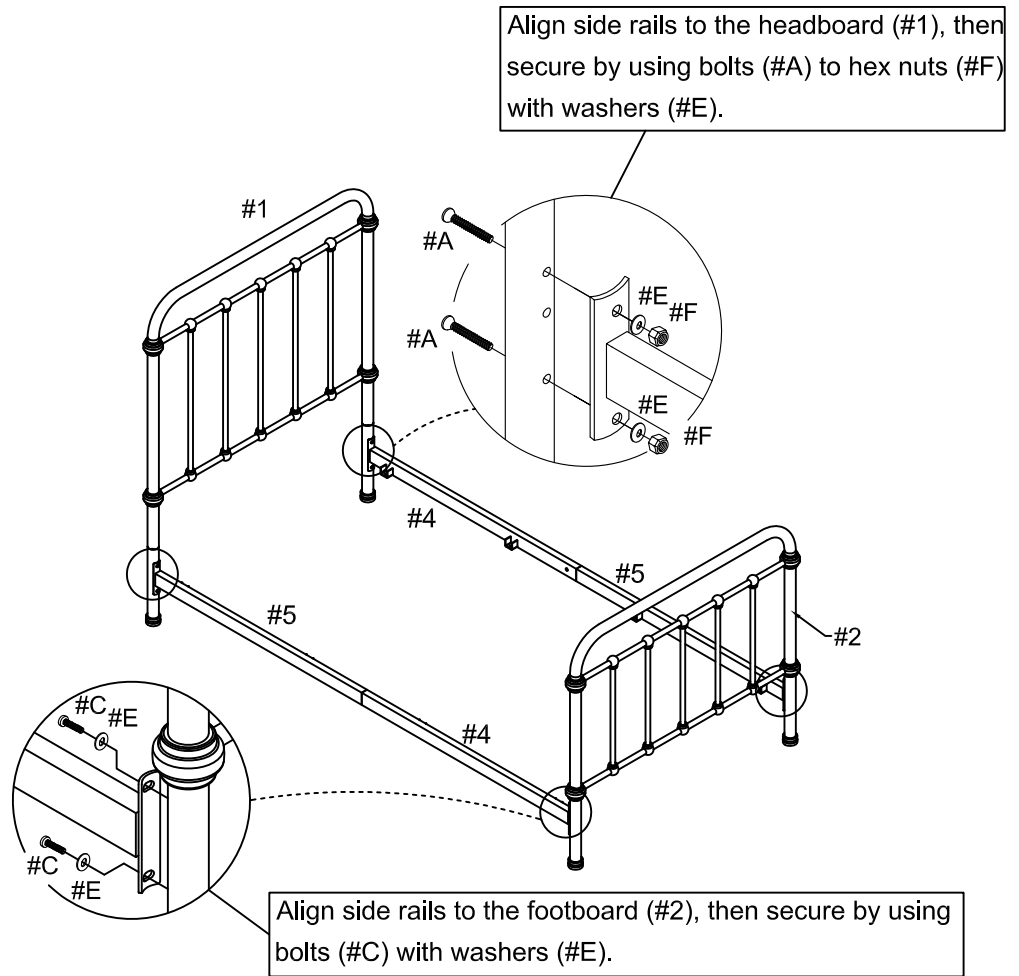

## 4

- Part #7 x2pcs
- Part #8 x4pcs
- Hardware #D x4pcs
- Hardware #E x4pcs
- Hardware #G x1pc

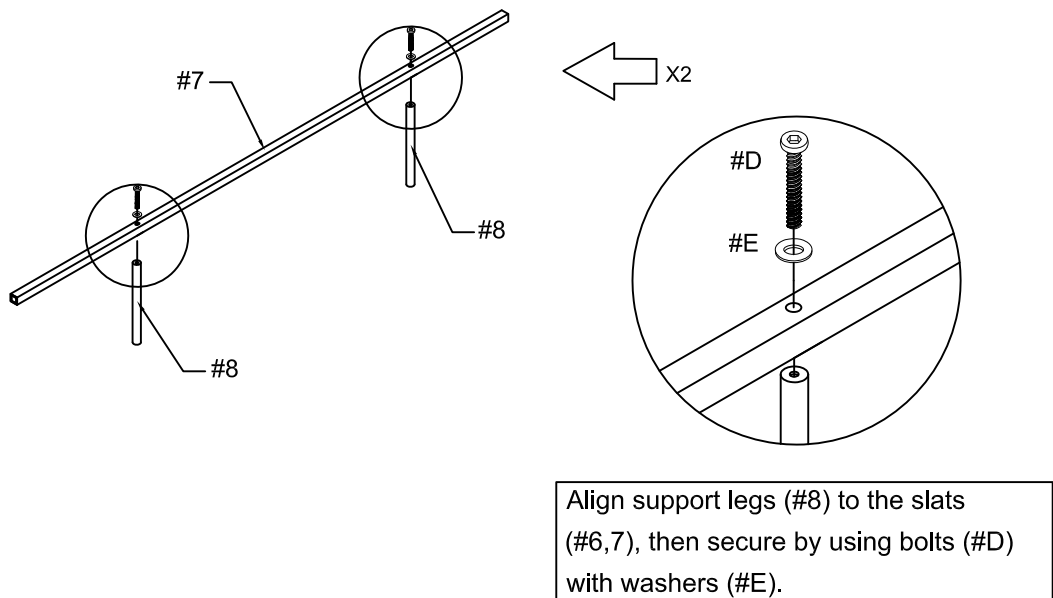

# ASSEMBLY INSTRUCTIONS

Align slats to side rails, then secure by using bolts (#B) with washers (#E).

## 5

Part #6 x2pcs

Part #7 x2pcs

Hardware #B x8pcs

Hardware #E x8pcs

Hardware #G x1pc

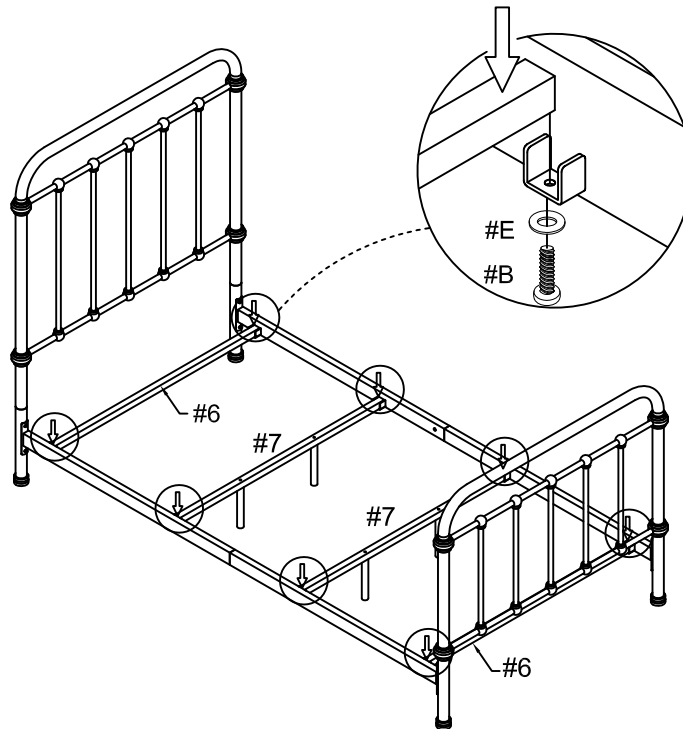

## 6

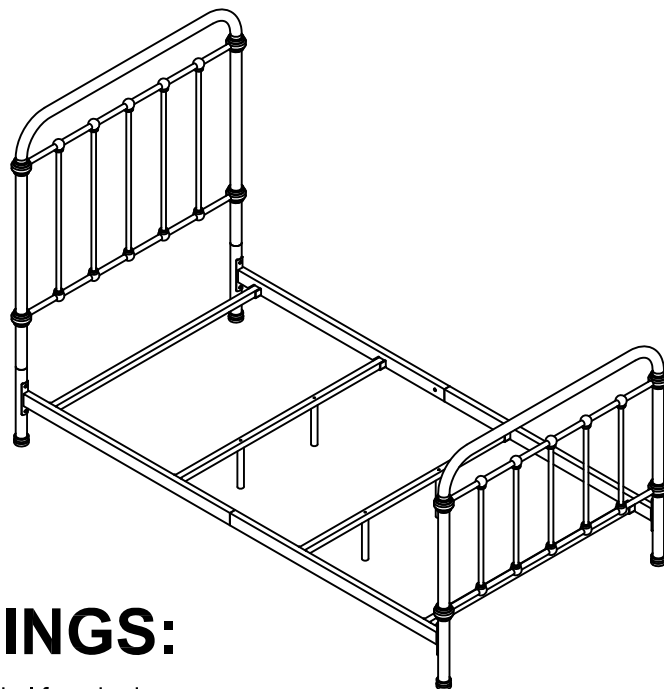

## WARNINGS:

- Do not remove warning label from bed.
- Use only mattress which is 74"-75" long and 37 $\frac{1}{2}$ " - 38 $\frac{1}{2}$ " wide.
- Do not allow horseplay or under the bed and prohibit jumping on the bed.
- Periodically check and ensure that all the components are in their proper position, free from damage, and that all connectors are tight.
- Do not use substitute parts. Contact the store for replacement part.
- Maximum total weight is not to exceed 400 lbs.
- **Keep these instructions for future reference.**

## ASSEMBLY COMPLETED



Please ensure the furniture rests on an even and flat surface. If the product wobbles or feels loose, double-check all bolts and/or screws are properly tightened and secured.



### Keep this handy!

Please retain this instruction manual and any order-related information for future reference.



### Lift, don't drag!

To avoid damage to product please always LIFT the product when transporting or adjusting the placement.