

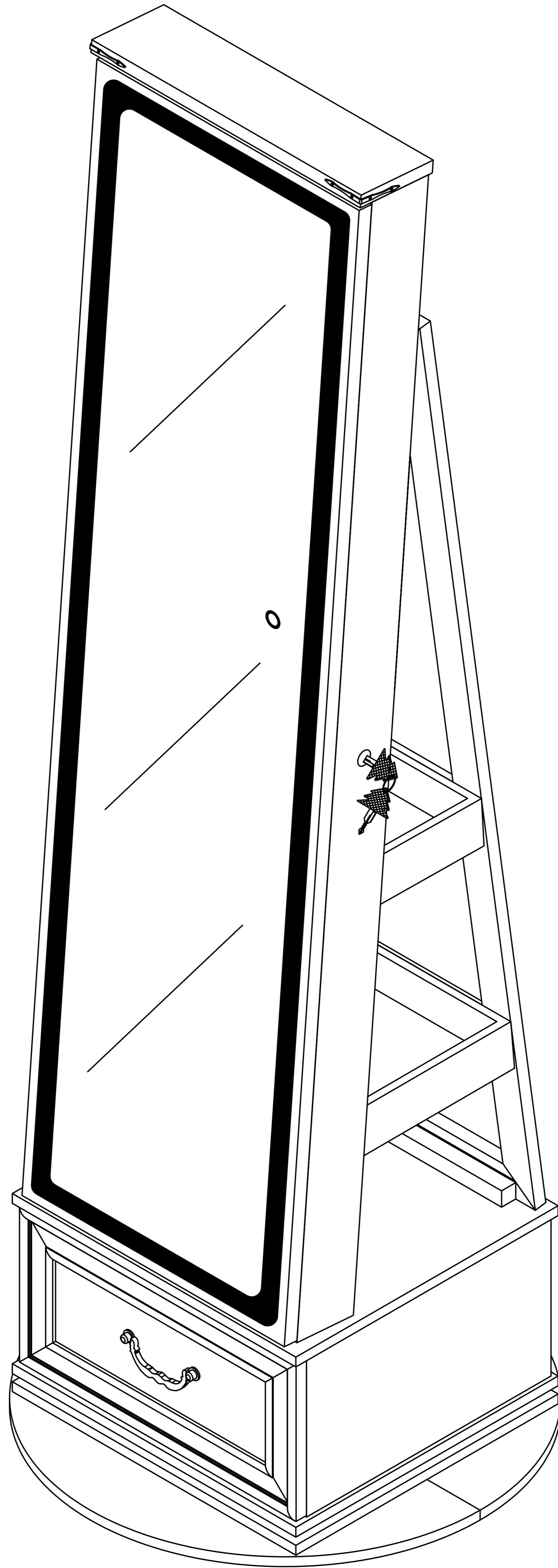

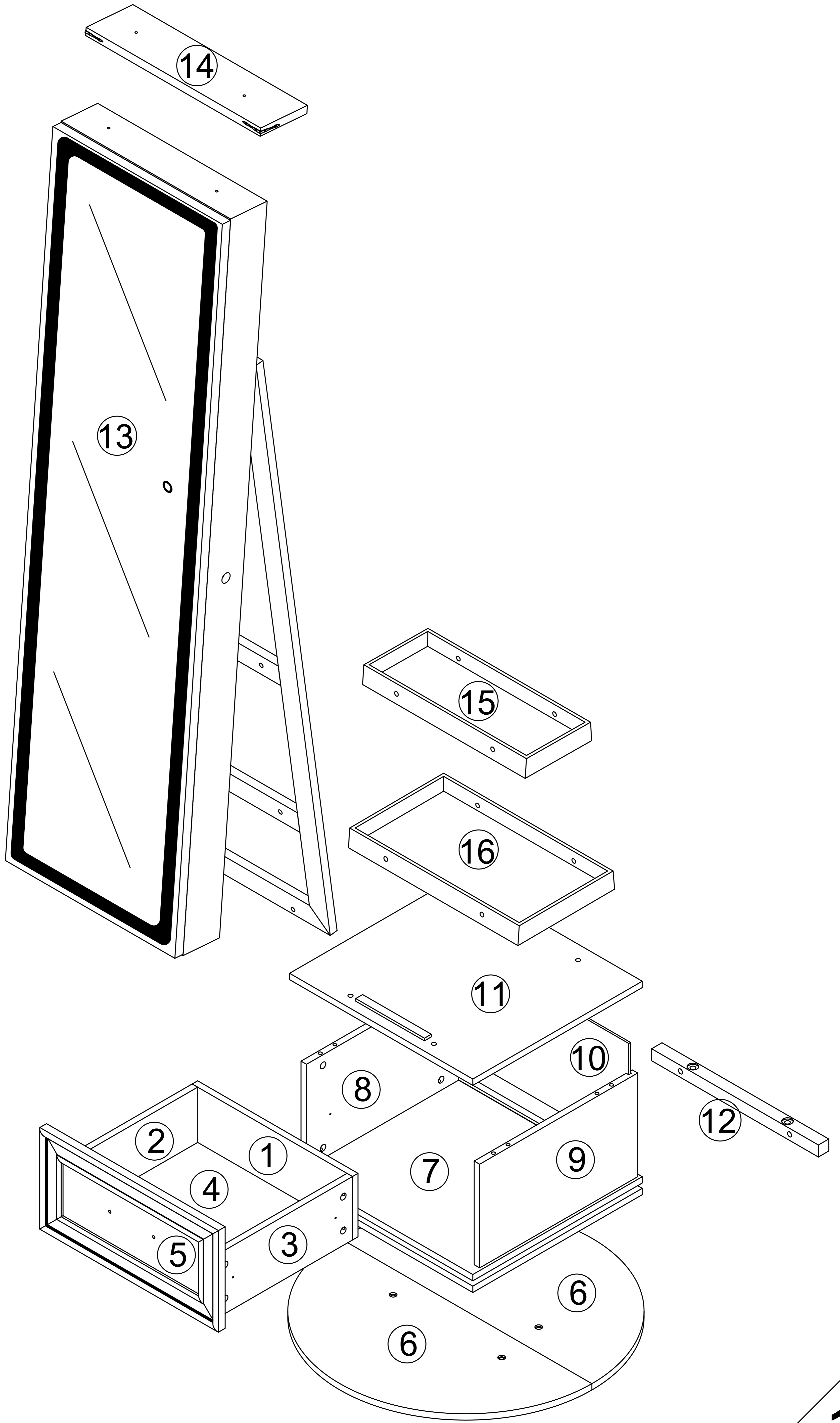

# 67029 MIRROR JEWELLERY CABINET

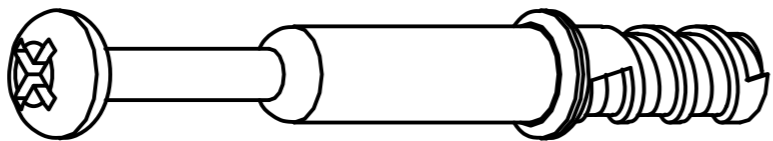

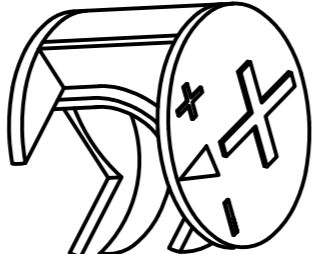
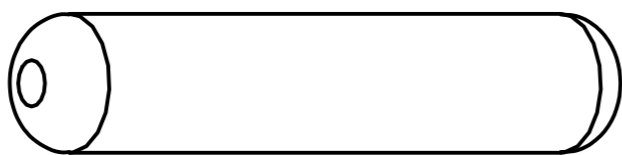
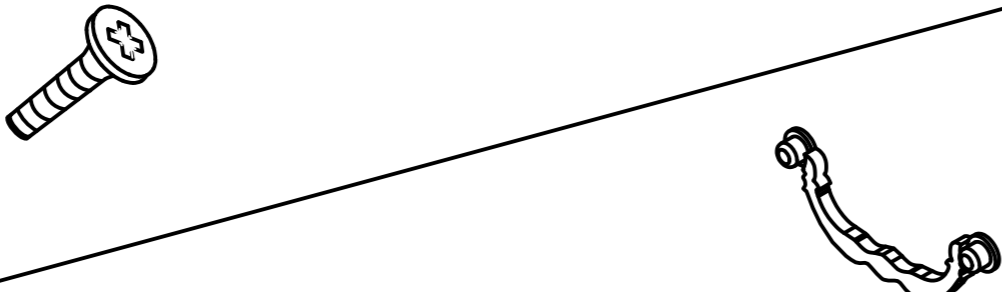
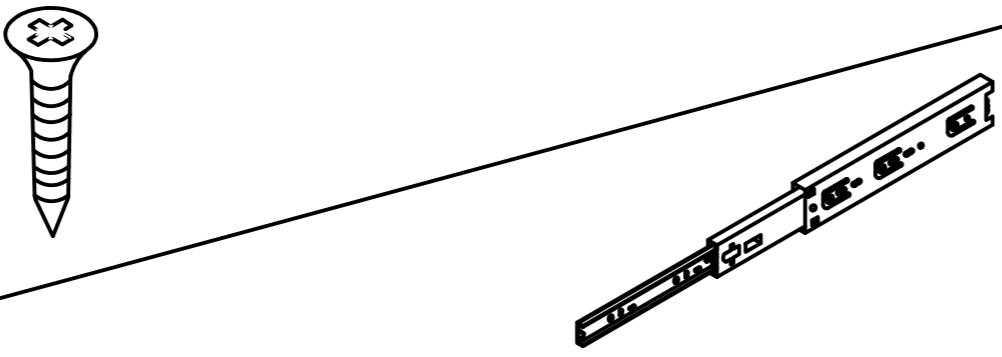
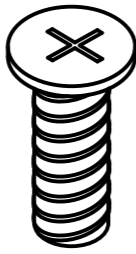

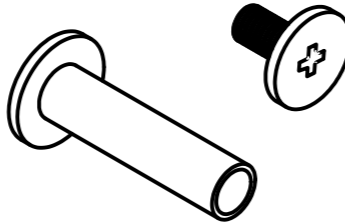
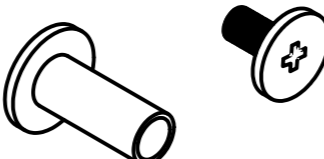
# Accessories list

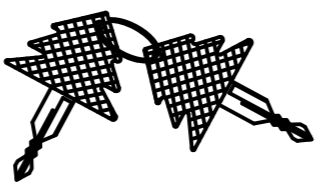
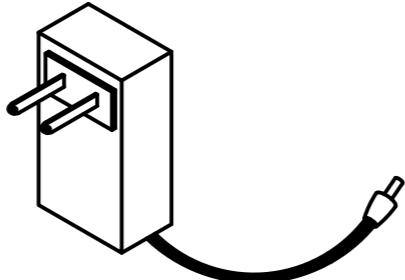
A		Two In One Screw (6x28mm)	16pcs +2pcs
B		Two In One Nut (10x12mm)	16pcs +2pcs
C		Wood Chipping (6x30mm)	8pcs +2pcs
D		Screw & Handle (4x16mm)	2pcs  1pcs
E		Screw & Guide (3x12mm)	10pcs +2pcs  2pcs
F		Screw (6x22mm)	4pcs +1pcs
G		Screw (6x30mm)	6pcs +1pcs
H		Screw (3.5x20mm)	2pcs
I		Pair the lock screws (5x20mm)	4pcs +1pcs
J		Pair the lock screws (5x10mm)	4pcs +1pcs
K	<p style="text-align: center;">Anti tipping hardware</p>  <p style="text-align: center;"> <span>x1</span>      <span>x1</span> (3.5x12mm)      <span>x2</span>      <span>x1</span> (4x45mm)      <span>x1</span> </p>		
L		The key	1pcs
M		The power adapter (12V 3A)	1pcs

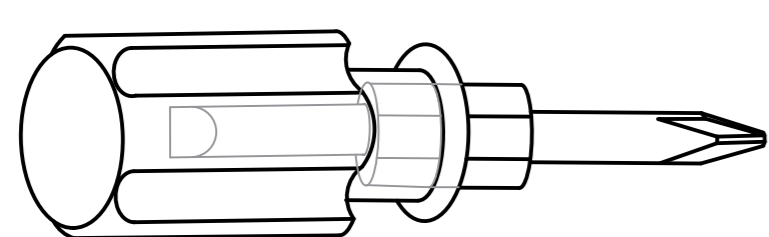

1pcs

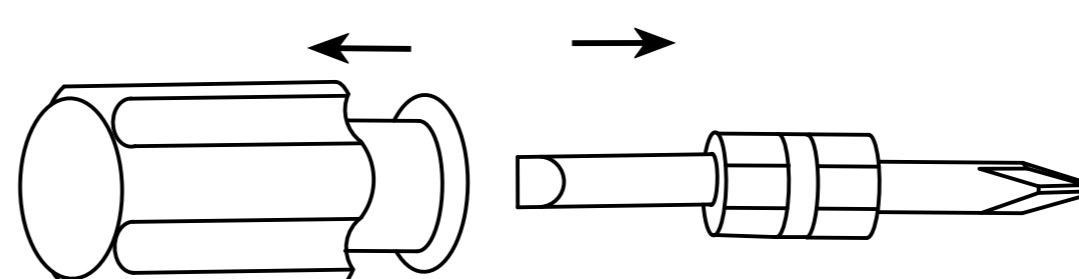

Double-head screwdriver, use as required

2

# Use parts A and B

Step 1

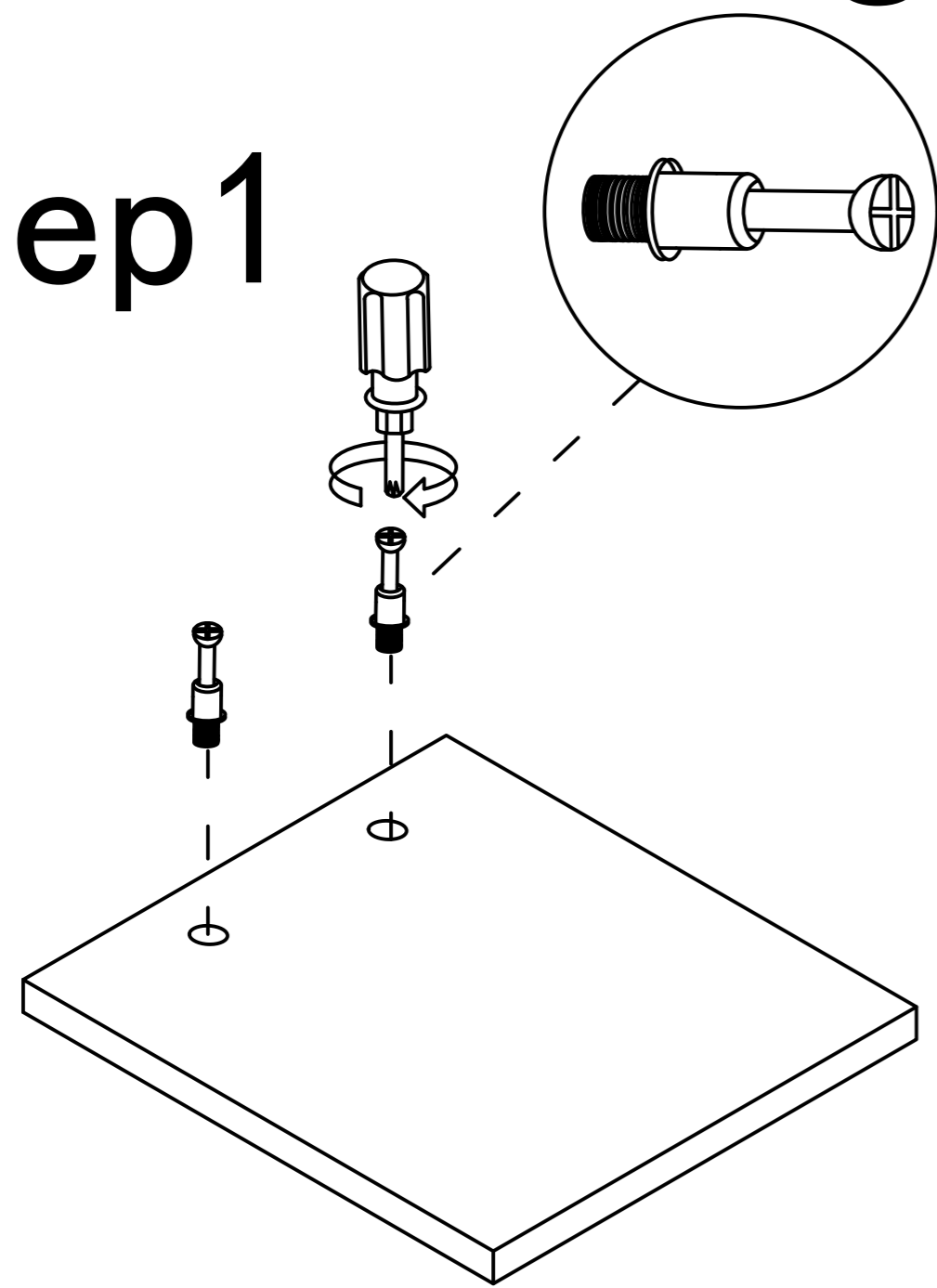

Step 2

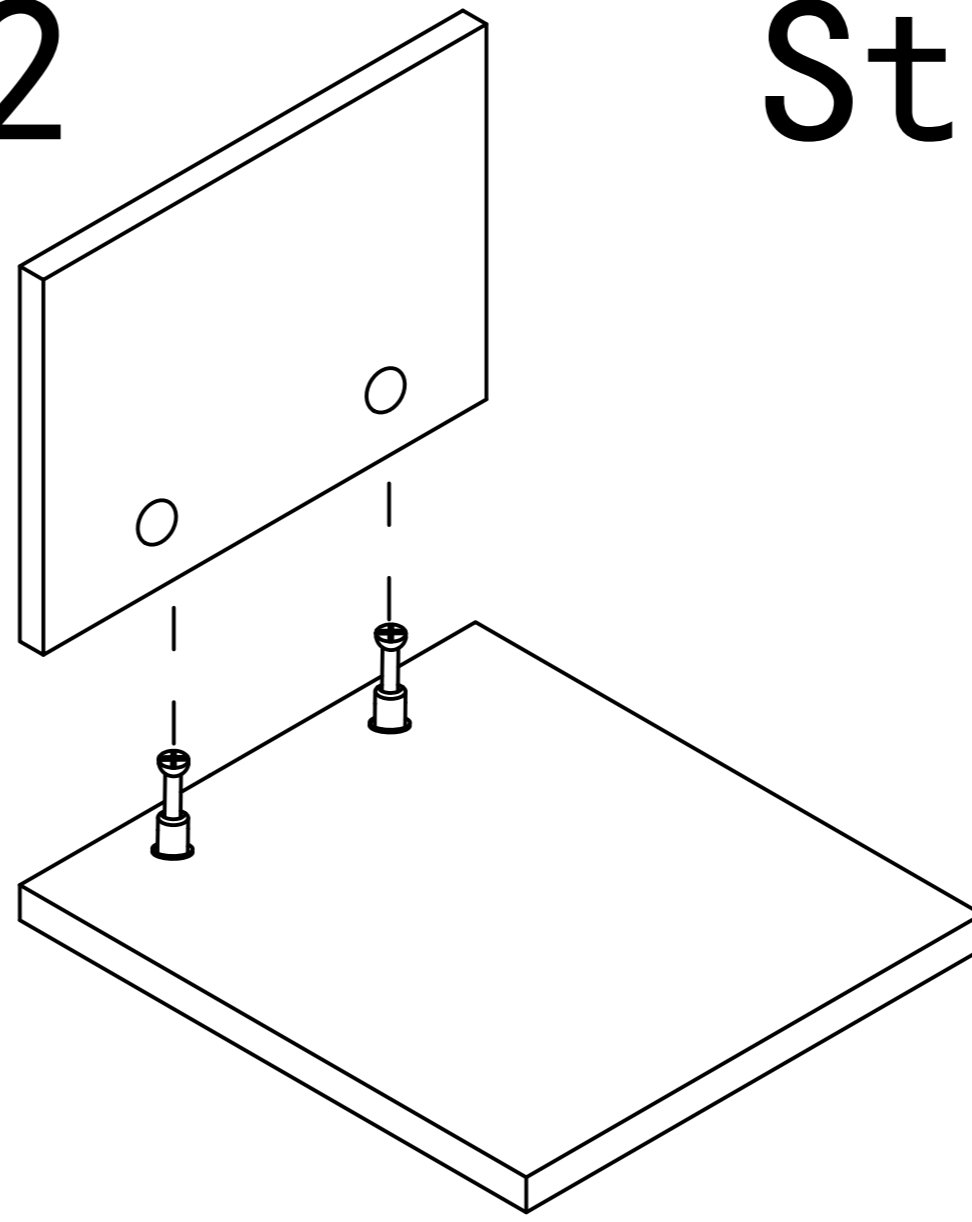

Step 3

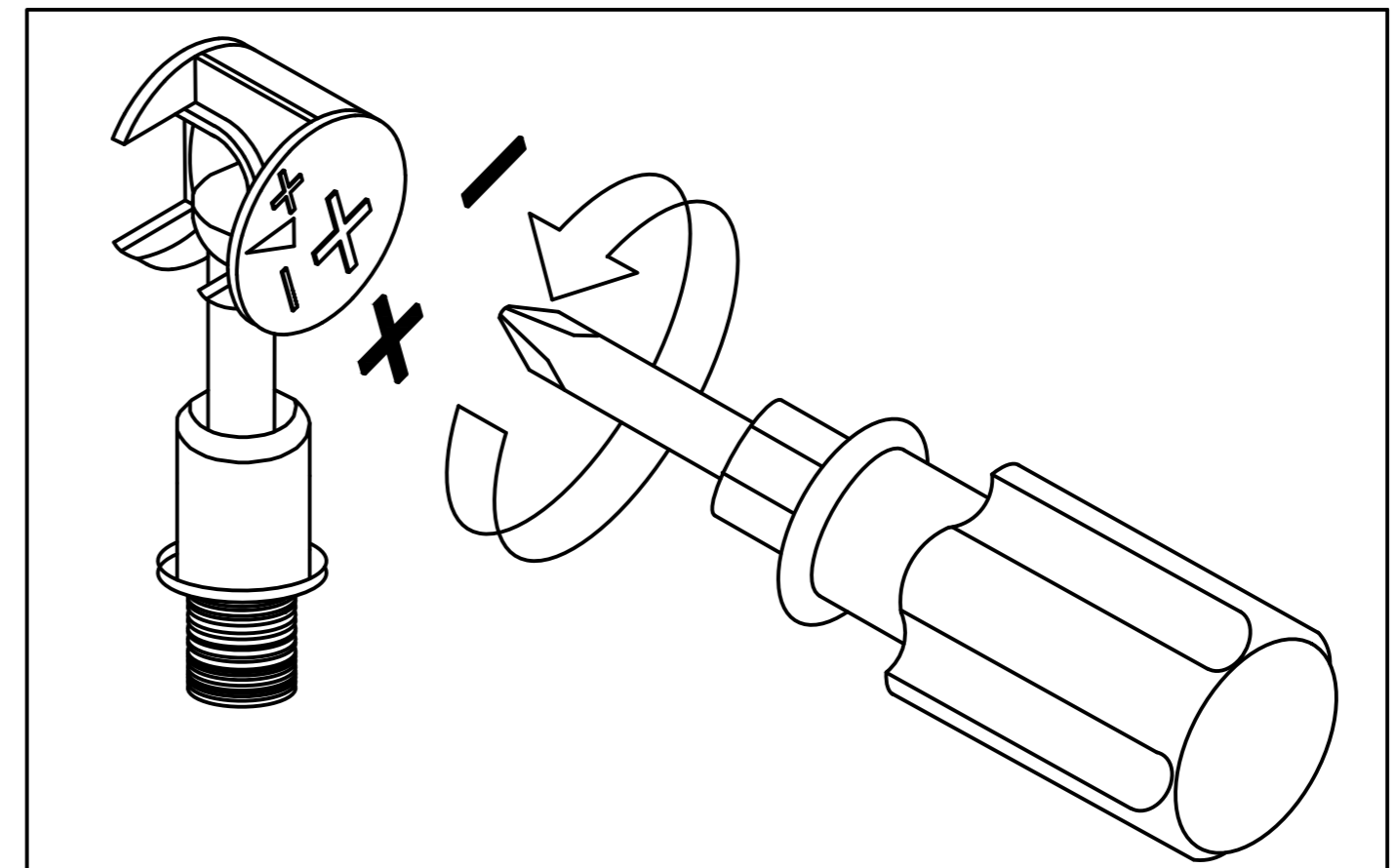
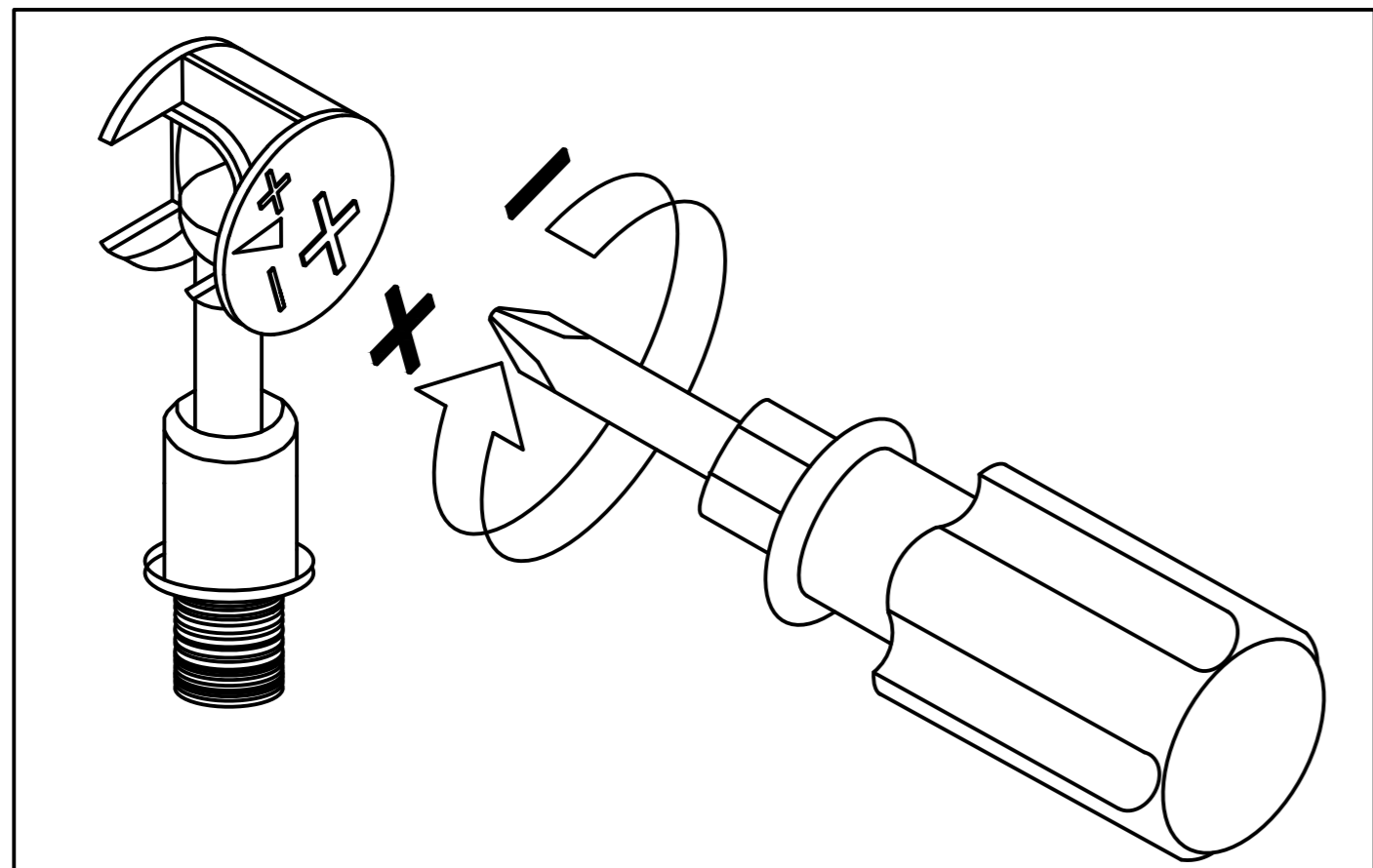
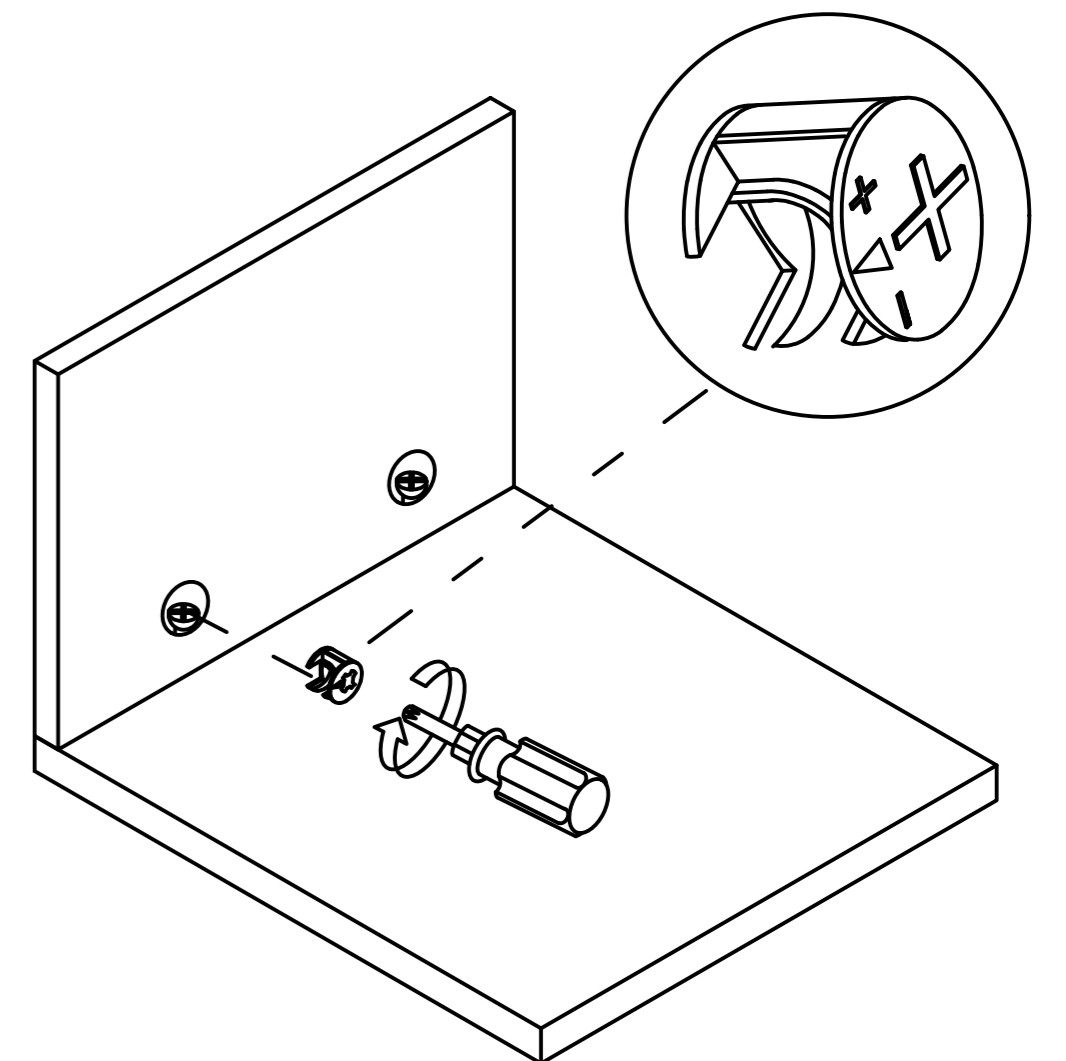

Use a screwdriver to lock in the direction of the "+" sign

Disassemble along the direction of "-" sign

Step 1

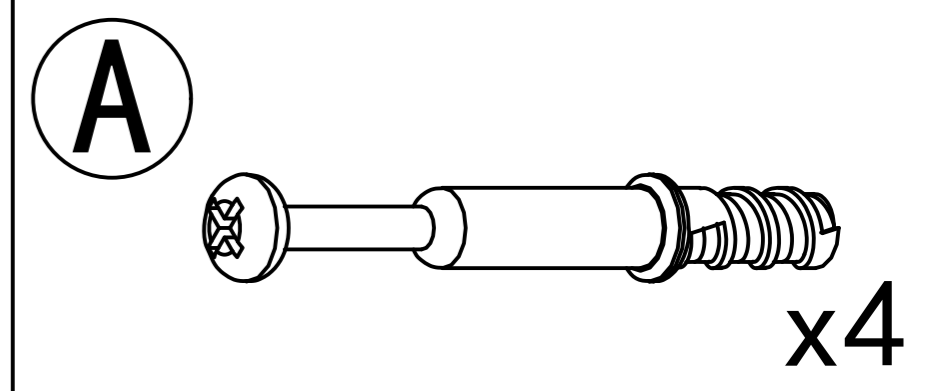
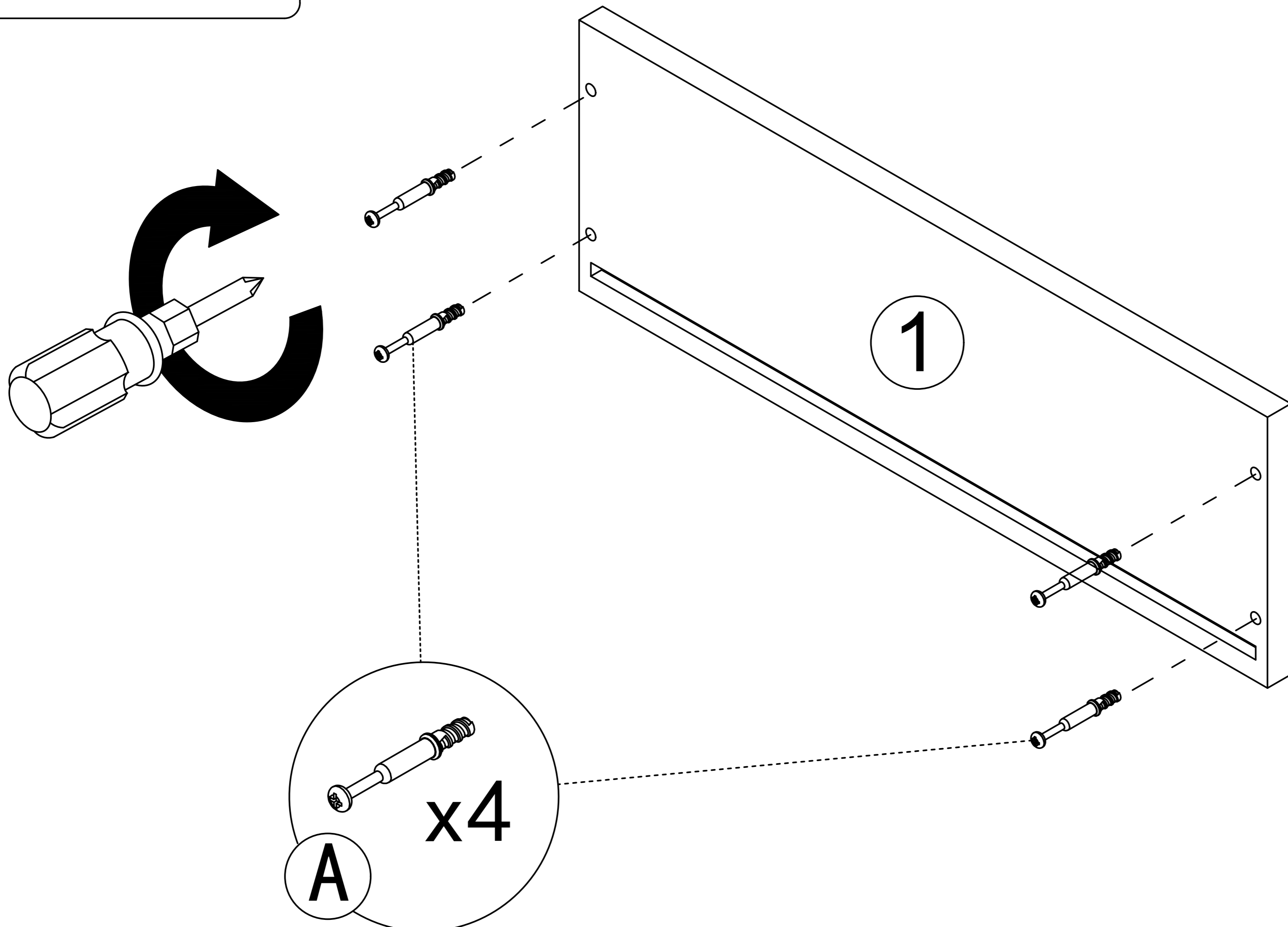

3

# Step 2

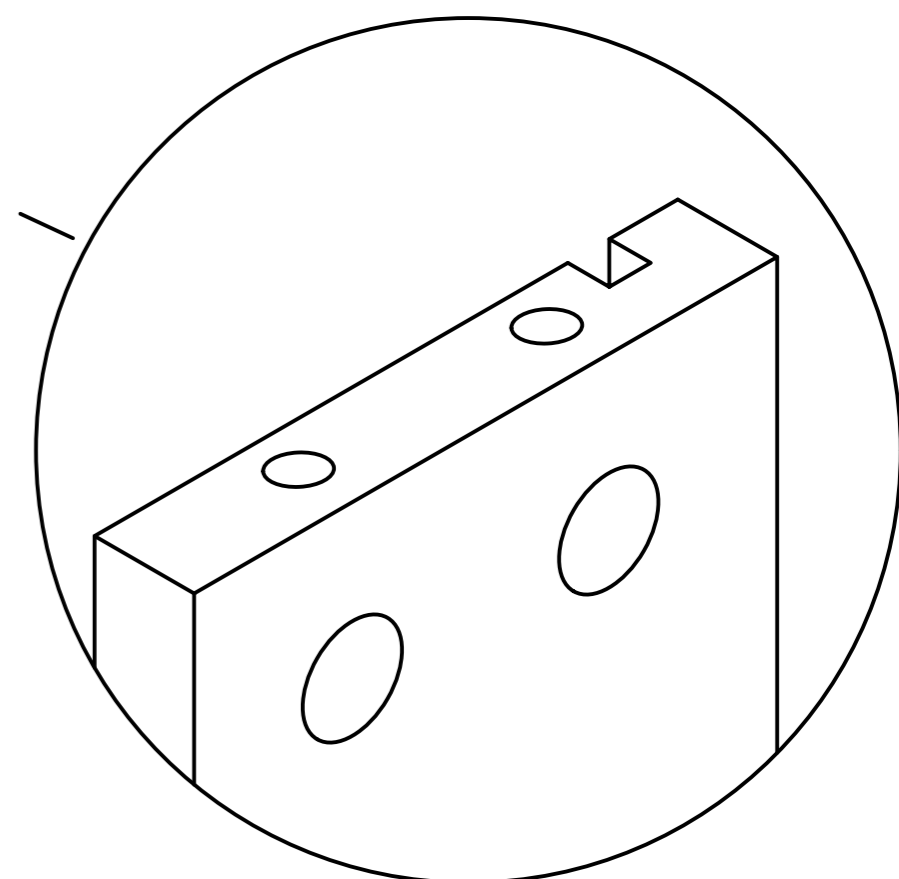
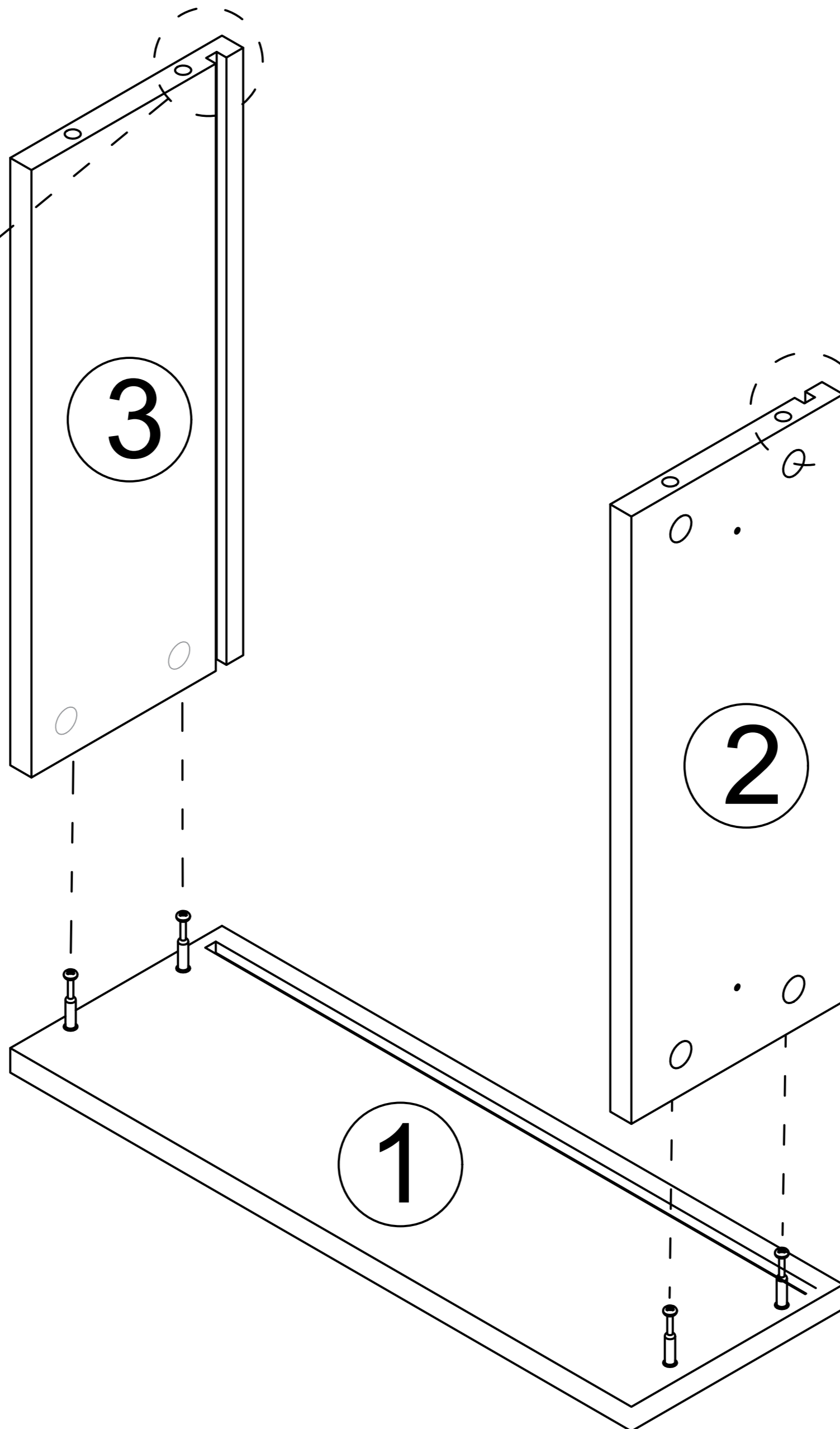
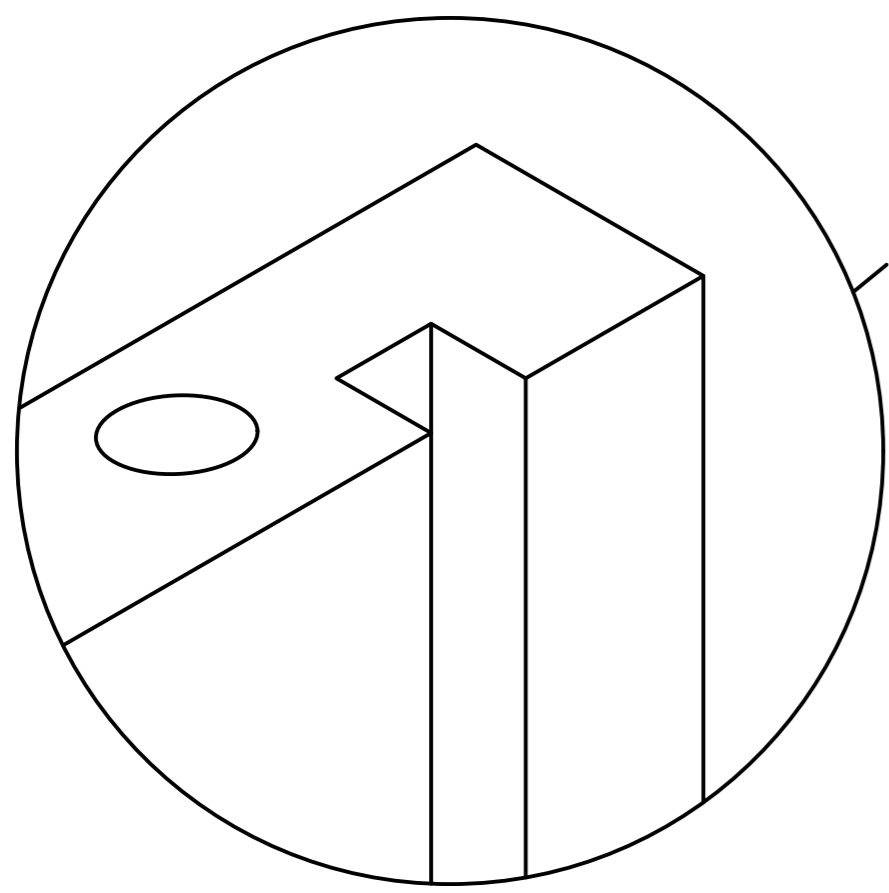

# Step 3

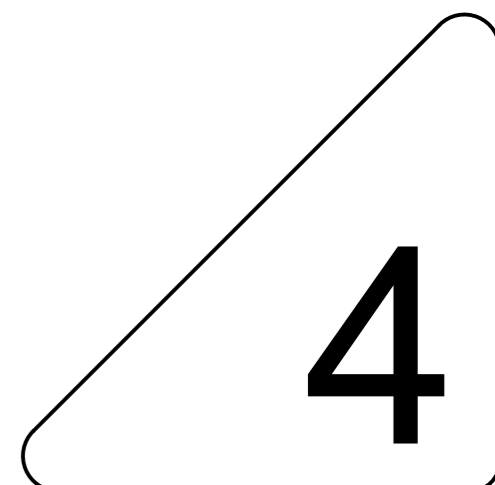
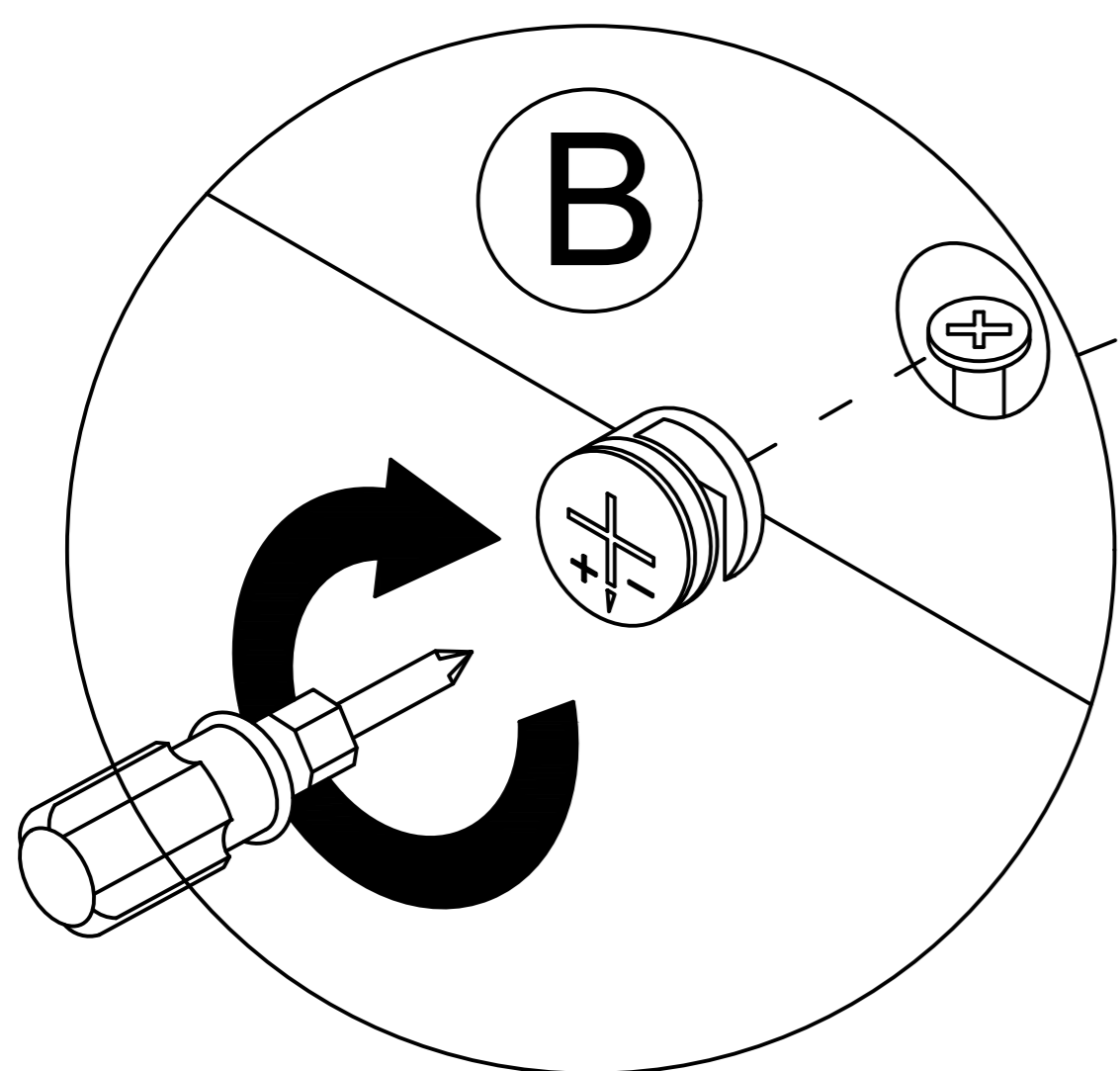
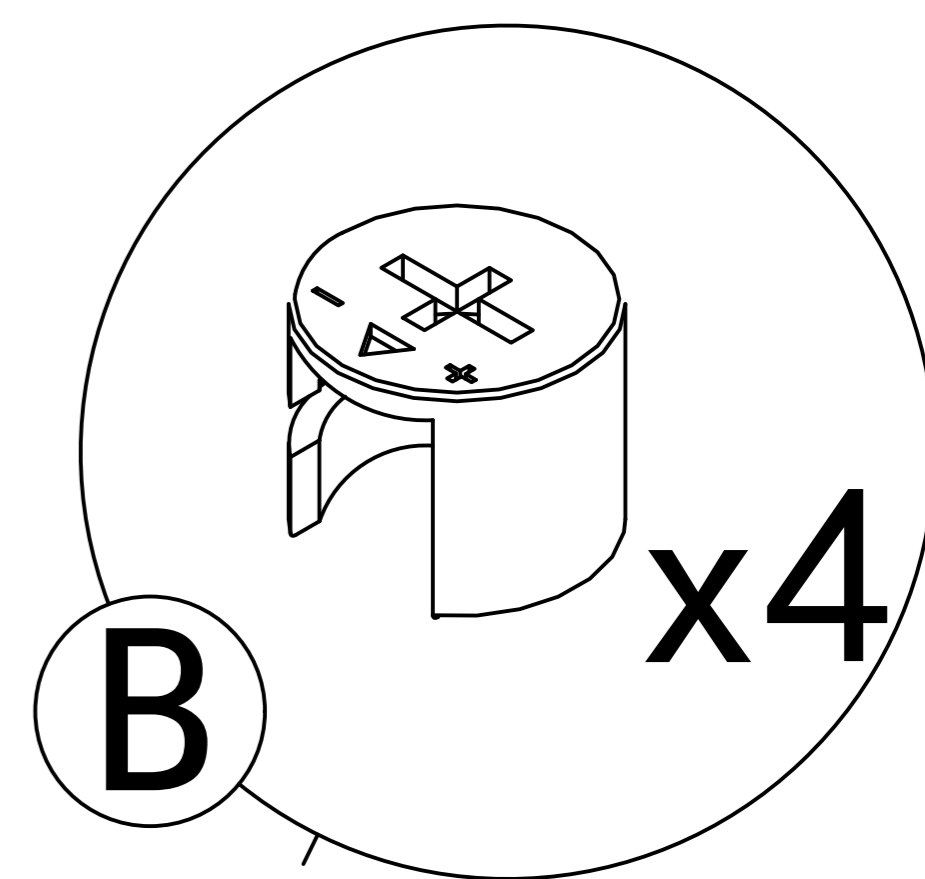
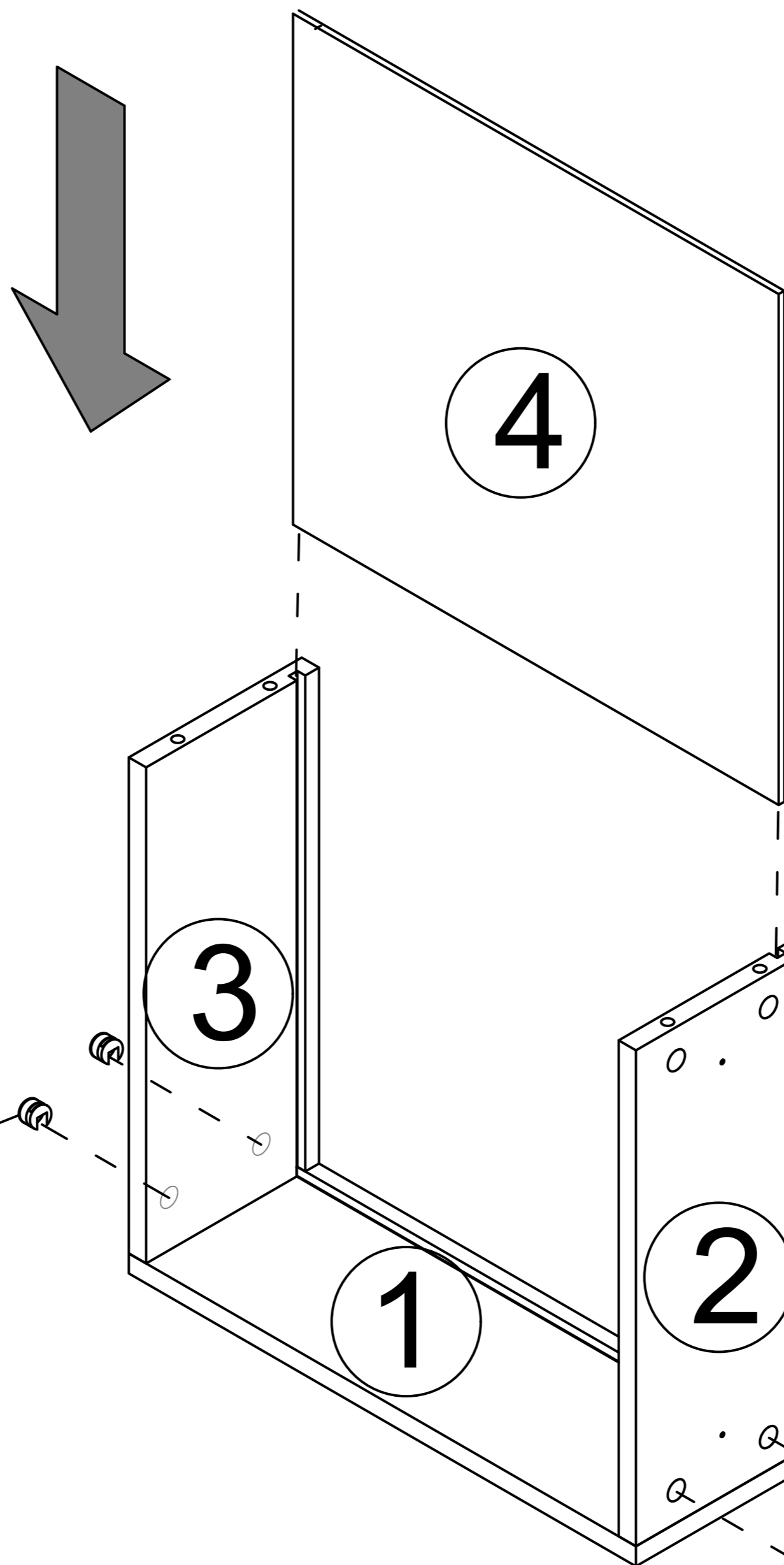
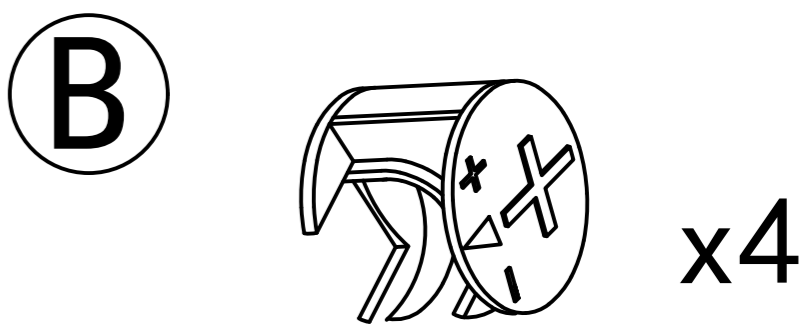

Step 4

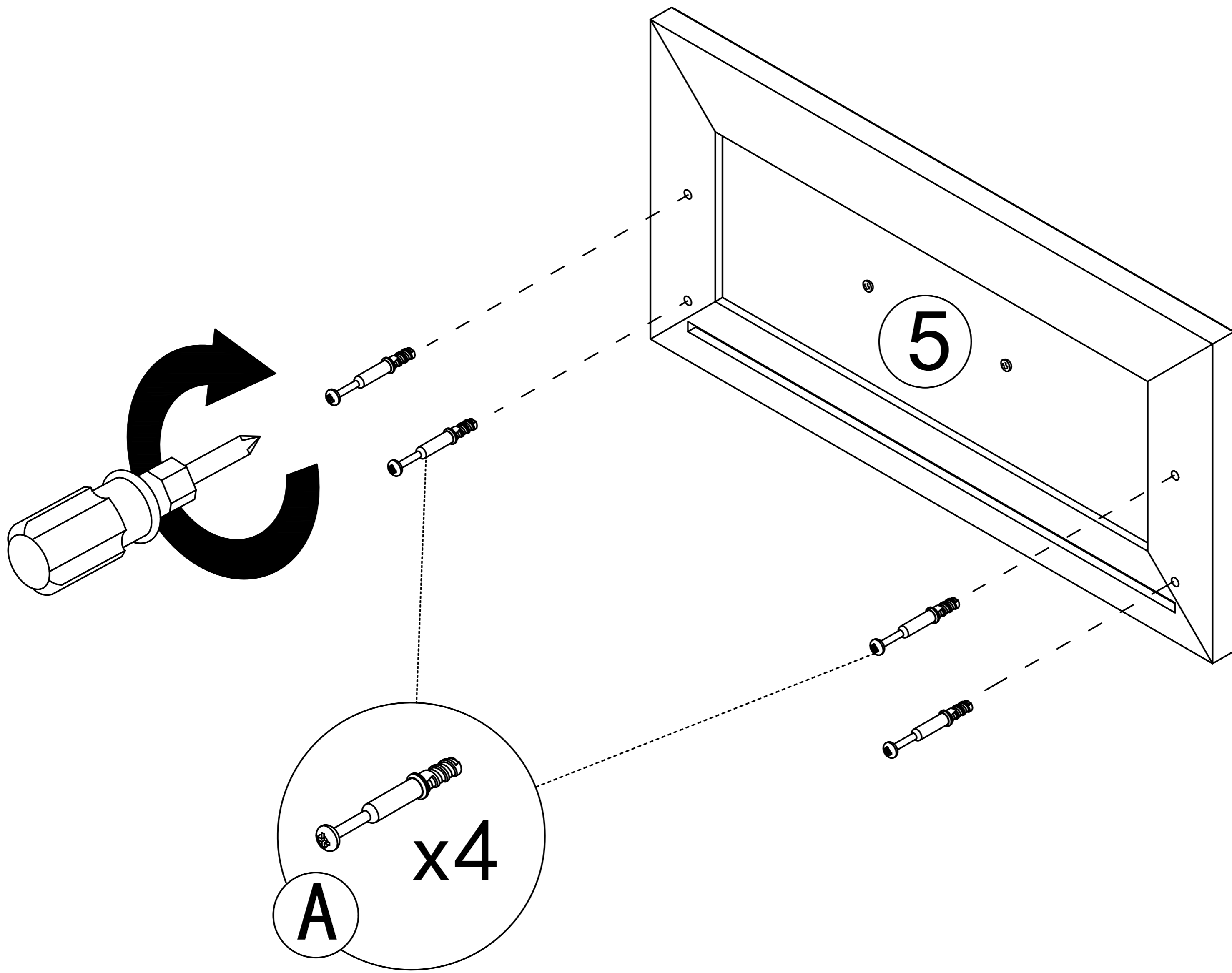
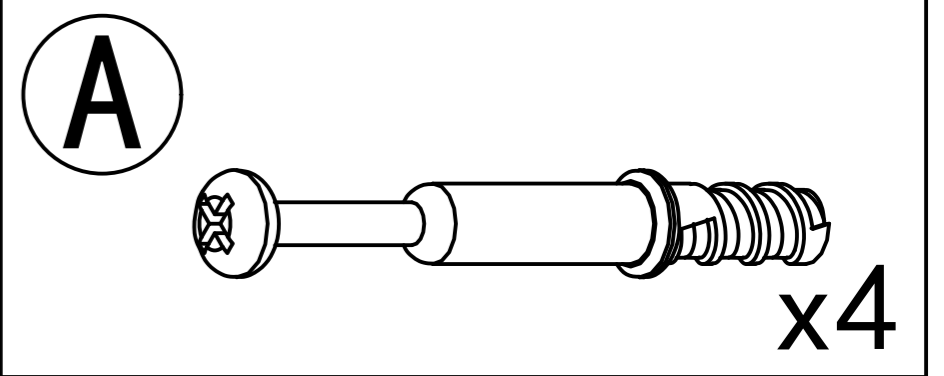

Step 5

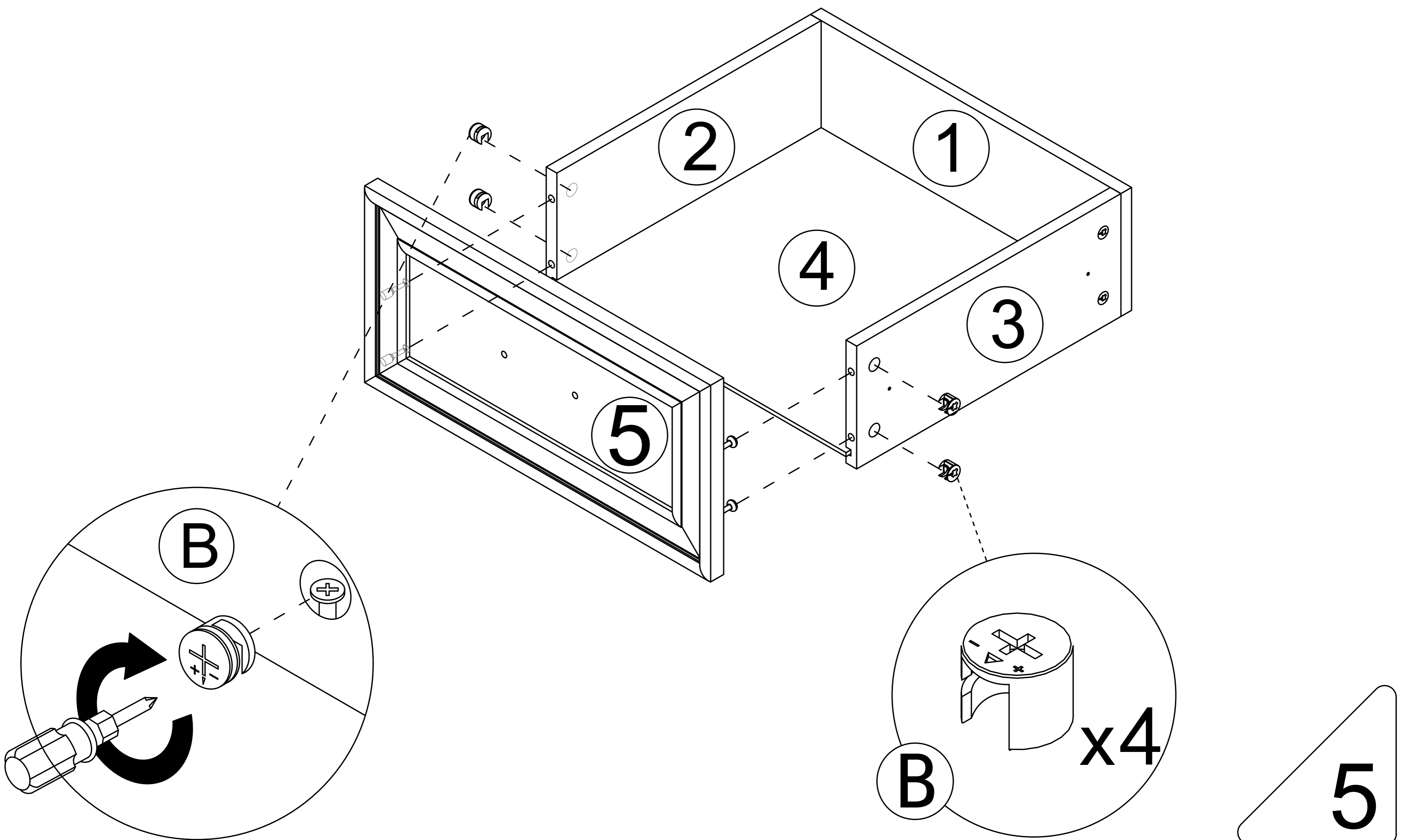
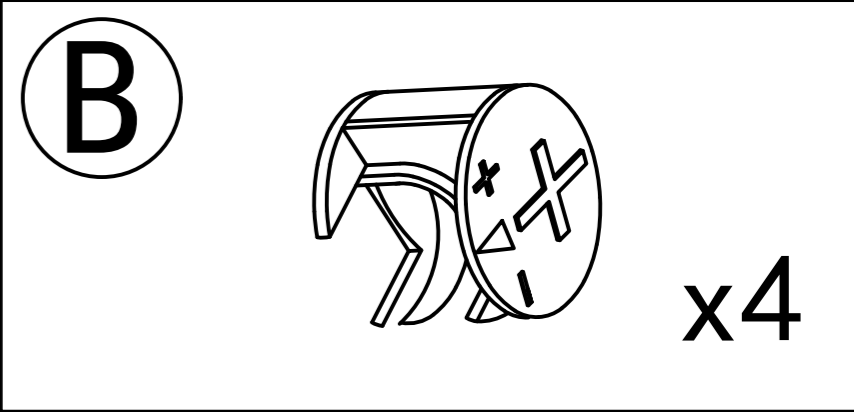

# Use parts (E)

Drawer rail breakdown diagram

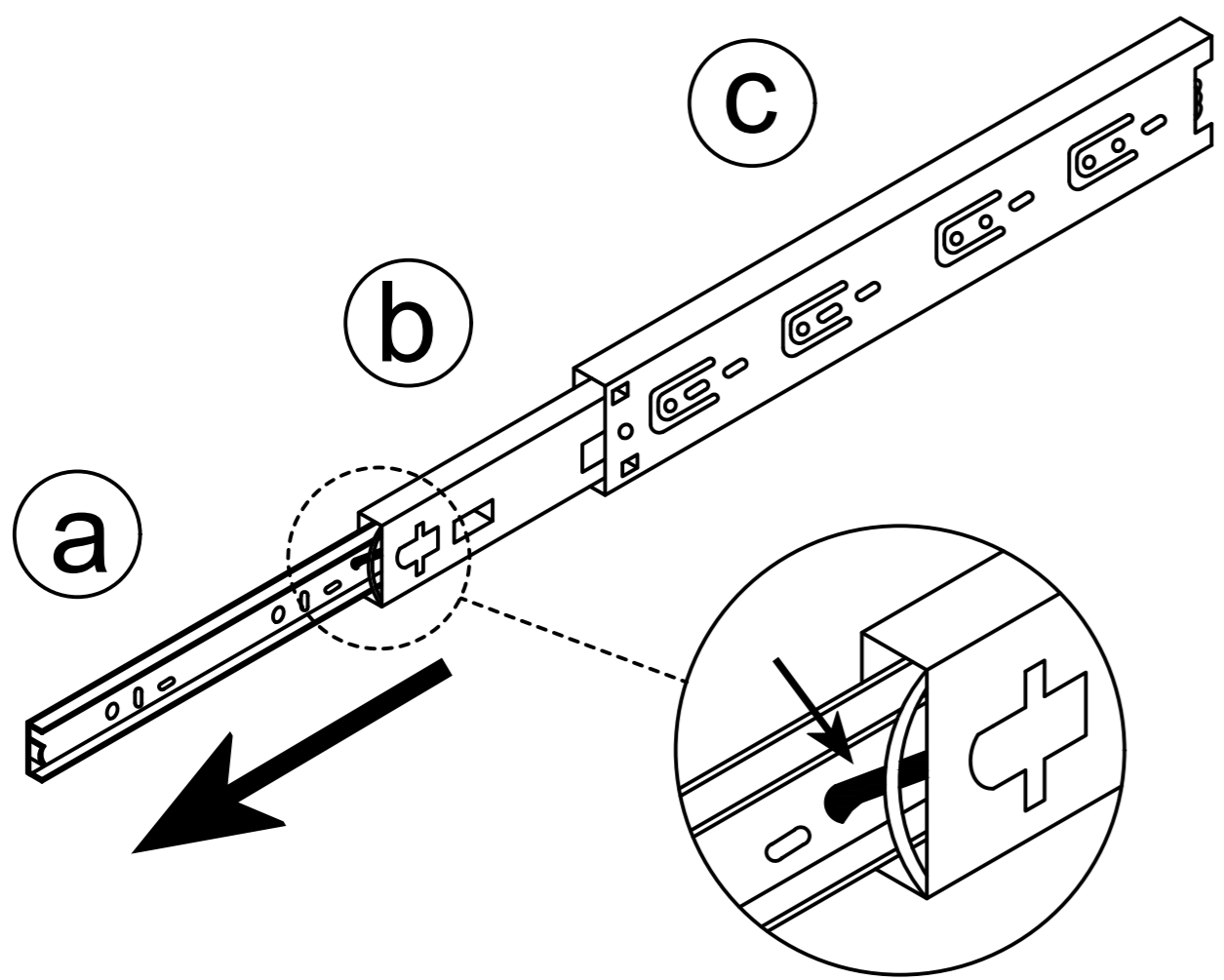

Step 1 : Pull the rails apart

Step 2 : Push the nylon buckle outward (a)

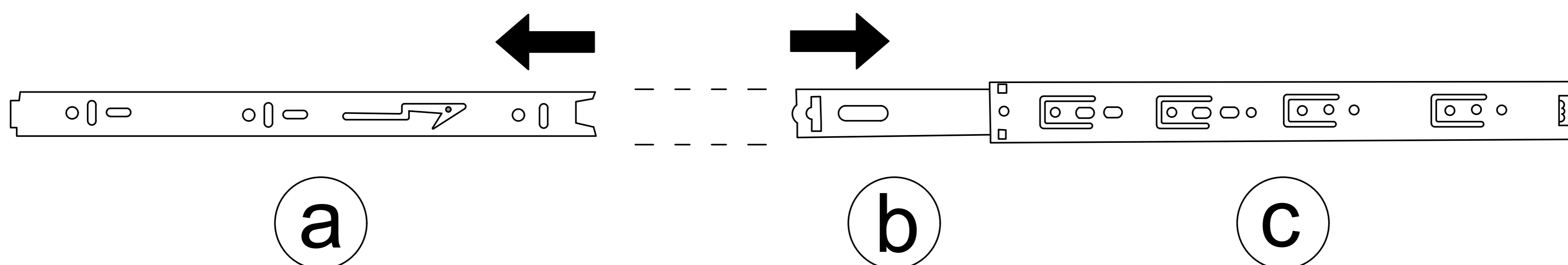
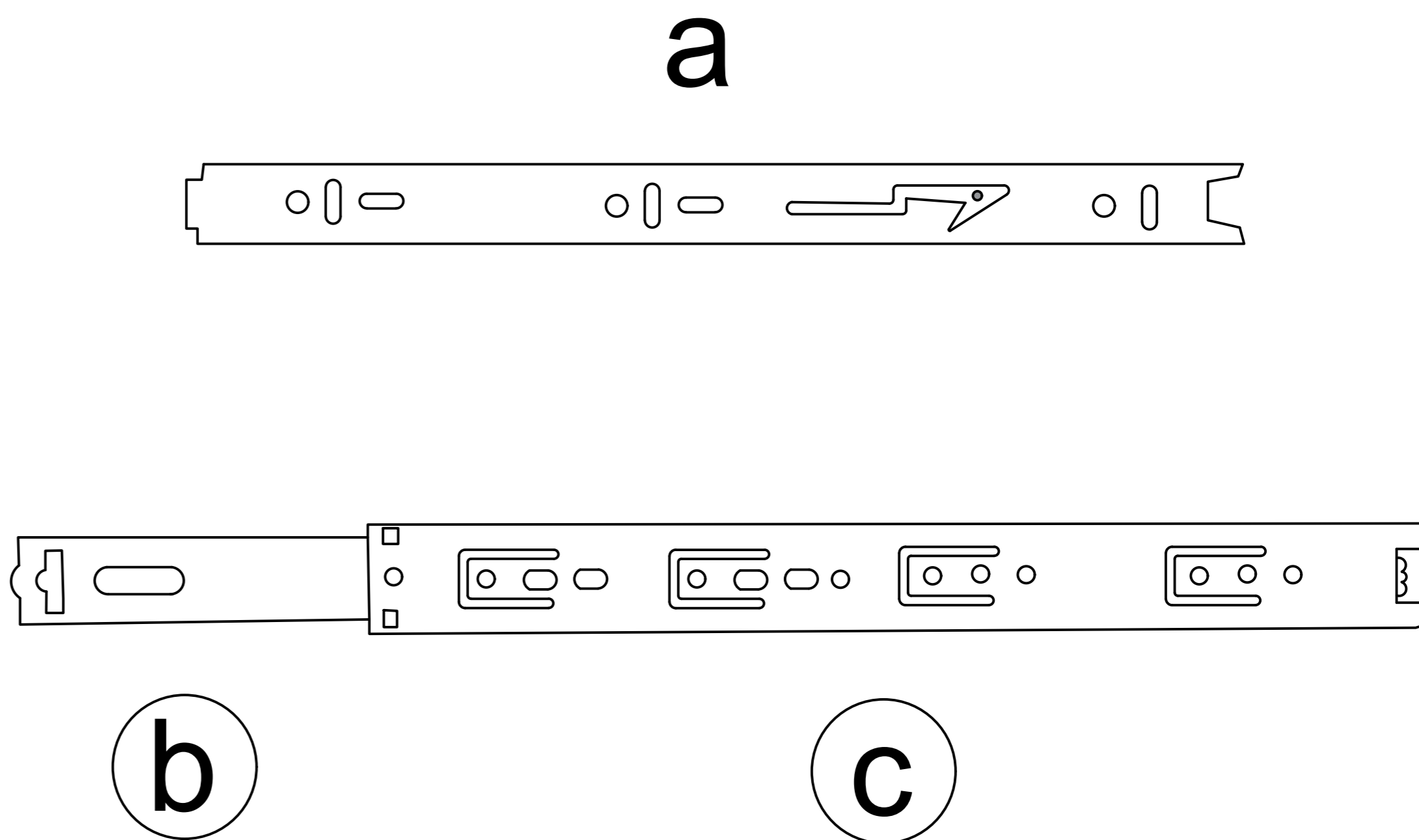

## Step 6

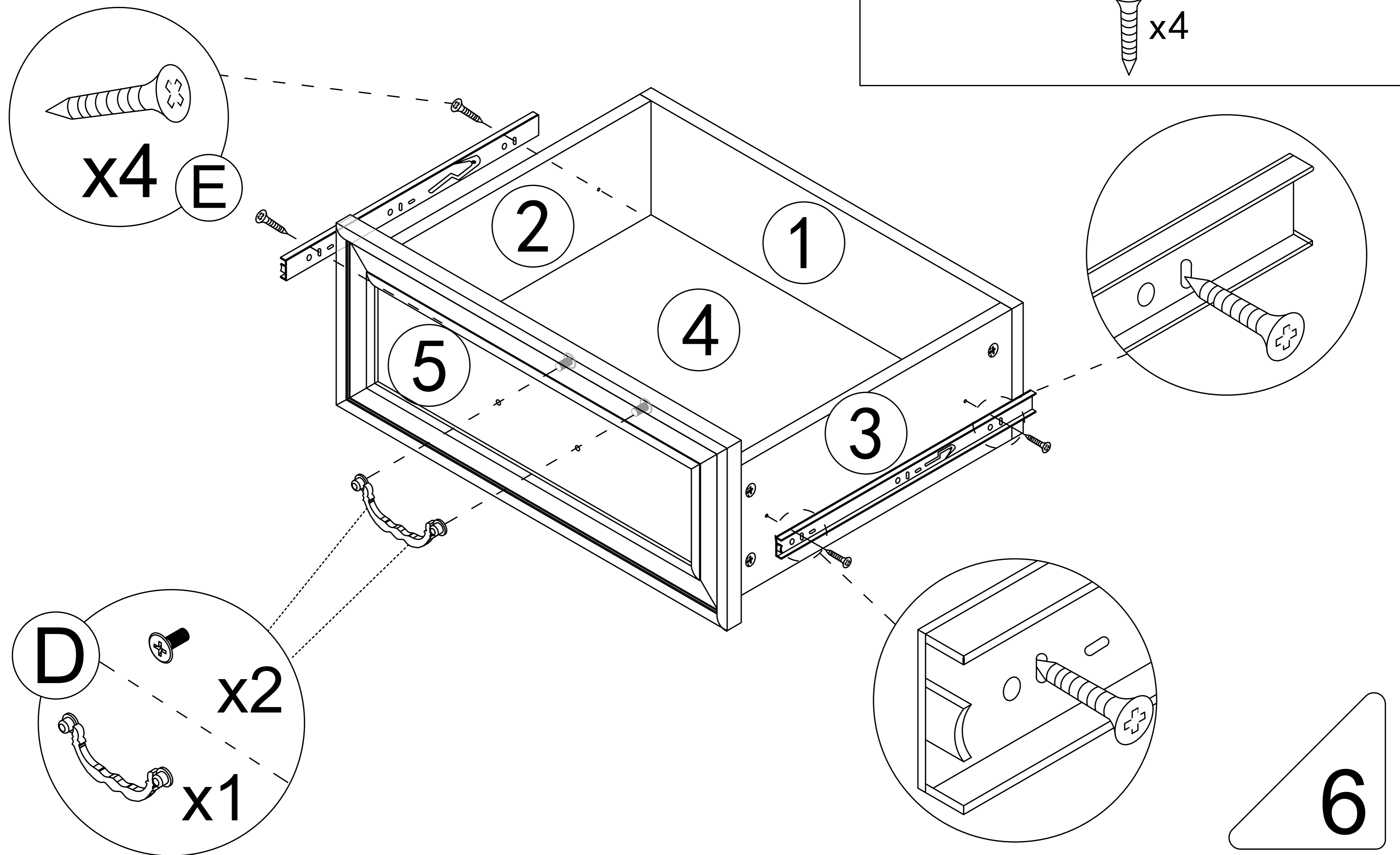
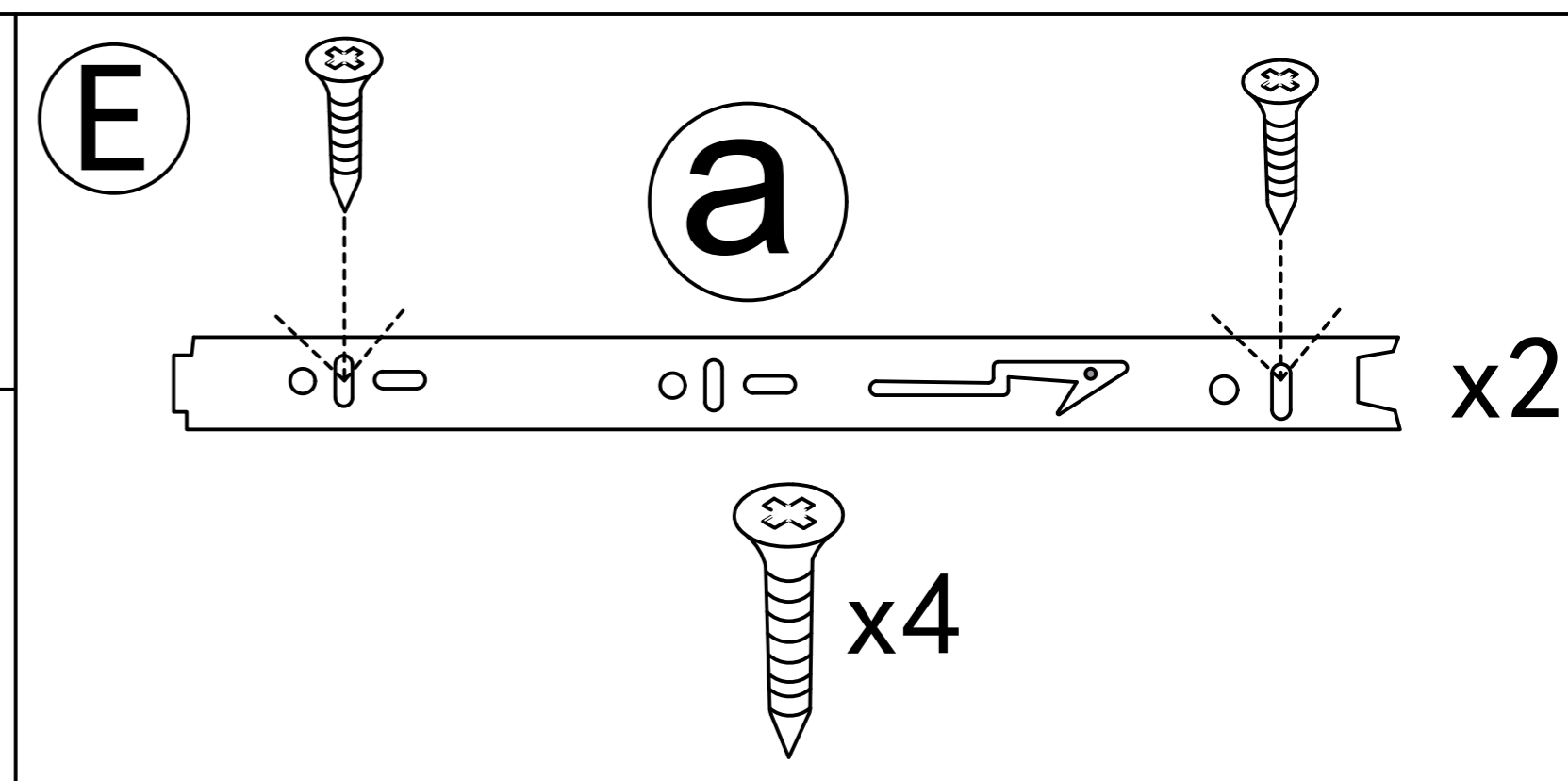
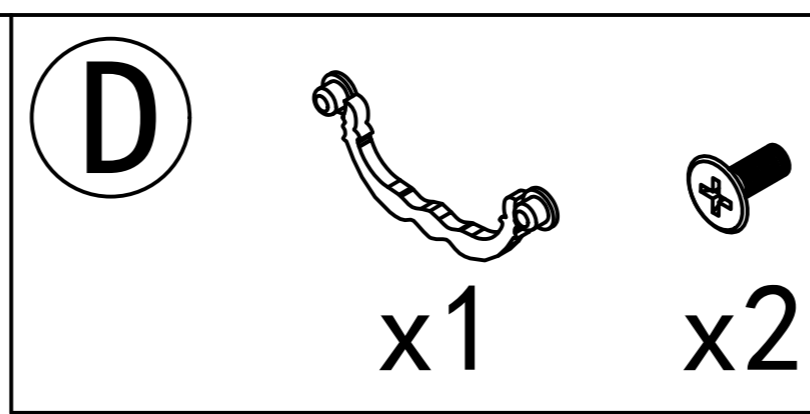

Step 7

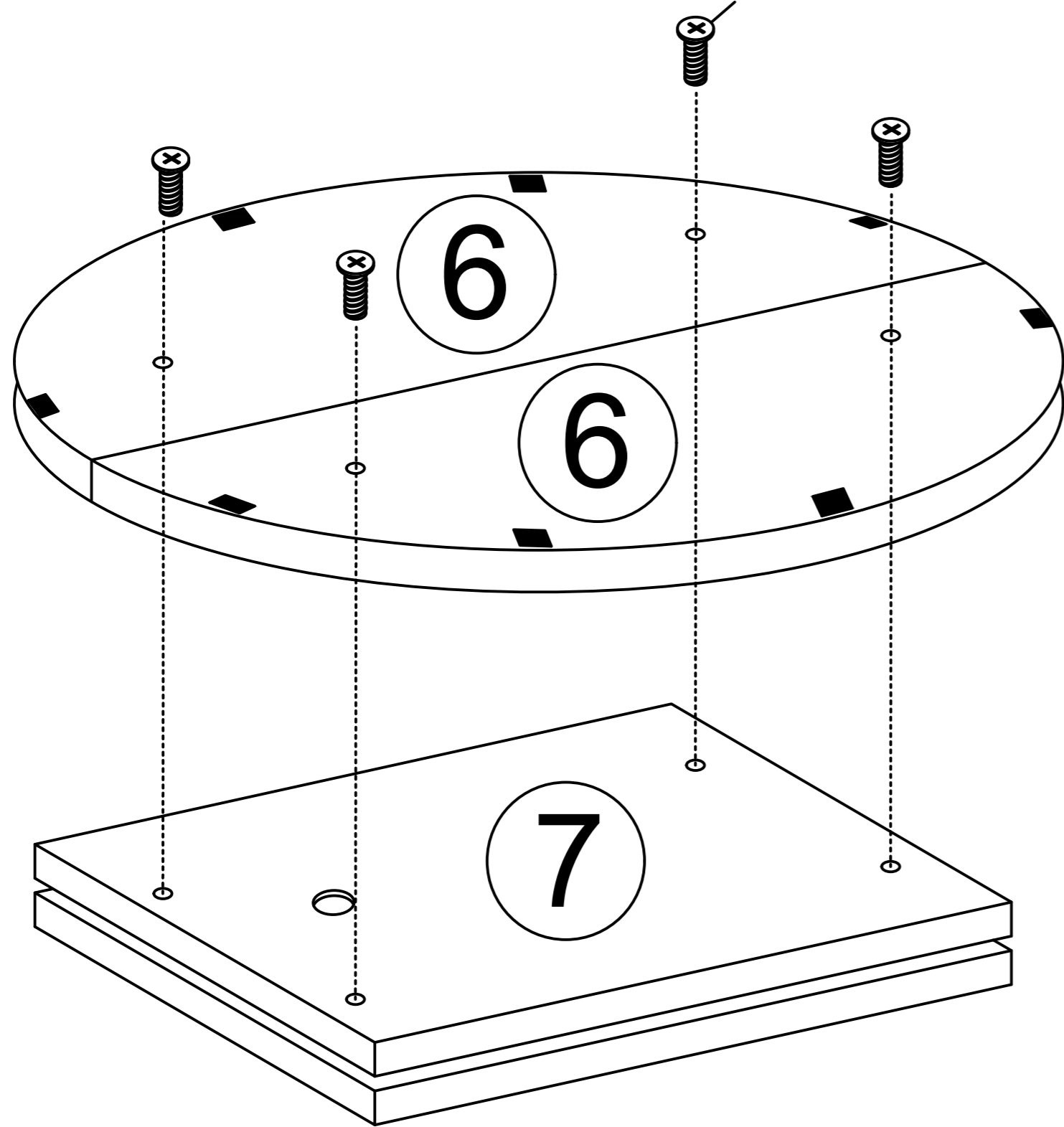
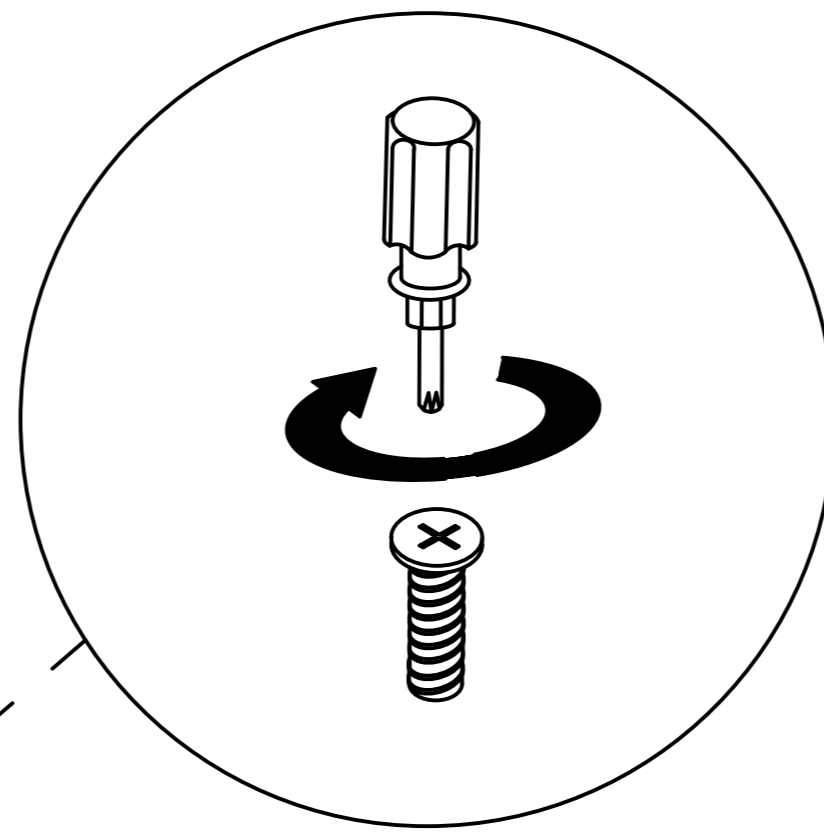
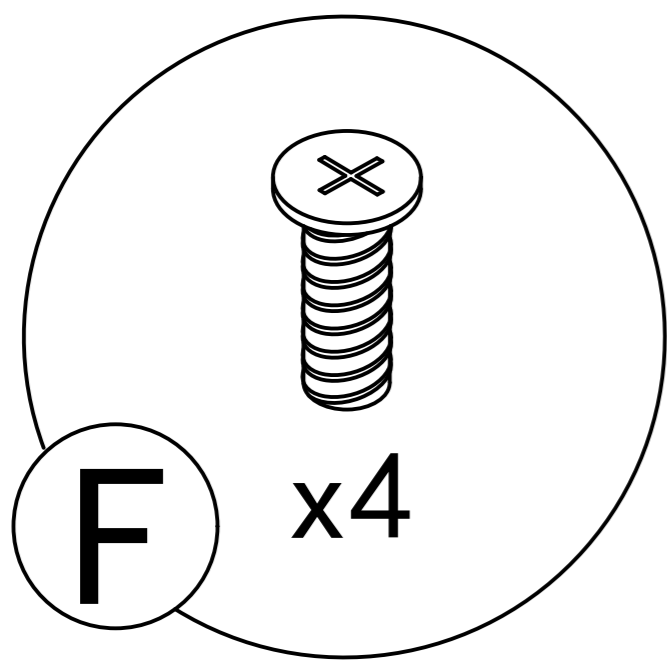
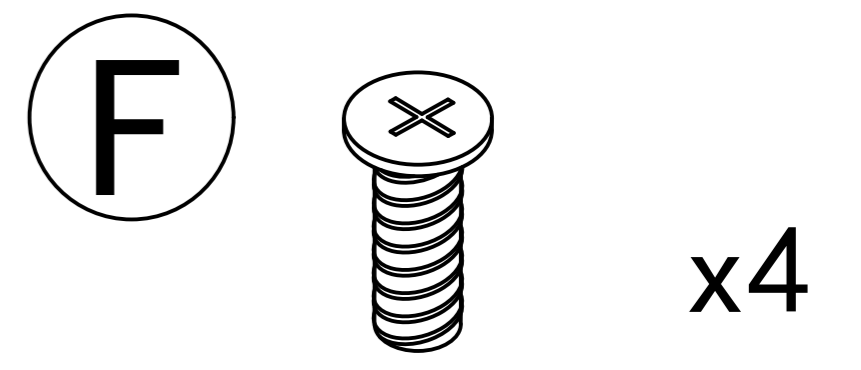

Turn the plank and  
screw it on

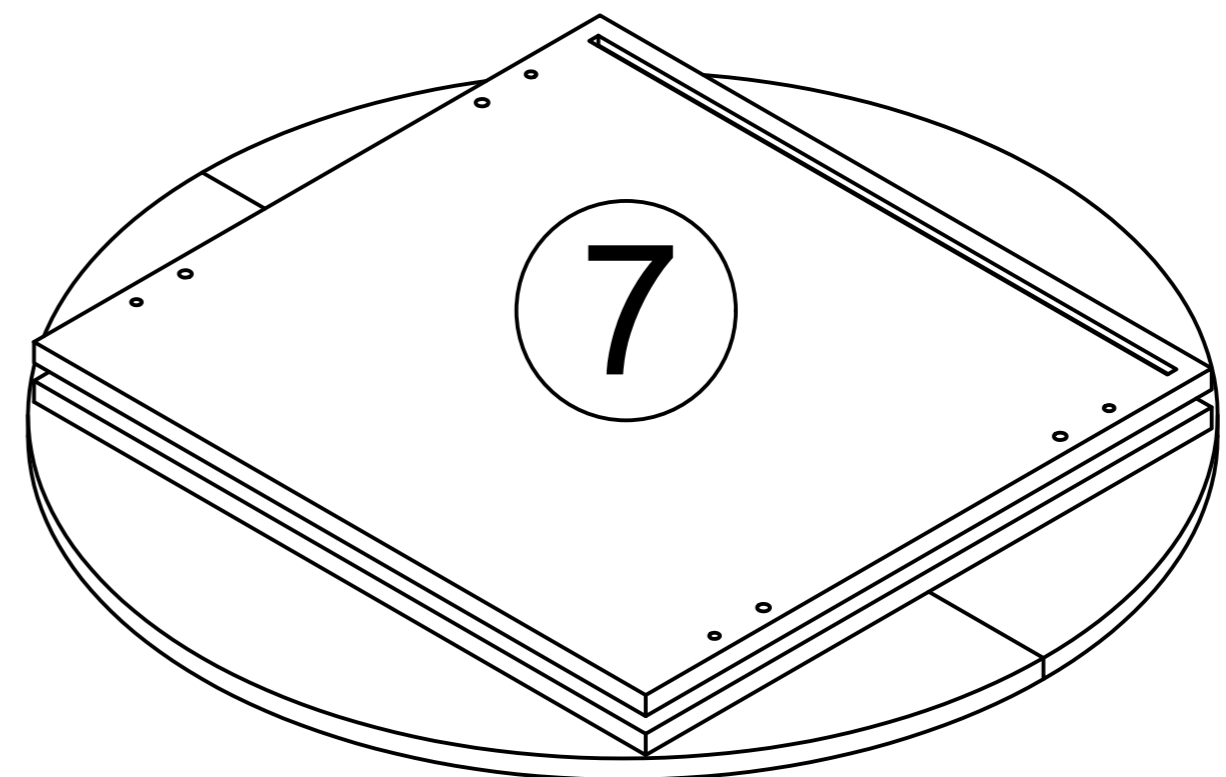

Step 8

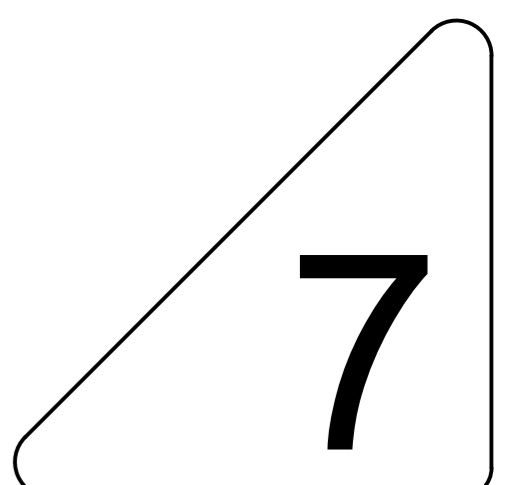
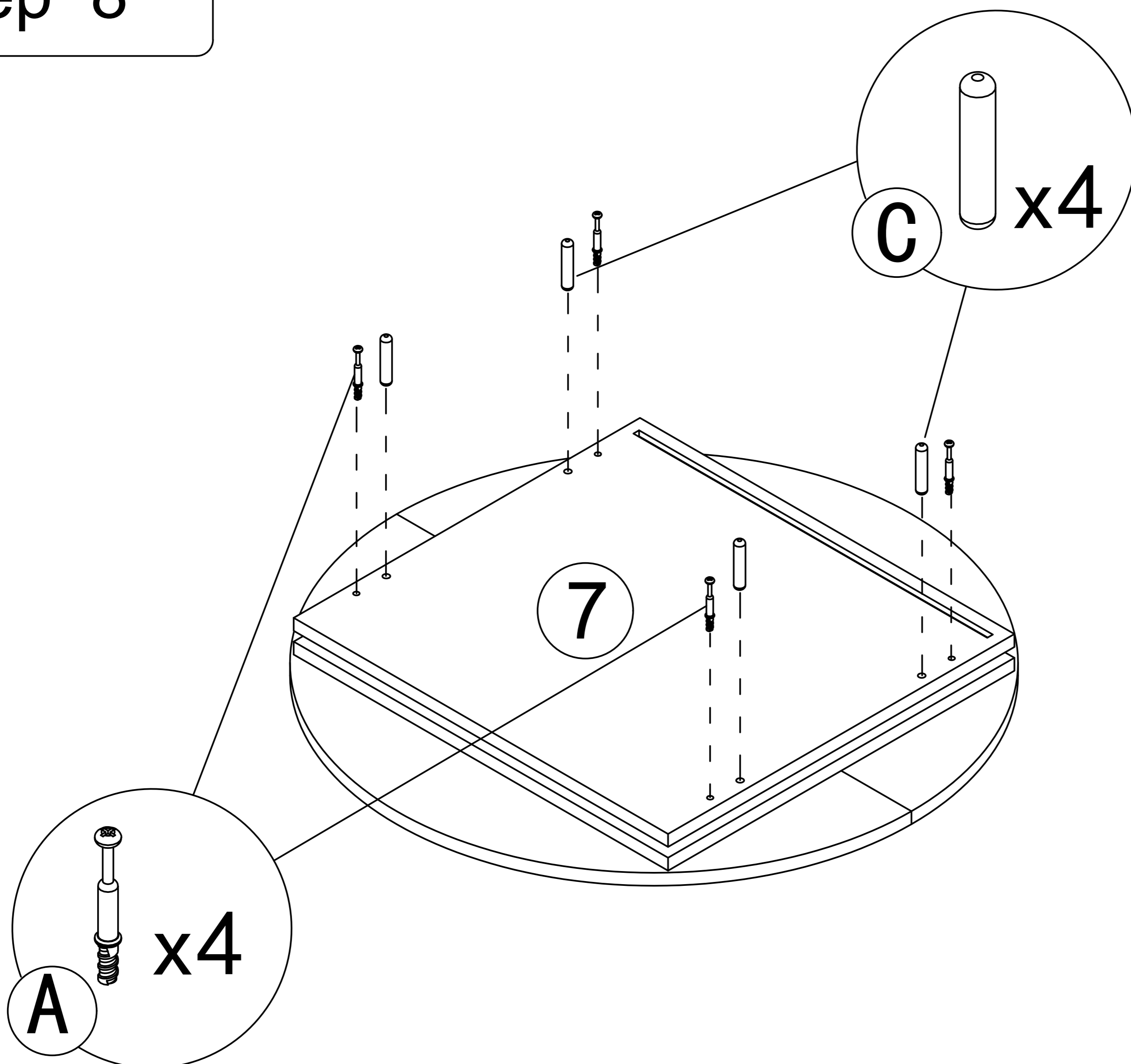
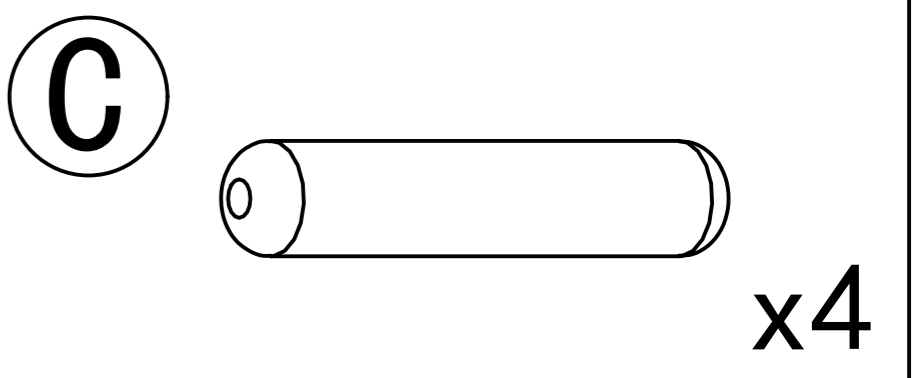
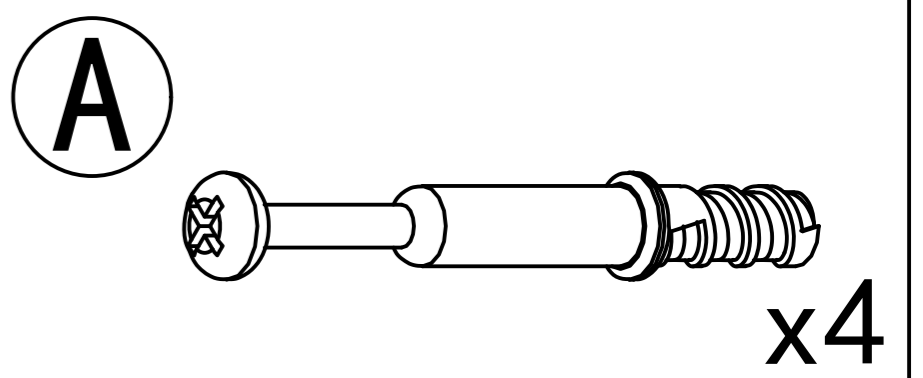

# Step 9

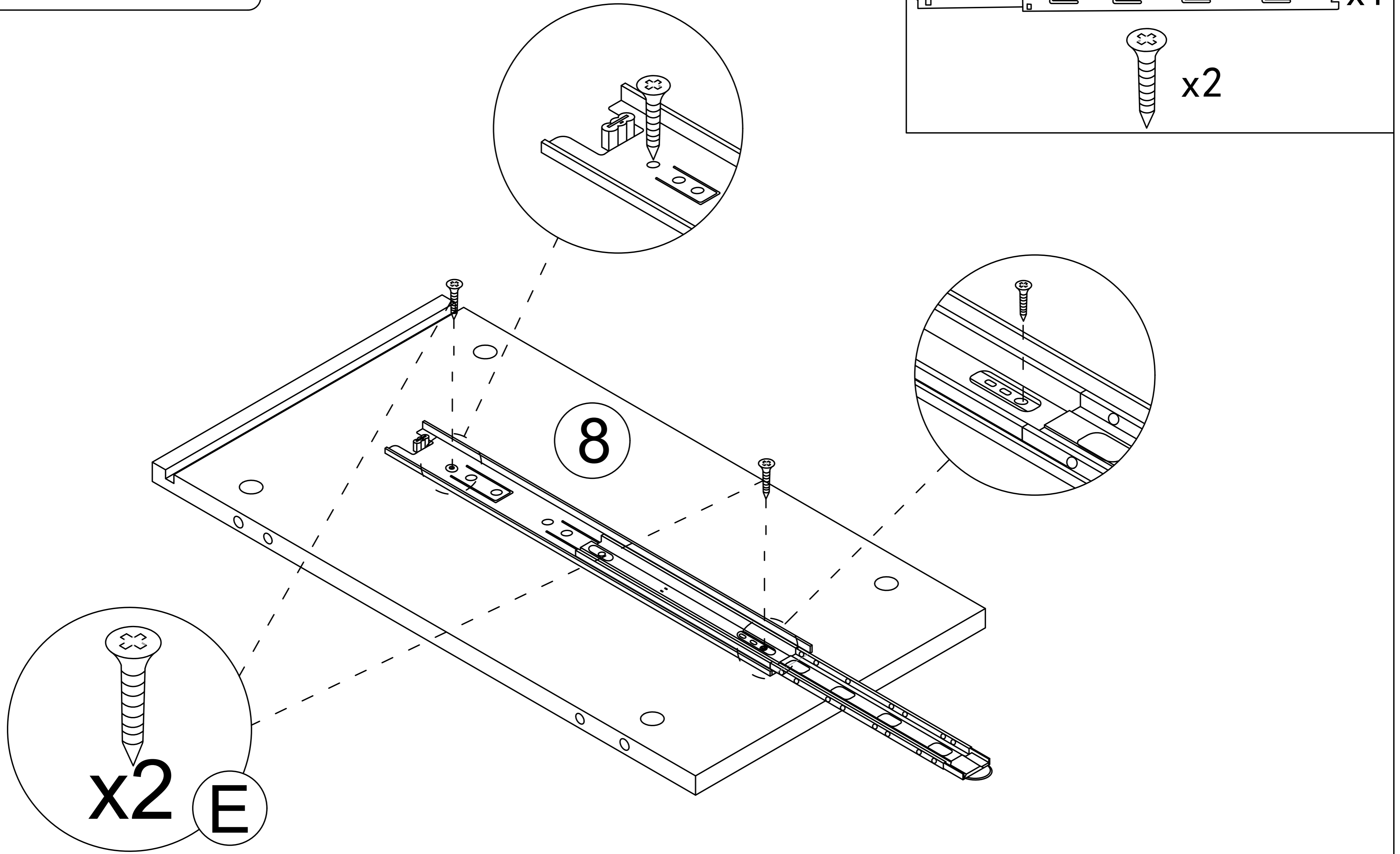

# Step 10

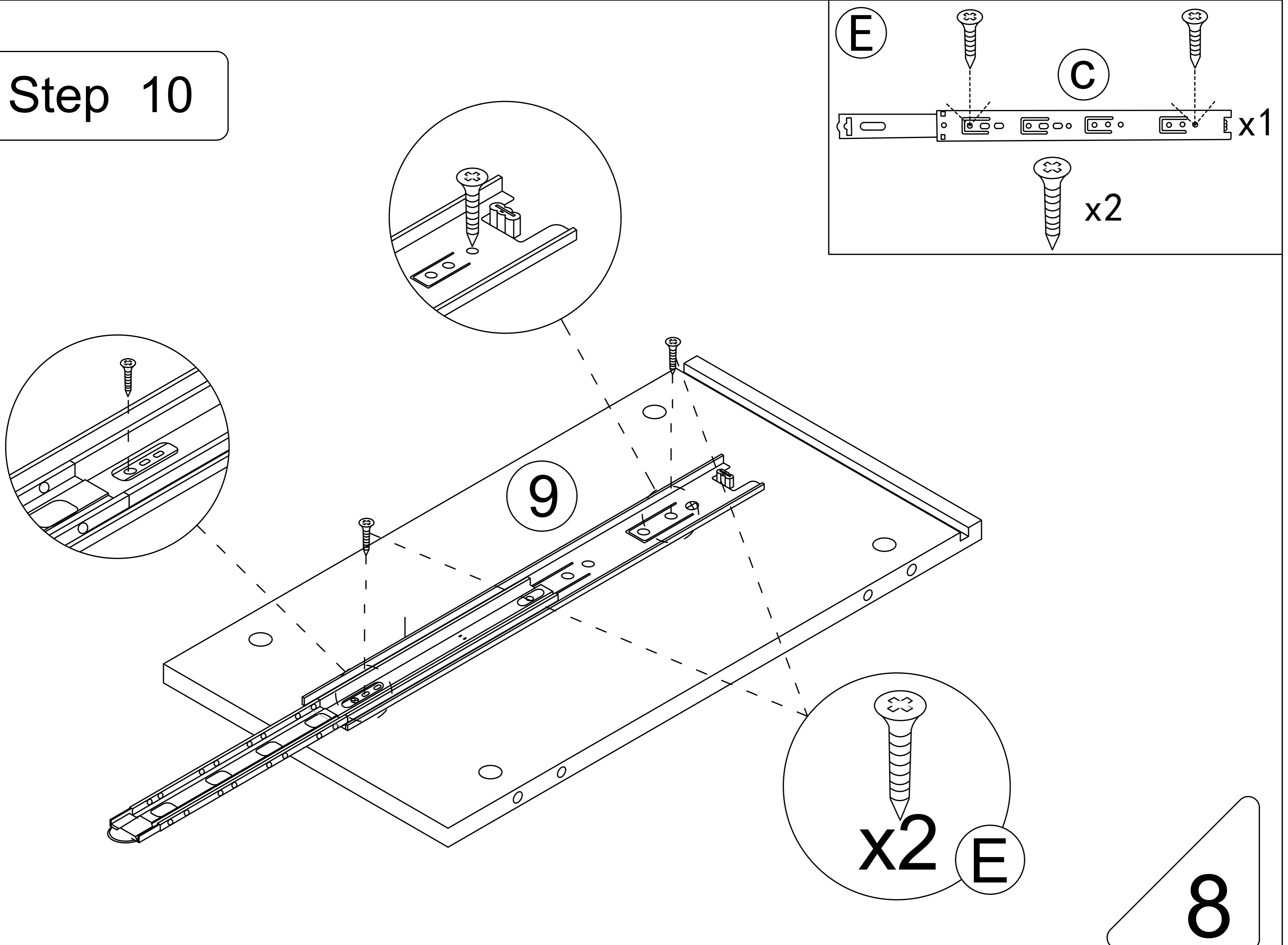

# Step 11

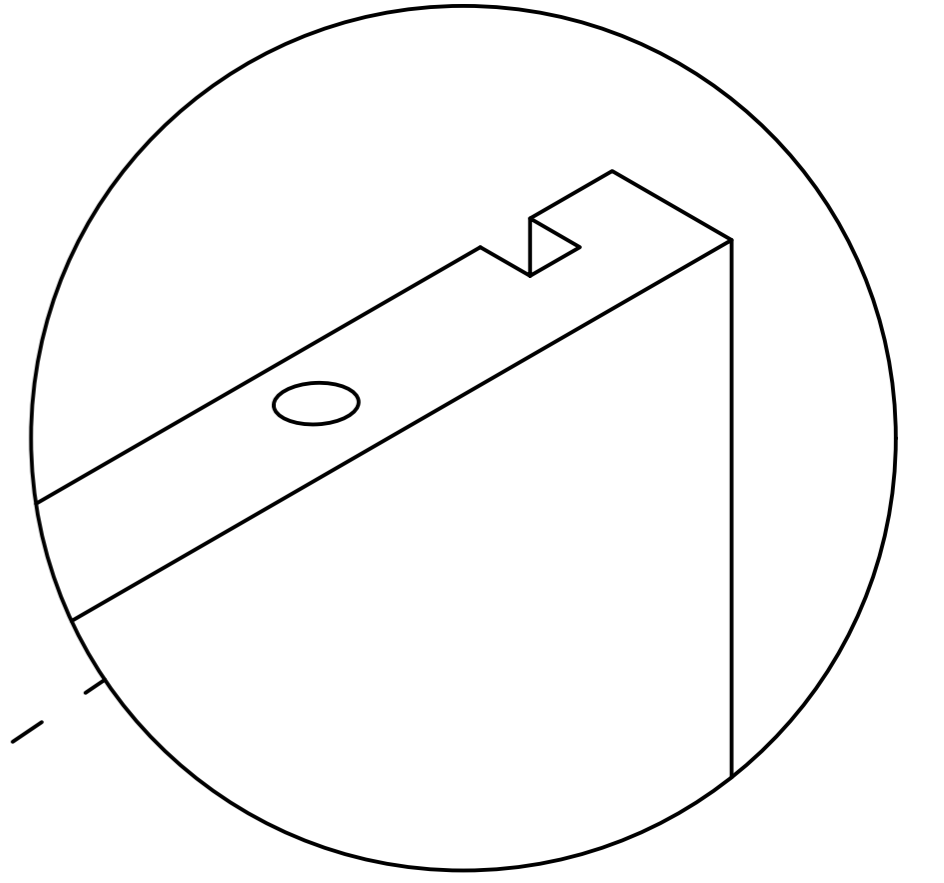
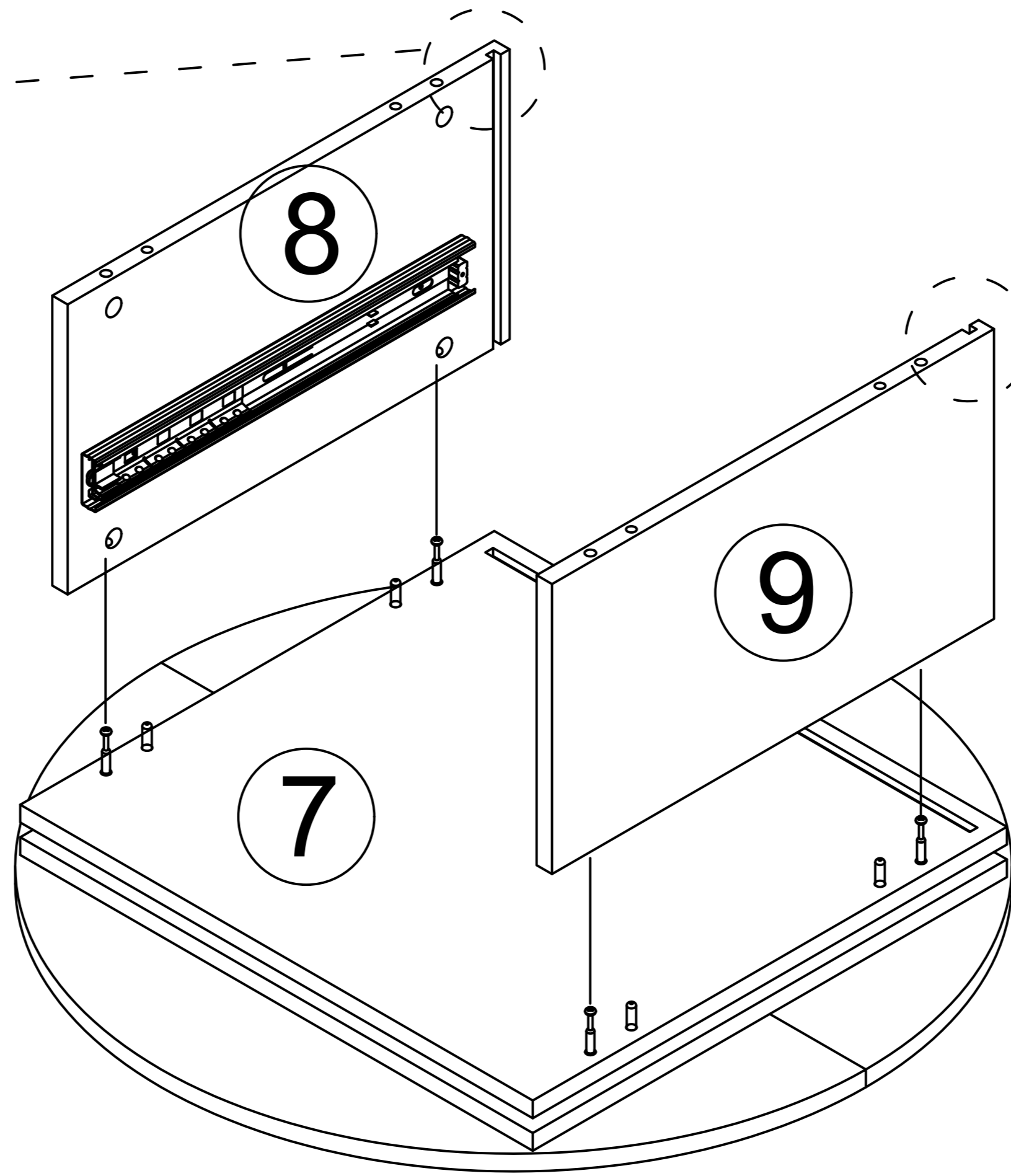
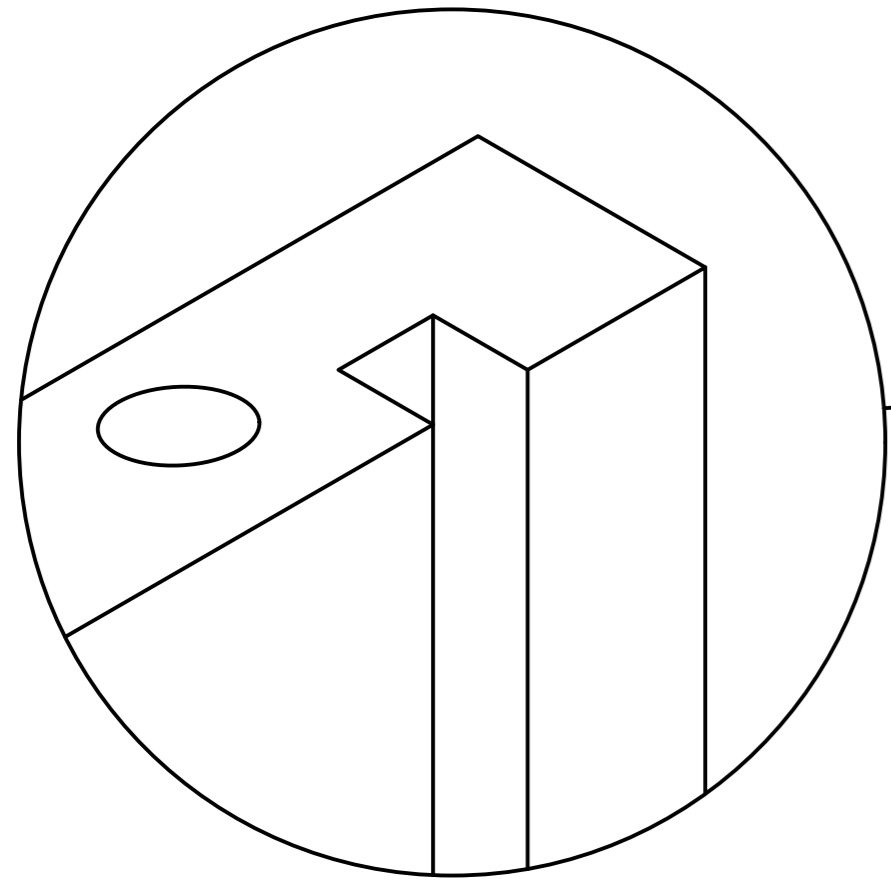

# Step 12

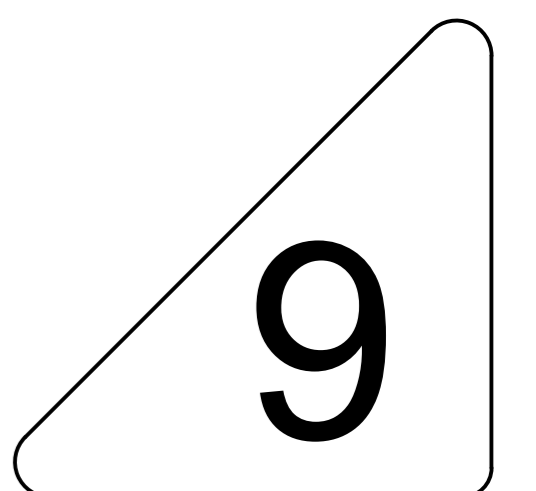
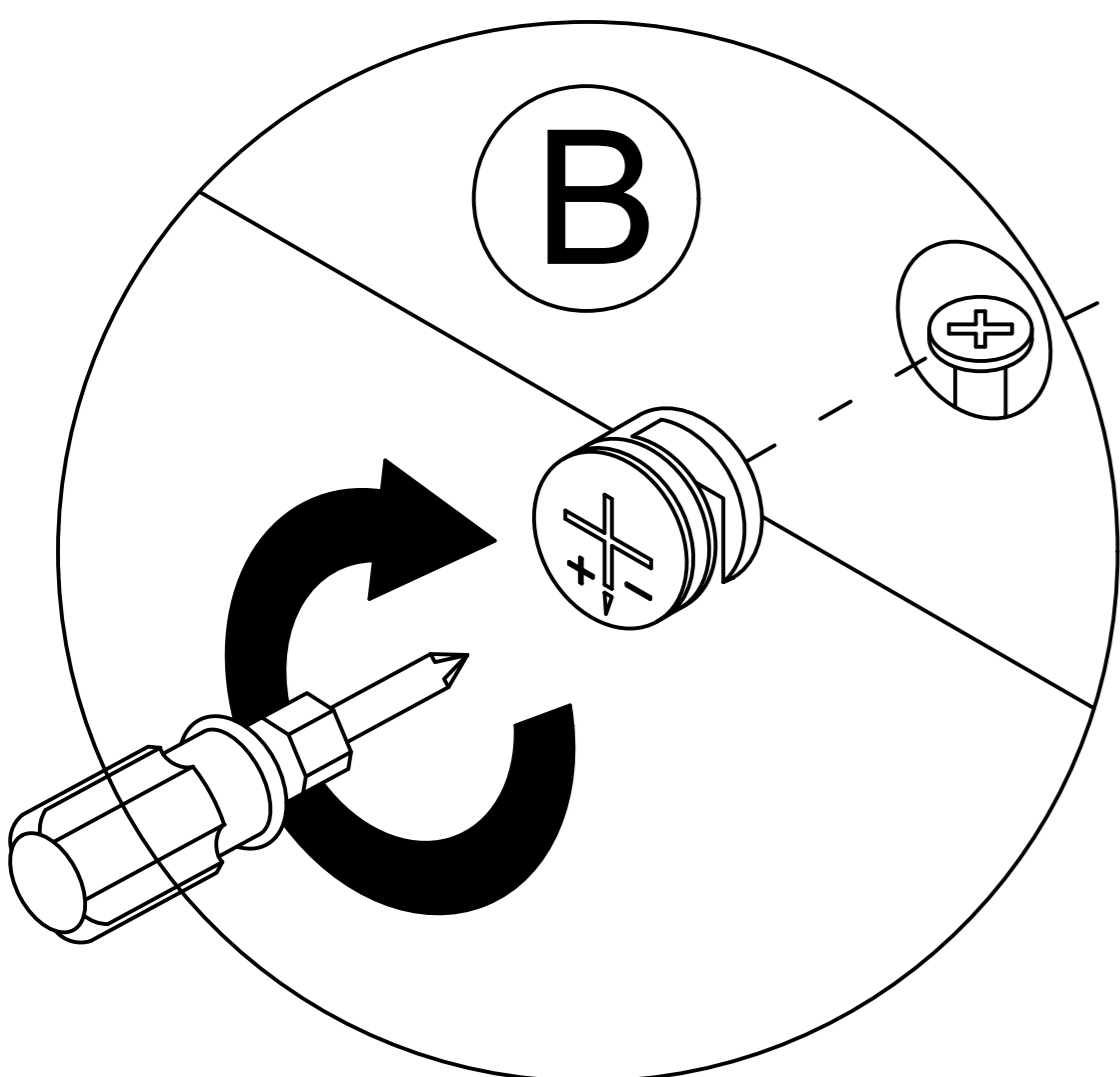
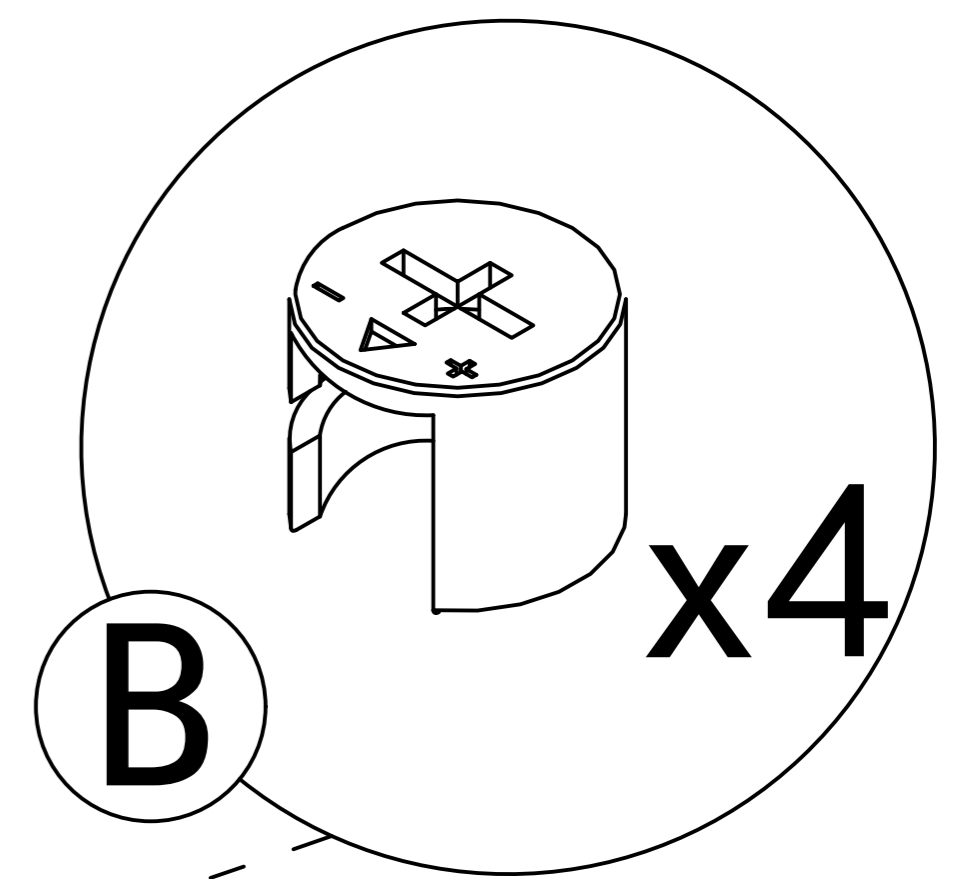
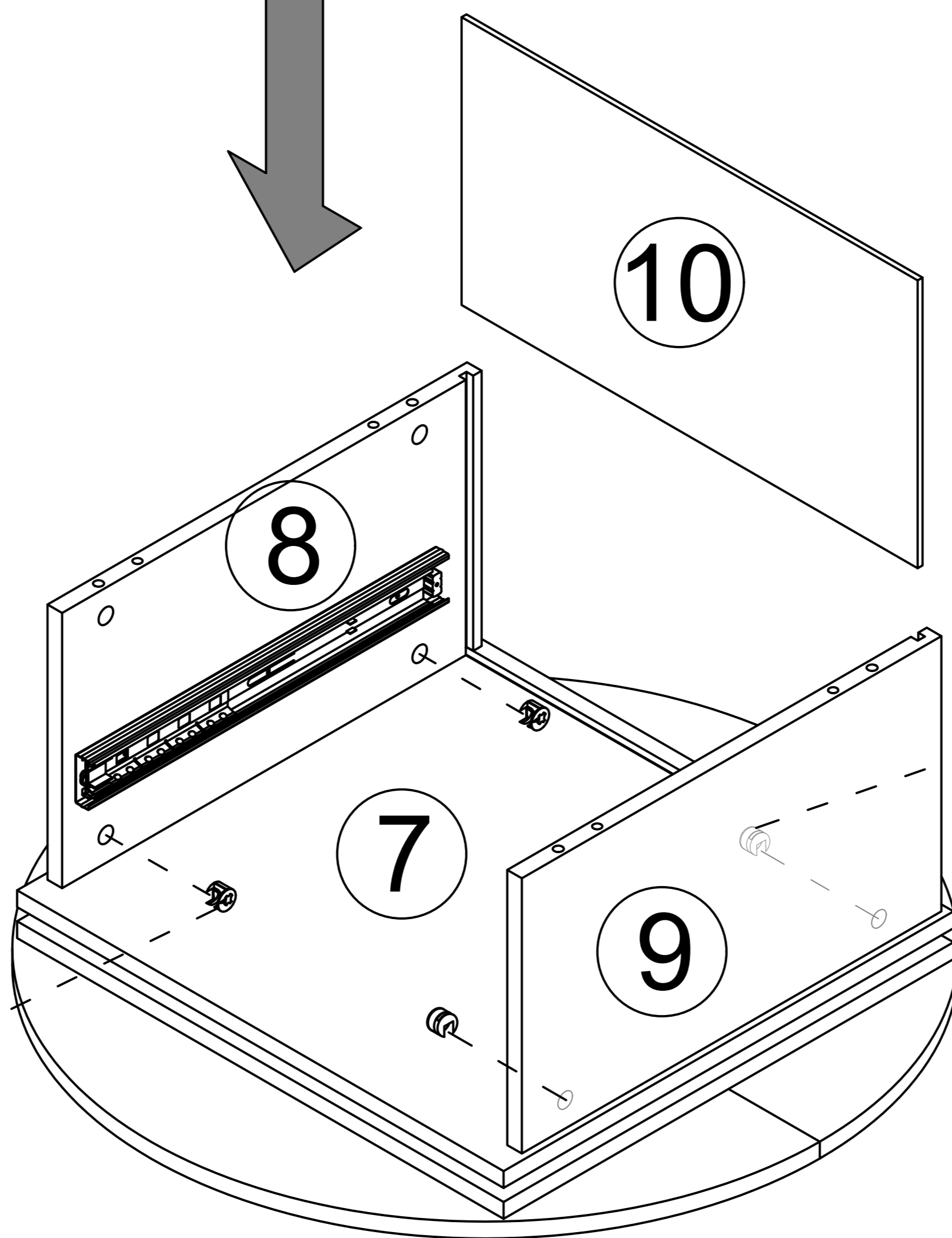
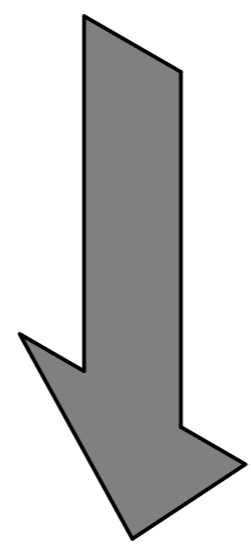
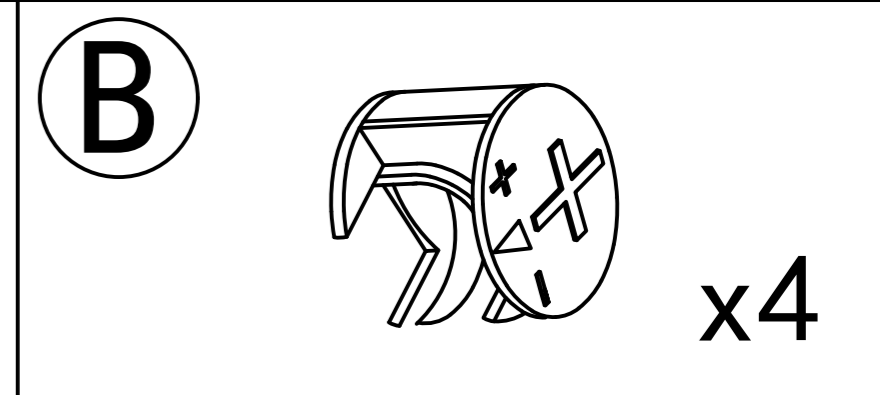

Step 13

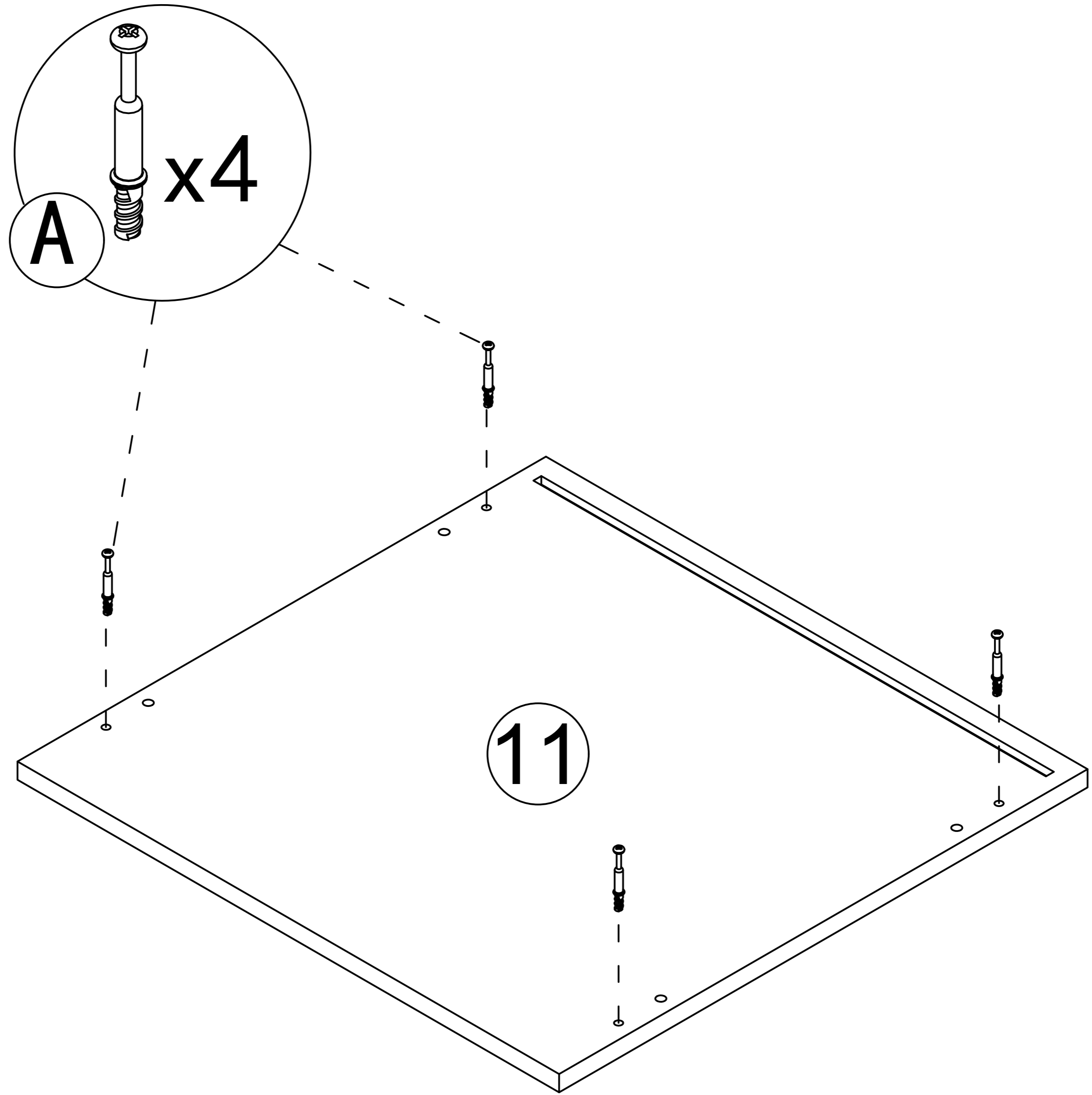
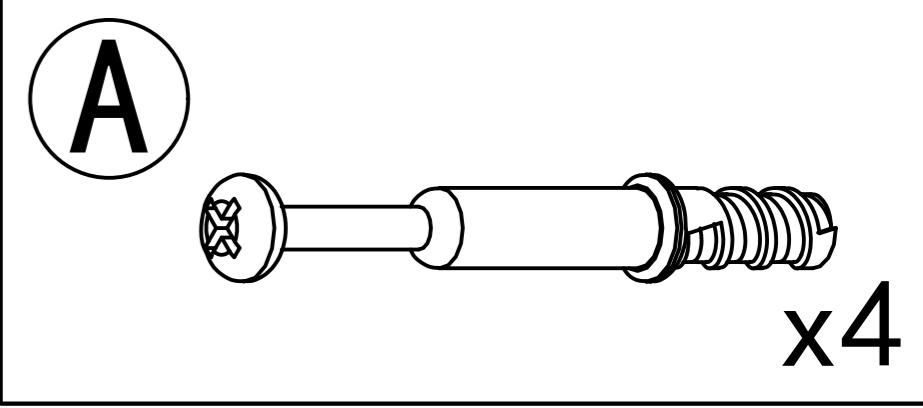

Step 14

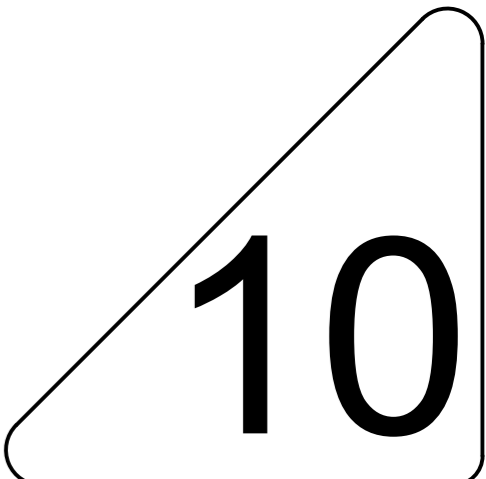
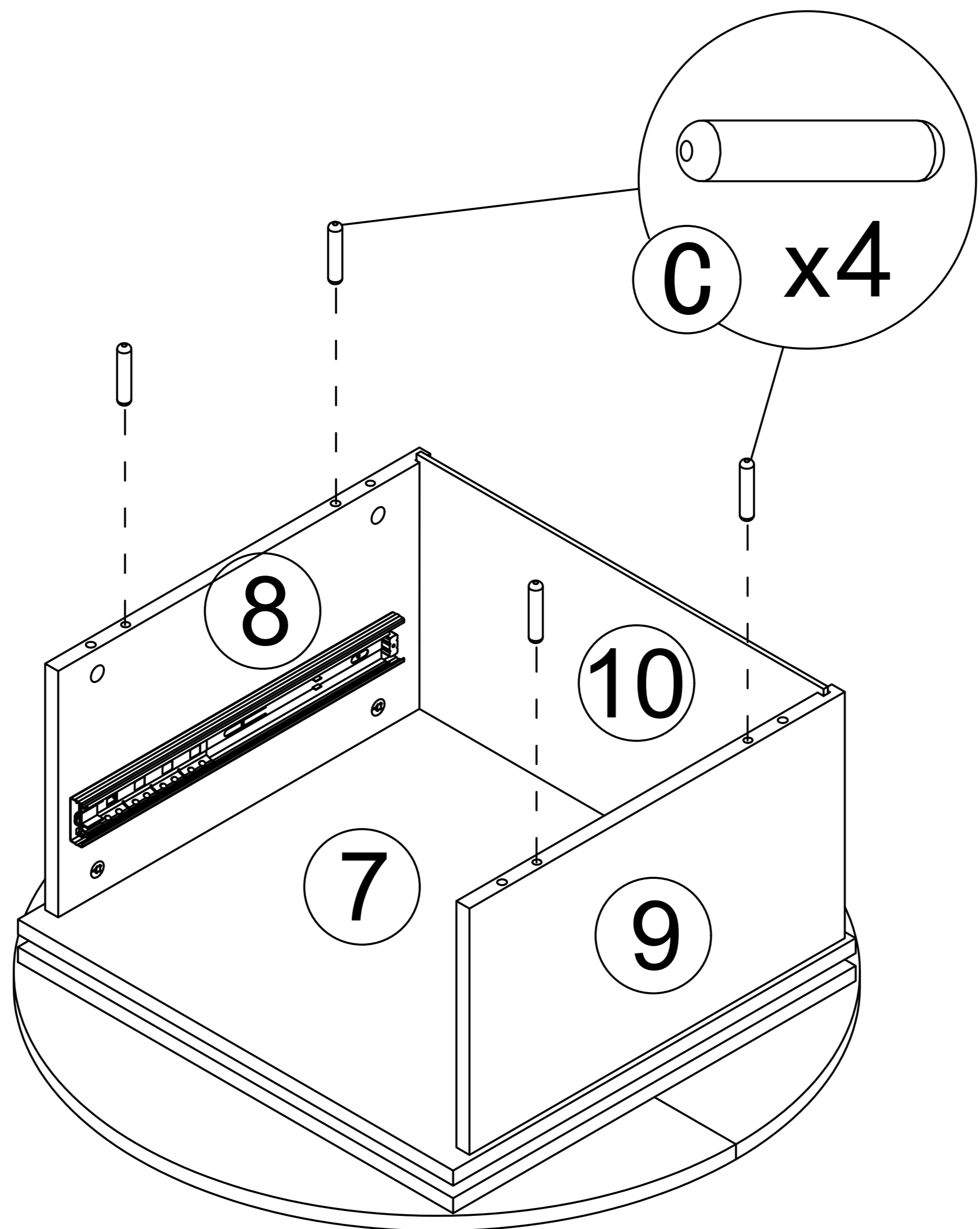
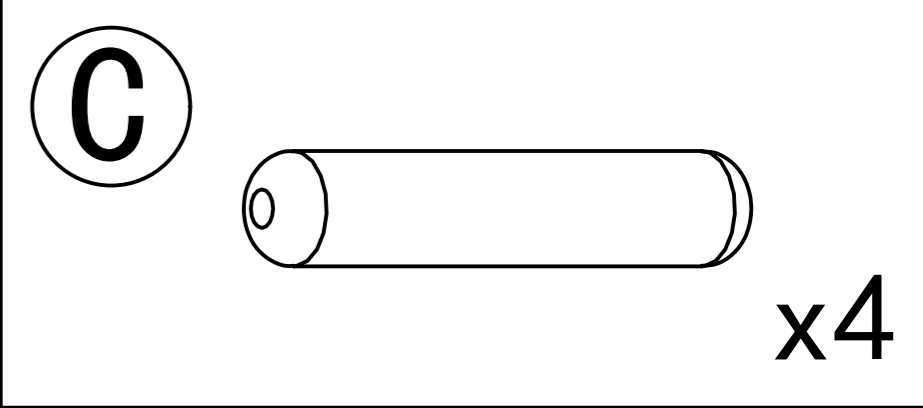

# Step 15

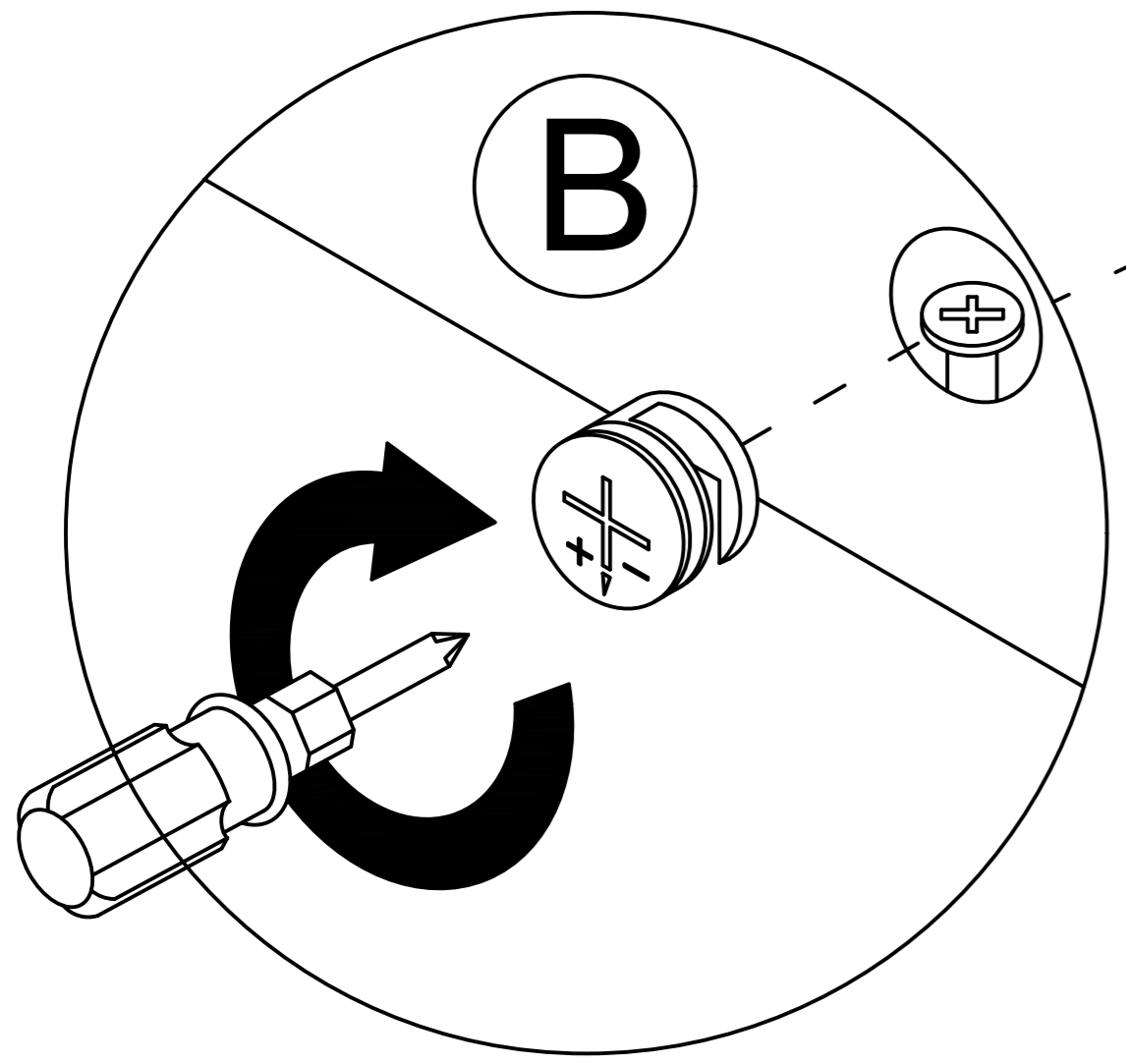
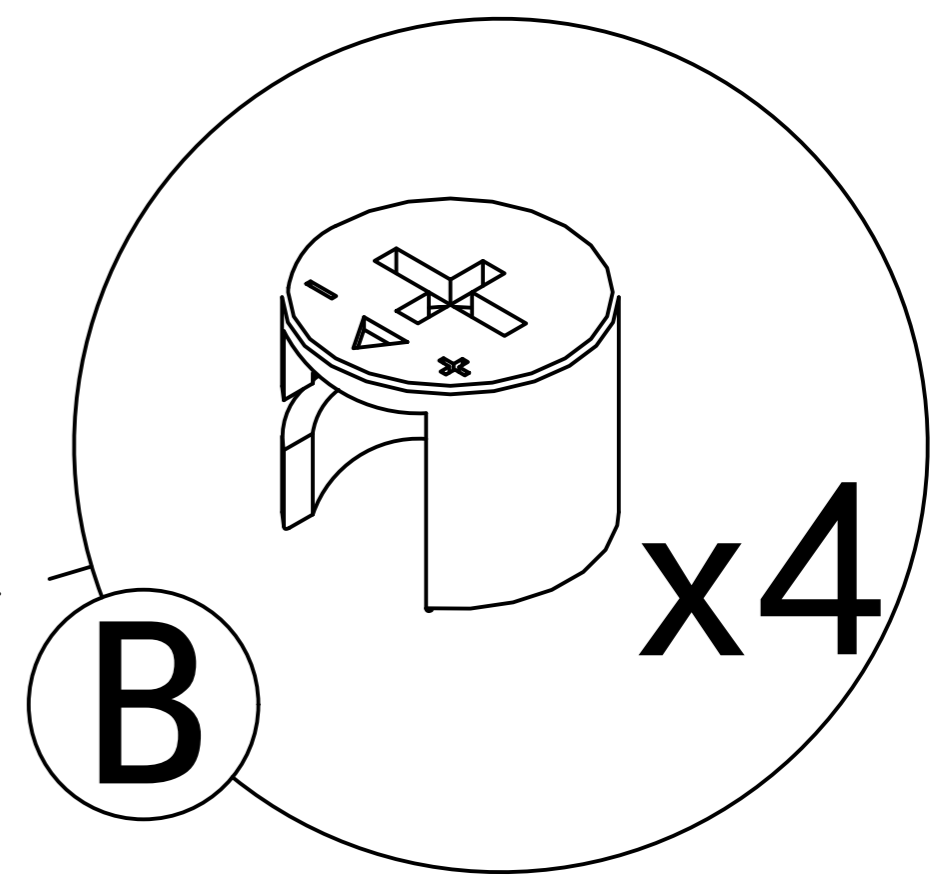
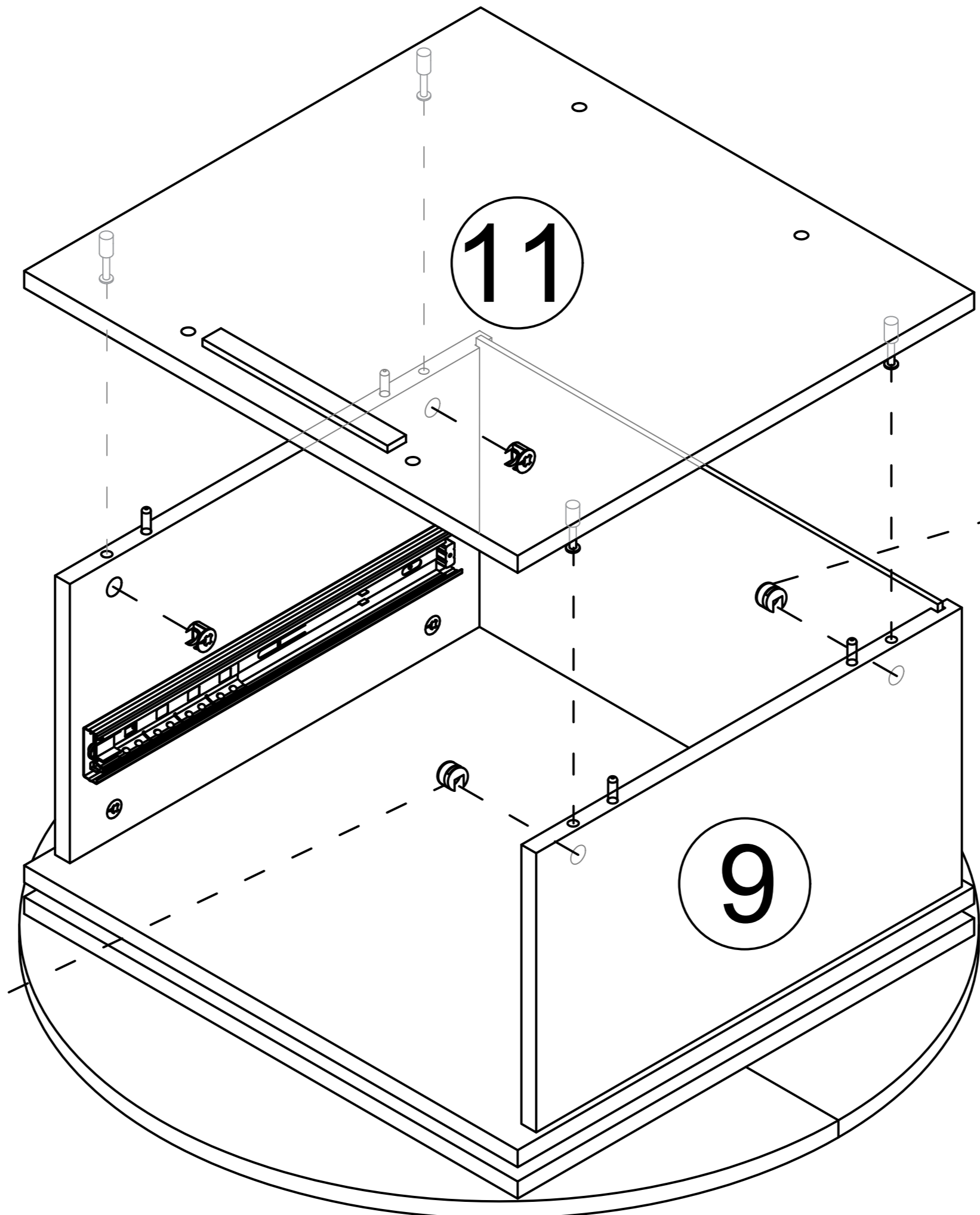
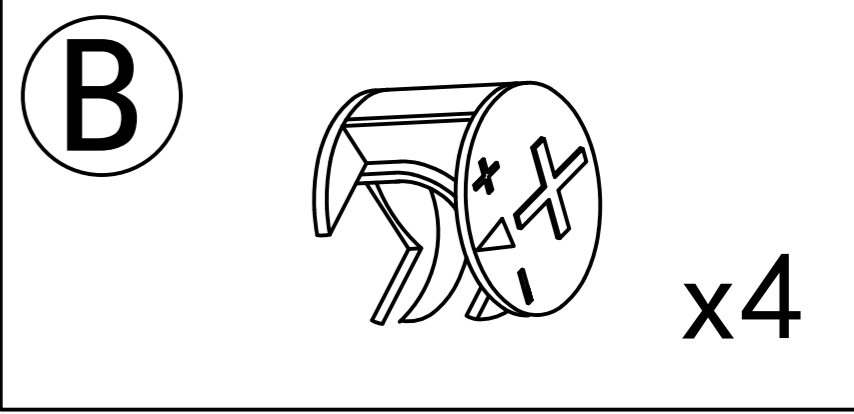

# Step 16

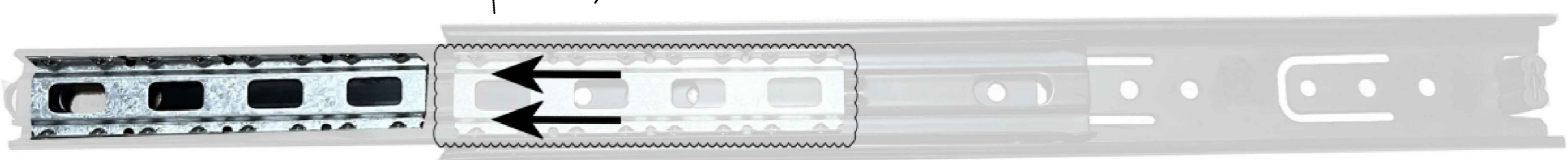
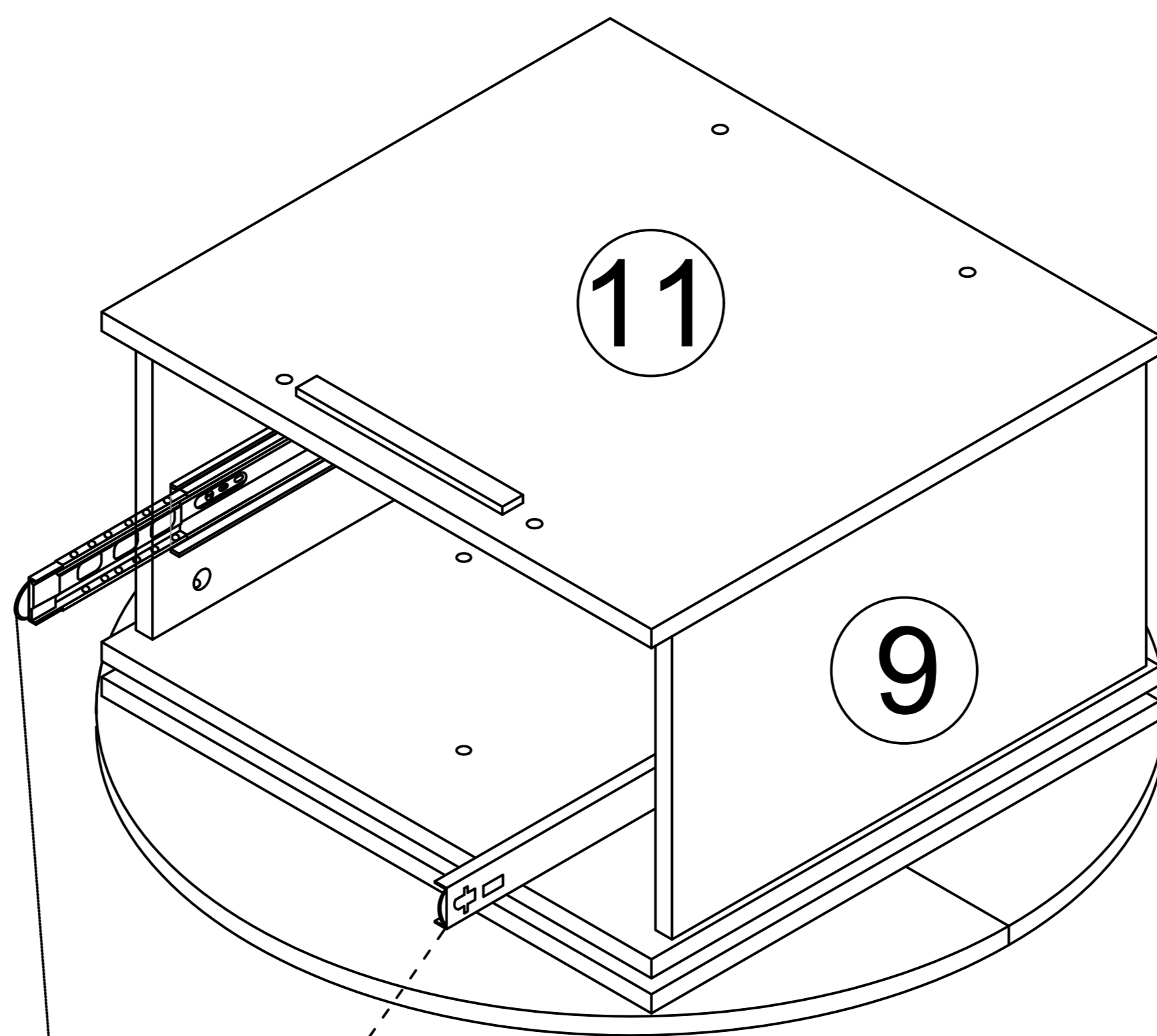

As shown, When installing the drawer, pull the guide rail out first, Slide beads are also pulled out.

# Step 17

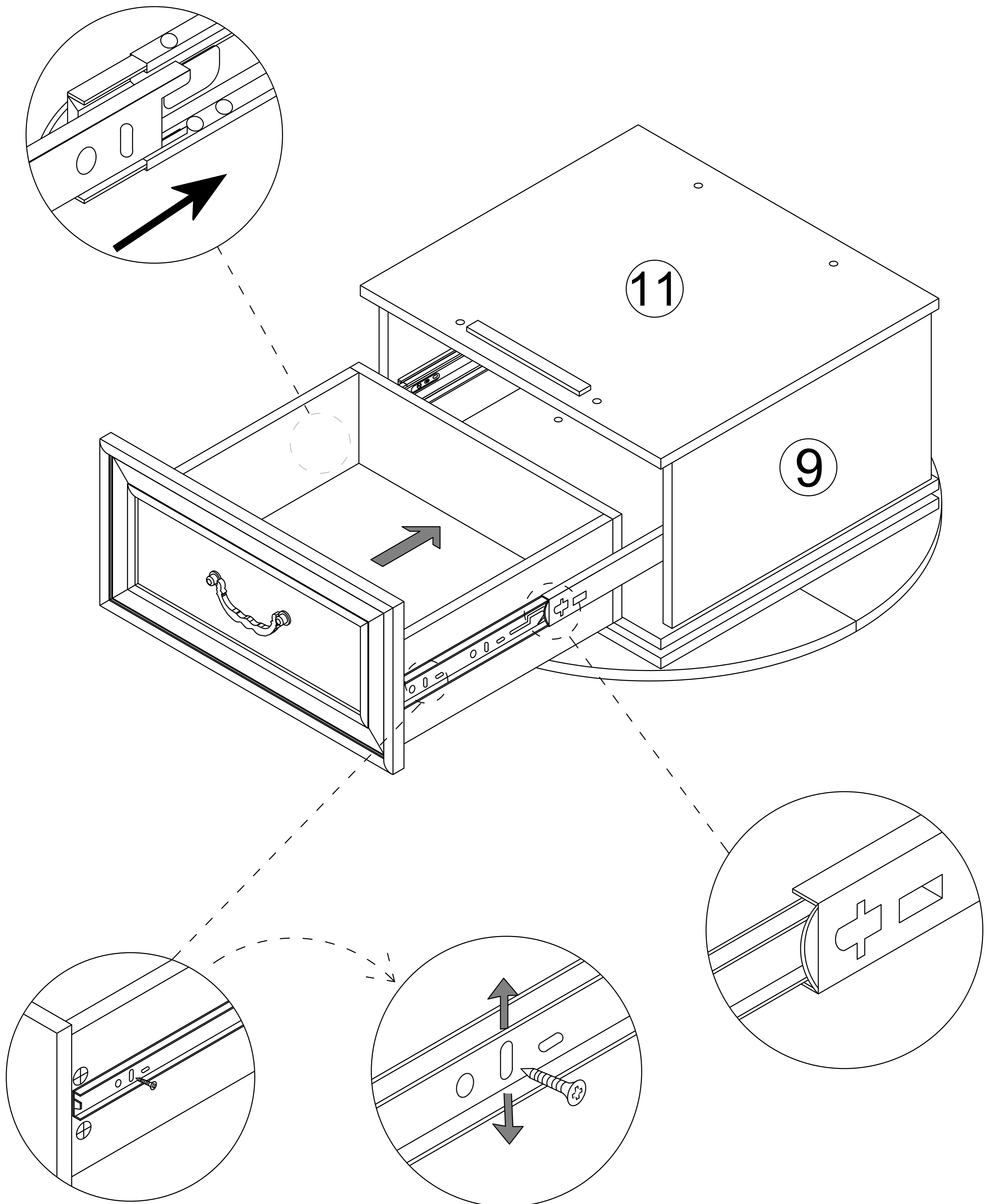

If a large gap is found after installing the drawer the slide rail can be moved up and down to adjust the gap

Step 18

G

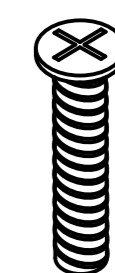

x2

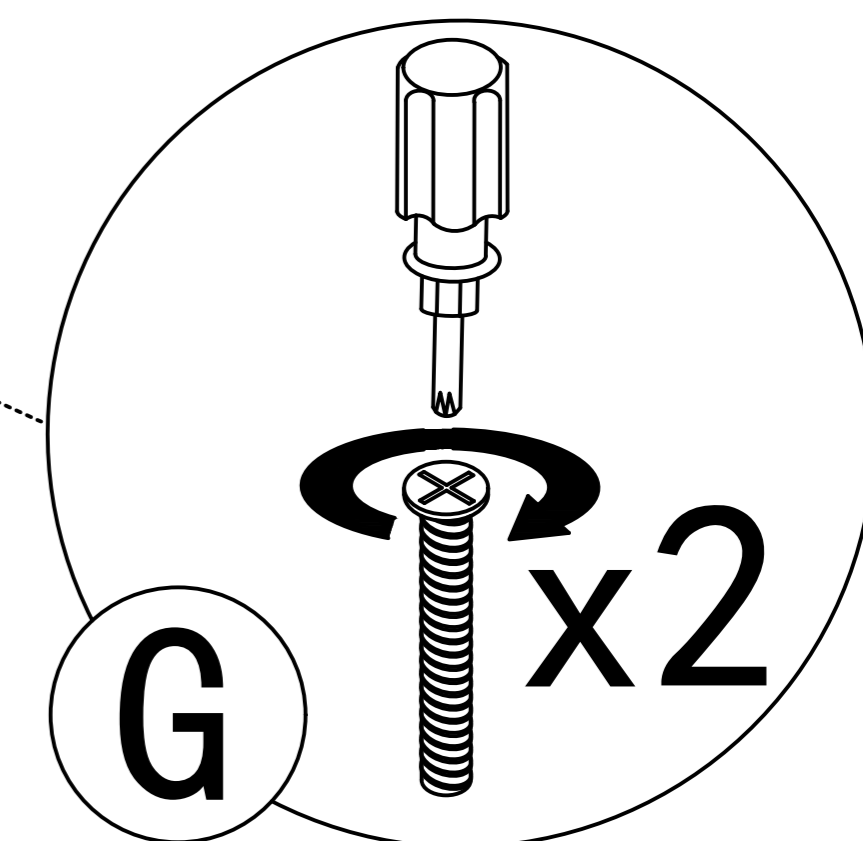
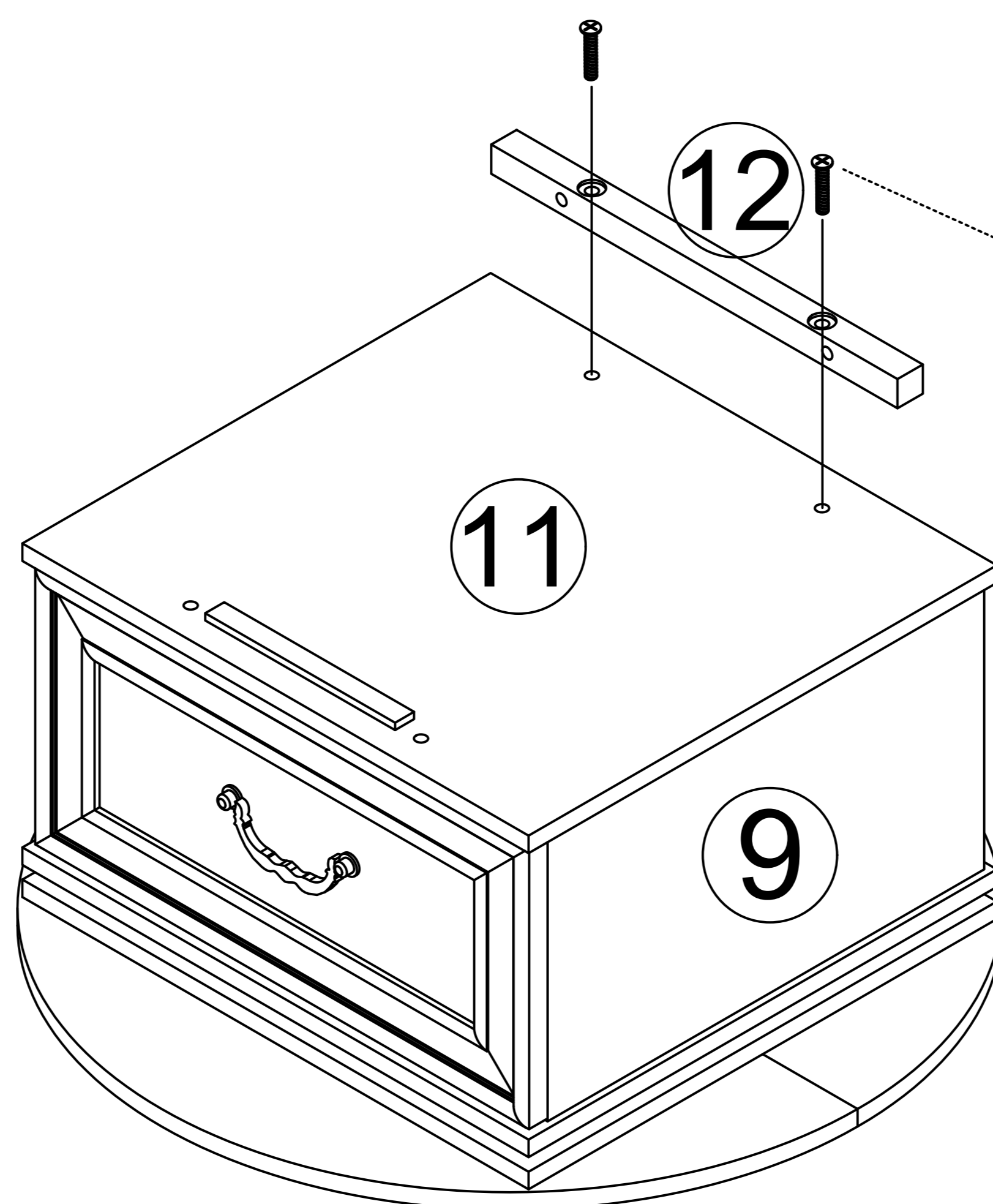

Step 19

H

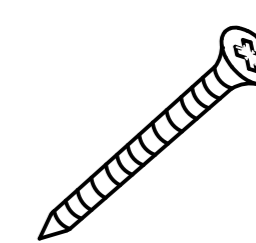

x2

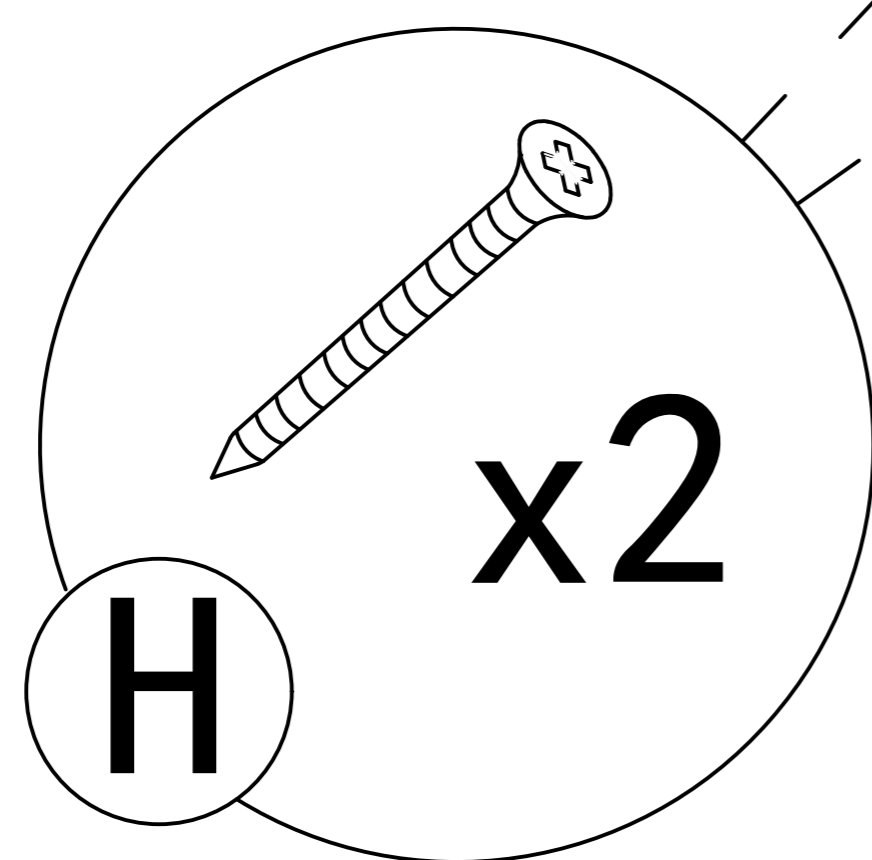
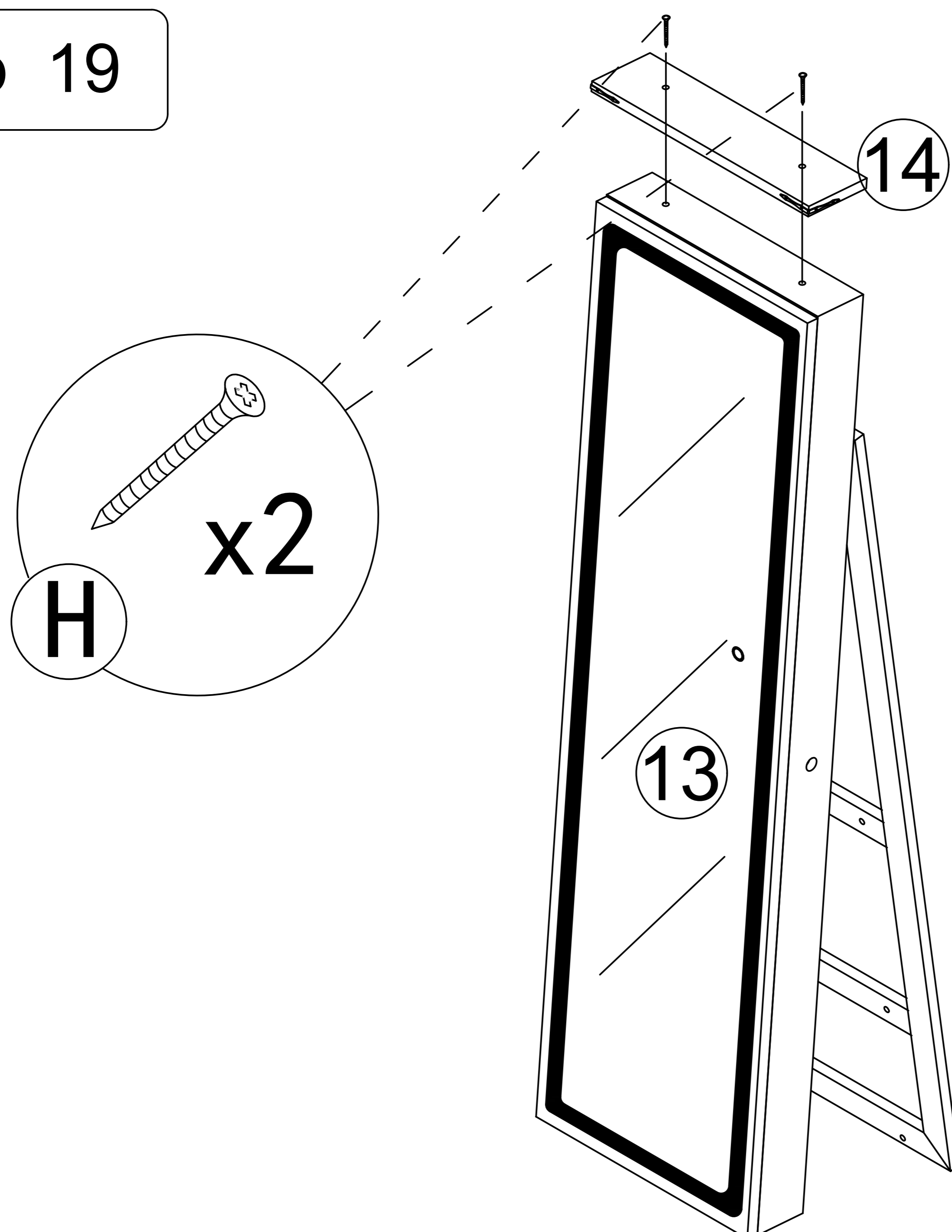

# Step 20

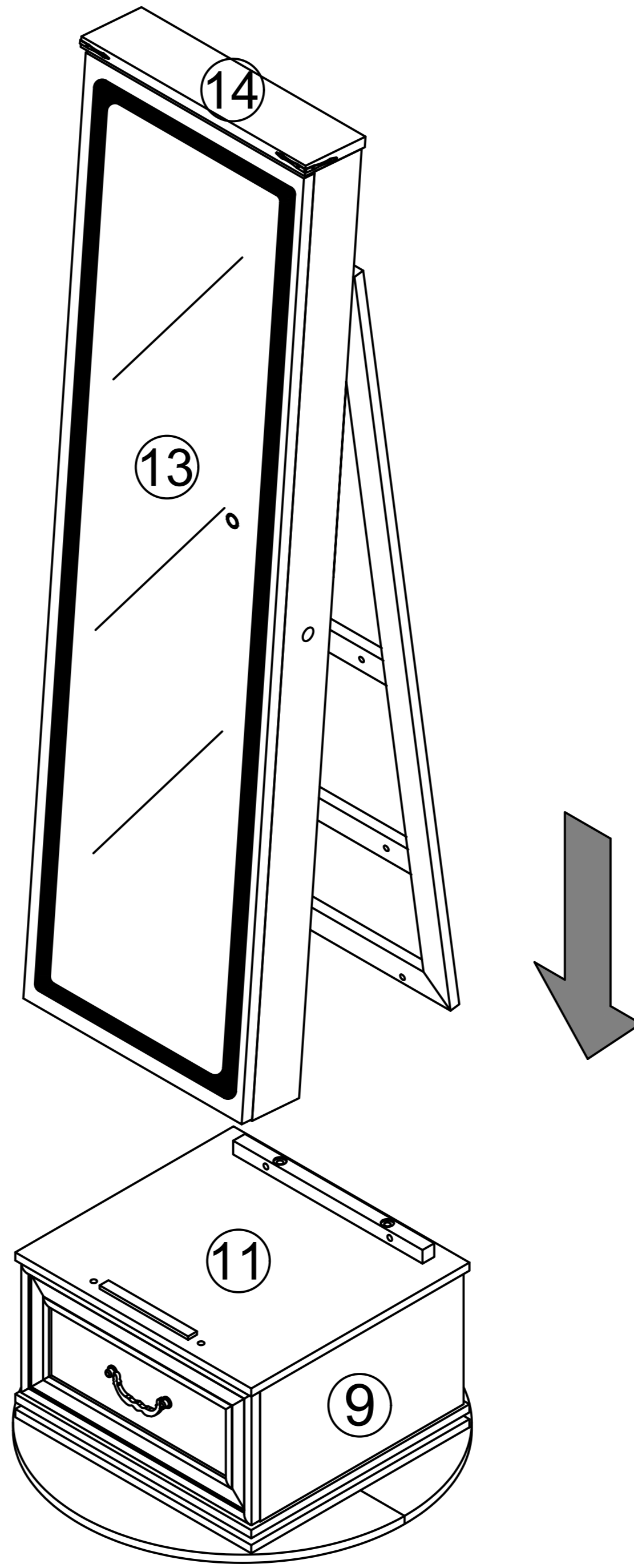

# Step 21

**Battery installation**  
(Tip: use 3 AA Batteries)

G

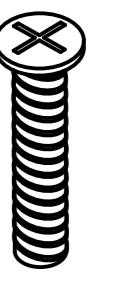



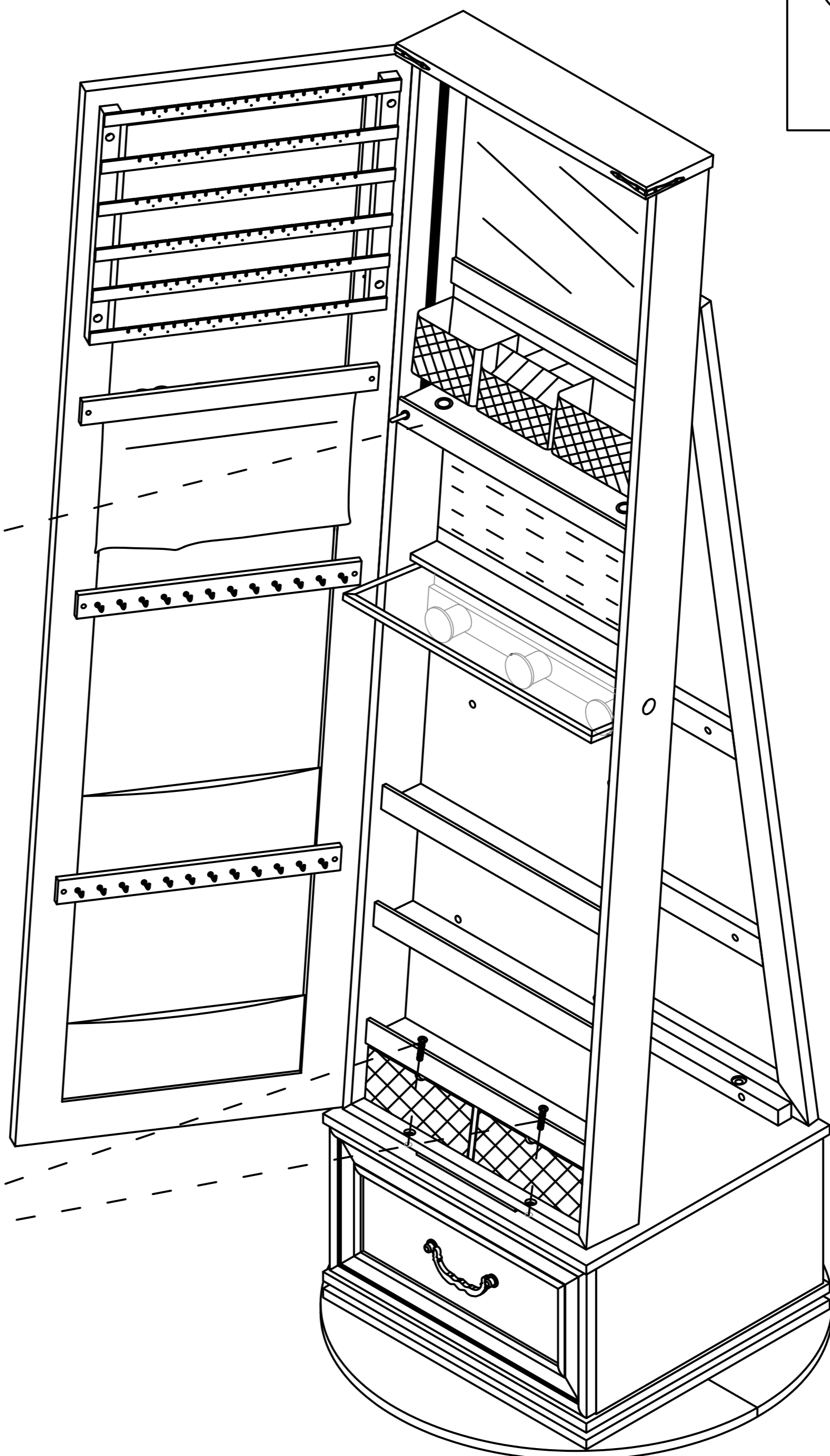
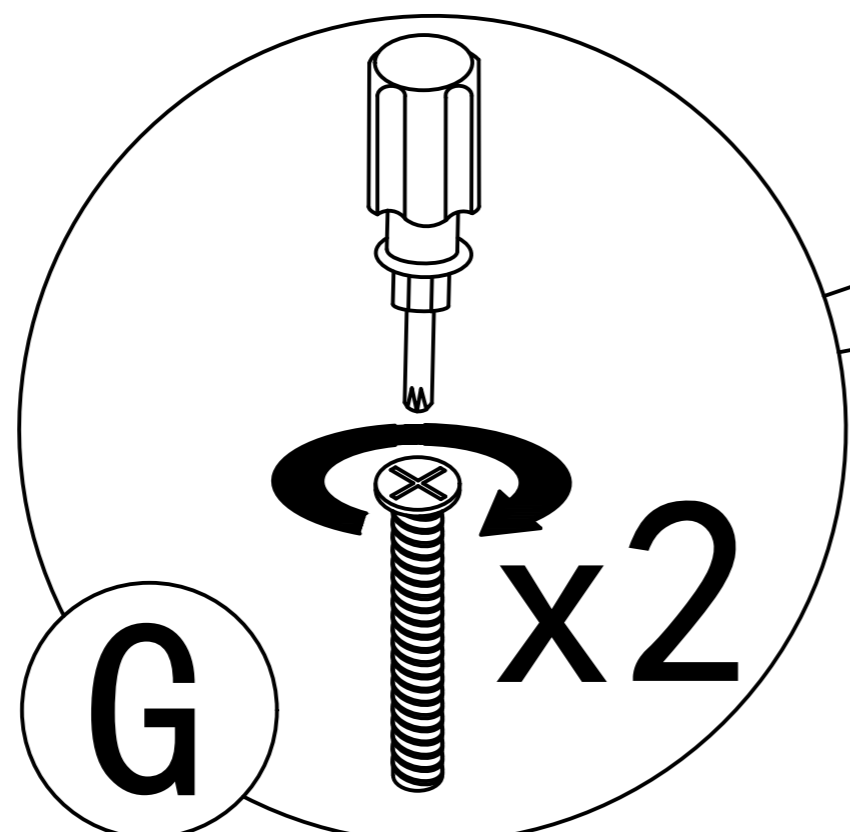
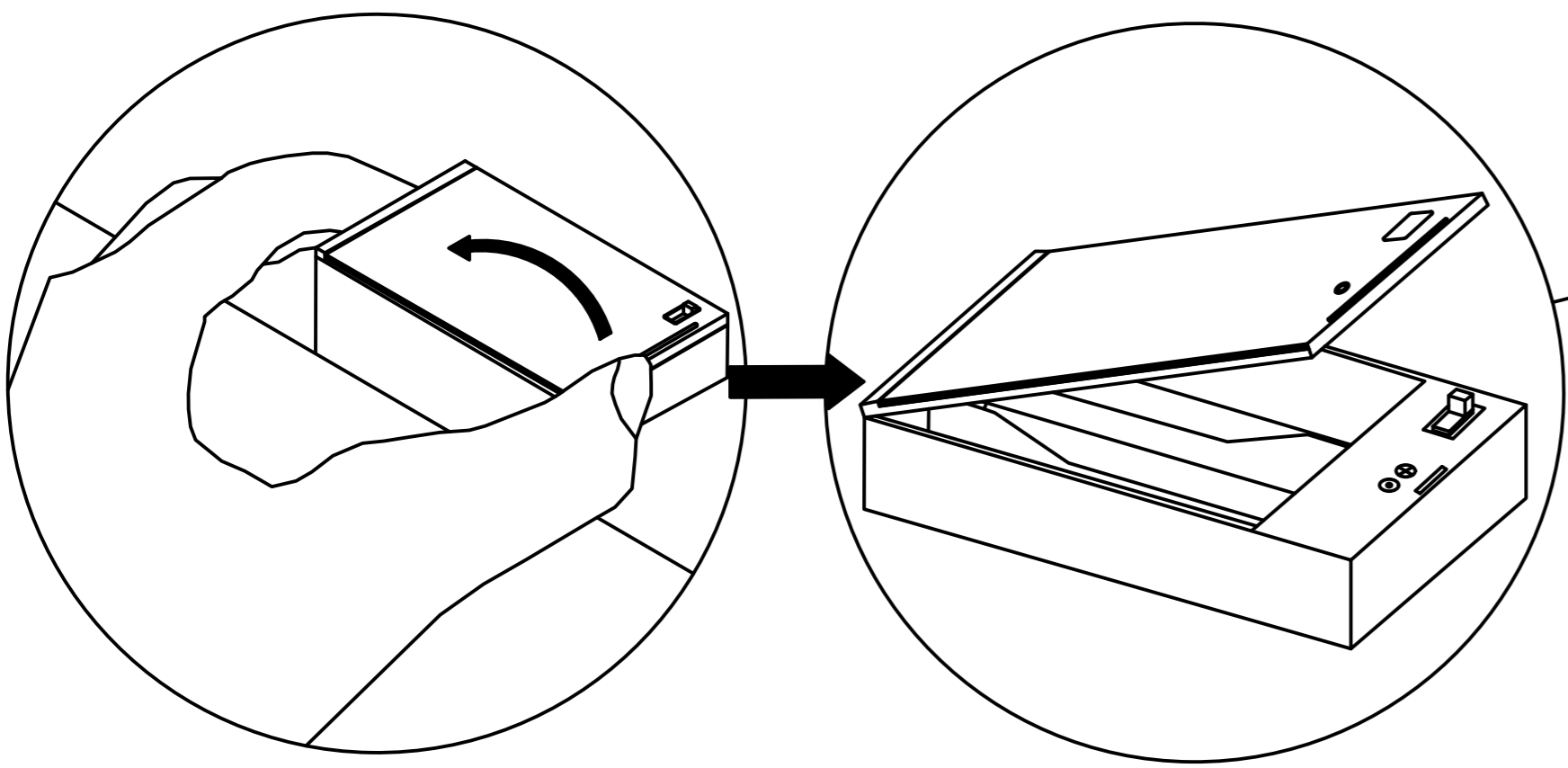

x2

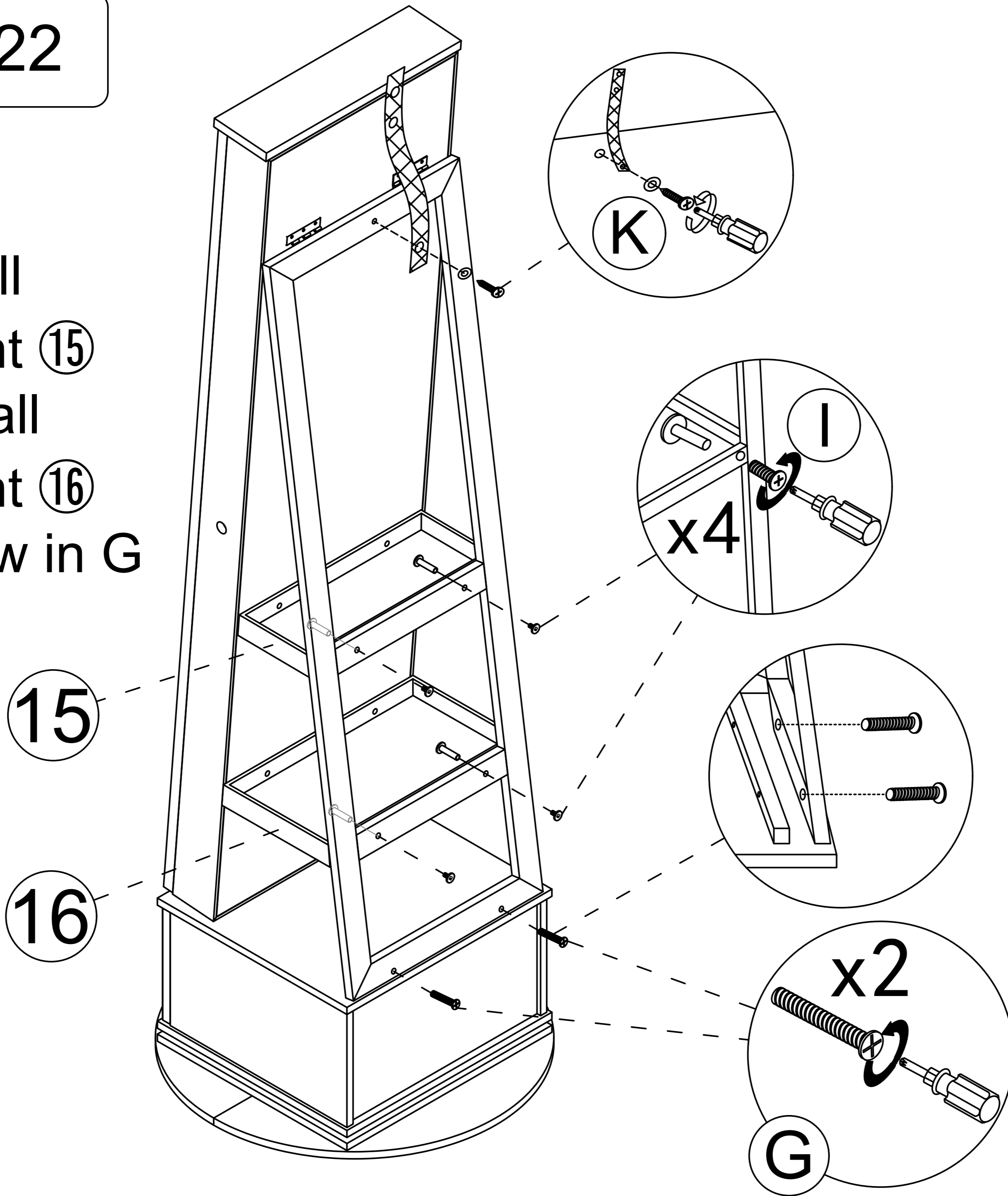

# Step 22

Order:  
 (1) First Install  
 Compartment ⑮  
 (2) Then Install  
 Compartment ⑯  
 (3) Last Screw in G

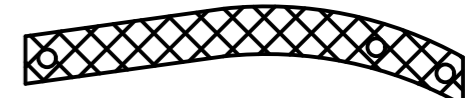

- ① G  x2
- ① I  (5\*20mm) x4
- ① K  x1  x1  
 x1

# Step 23

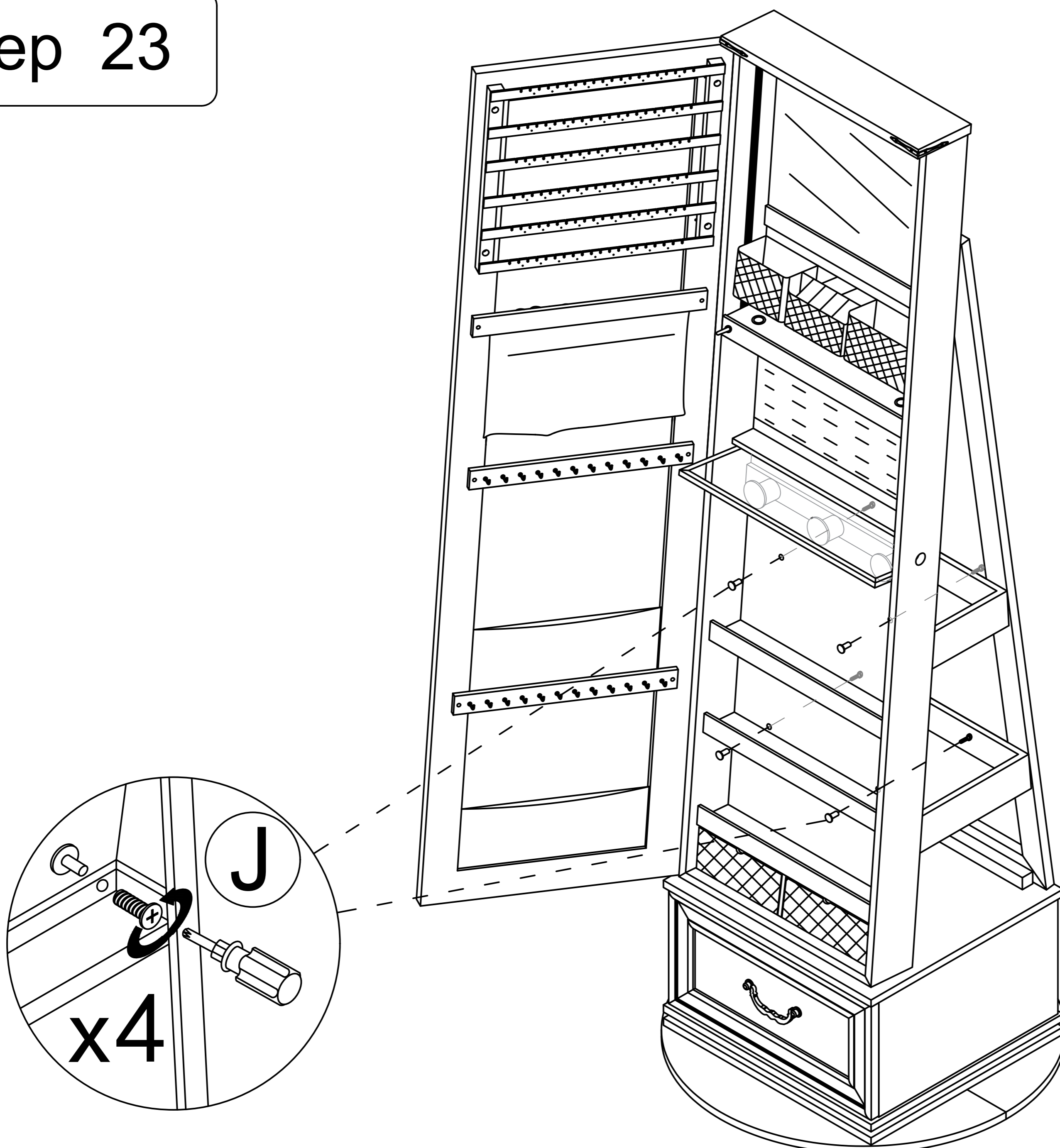

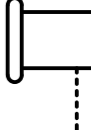
- ① J  (5\*10mm) x4

# Step 24

