

D Gebrauchsanweisung

NL Gebruiksrichtlijnen

IT Istruzioni per l'uso

CZ Pokyny k použití

HU Használati útmutató

PT Instruções de utilização

SK Pokyny k použitiu

GB Instructions for use

FR Instructions d'utilisation

PL Instrukcja obsługi

ES Instrucciones de empleo

RO Instrucțiuni de folosire

RU Инструкция по монтажу

TR Kullanım talimatları

Please check that you have all the parts listed before you start assembling, if you do find that something is missing, do not continue assembly, please contact us immediately.

NOTE: Please do not completely tighten all the hardware until the entire assembly is complete!

Bitte überprüfen Sie, ob alle Teile mitgeliefert sind, bevor Sie mit der Montage beginnen. Wenn Sie festlegen, dass etwas fehlt, setzen Sie die Montage nicht fort. Bitte kontaktieren Sie uns sofort.

Achtung: Bitte ziehen Sie nicht alle Schrauben fest, bevor die Montage abgeschlossen ist!

This set will be shipped by 2 boxes and they may arrive on different days. If both packages arrived but parts missing, please contact customer service.

Dieses Set ist in 2 Boxen enthalten. Wenn Sie keine vollen 2 Boxen erhalten, wenden Sie sich bitte an unseren Kundenservice

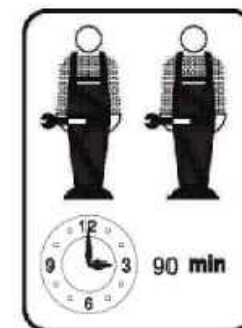

English

IMPORTANT FOR GAS LIFT BEDS&MAINTAINCE

- Please place the mattress on top of the bed frame.
- Please do not pull on the strap handles.
- Please press heavily to release the compressed gas.
- Periodically check all screw & fixings to ensure they are secure.
- When moving your product, carefully lift into place.
- Wipe clean with a slightly damp cloth- please do not use abrasive chemicals or bleach.
- Do NOT allow children to operate the lift mechanism.
- Do NOT allow children near the lift base when operating the mechanism.
- Do NOT stand inside the bed or the internal storage base.
- Do NOT overload the internal storage base.
- DO NOT jump on the product or any of its parts.

Deutsch

WICHTIG FÜR GASLIFT-BETTEN&WARTUNG

- Bitte legen Sie die Matratze oben auf den Bettrahmen.
- Bitte ziehen Sie nicht an den Gurtgriffen.
- Bitte drücken Sie kräftig, um das komprimierte Gas freizusetzen.
- Überprüfen Sie regelmäßig alle Schrauben und Befestigungen, um sicherzustellen, dass sie sicher sind.
- Wenn Sie Ihr Produkt bewegen, heben Sie es vorsichtig an seinen Platz.
- Mit einem leicht feuchten Tuch abwischen - bitte keine scheuernden Chemikalien oder Bleichmittel verwenden.
- Erlauben Sie Kindern NICHT, den Hebemechanismus zu bedienen.
- Lassen Sie Kinder NICHT in die Nähe des Liftsockels, wenn Sie den Mechanismus bedienen.
- Stellen Sie sich NICHT in das Bett oder in die Innenablage.
- Überlasten Sie den internen Liftsockel NICHT.
- Springen Sie NICHT auf das Produkt oder eines seiner Teile.

Français

IMPORTANT POUR LES LITS À RELEVAGE DE GAZ&MAINTENANCE

- Veuillez placer le matelas sur le dessus du cadre de lit.
- Ne tirez pas sur les poignées de la sangle.
- Appuyez fortement pour libérer le gaz comprimé.
- Vérifiez régulièrement que toutes les vis et fixations sont bien en place.
- Lorsque vous déplacez votre produit, soulevez-le avec précaution pour le mettre en place.
- Nettoyez avec un chiffon légèrement humide - n'utilisez pas de produits chimiques abrasifs ou d'eau de Javel.
- Ne laissez pas les enfants utiliser le mécanisme de levage.
- Ne laissez pas les enfants s'approcher de la base de levage lorsqu'ils actionnent le mécanisme.
- Ne vous tenez PAS à l'intérieur du lit ou de la base de stockage interne.
- Ne surchargez pas la base de stockage interne.
- Ne pas sauter sur le produit ou l'une de ses parties.

Italiano

IMPORTANTE PER I LETTI CON SOLLEVAMENTO A GAS E LA MANUTENZIONE

- Posizionare il materasso sopra la struttura del letto.
- Non tirare le maniglie della cinghia.
- Premere con forza per rilasciare il gas compresso.
- Controllare periodicamente tutte le viti e i fissaggi per assicurarsi che siano saldi.
- Quando si sposta il prodotto, sollevarlo con cautela.
- Pulire con un panno leggermente umido, senza usare prodotti chimici abrasivi o candeggina.
- NON permettere ai bambini di azionare il meccanismo di sollevamento.
- NON permettere ai bambini di avvicinarsi alla base di sollevamento quando si aziona il meccanismo.
- NON sostare all'interno del letto o della base di contenimento interna.
- NON sovraccaricare la base di contenimento interna.
- NON saltare sul prodotto o sulle sue parti.

- Coloque el colchón sobre el somier.
- No tire de las asas de la correa.
- Presione con fuerza para liberar el gas comprimido.
- Compruebe periódicamente que todos los tornillos y fijaciones estén bien sujetos.
- Al mover el producto, levántelo con cuidado para colocarlo en su sitio.
- Limpie con un paño ligeramente humedecido; no utilice productos químicos abrasivos ni lejía.
- NO permita que los niños accionen el mecanismo de elevación.
- NO permita que los niños se acerquen a la base elevadora cuando accionen el mecanismo.
- NO se ponga de pie dentro de la cama o de la base de almacenamiento interna.
- NO sobrecargue el somier.
- NO salte sobre el producto ni sobre ninguna de sus piezas.

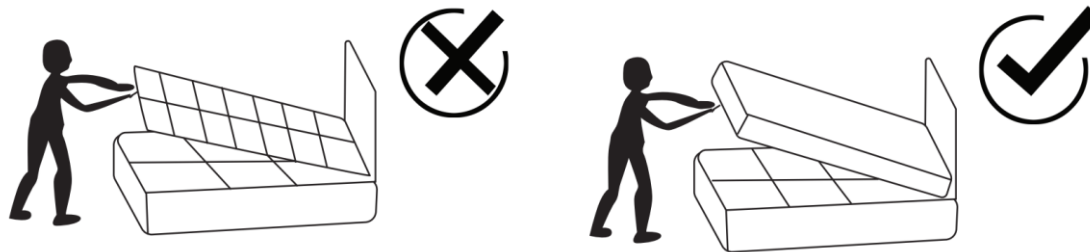

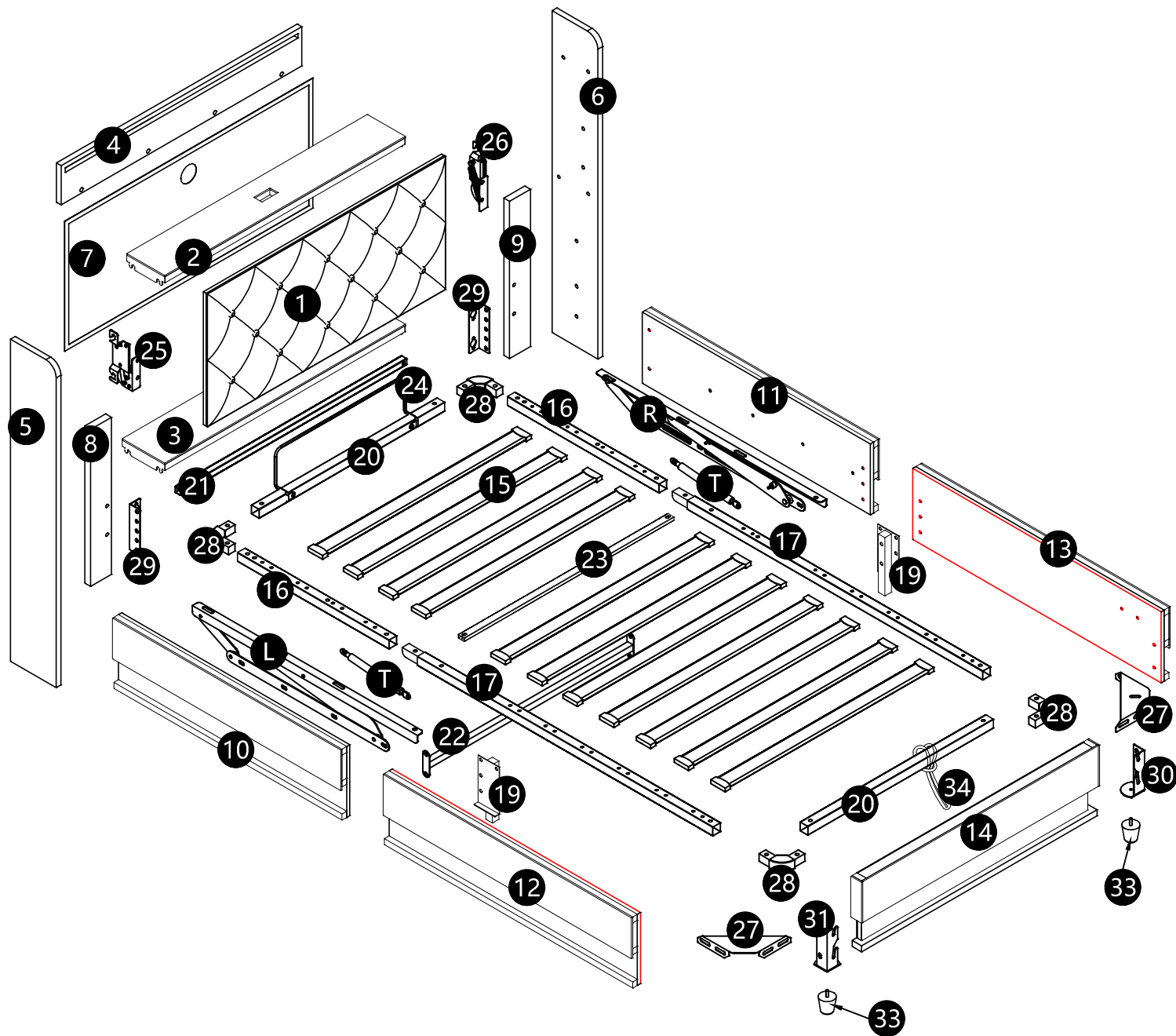



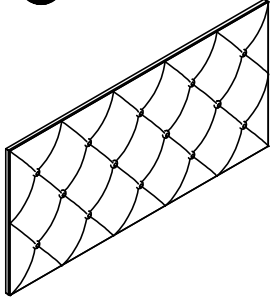
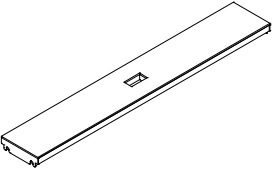
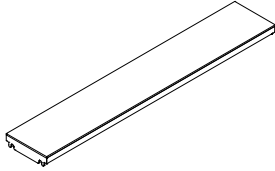
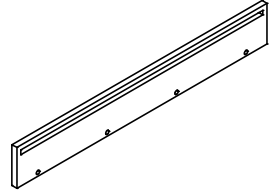
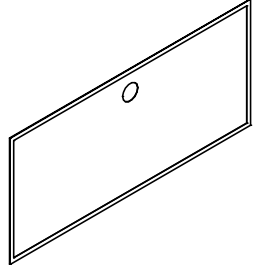
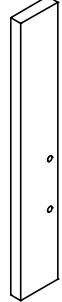
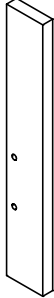
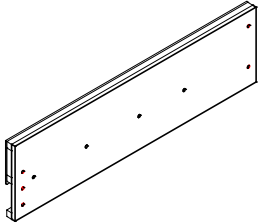
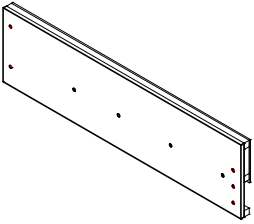
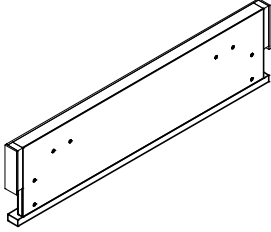
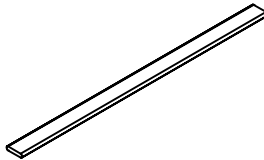
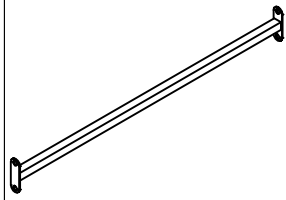
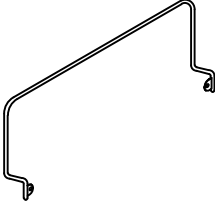
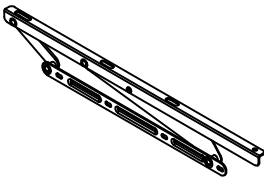
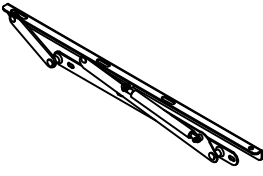
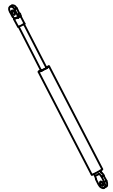

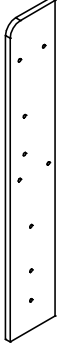
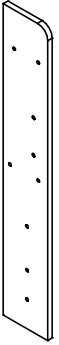
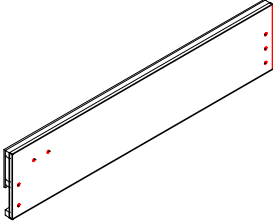
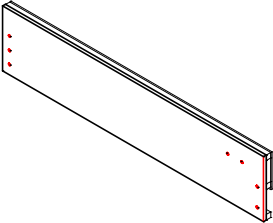
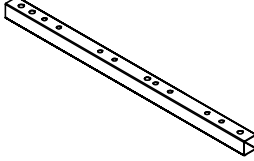
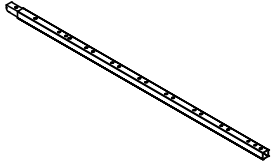
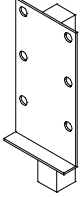
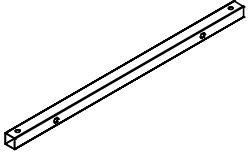
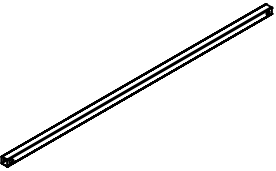
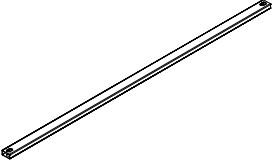

Part List

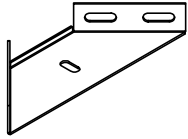
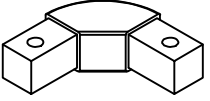
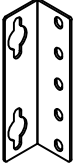
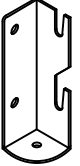
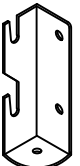
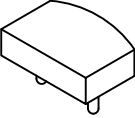
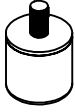
<p>1 x1</p> 	<p>2 x1</p> 	<p>3 x1</p> 	<p>4 x1</p> 	<p>7 x1</p> 	<p>8 x1</p> 	<p>9 x1</p> 
<p>10 x1</p> 	<p>11 x1</p> 	<p>14 x1</p> 	<p>15 x11</p> 	<p>22 x1</p> 	<p>24 x1</p> 	<p>L x1</p> 
<p>R x1</p> 	<p>T x2</p>  <p>400mm 9mm 650N</p>					

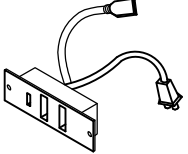



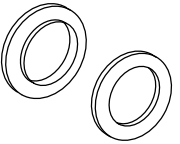
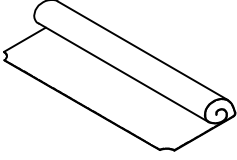
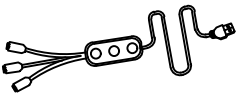
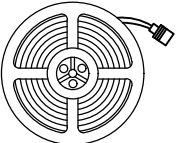





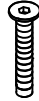
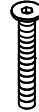

Part List

<p>5 x1</p> 	<p>6 x1</p> 	<p>12 x1</p> 	<p>13 x1</p> 	<p>16 x2</p> 	<p>17 x2</p> 	<p>19 x2</p> 
<p>20 x2</p> 	<p>21 x1</p> 	<p>23 x1</p> 	<p>25 x1</p> 	<p>26 x1</p> 	<p>27 x2</p> 	<p>28 x4</p> 
<p>29 x2</p> 	<p>30 x1</p> 	<p>31 x1</p> 	<p>32 x22+1</p> 	<p>33 x2</p> 	<p>34 x1</p> 	<p>35 x1</p> 

Part List

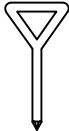
<p>36 x1</p> 	<p>37 x1</p> 	<p>39 x1</p>  <p>Power cord</p>	<p>41 x2</p>  <p>Light strip</p>	<p>42 x3</p>  <p>Strap magic tape</p>		

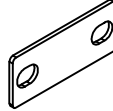
Hardware Parts

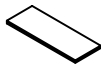
<p>A x4</p>  <p>M6*15</p>	<p>B x4</p>  <p>M6*30</p>	<p>C x13</p>  <p>M8*12</p>	<p>D x80</p>  <p>M8*20</p>	<p>E x2</p>  <p>M8*40</p>	<p>F x9</p>  <p>M8*45</p>	<p>G x12</p>  <p>M8</p>
<p>J x1</p>  <p>M6</p>	<p>K x1</p>  <p>M8</p>	<p>L x1</p> 	<p>M x3</p>  <p>M3*12</p>	<p>N x1</p> 	<p>O x2</p> 	<p>P x6</p> 
<p>Q x4</p>  <p>M6*φ12</p>	<p>S x4</p> 					

Step:1

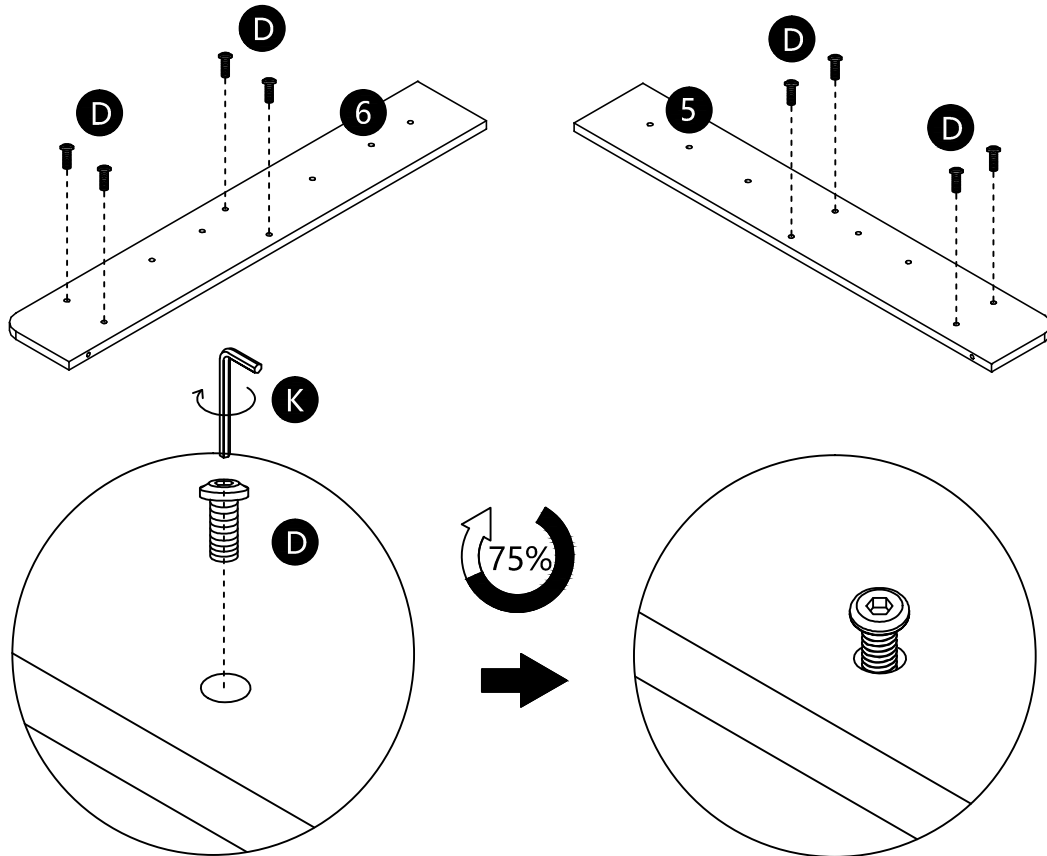

M8*20
D 8PCS

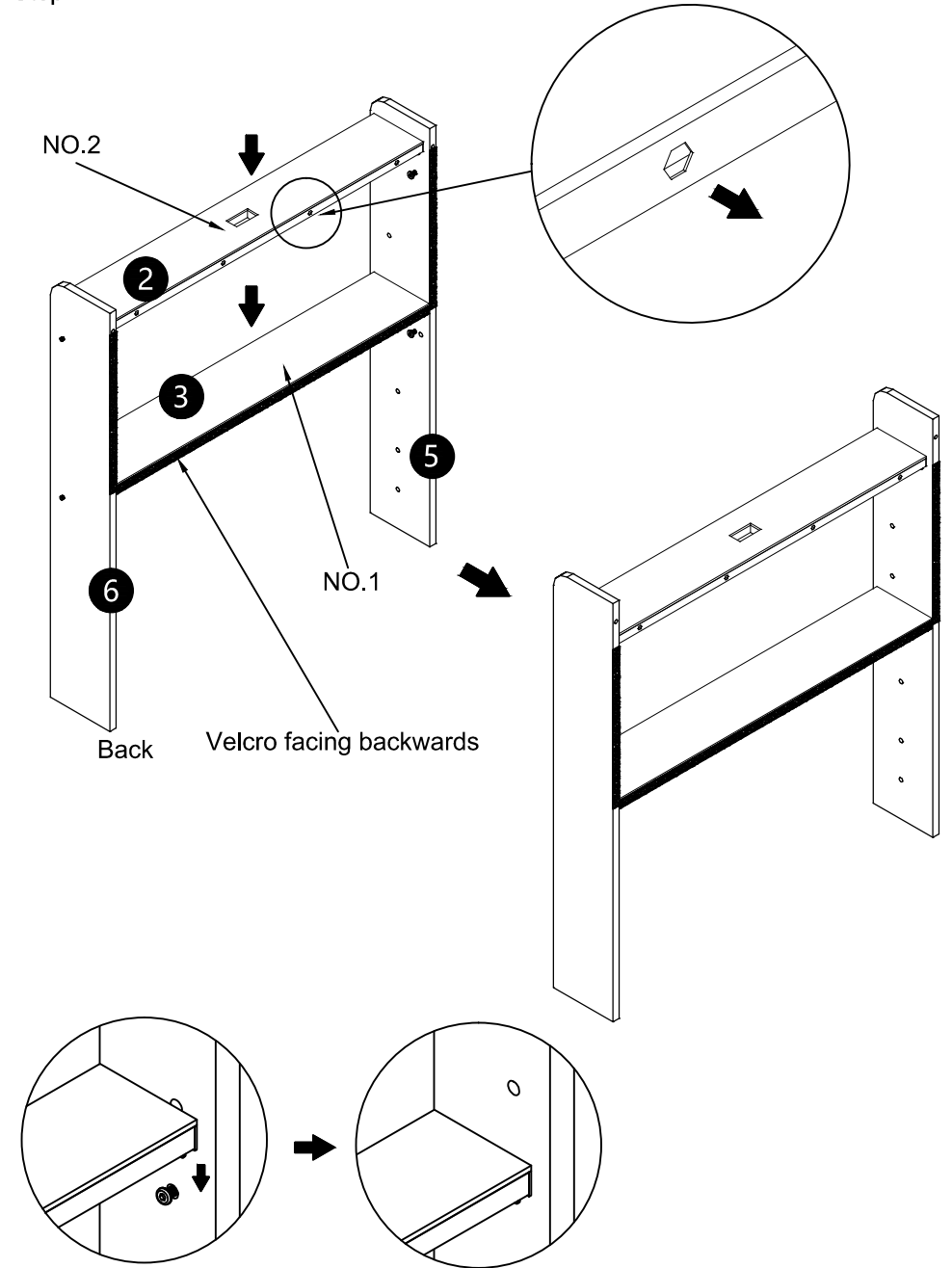

Step:2

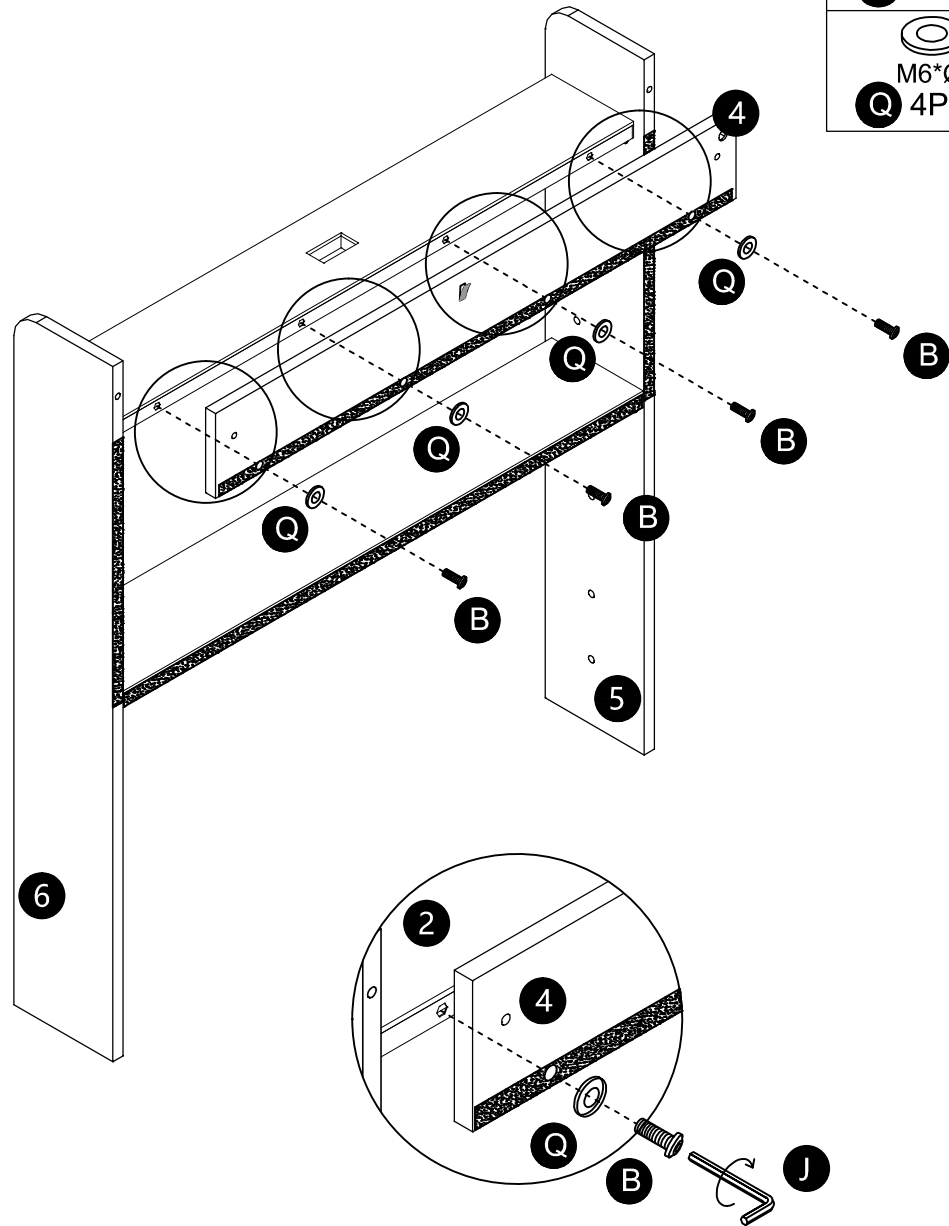

Step:3



Step:4

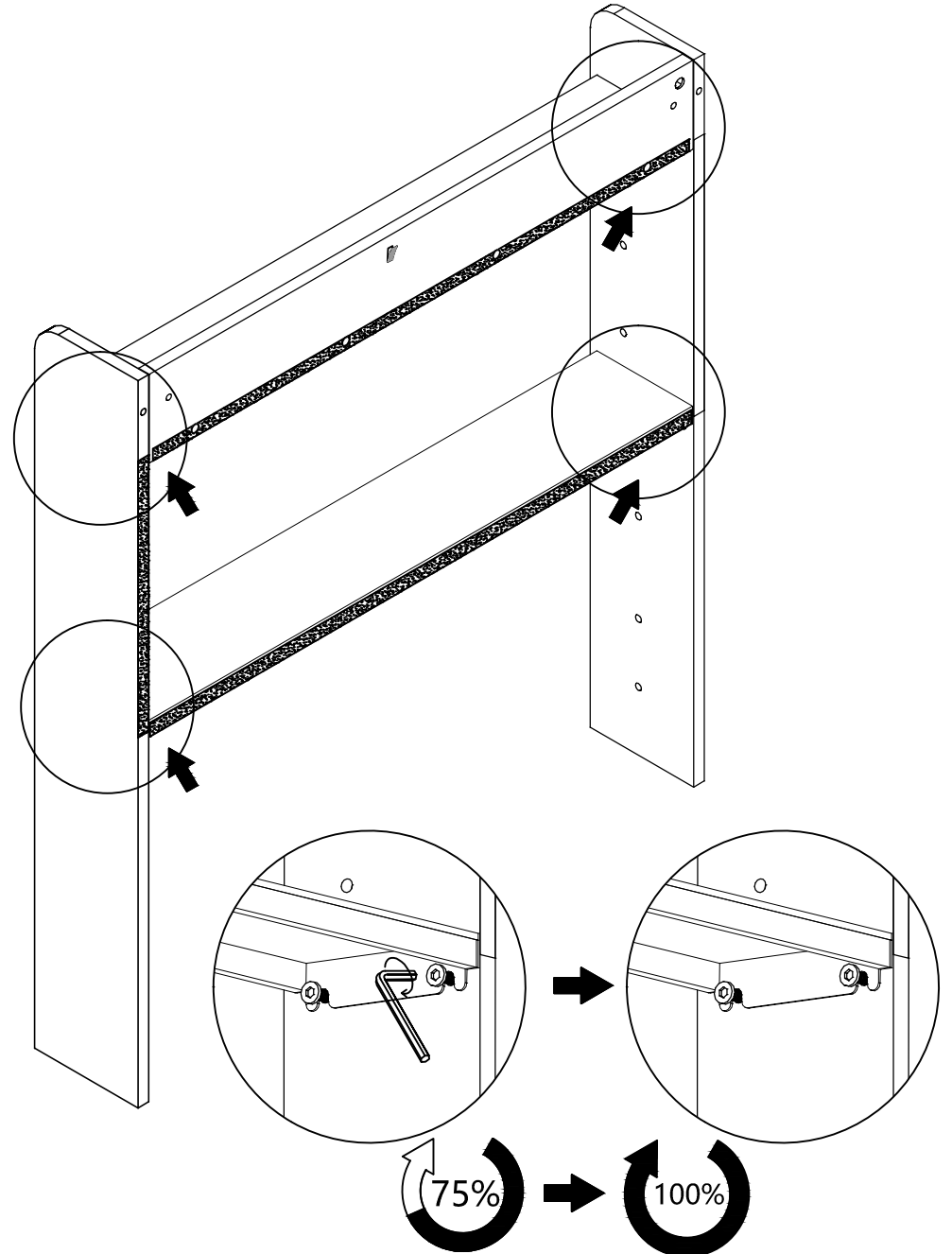

Step:7

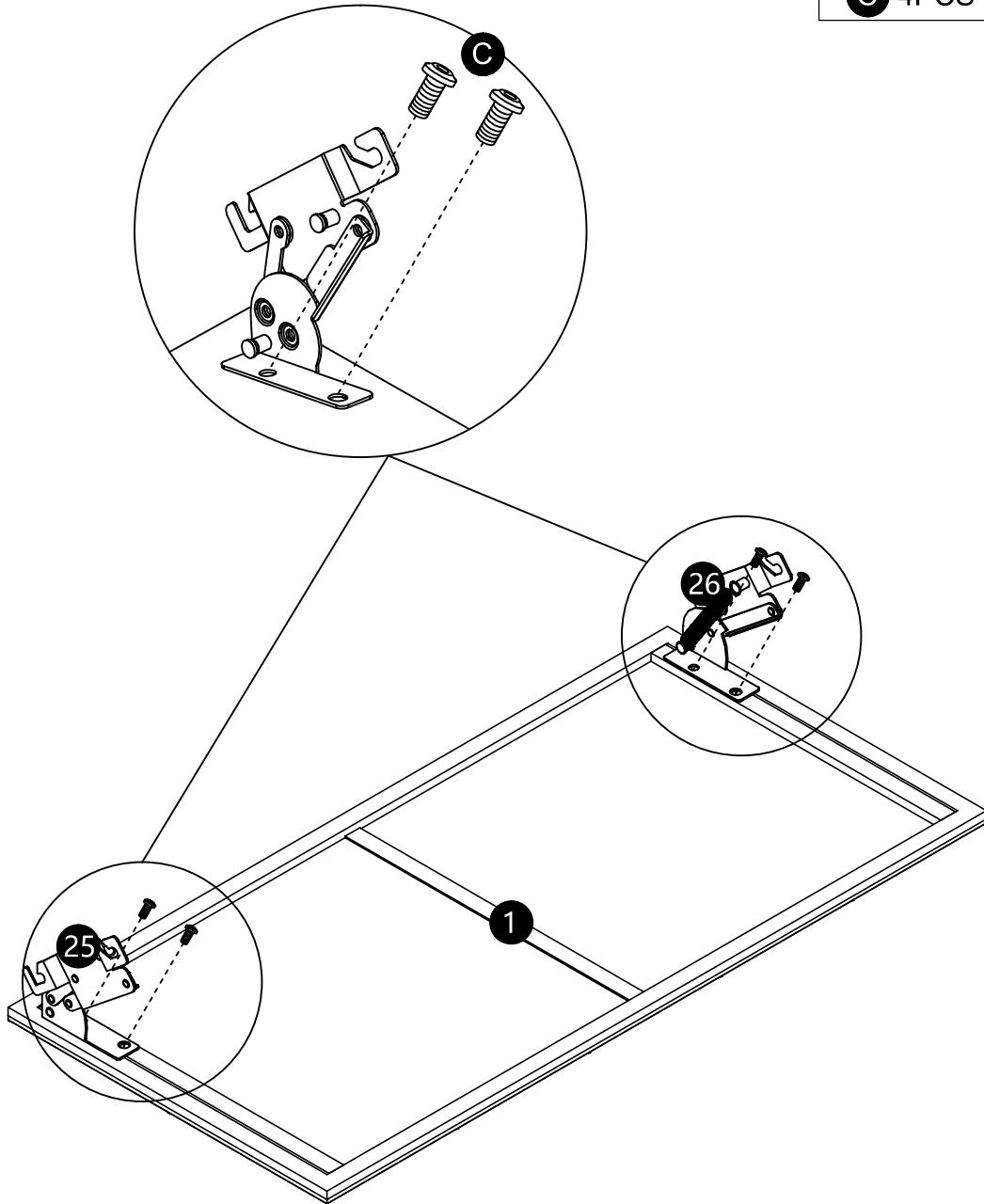

M8*12
C 4PCS

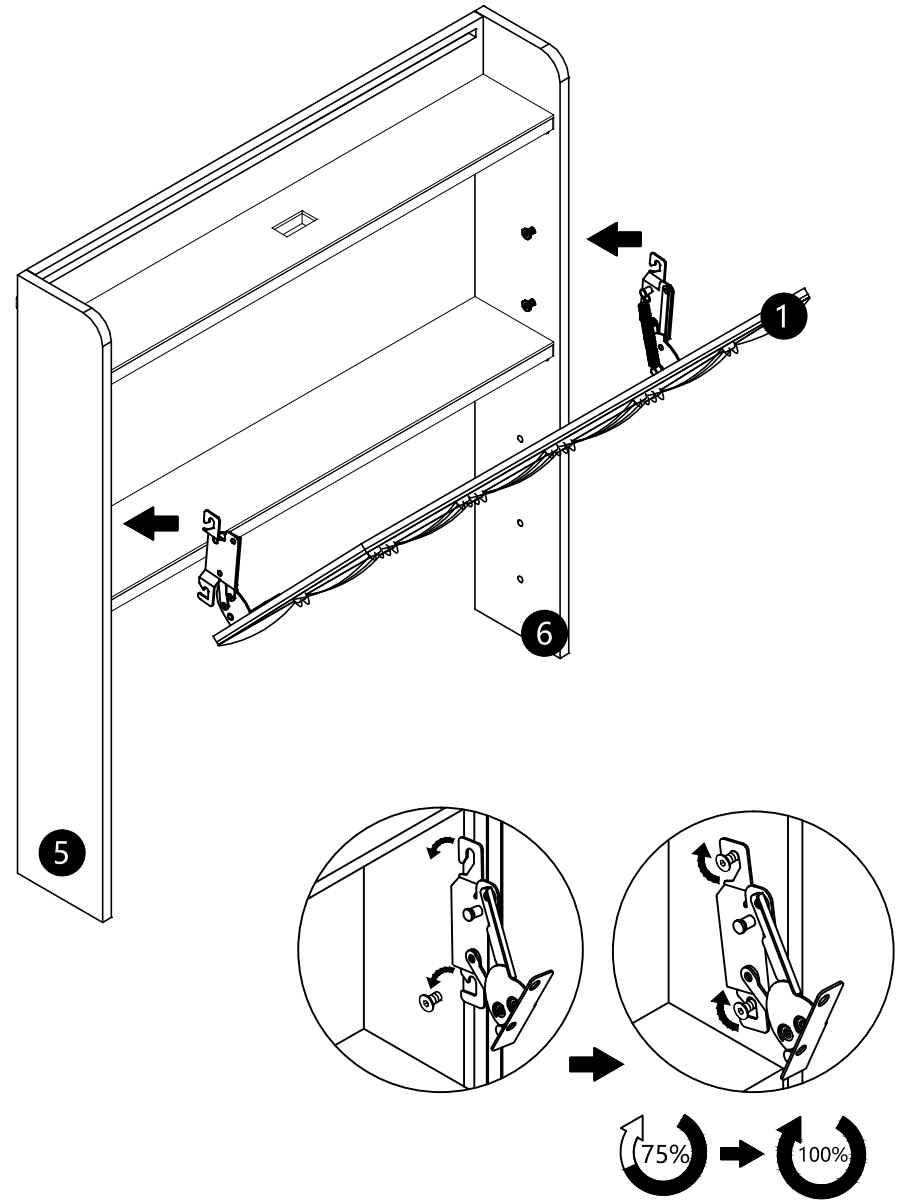

Step:8

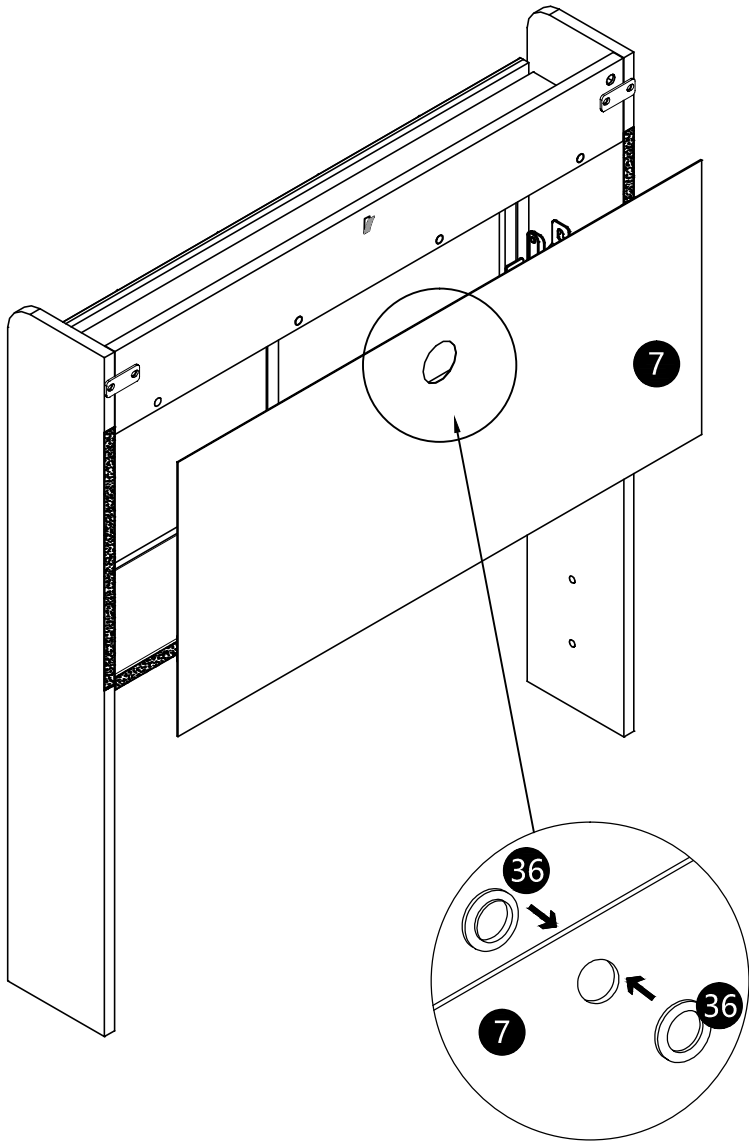

Step:9



Step:10

M8*20
D 6PCS

P 6PCS

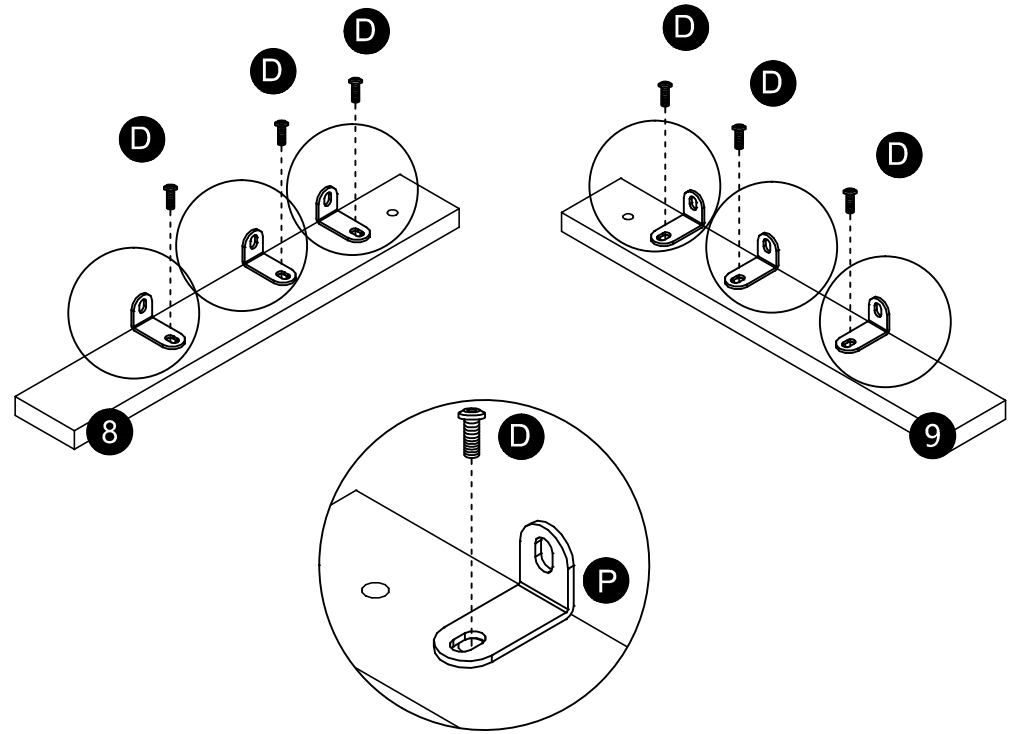

Step:11

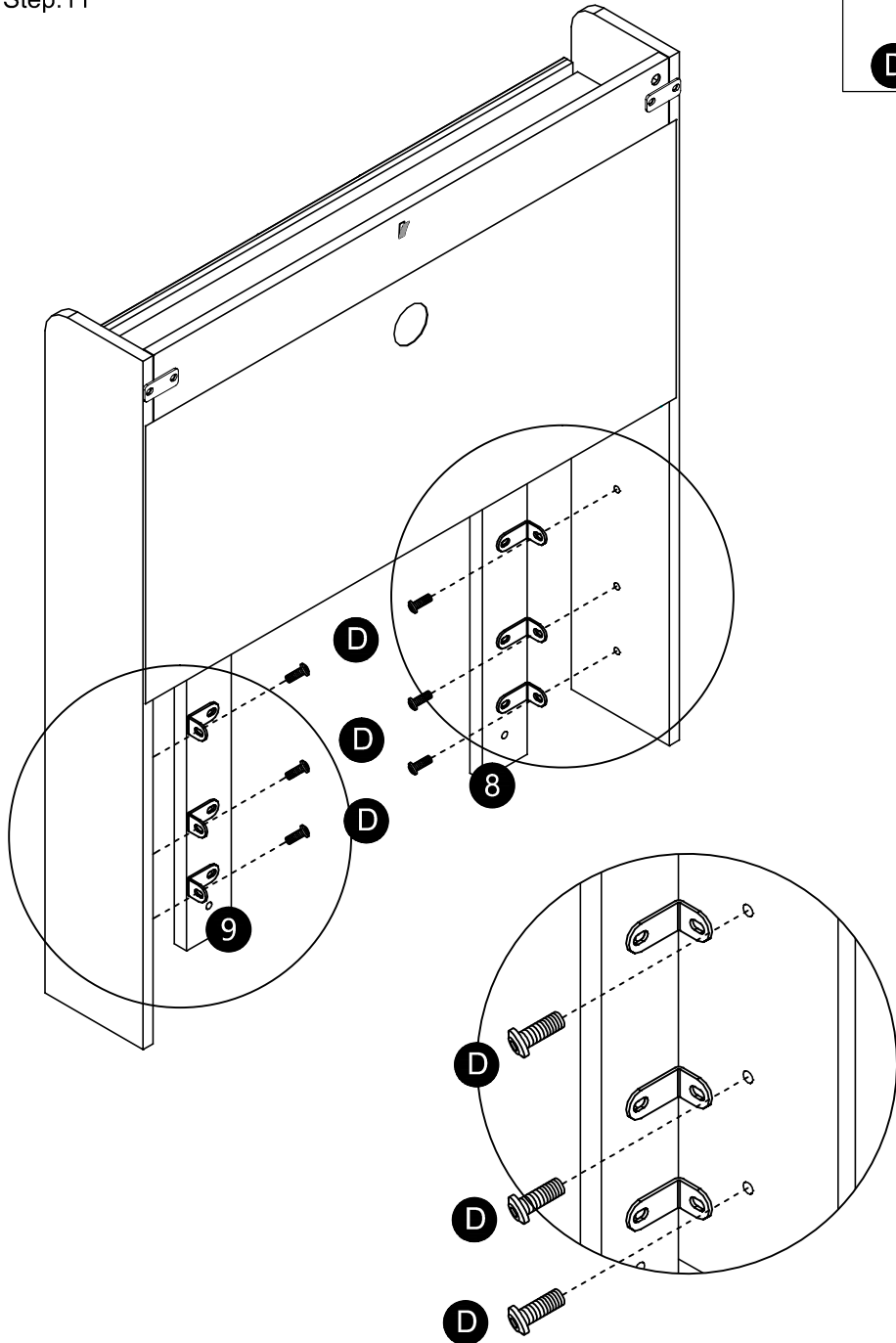

M8*20
D 6PCS

Step:12

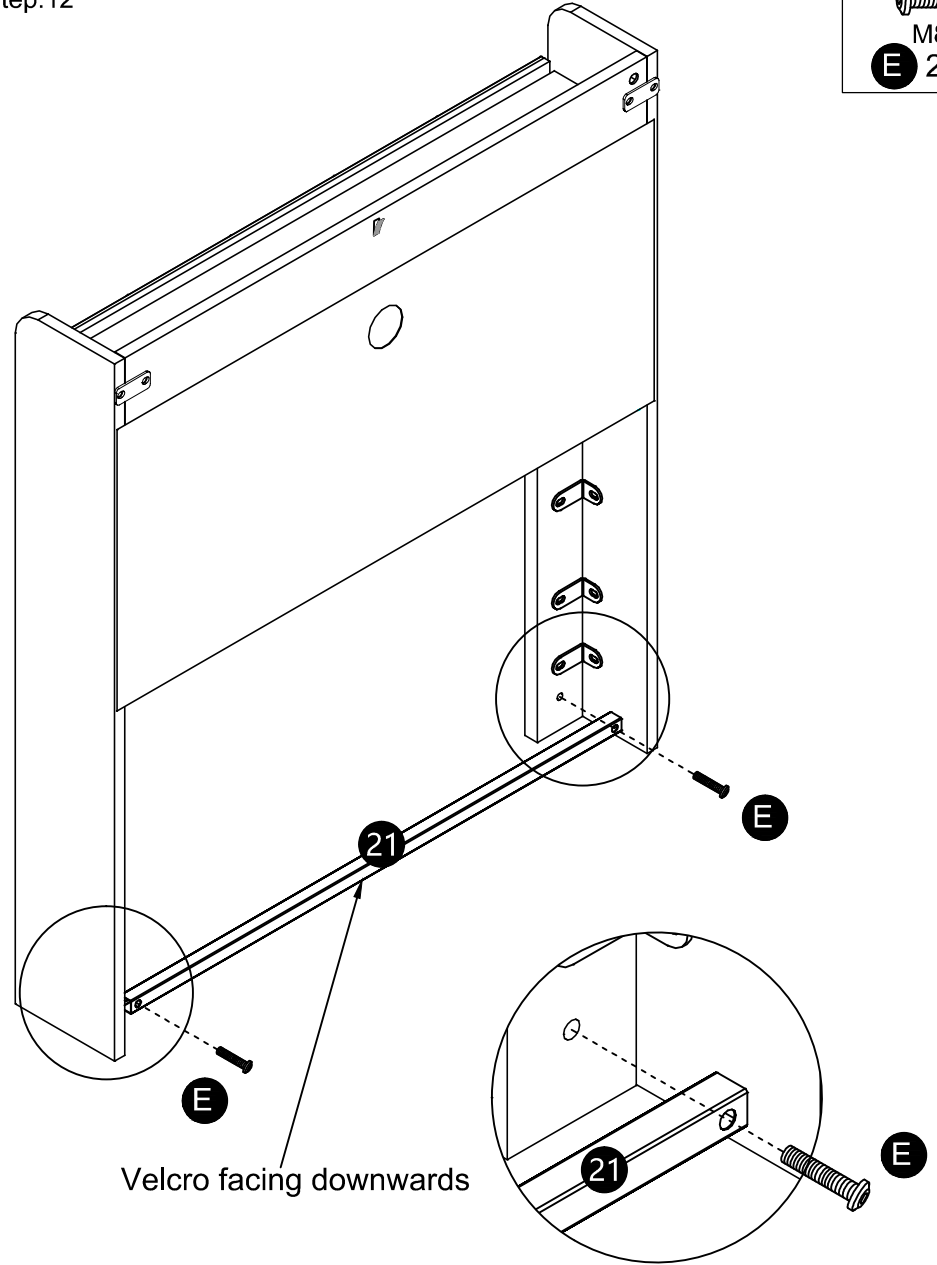

M8*40
E 2PCS

Velcro facing downwards

Step:13

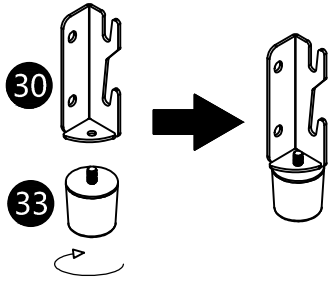

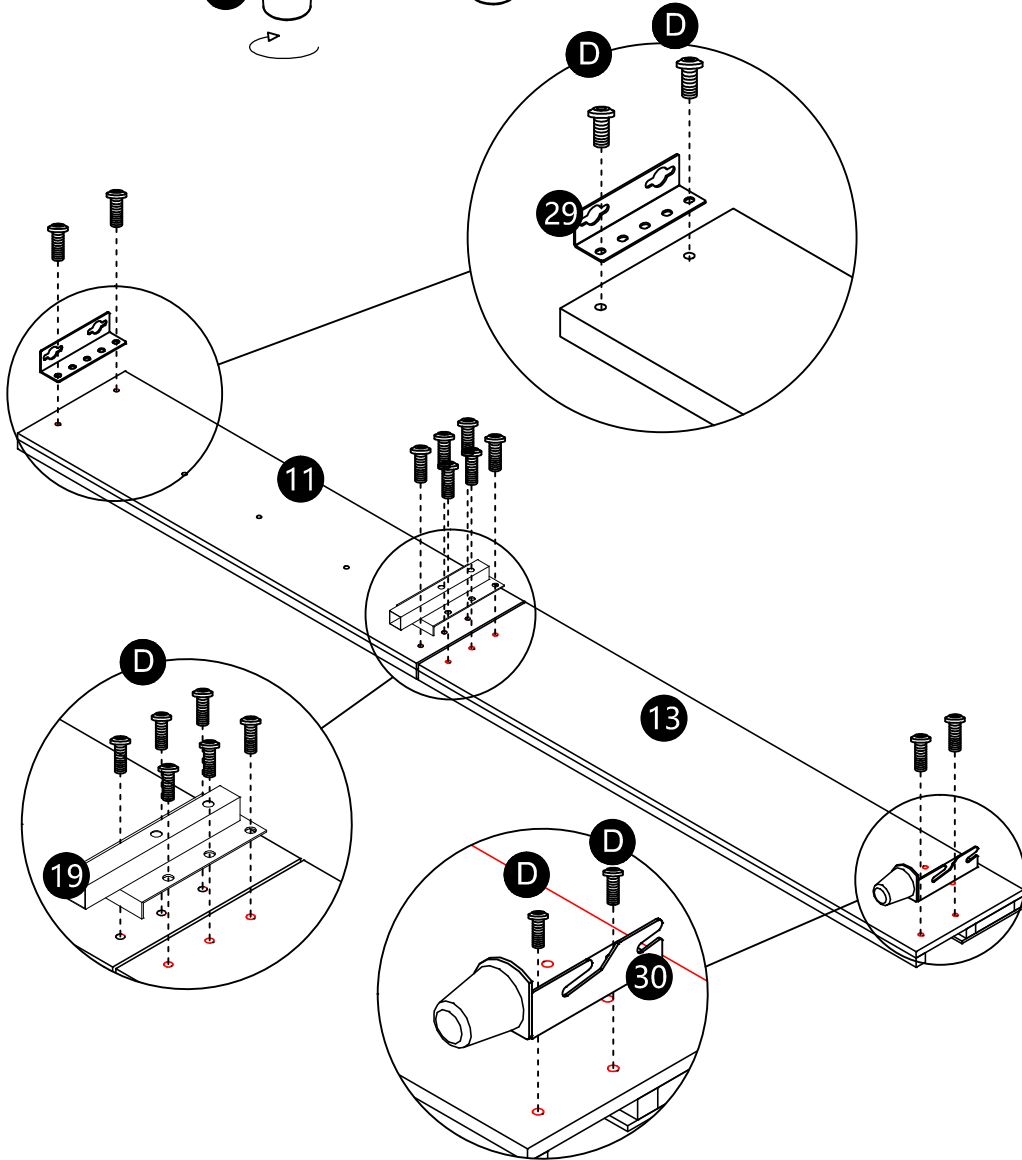

M8*20
D 10PCS

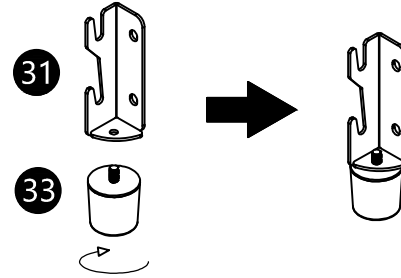

Step:14



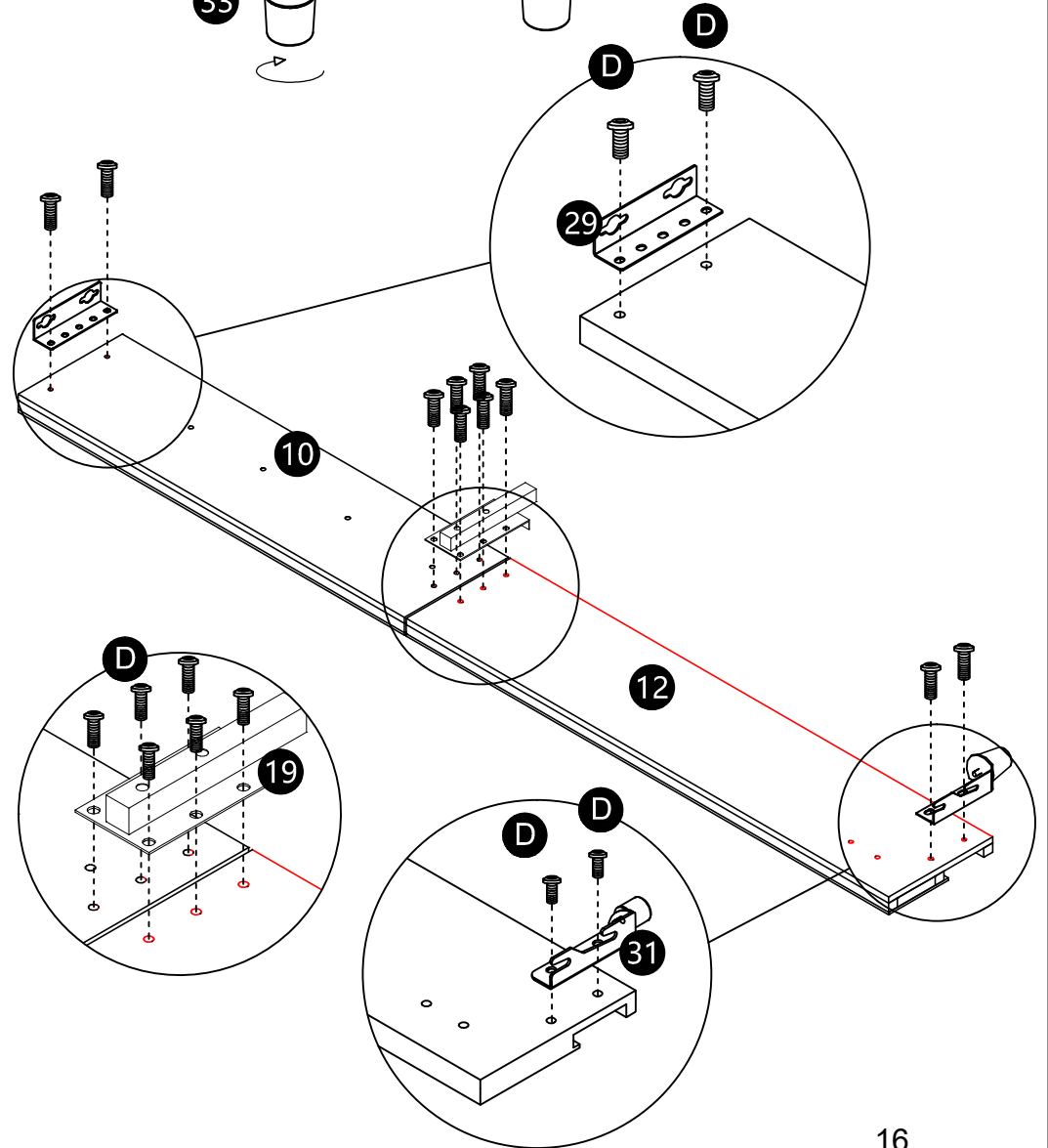

M8*20
D 10PCS

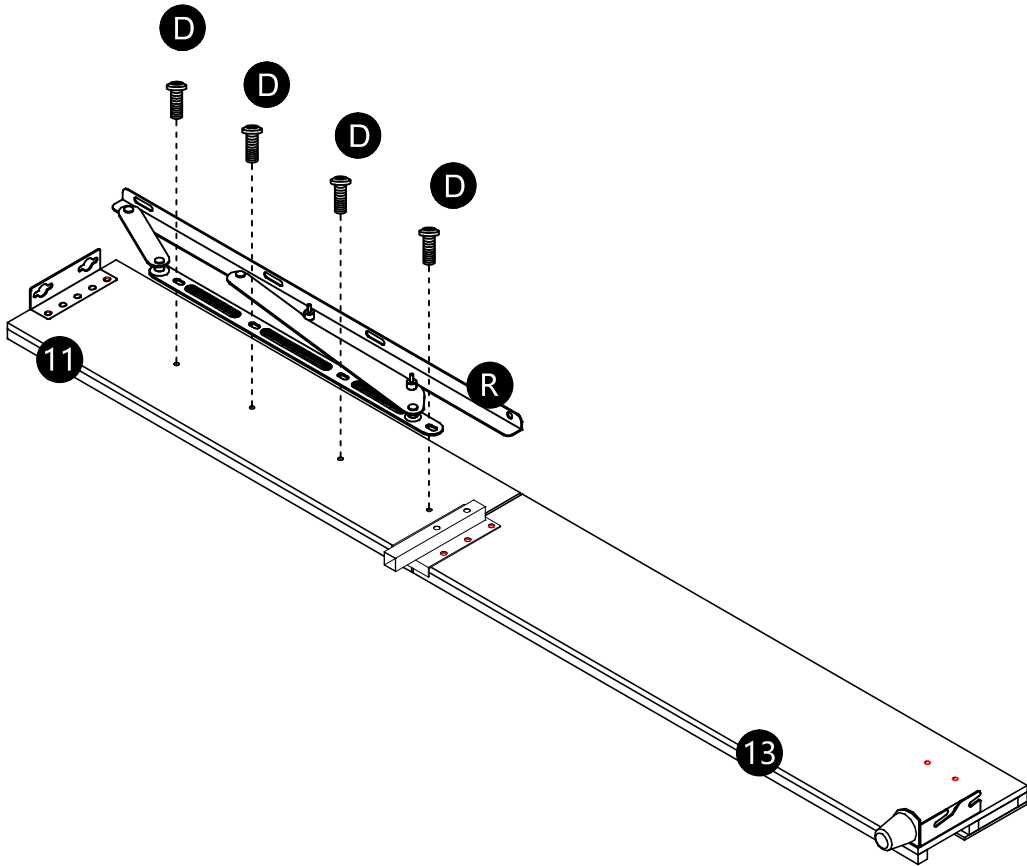

Step:15

M8*20
D 4PCS



Step:16

M8*20
D 4PCS

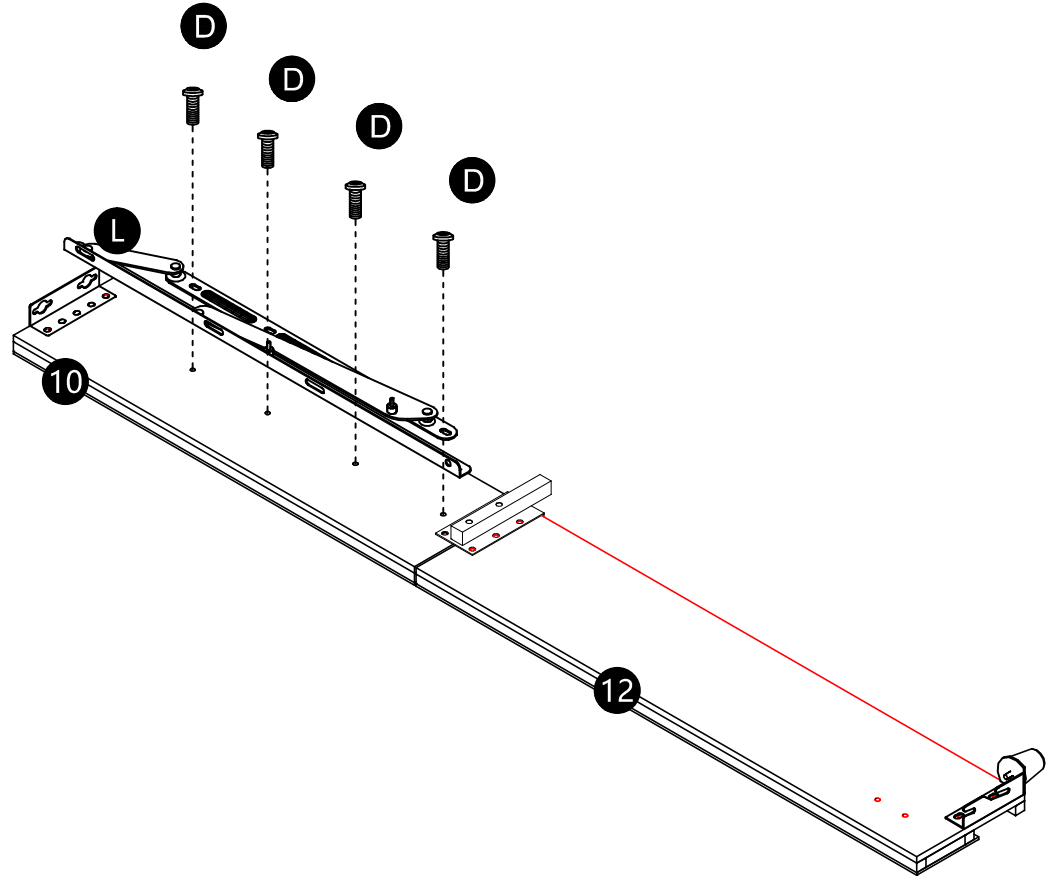

Step:17

M8*20
D 4PCS

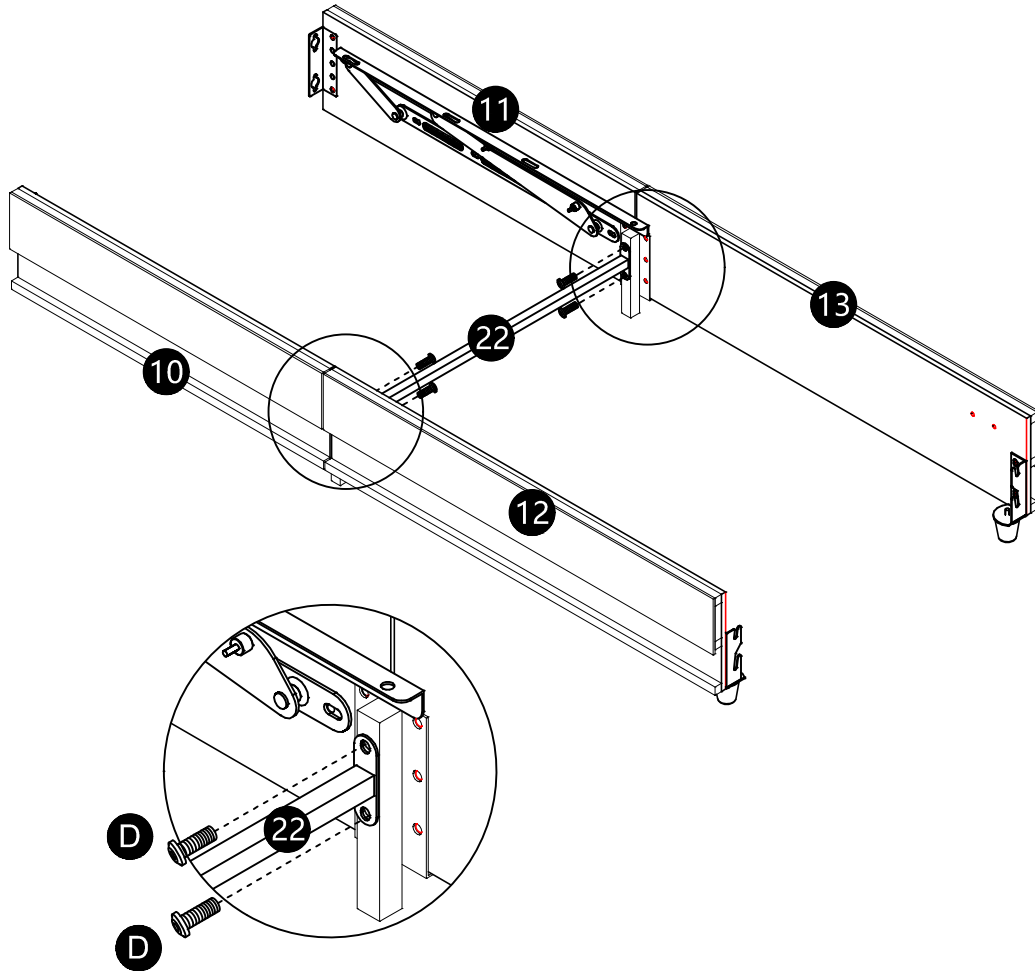

Step:18

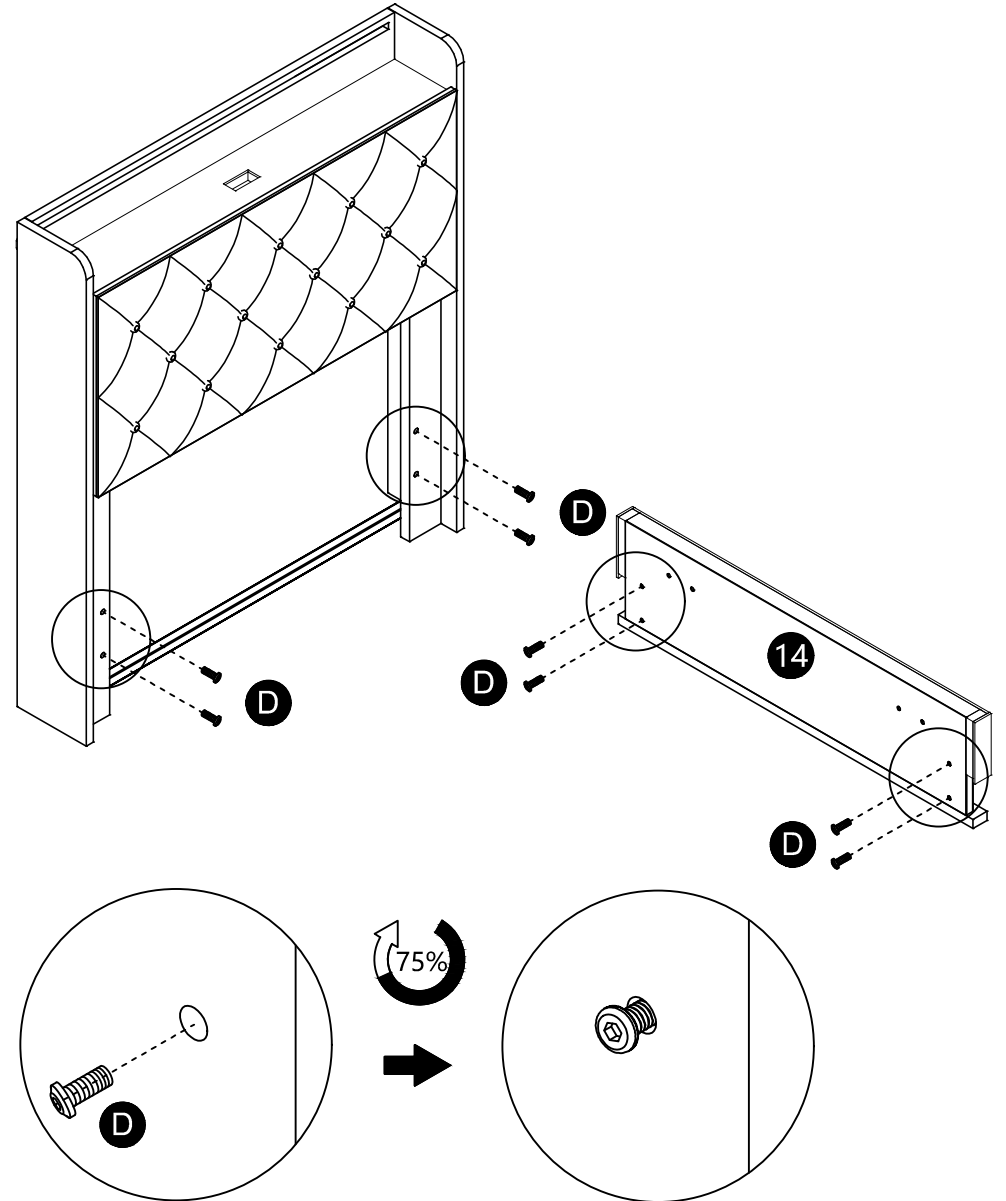

M8*20
D 8PCS

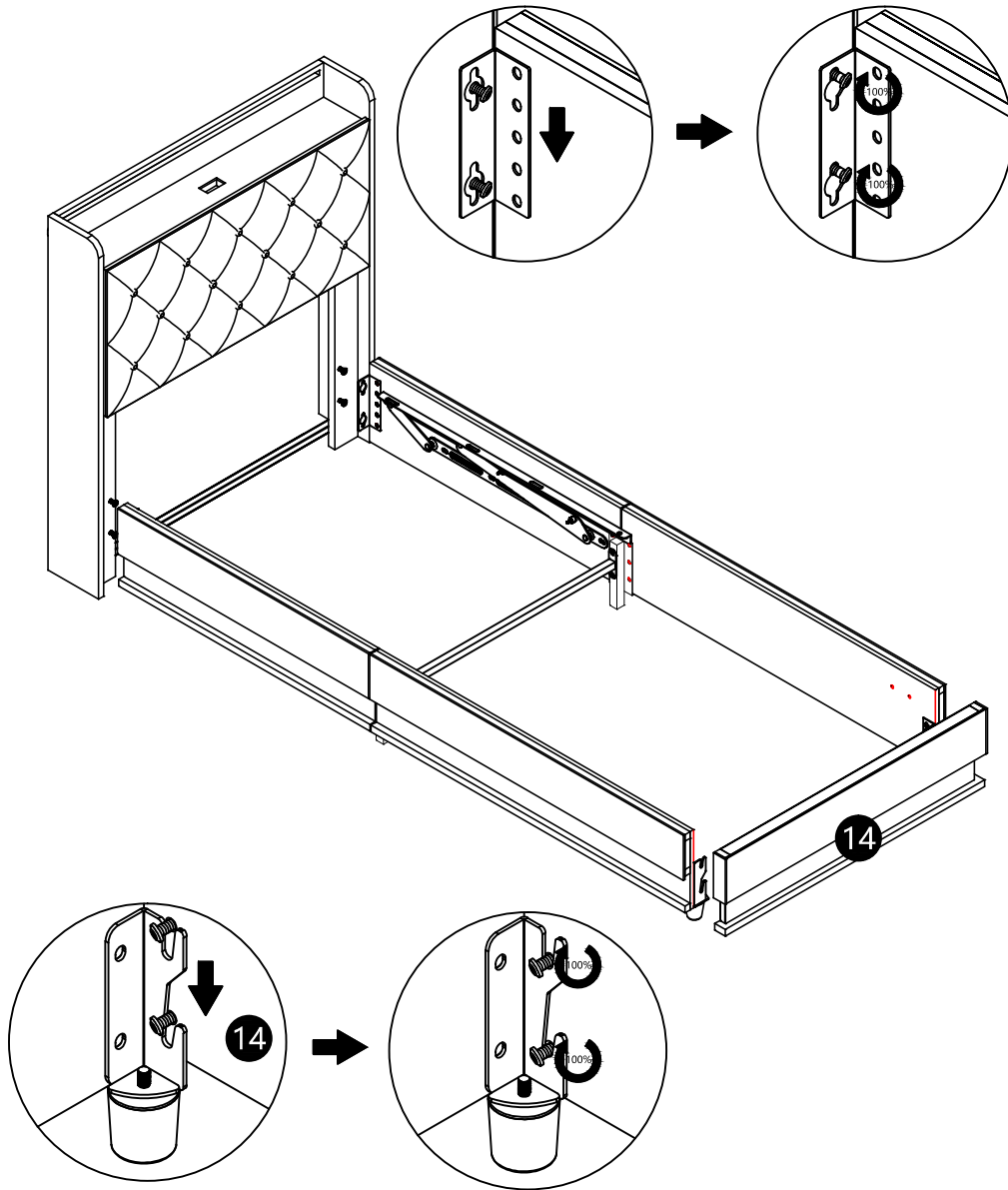

Step:19

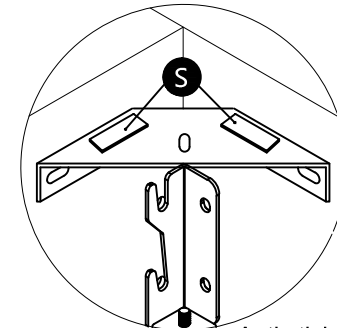
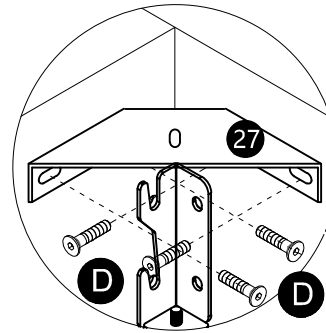

Step:20



M8*20
D 8PCS

S 4PCS

Anti stick
paper



silent sticker

Silent sticker

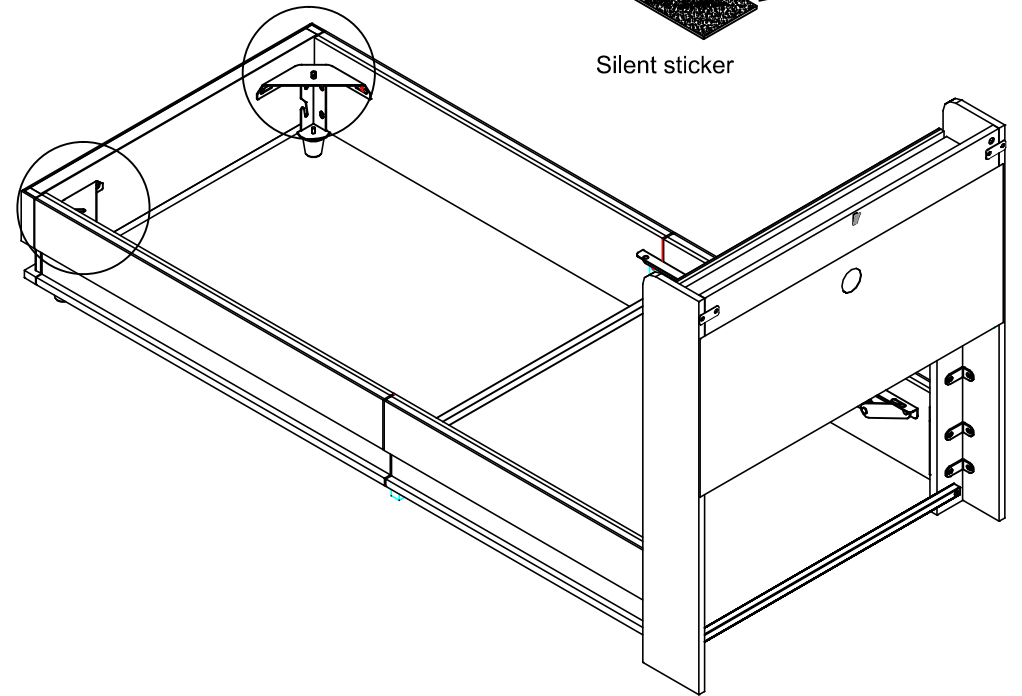

Step:21

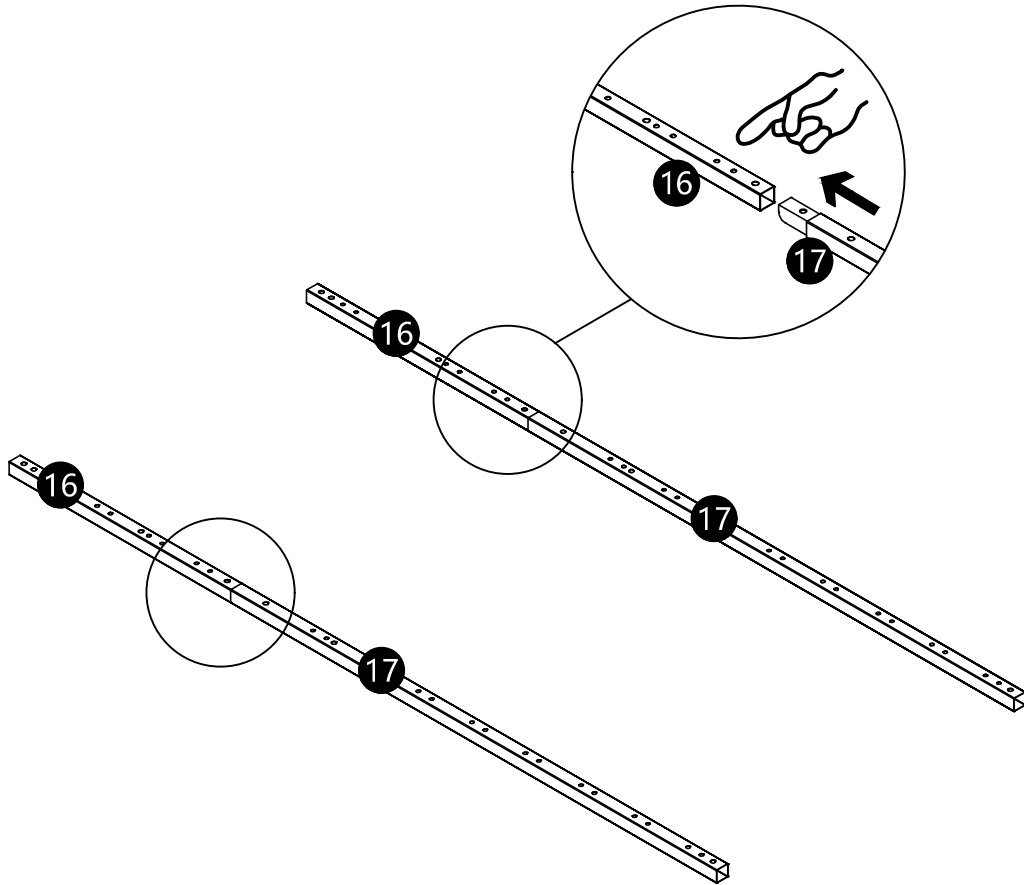

Step:22

M8*12
C 8PCS

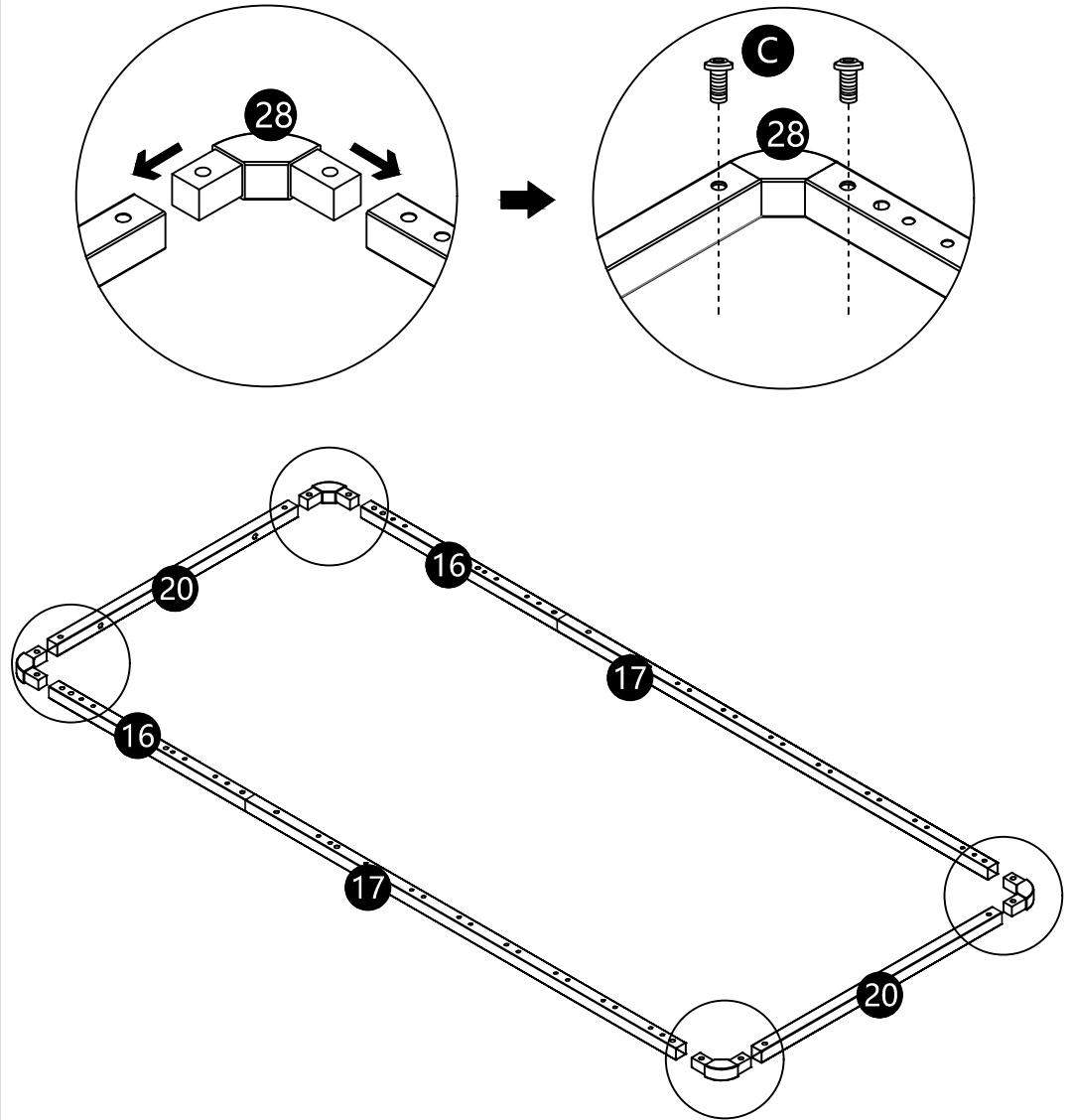

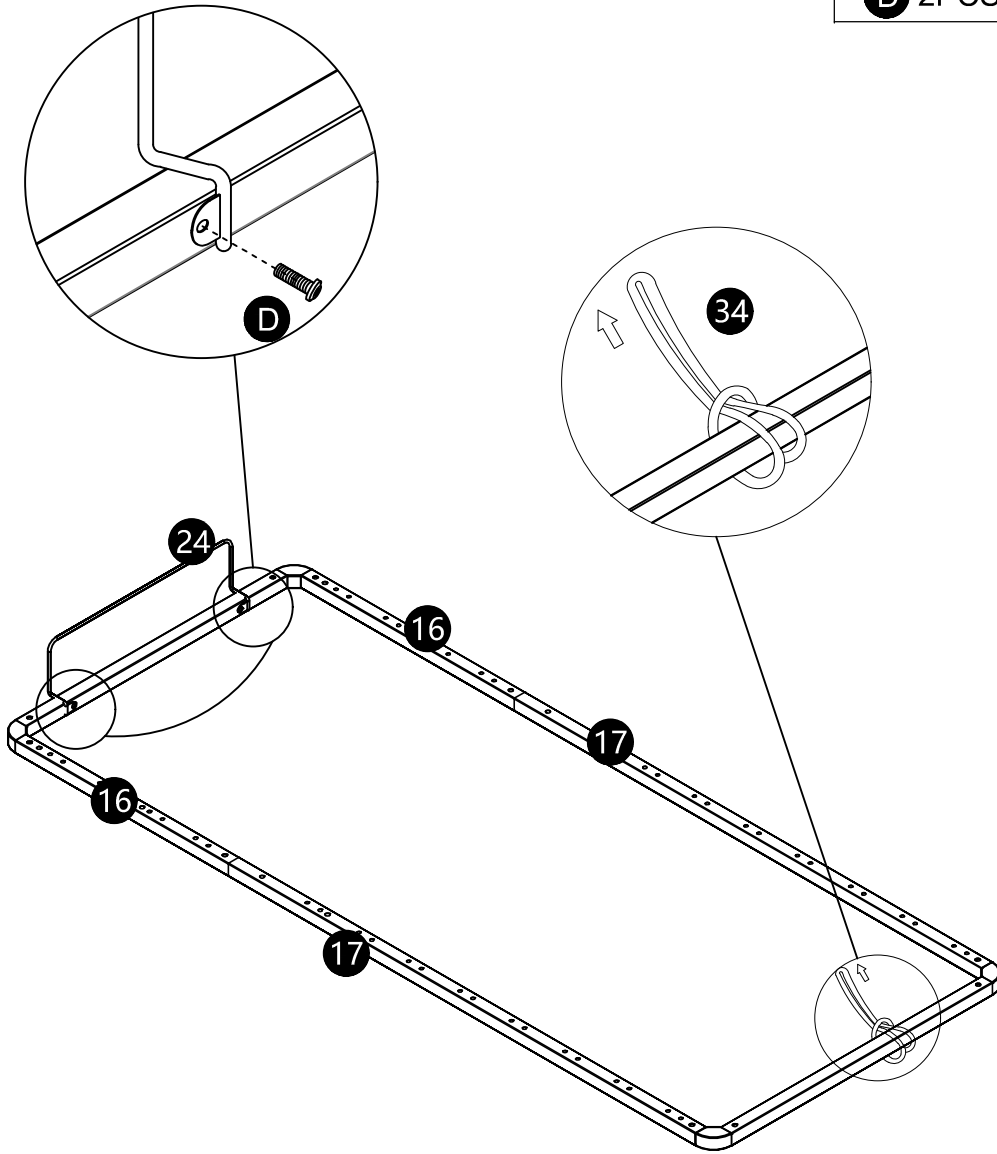

Step:23

M8*20
D 2PCS



Step:24

M8*45
F 2PCS

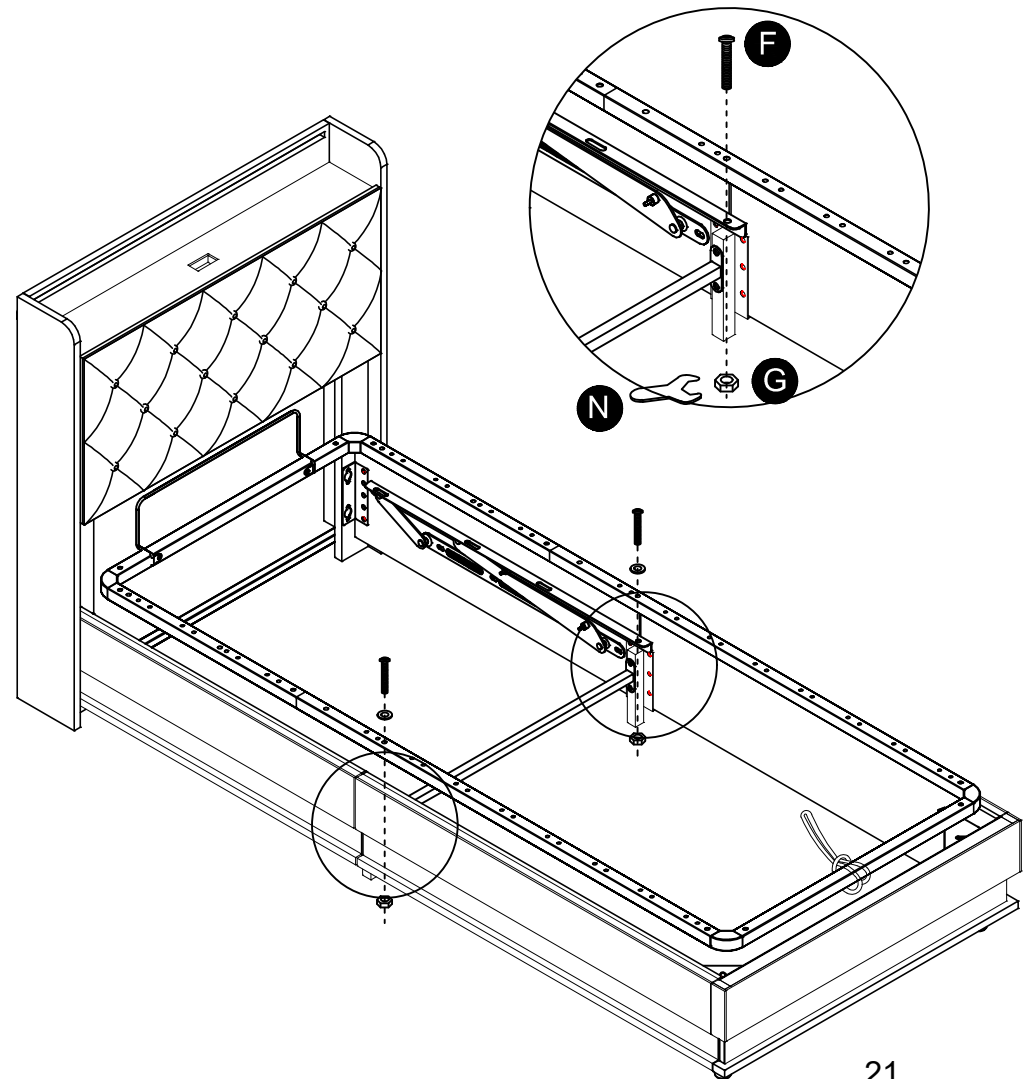
M8
G 2PCS



Step:25



M8*45
F 6PCS

M8
G 6PCS

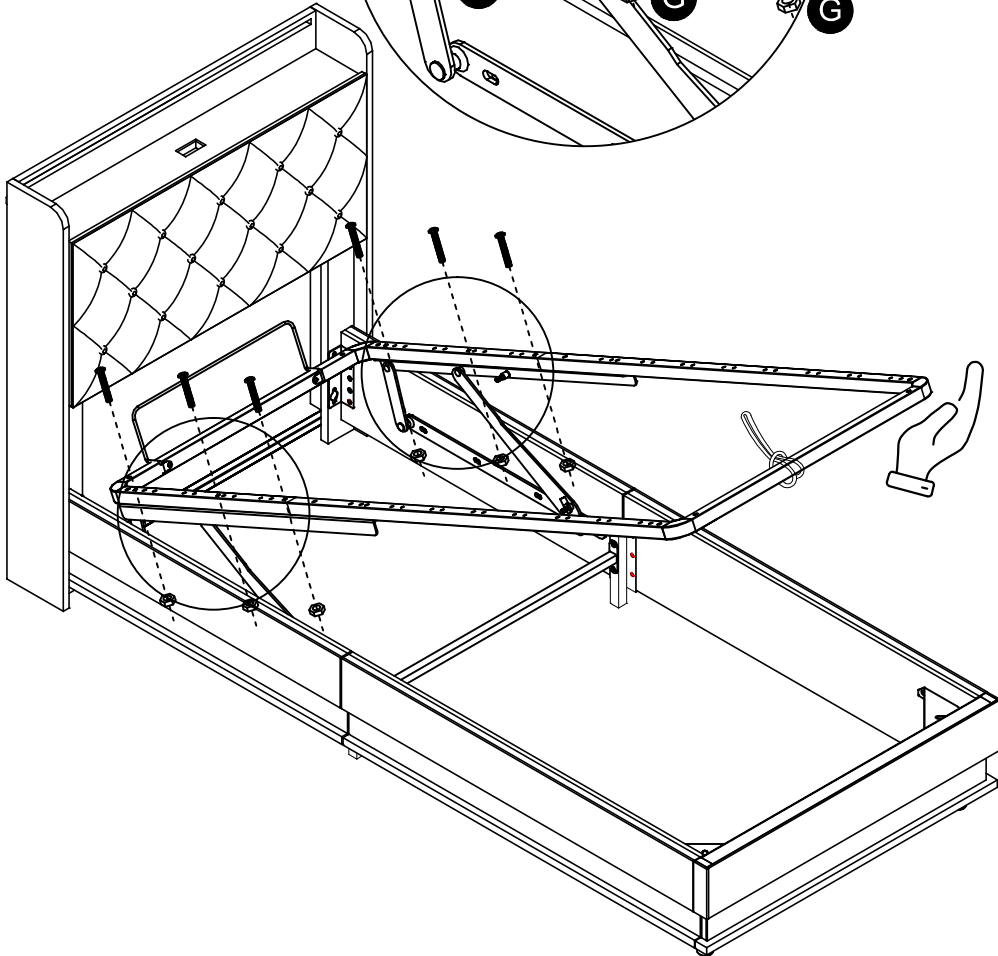
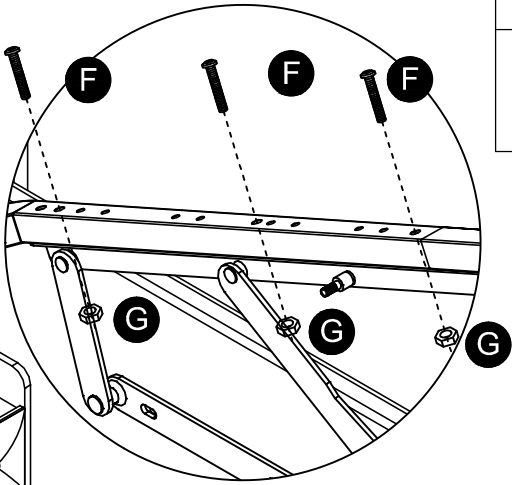

Step:26



M8
G 4PCS

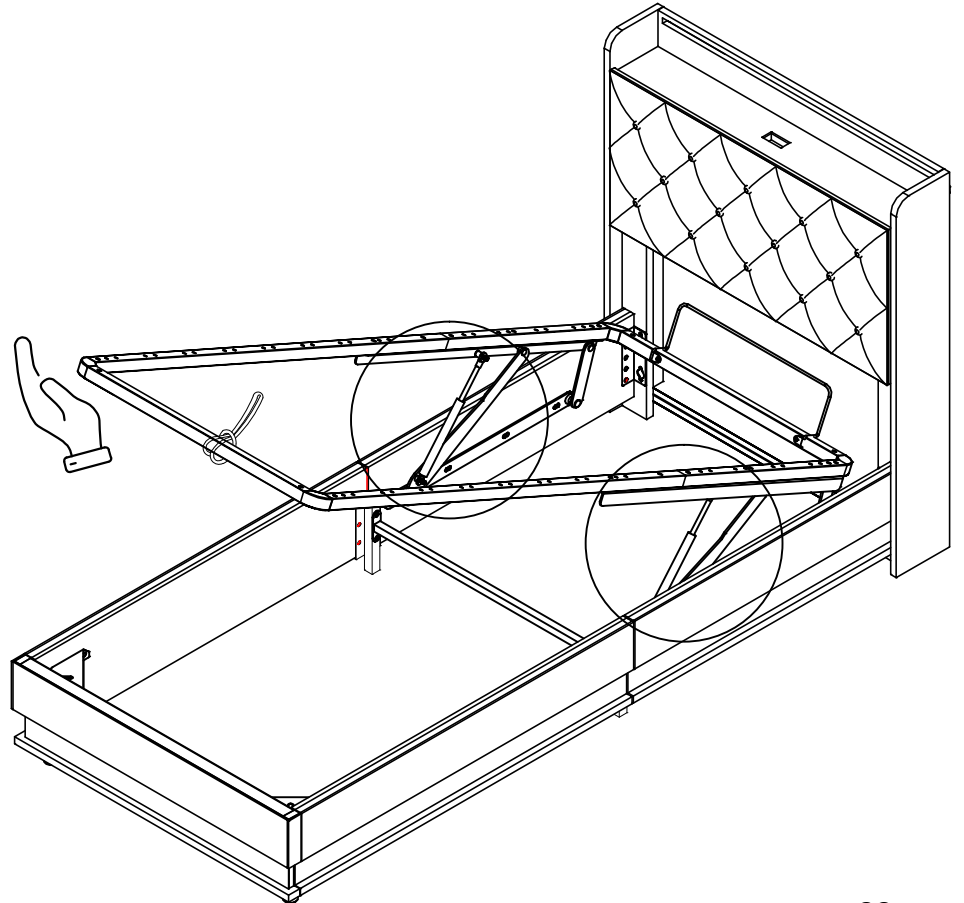
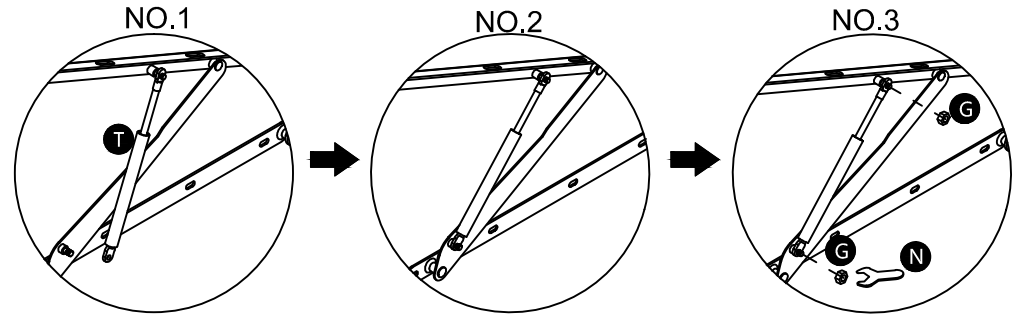

Step:27

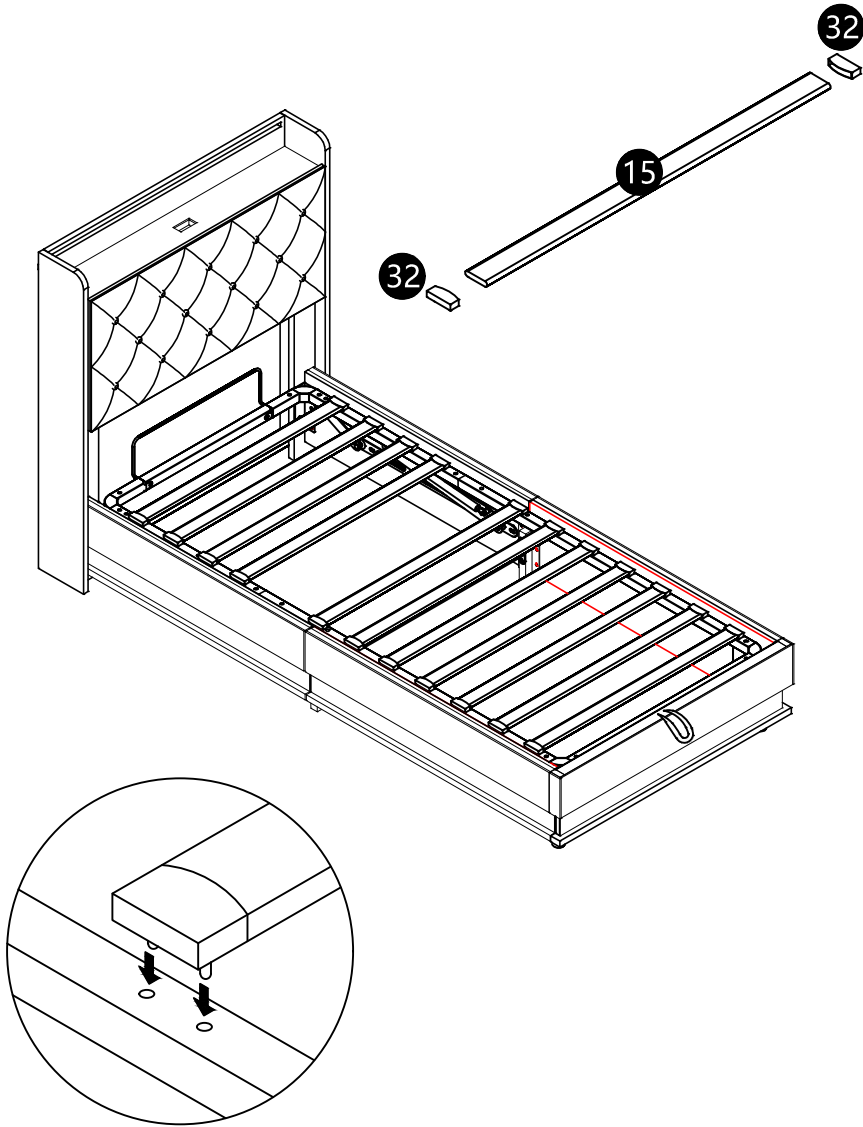

Step:28

M8*20
D 2PCS

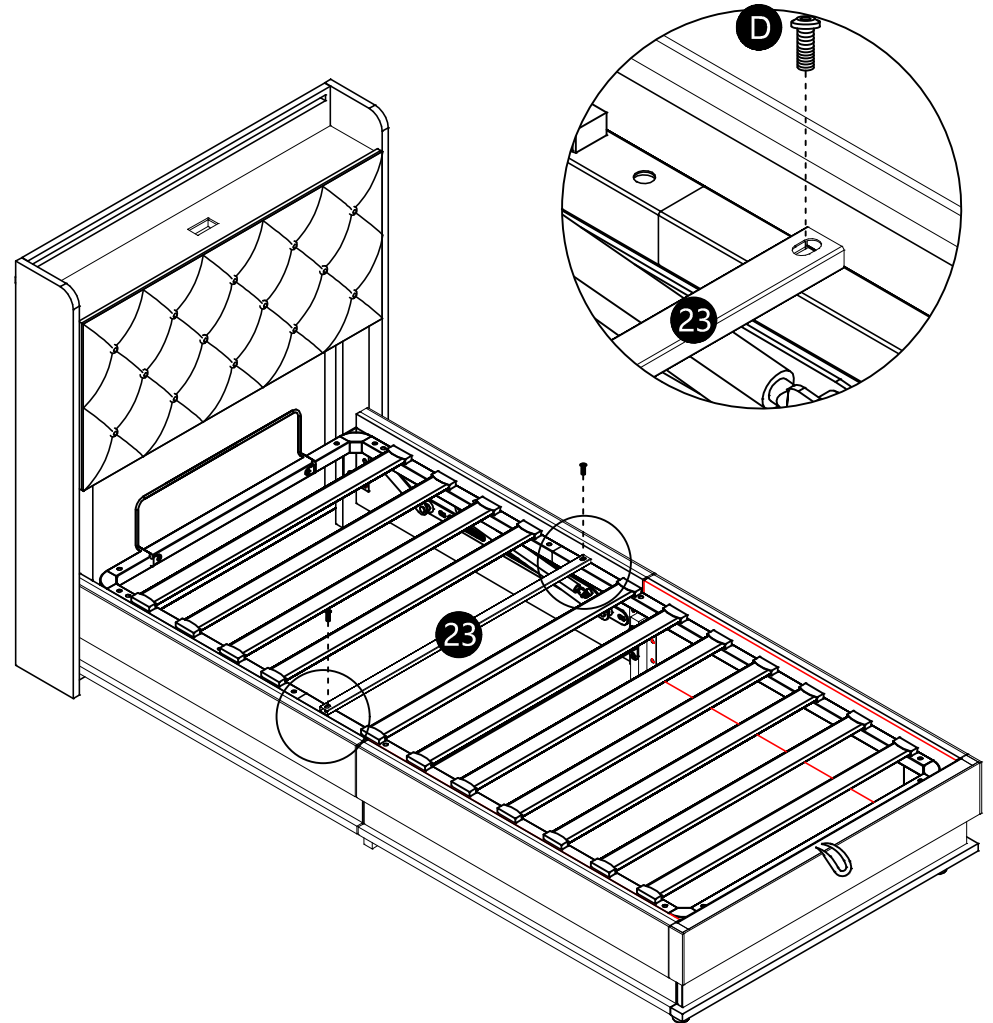

Step:29

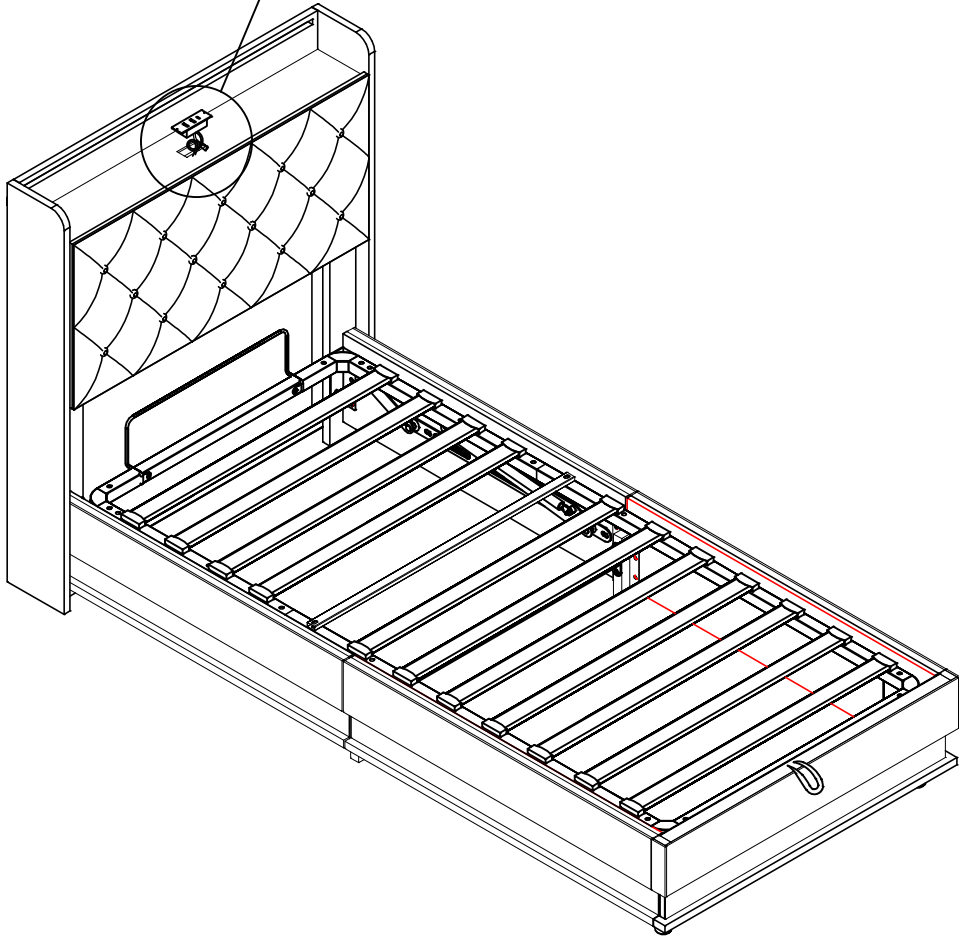
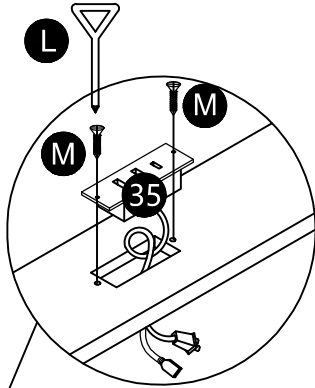

M3*12
M 2PCS



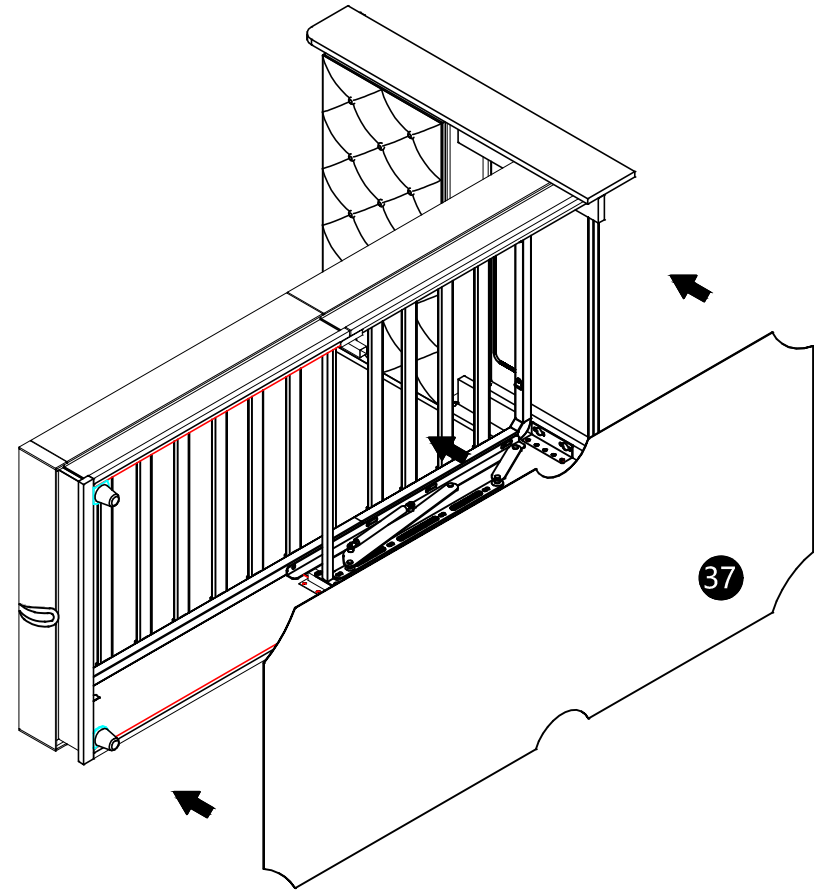

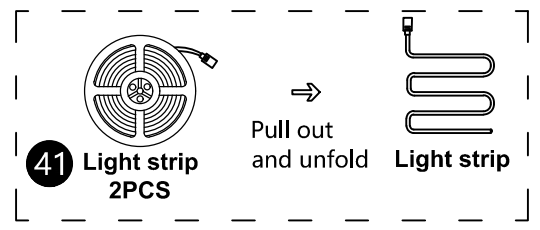
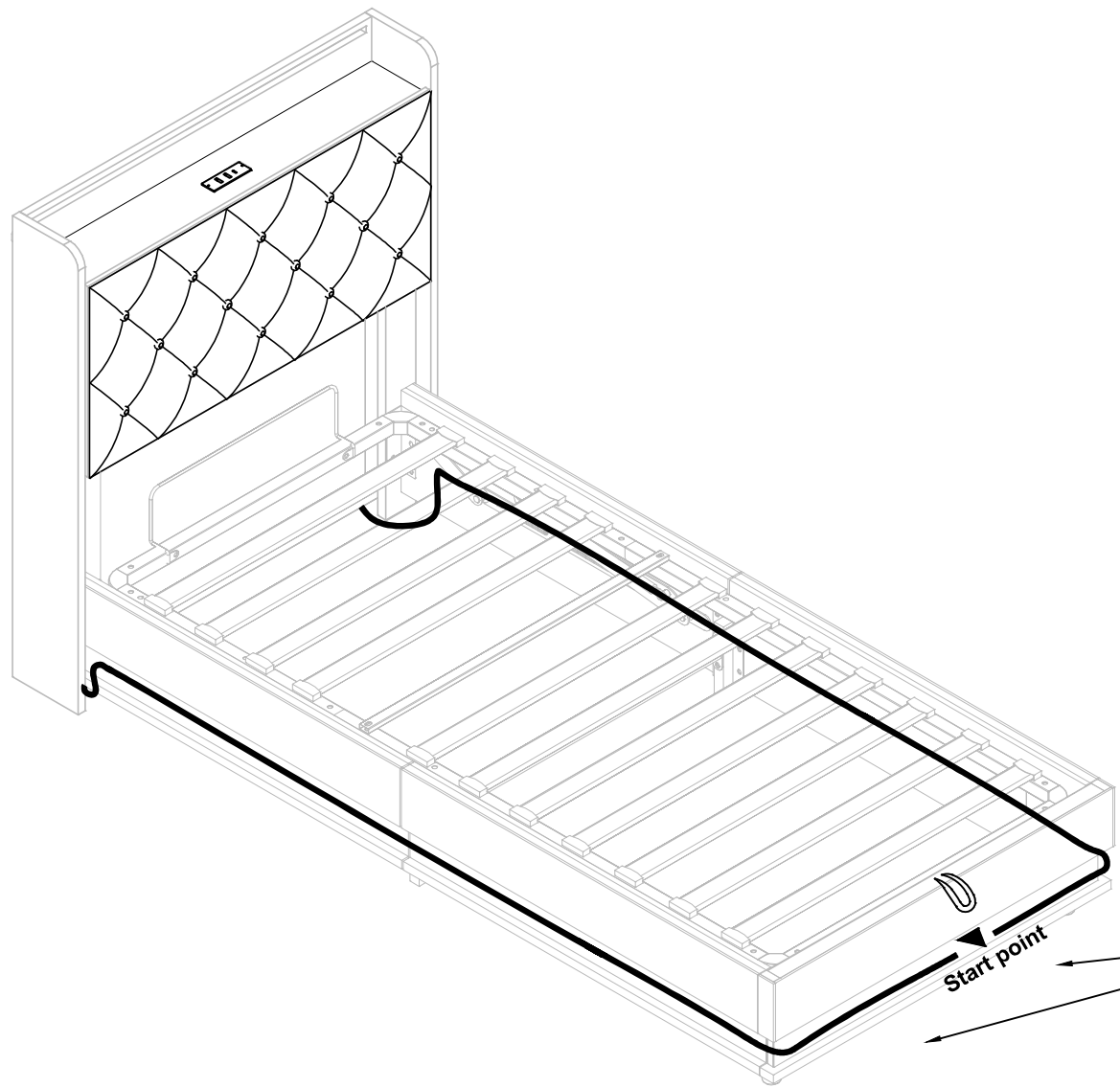
Step:30



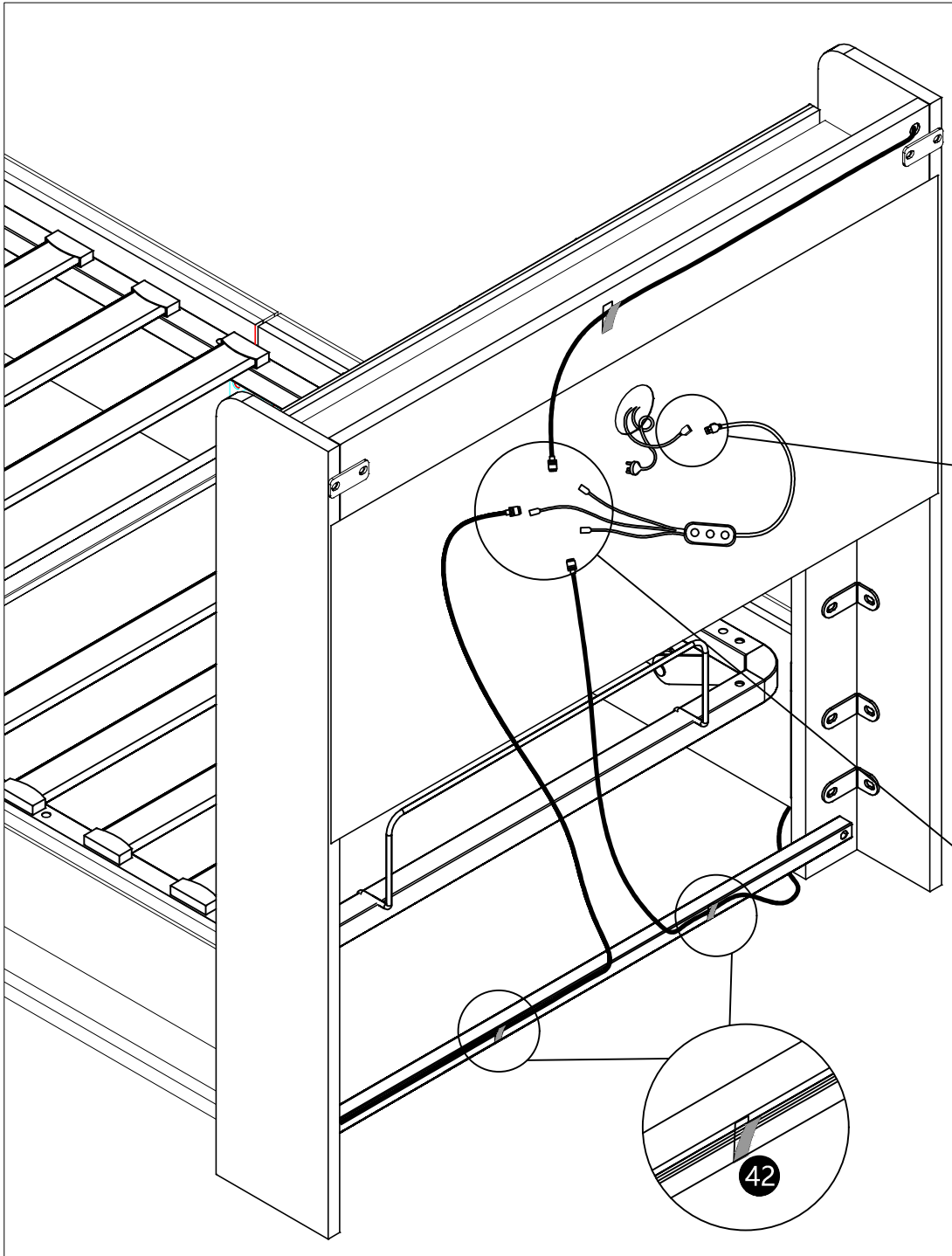

41  Stick the light strip on the inside of the groove

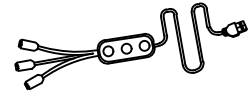

- 
 1PC
39 Power cord
- 
 3PCS
42 Strap magic tape

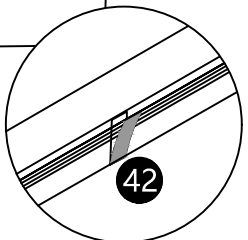
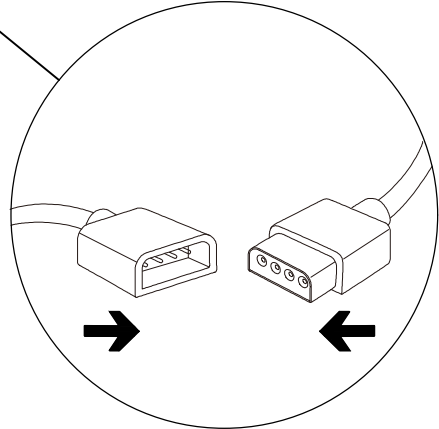
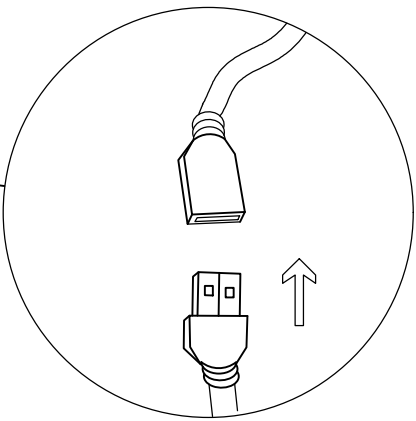

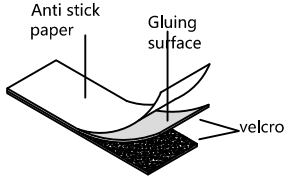

Strap magic tape

When the wires are disordered, tear off the anti stick paper, paste it on the place where the wires pass, and then bind the wires.

