

ASSEMBLY INSTRUCTIONS

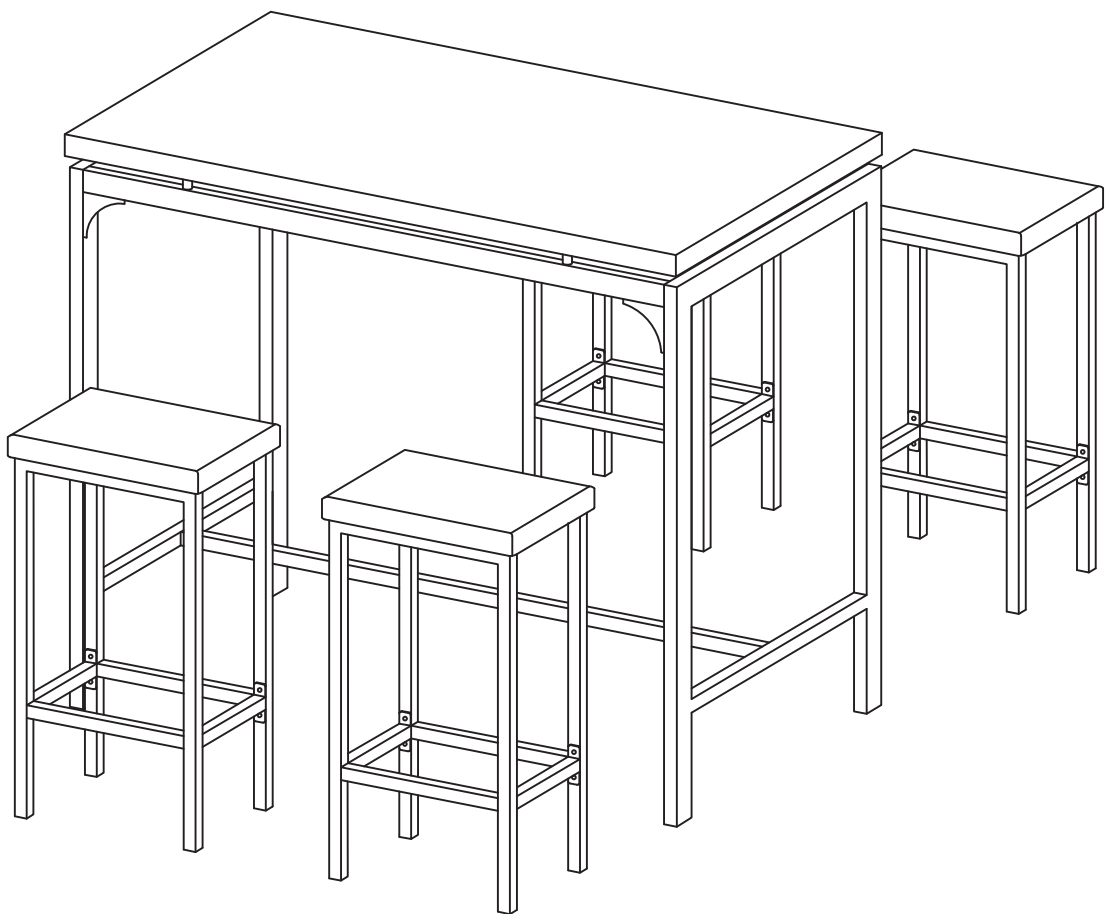

5pc Bar Set

ASSEMBLY INSTRUCTIONS

ASSEMBLY TIPS:

1. Remove hardware from box and sort by size.
2. Please check to see that all hardware and parts are present prior to start of assembly.
3. Please follow attached instructions in the same sequence as numbered to assure fast & easy assembly.



WARNING!



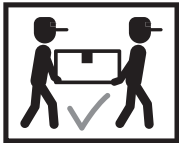



1. Don't attempt to repair or modify parts that are broken or defective. Please contact the store immediately.
2. This product is for home use only and not intended for commercial establishments.

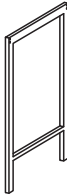

ASSEMBLY TIME

20 MINUTES

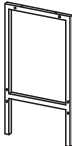







PARTS IDENTIFICATION

A	Table Top		1 PC
B	Table Side Frame		2 PCS
C	Table Top Crossbar		2 PCS
D	Table Bottom Crossbar		1 PC
E	Table Corner Support		4 PCS
F	Chair Seat		4 PCS
G	Chair Side Frame		8 PCS
H	Chair Top Crossbar		8 PCS
I	Chair Bottom Crossbar		8 PCS

NOTE:

QUANTITIES SHOWN ARE FOR ONE TABLE WITH FOUR CHAIRS

HARDWARE IDENTIFICATION

	DESCRIPTION	FIGURE	Q'TY
1	Bolt (M6x8MM)		16PCS
2	Bolt (M6x40MM)		8 PCS
3	Bolt (M6x50MM)		2 PCS
4	Bolt (M6x80MM)		4 PCS
5	Flat Gasket Ø16*Ø6.5*T2.0		4 PCS
6	Bolt (M6x12MM)		8X4 PCS
7	Bolt (M6x35MM)		4X4 PCS
8	Bolt (M6x45MM)		4X4PCS
9	Allen Wrench (M4)		1PC

NOTE:
QUANTITIES SHOWN ARE FOR ONE TABLE WITH FOUR CHAIRS

ASSEMBLY INSTRUCTIONS

STEP 1

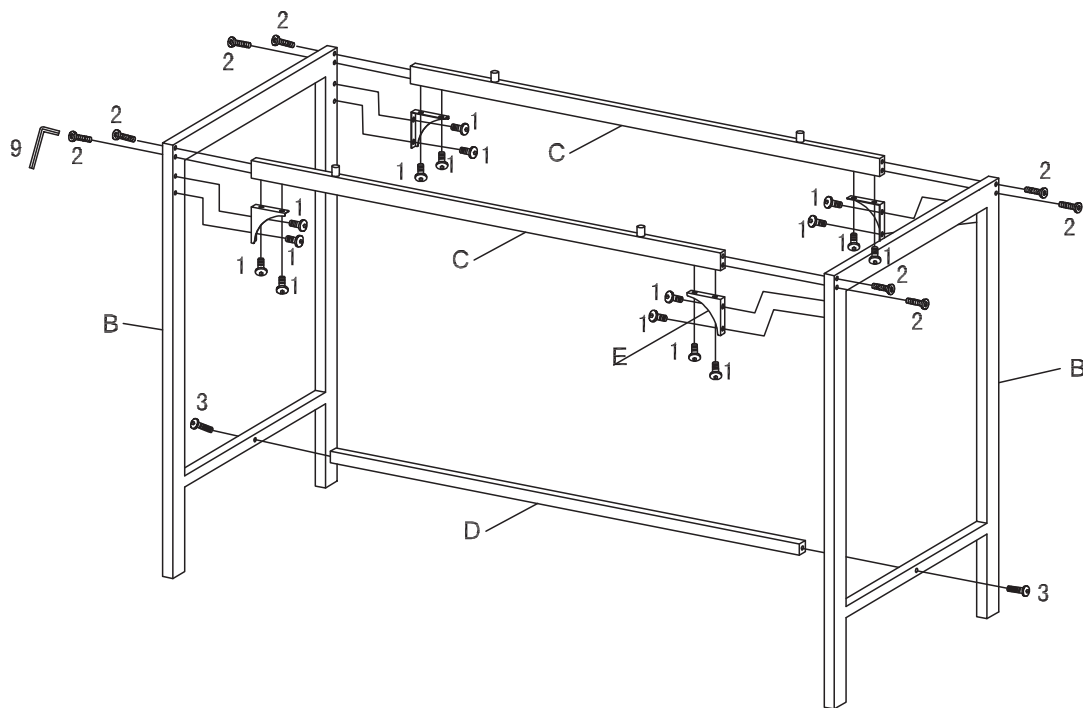

STEP 2

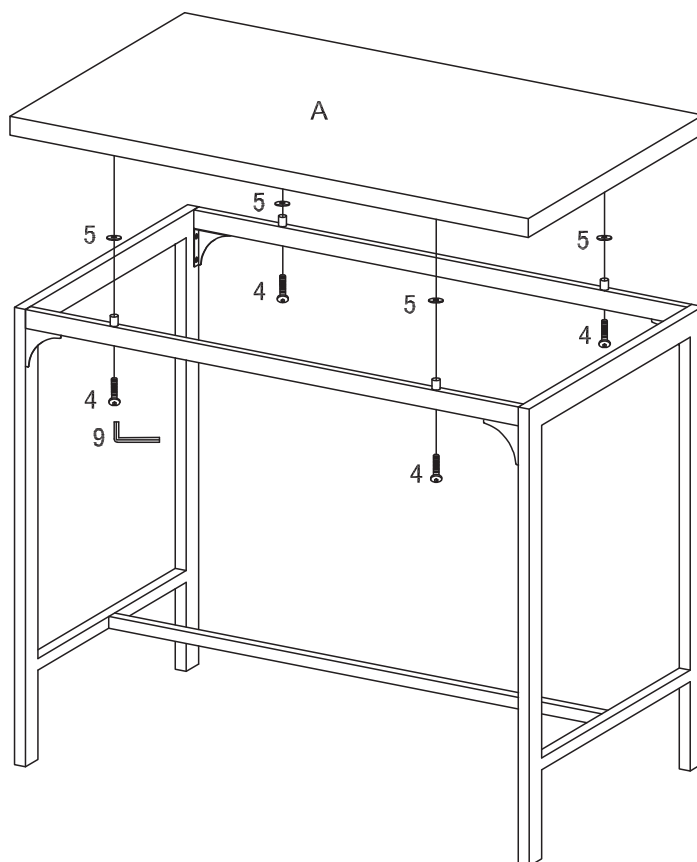

ASSEMBLY INSTRUCTIONS

STEP 1

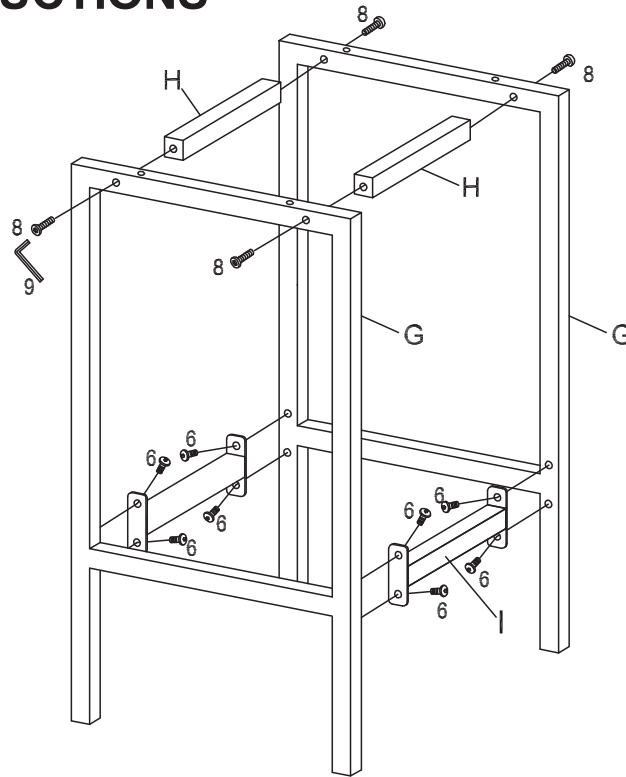

STEP 2

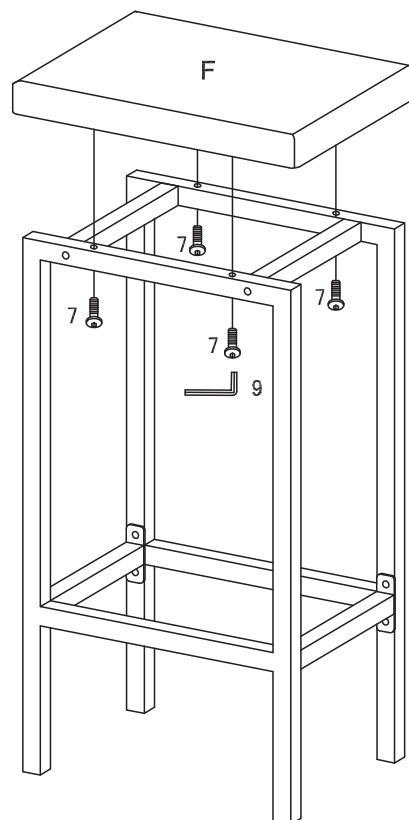

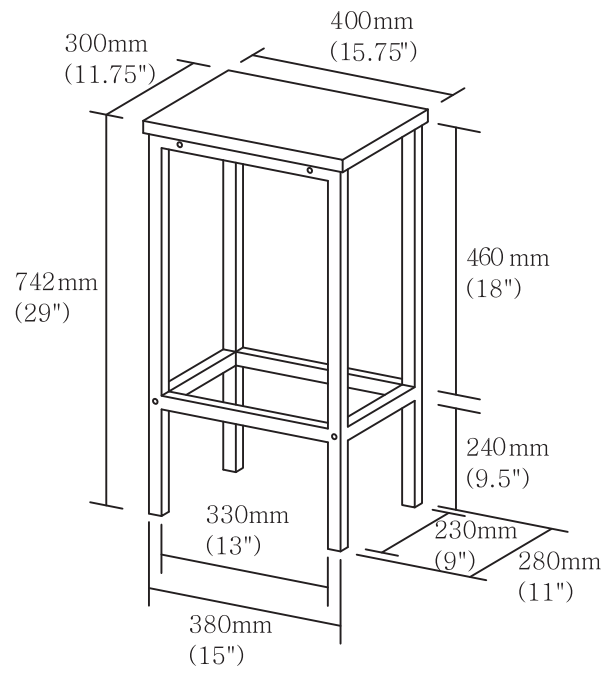
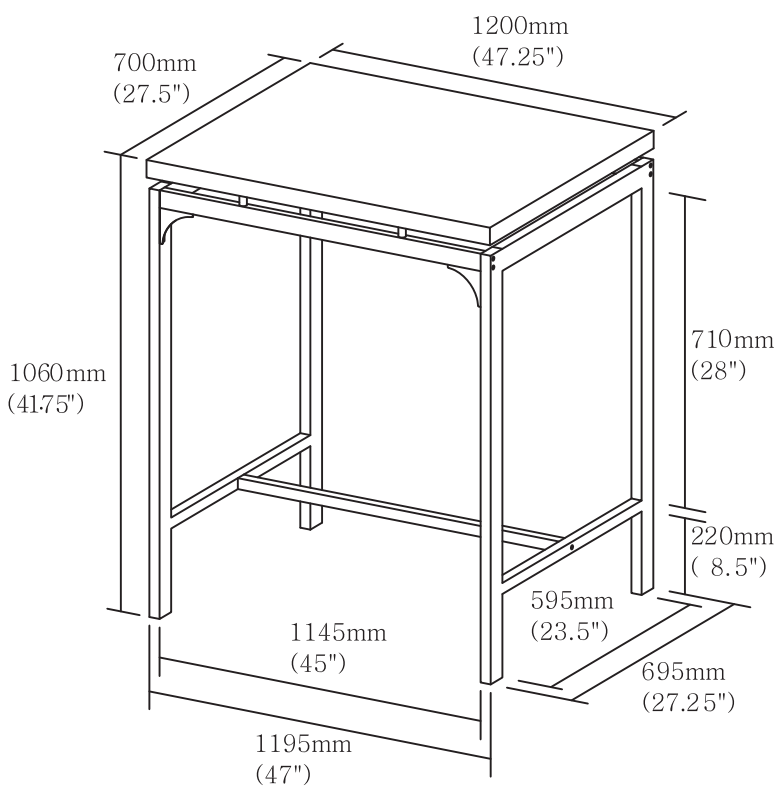

Note: Dimension tolerance $\pm 5\%$