

# 3 Pieces Patio Furniture Set

---

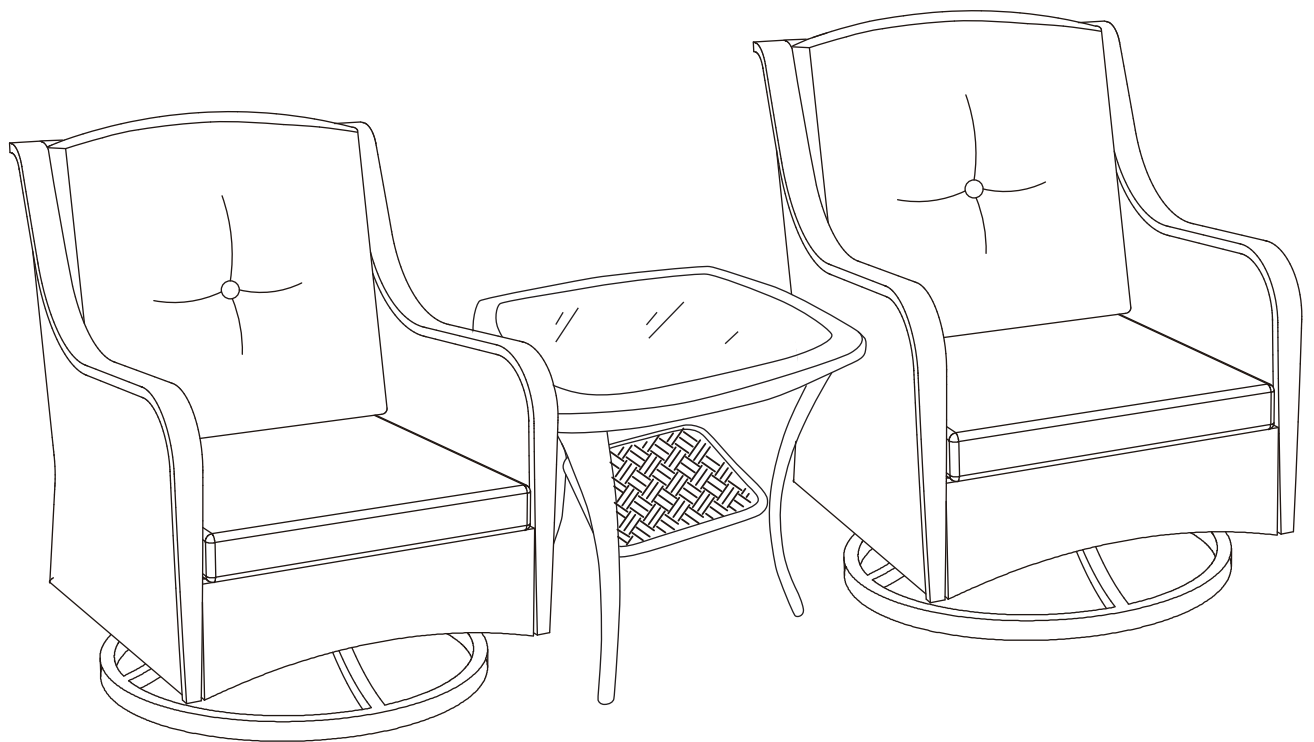

## NOTICE

### PLEASE RETAIN THESE INSTRUCTIONS FOR FUTURE REFERENCE.

**Dear Customer,**

**Thank you for shopping with us!**

When you receive the product, please make sure that all the parts are included. Then please browse the entire installation manual before assembling.

If any problem occurs unsatisfactorily as follows:

- A. The outer box is damaged
- B. The product is damaged / bent / cracked while you open the box
- C. The parts / accessories / assembly tools are missing
- D. The product is hard to assemble
- E. The instructions are not clear and can not be referred
- F. The product has functional problems
- G. Other aspects that you are not satisfied with

Please contact us if you have any questions.

Our team will reply within 24 hours and will do our best to resolve your problem for you.

### SAFTY NOTES

- Handle components with care due to sharp corners.
- The installation of this product may require the use of electric drills, please pay attention to safety.

### CARE INSTRUCTIONS

- Wear gloves during assembly.
- Please note that this product is an assembled furniture. Do not tighten the screws at the first time during the installation process. After aligning all the screw holes, tighten them again.

# HARDWARE

1

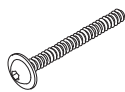

**M6\*40**  
16 PC

2



**M6\*35**  
32 PC

3



**M6\*15**  
12 PC

4



64 PC

5



32 PC

6

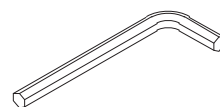

1 PC

7



1 PC

8

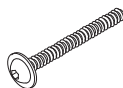

**M6\*45**  
8 PC

**PARTS**

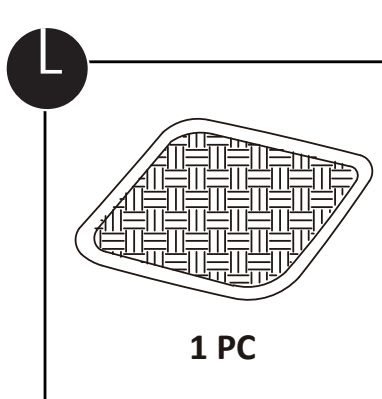
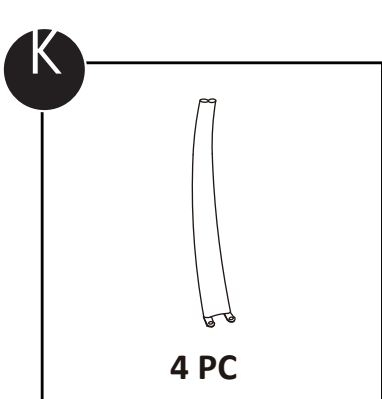
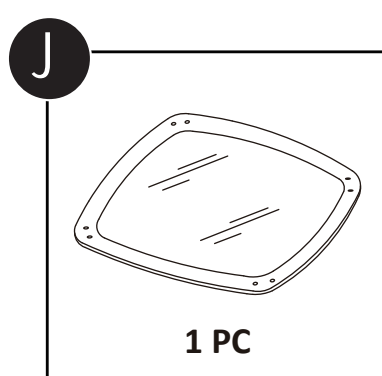
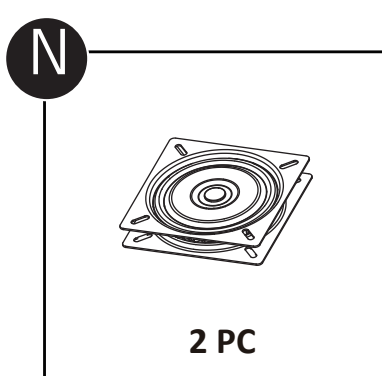
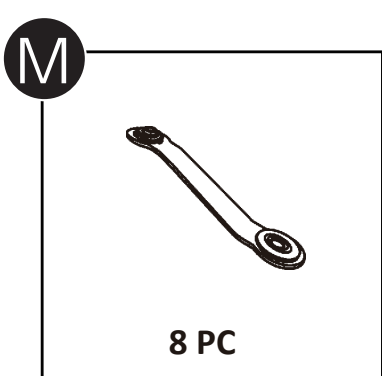
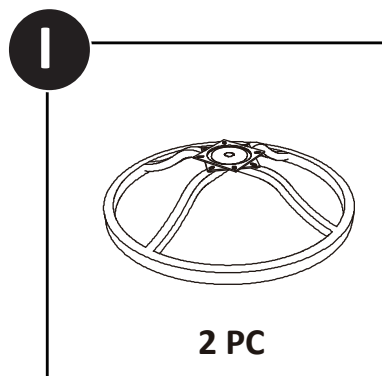
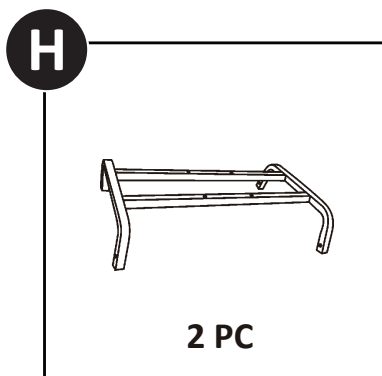
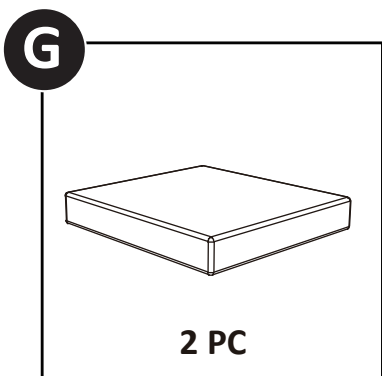
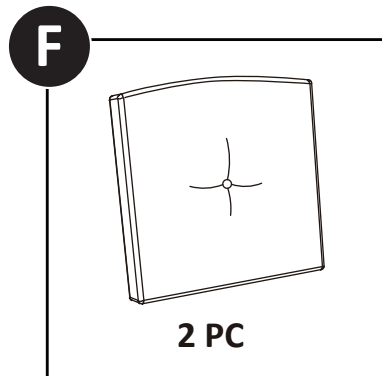
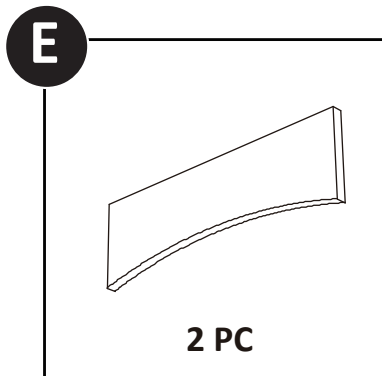
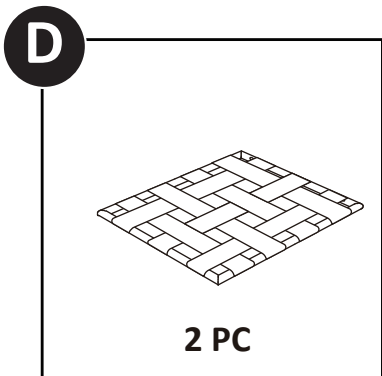
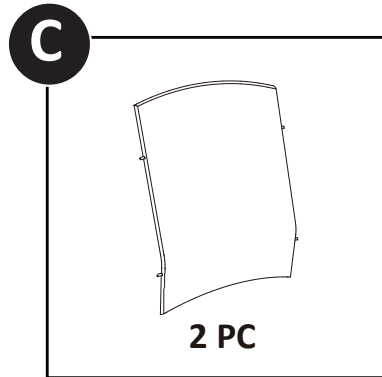
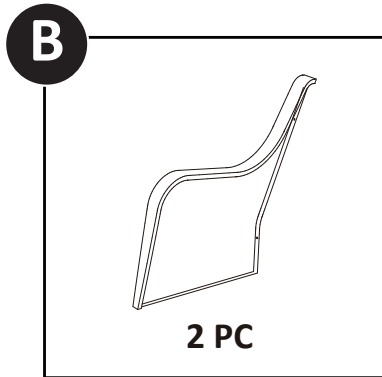
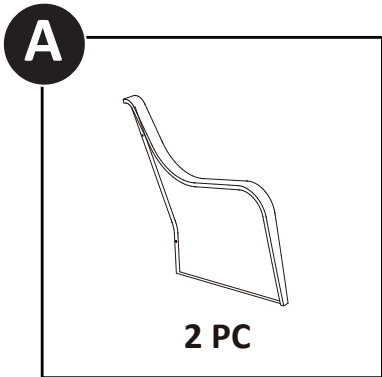

# PRODUCT ASSEMBLY

## Step 1

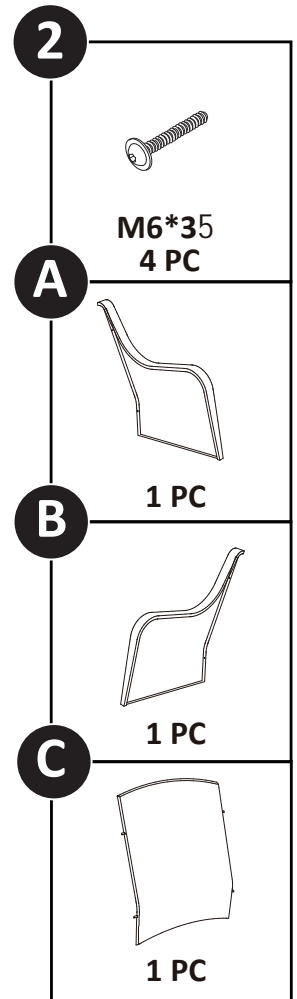
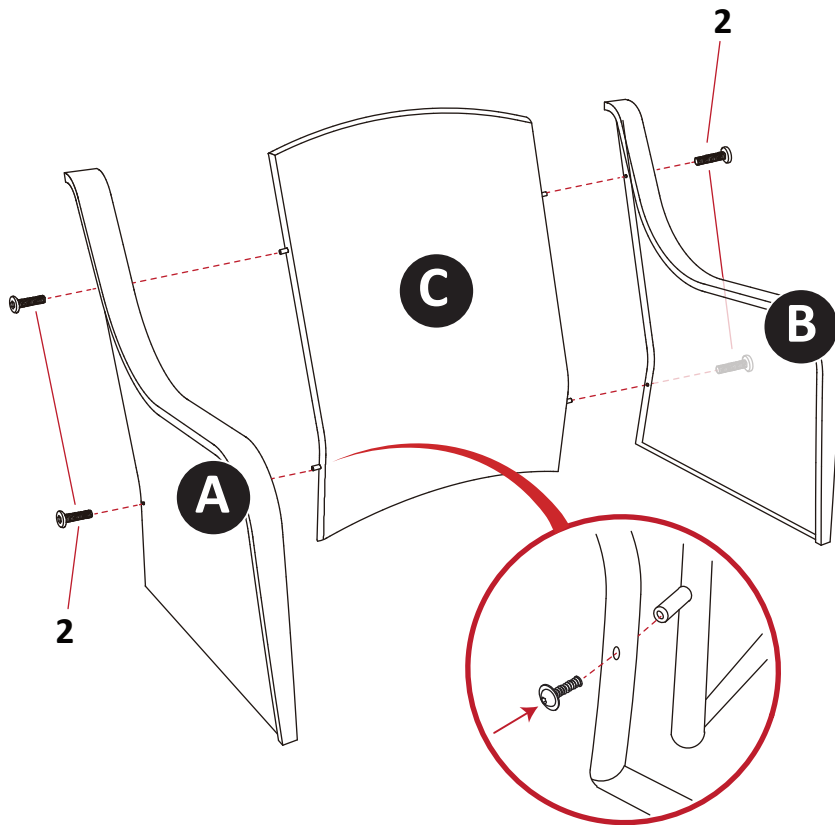

## Step 2

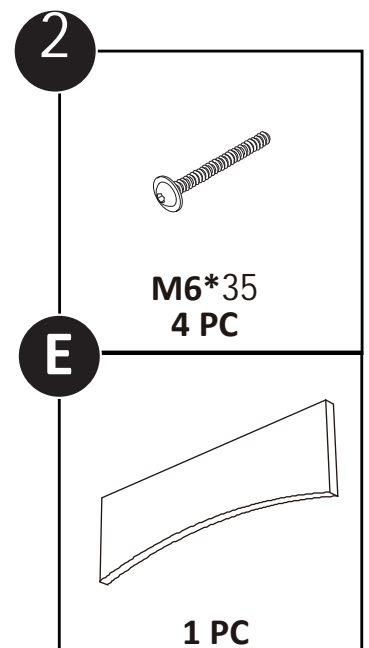
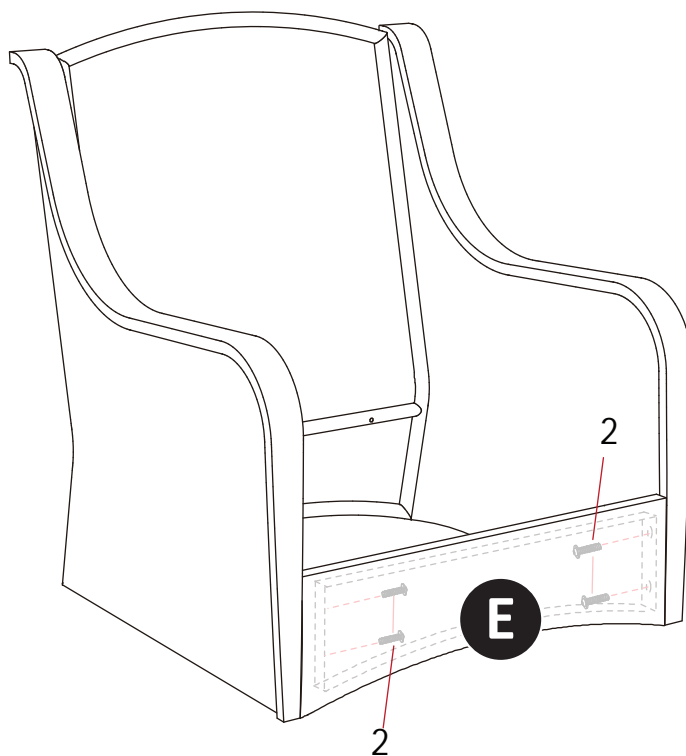

# PRODUCT ASSEMBLY

## Step 3

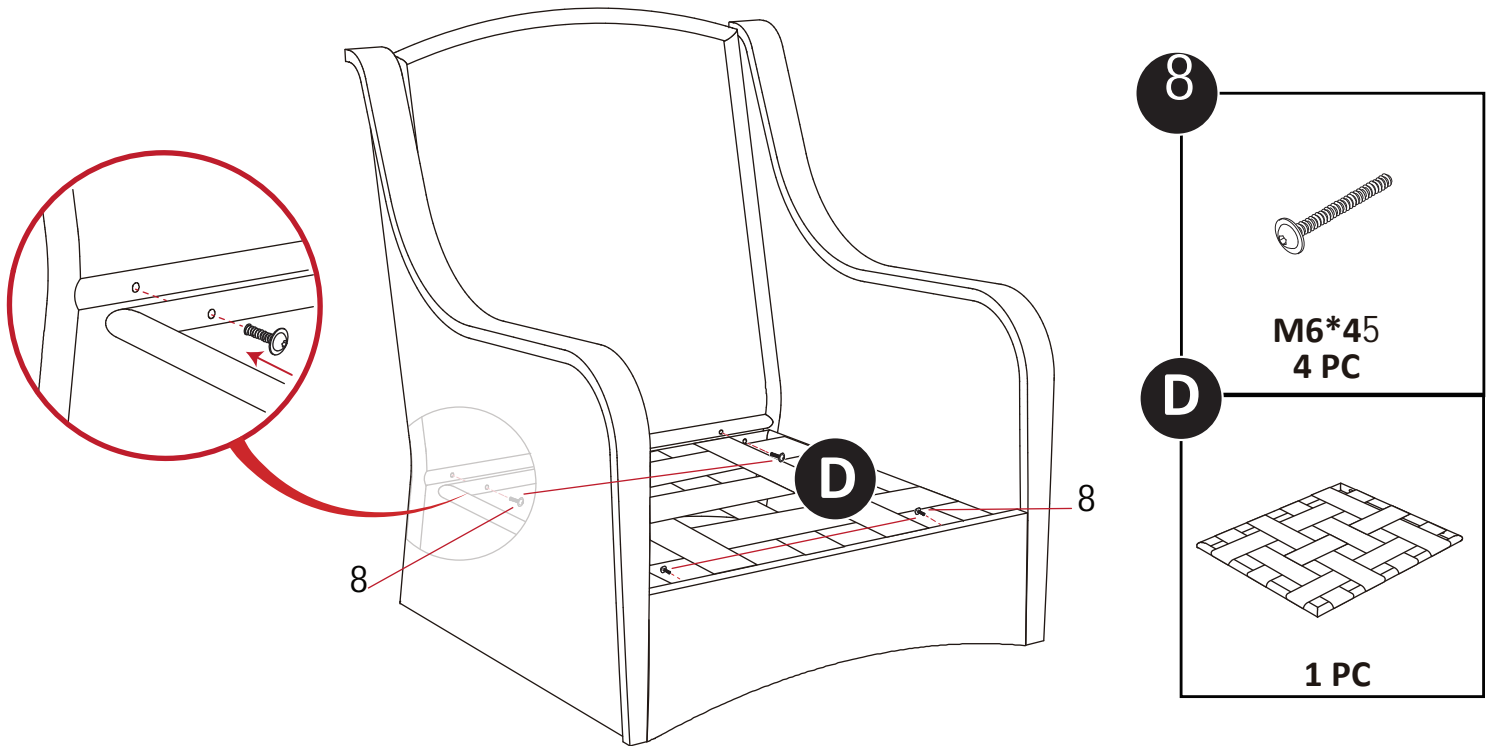

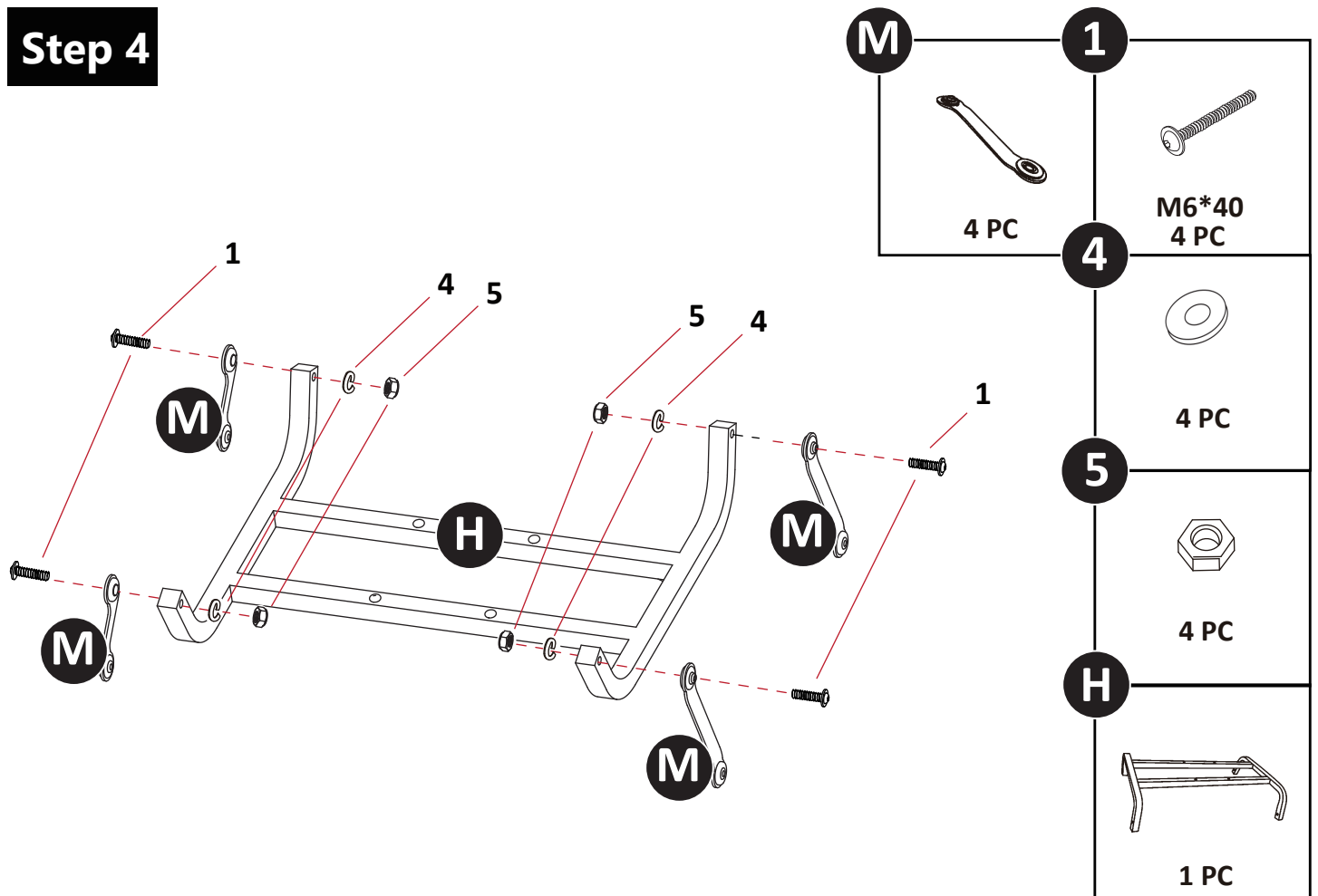

## Step 4



# PRODUCT ASSEMBLY

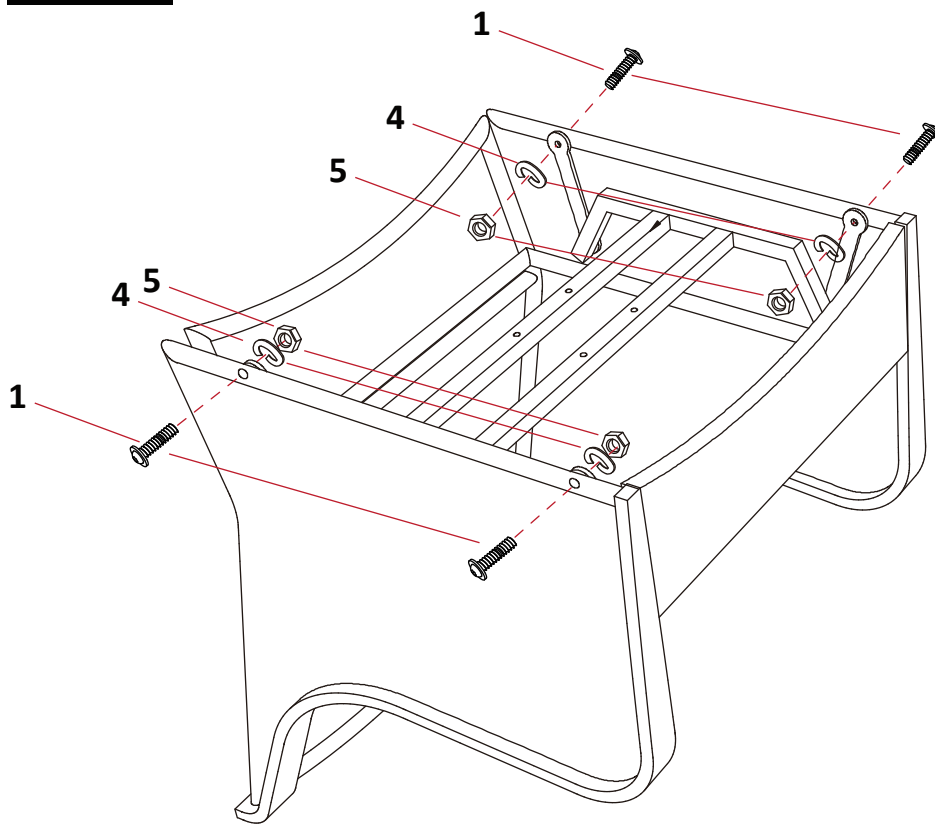

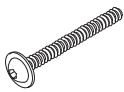
## Step 5

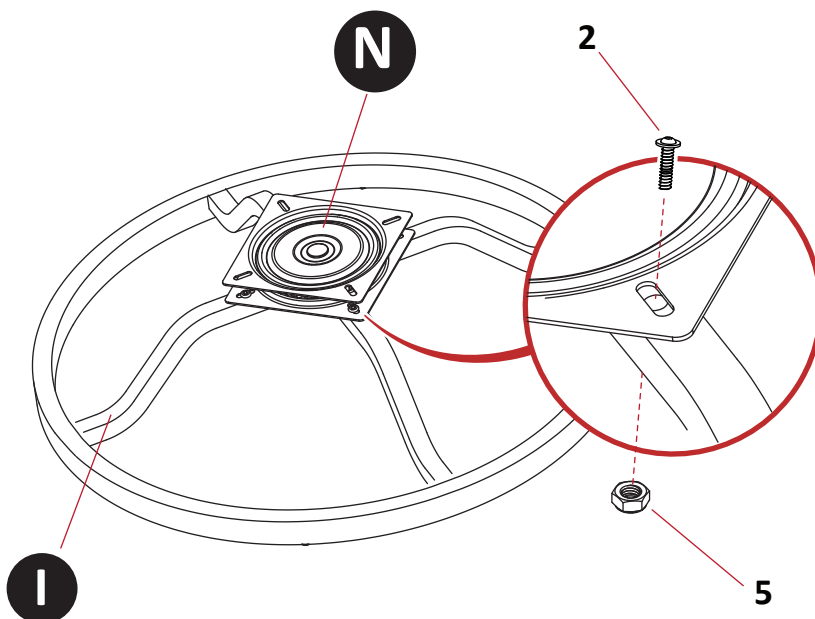

<b>1</b>	
	M6*40 4 PC
<b>4</b>	
	4 PC
<b>5</b>	
	4 PC

## Step 6

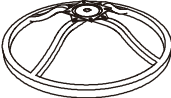

<b>2</b>	
	M6*35 4 PC
<b>5</b>	
	4 PC
<b>N</b>	
	1 PC
<b>I</b>	
	1 PC

# PRODUCT ASSEMBLY

## Step 7

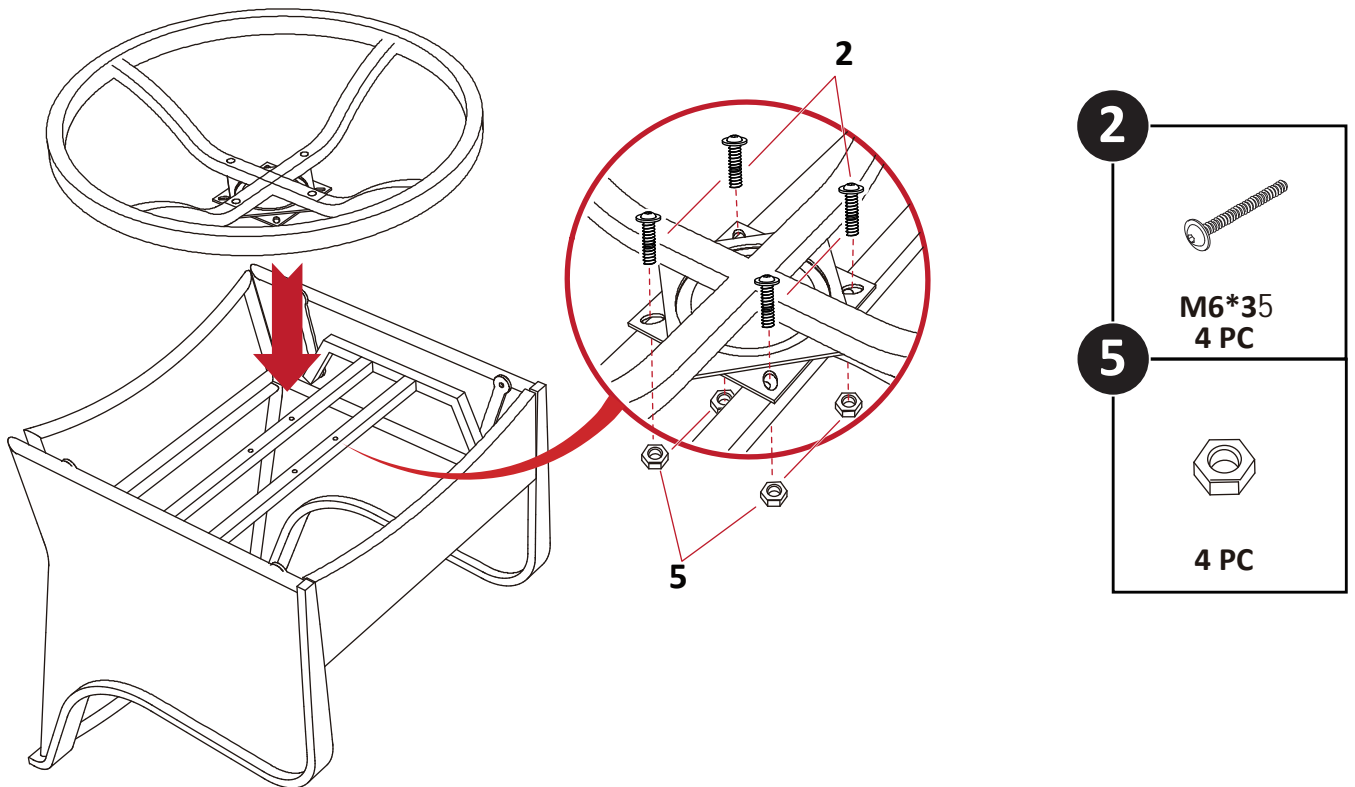

## Step 8

Put on the seat cushion and back cushion

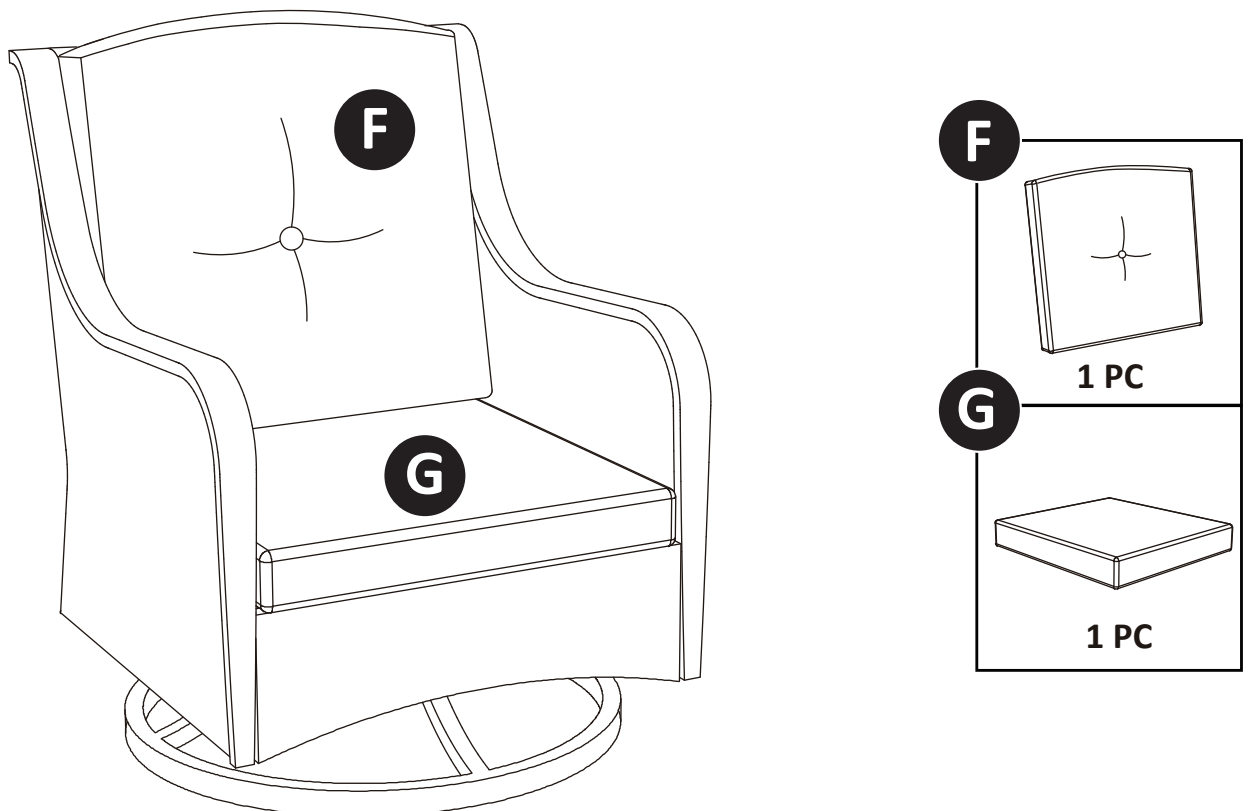

# PRODUCT ASSEMBLY

## Step 9

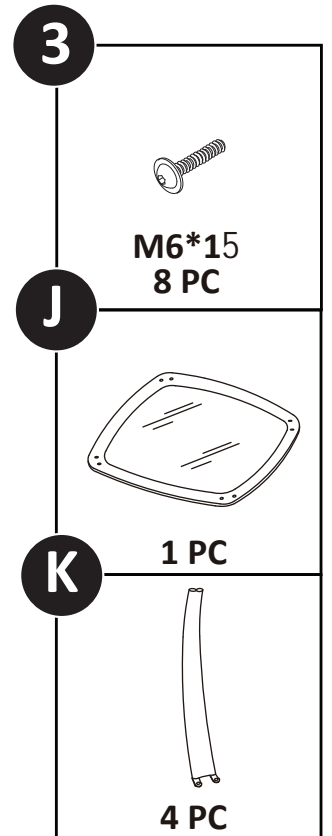
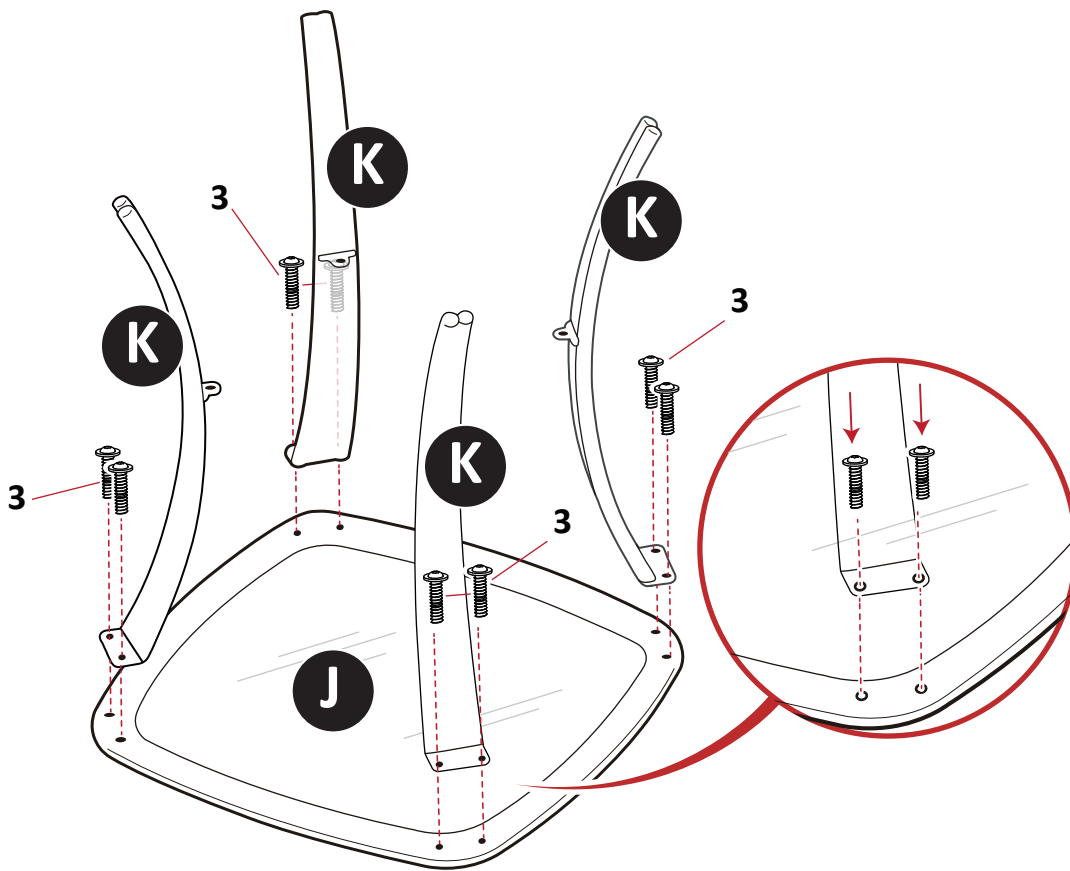

## Step 10

