

Read this instruction carefully. See hardware and furniture part list for guidance. Be sure all parts are complete, before you assemble. Place all wooden furniture parts on a clean and flat soft surface to prevent from being scratched. Follow the figure to start assembling.

CAUTIONS : 1. Do not FULLY - TIGHTEN the nut or nut bolt until all nut or bolt is ready assembled.
2. Do not OVER - TIGHTEN the nut or bolt to avoid causing damages to the thread.
3. Keep all hardware parts out of reach of children.

NOTE : THE LIST AND QUANTITY SHOWN ARE FOR 1 UNIT ASSEMBLY.
Tool needed : Screwdriver & Rubber Mallet (not provided).

PART LIST		
ITEM	DESCRIPTION	QTY
A	HEADBOARD	1 PC
B	FOOTBOARD	1 PC
C	HEADBOARD LEG SUPPORT WOOD	2 PCS
D	FOOTBOARD LEG SUPPORT WOOD	1 PC
E	BED LEG	4 PCS
F	SIDE RAIL	2 PCS
G	HEADBOARD WING	2 PCS
H	CENTER RAIL	2 PCS
I	CENTER SUPPORT LEG	6 PCS
J	CENTER SUPPORT WOOD	3 PCS
K	BED SLAT	39 PCS

HARDWARE LIST		
ITEM	DESCRIPTION	QTY
1	JCBC BOLT M6 x 40mm	4 PCS
2	JCBC BOLT M6 x 45mm	4 PCS
3	JCBB BOLT M8 x 40mm	7 PCS
4	M6 FLAT WASHER	4 PCS
5	M8 SPRING WASHER	7 PCS
6	M8 FLAT WASHER	7 PCS
7	WOOD DOWEL M8 x 30mm	4 PCS
8	BED SLAT SIDE FITTER	26 PCS
9	BED SLAT CENTER FITTER	26 PCS
10	WOOD SCREW M3.5 x 16mm	12 PCS
11	WOOD SCREW M4 x 20mm	4 PCS
12	M4 ALLEN KEY (BALL SHAPE)	1 PC
13	M5 ALLEN KEY (BALL SHAPE)	1 PC

STEP 1

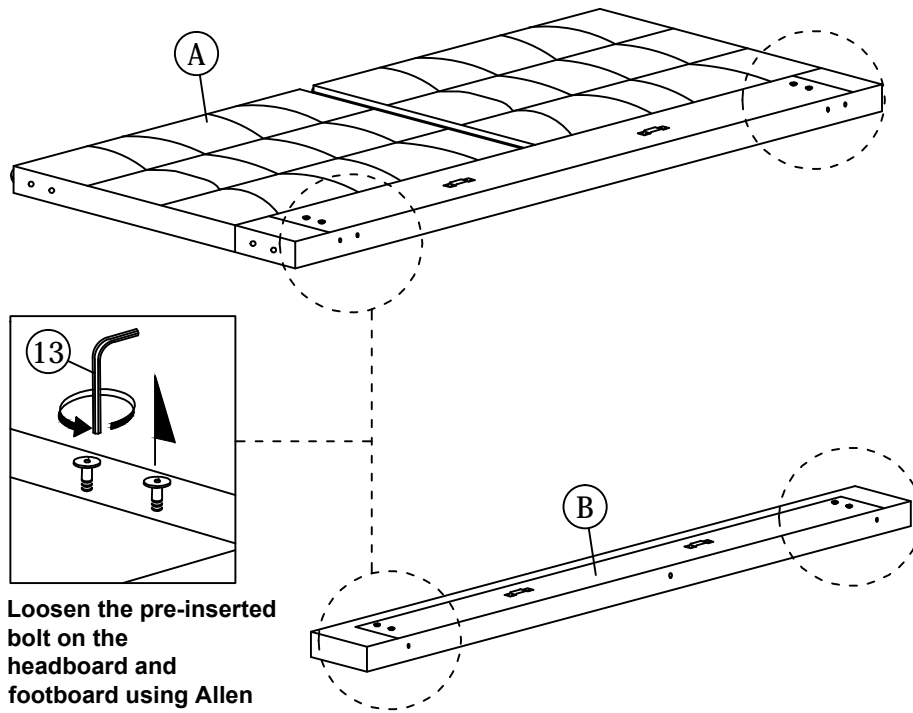

Loosen the pre-inserted bolt on the headboard and footboard using Allen key ball shape (13)

STEP 2

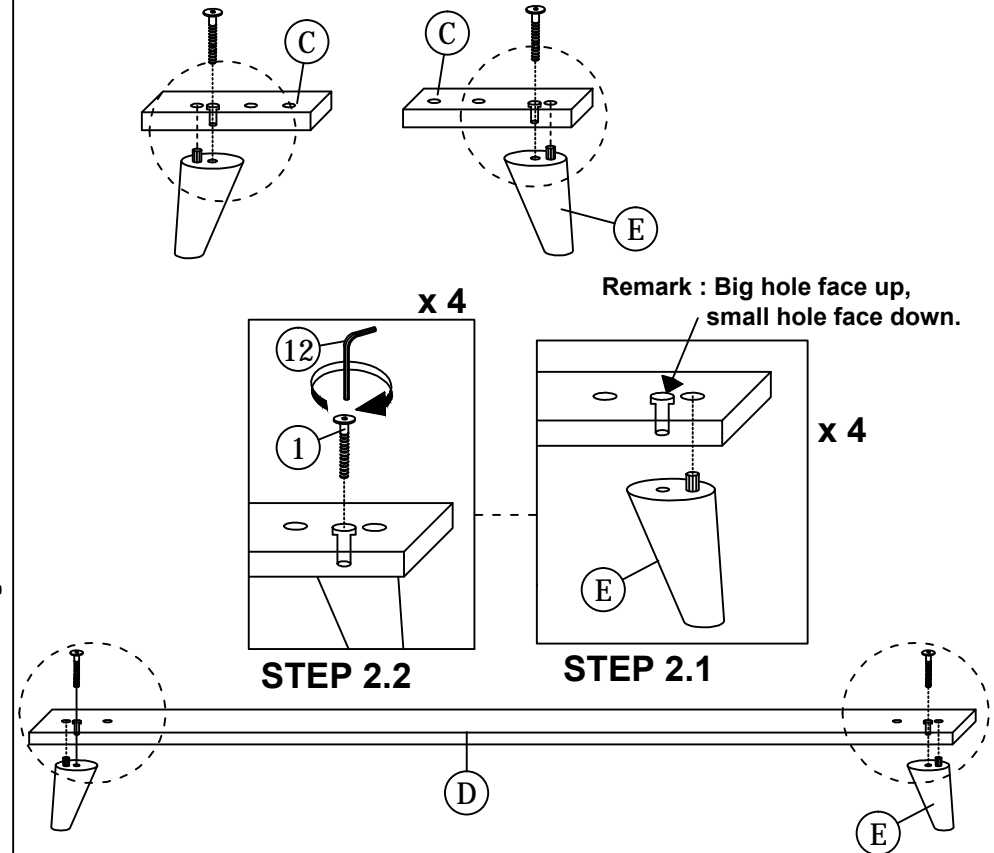

STEP 2.2

STEP 2.1

ASSEMBLY INSTRUCTIONS

STEP 3

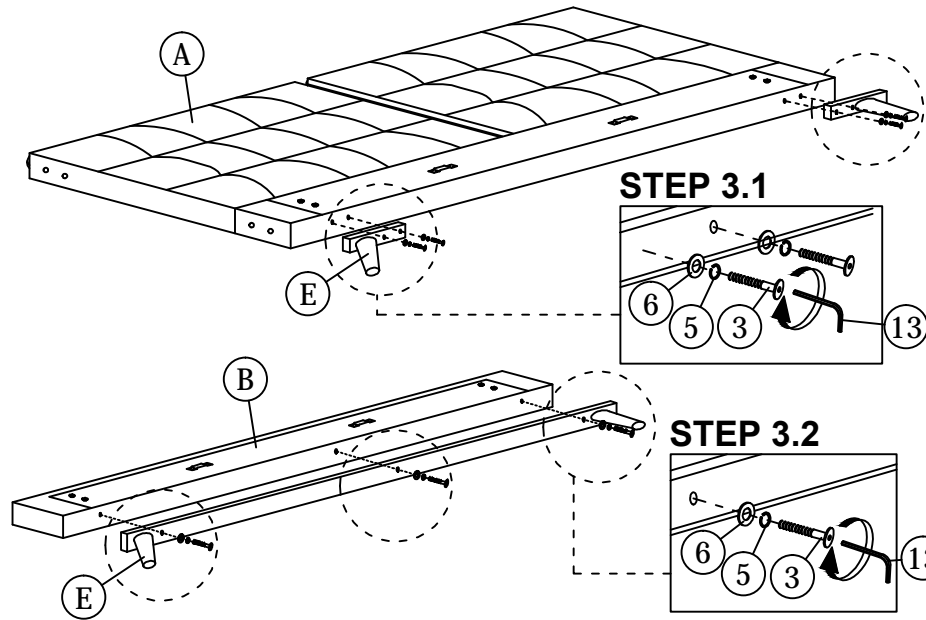

STEP 4

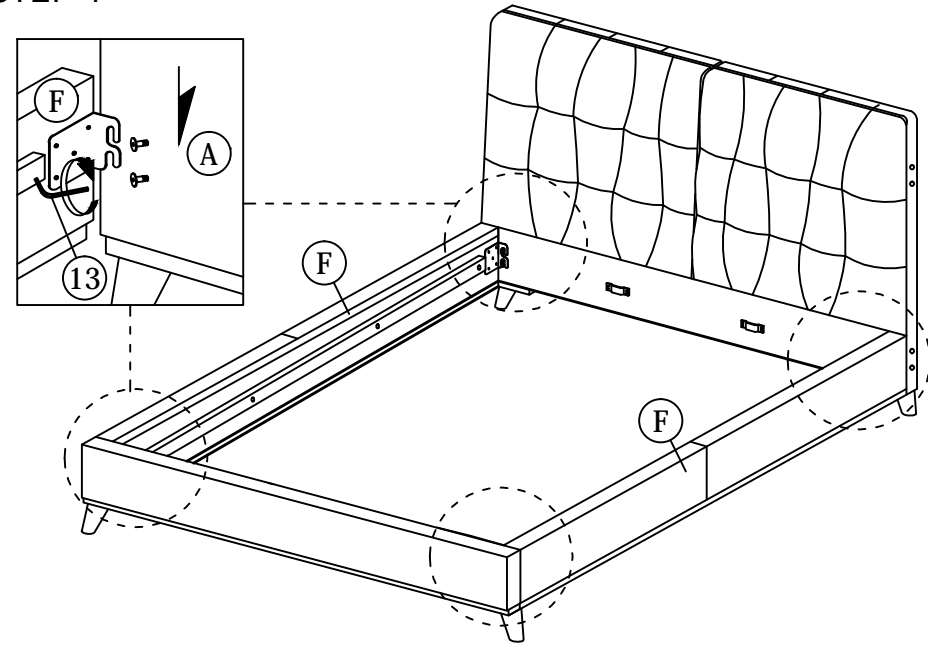

STEP 5

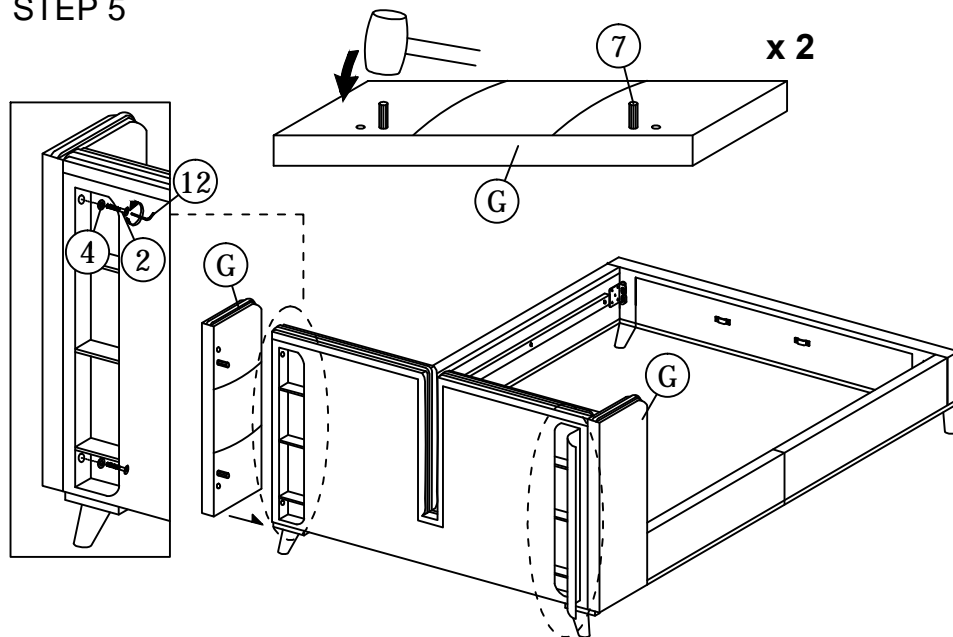

STEP 6

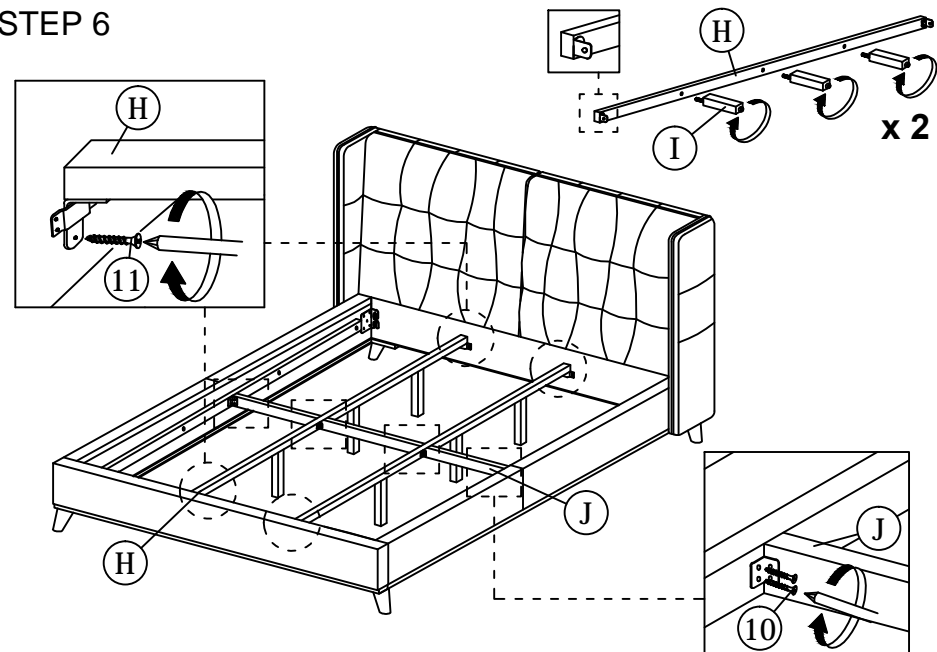

ASSEMBLY INSTRUCTIONS

STEP 7

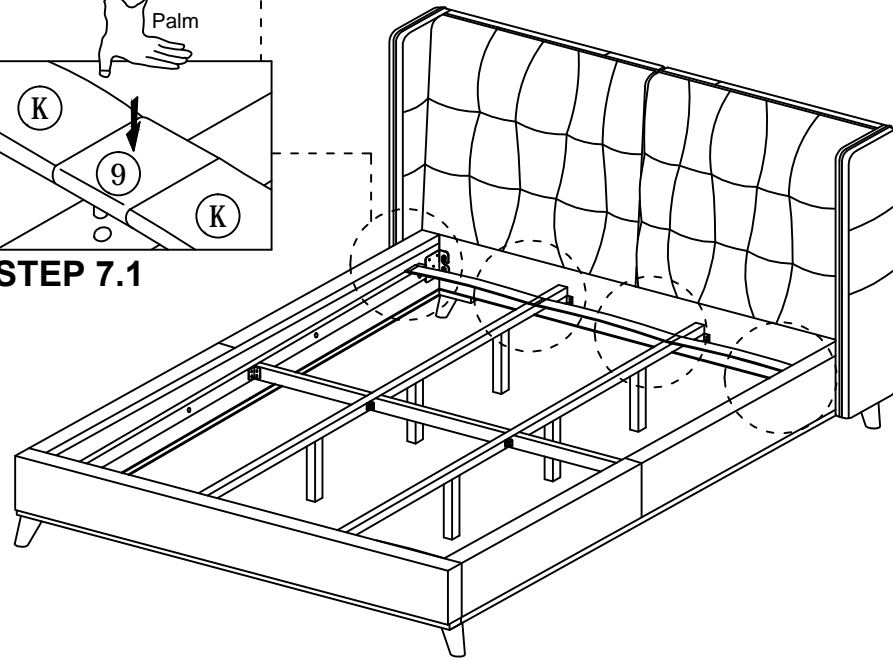
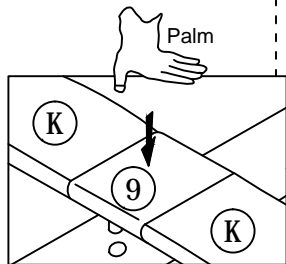
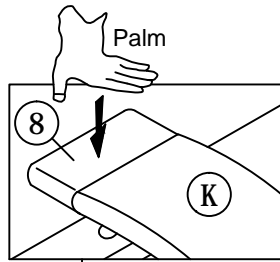
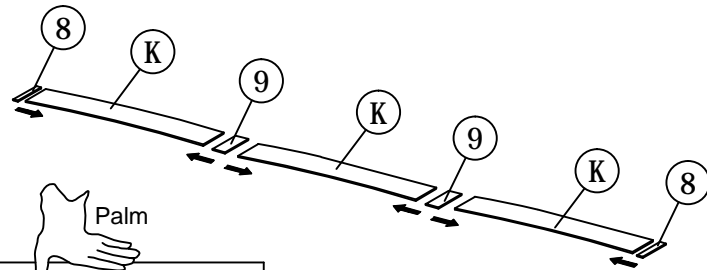

STEP 8

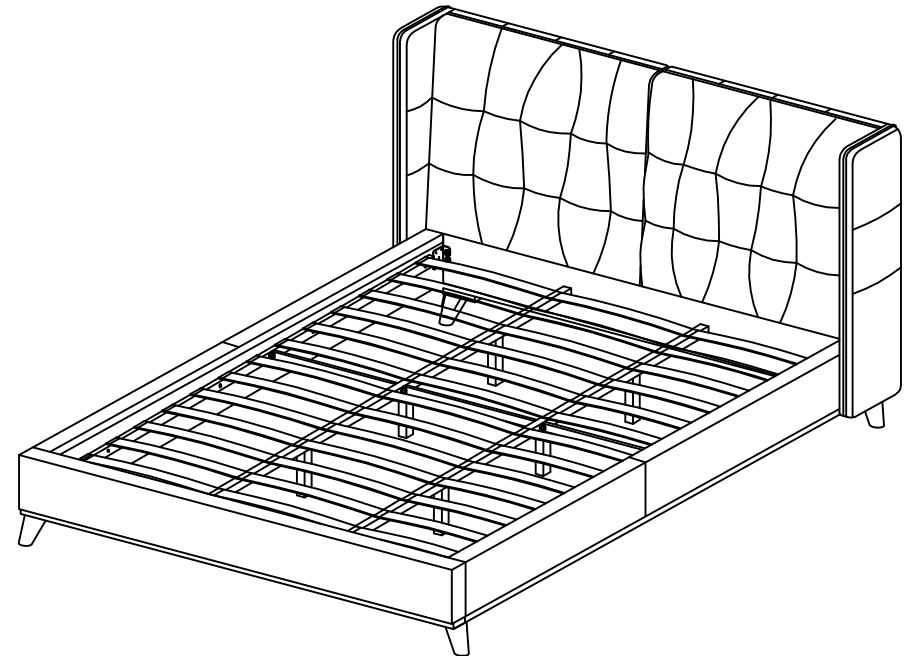

*** When moving the bed position, the center support legs must be adjust to be straight to avoid any broken problem.**