

# ORIGINAL INSTRUCTION MANUAL

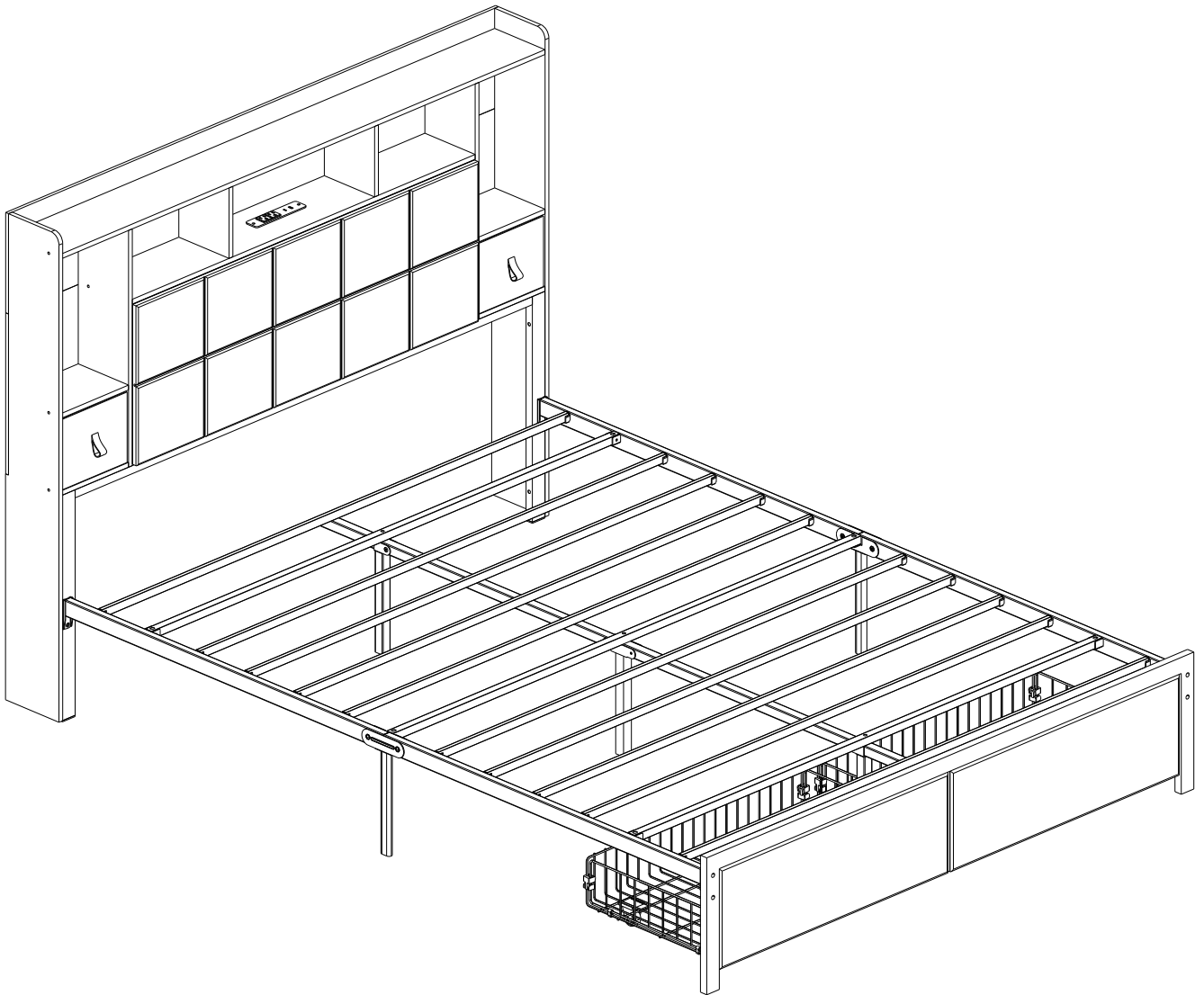

## Important Note

### HARDWARE NOTE :

1. Two or more people are required for assembly
2. Do not screw on the bolts too tight unless the installation is done. Make sure all bolts are tightly screwed before you use it.

# Assembly Instruction

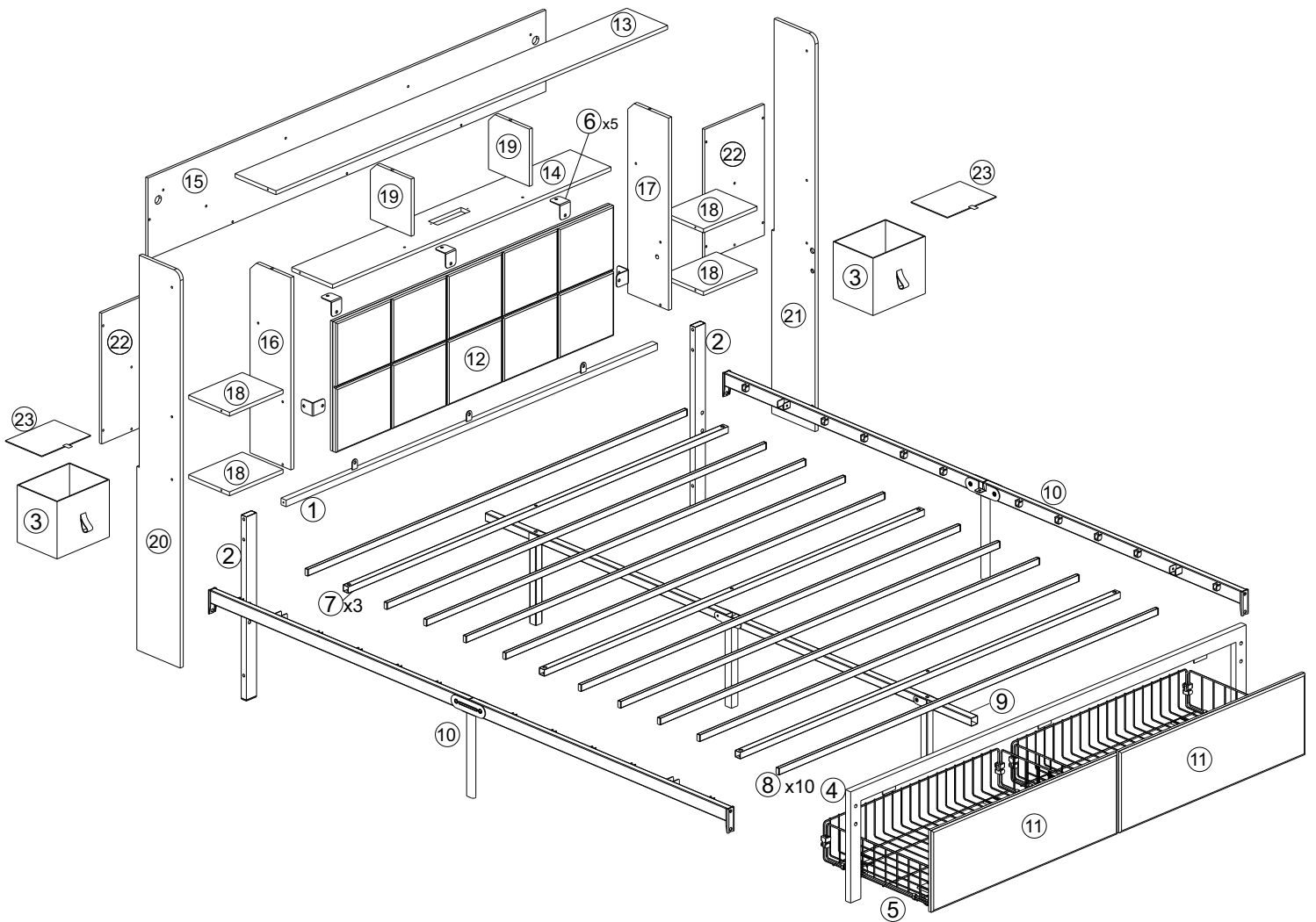

## Important Note

### HARDWARE NOTE :

1. Two or more people are required for assembly
2. Do not screw on the bolts too tight unless the installation is done. Make sure all bolts are tightly screwed before you use it.

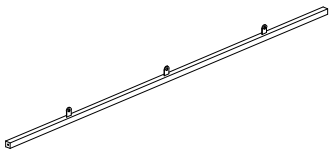

① × 1pc

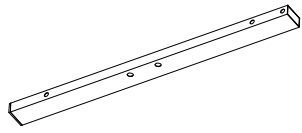

② × 2pcs

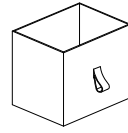

③ × 2pcs

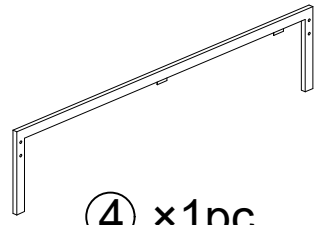

④ × 1pc

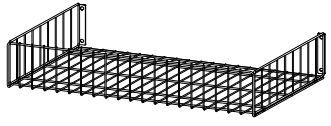

⑤ × 2pcs



⑥ × 5pcs

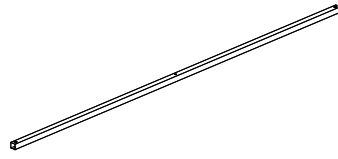

⑦ × 3pcs

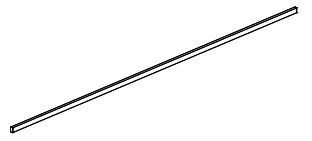

⑧ × 10pcs

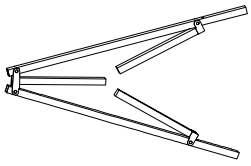

⑨ × 1pc

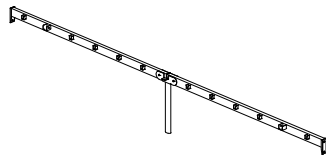

⑩ × 2pcs

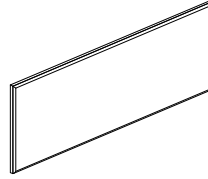

⑪ × 2pcs

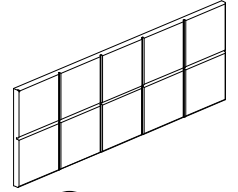

⑫ × 1pc

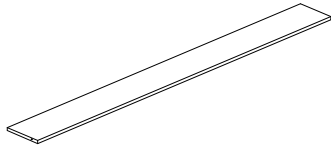

⑬ × 1pc

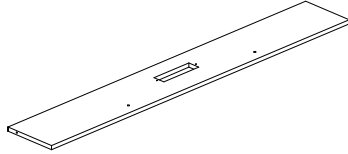

⑭ × 1pc

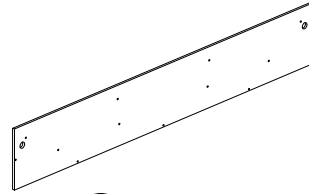

⑮ × 1pc

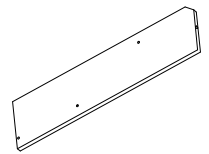

⑯ × 1pc

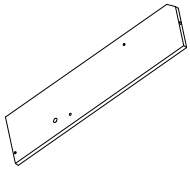

⑰ × 1pc

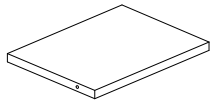

⑱ × 4pcs

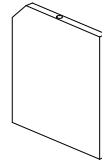

⑲ × 2pcs

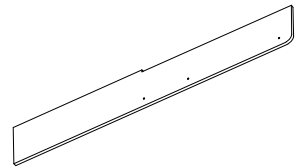

⑳ × 1pc

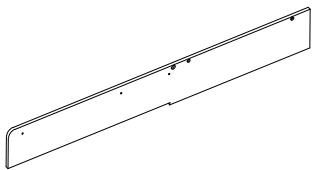

㉑ × 1pc

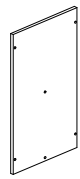



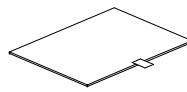





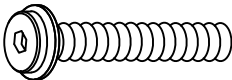
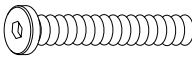
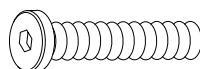
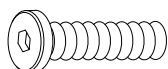

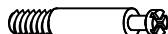

㉒ × 2pcs

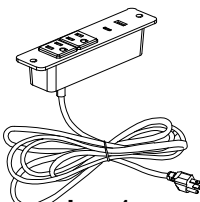
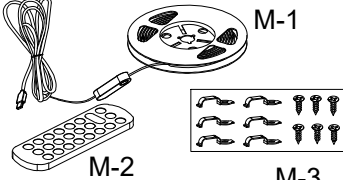

㉓ × 2pcs

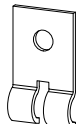
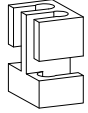
# Hardware

 <p>M8×40mm A×8pcs+1pc</p>	 <p>M6×60mm B×5pcs+1pc</p>	 <p>M6×48mm C×4pcs+1pc</p>	 <p>M6×32mm D×6pcs+1pc</p>
 <p>M6×15mm E×18pcs+1pc</p>	 <p>M6×10mm F×5pcs+1pc</p>	 <p>M5×40mm G×39pcs+2pcs</p>	 <p>M6×35mm H×4pcs+1pc</p>
 <p>Ø15×10mm I×4pcs+1pc</p>	 <p>J-1 3MM 4MM J x 1pc</p>	 <p>M3.5×12mm K×2pcs+1pc</p>	 <p>L×1pc</p>
 <p>M-1 M-2 M-3 M×1pc</p>	 <p>N×1pc</p>	 <p>O×2pcs</p>	 <p>R×4pcs+1pc</p>
 <p>S×8pcs</p>			

1



M5×40mm

G×2pcs

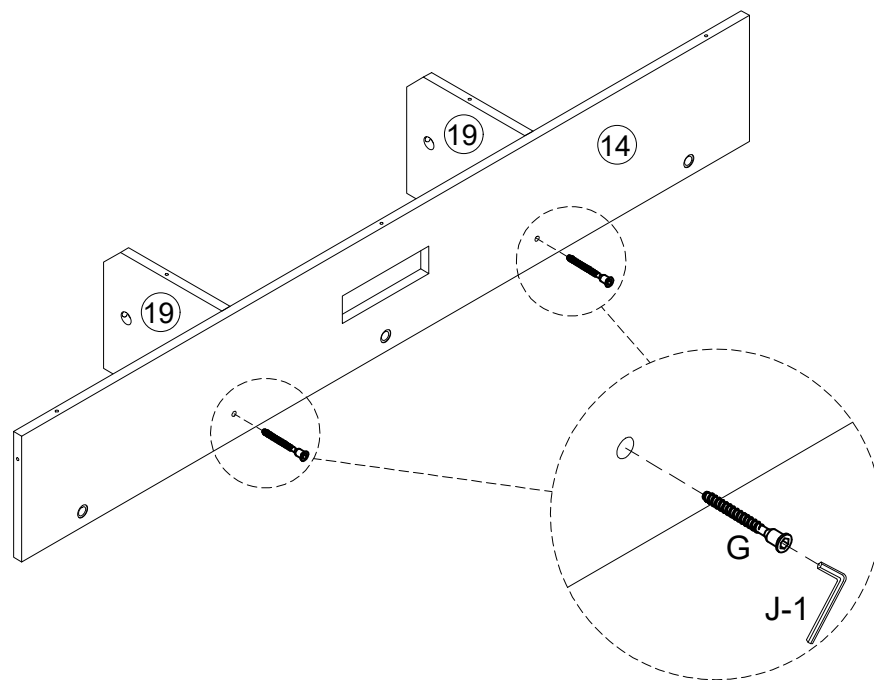

2



M5×40mm

G×2pcs

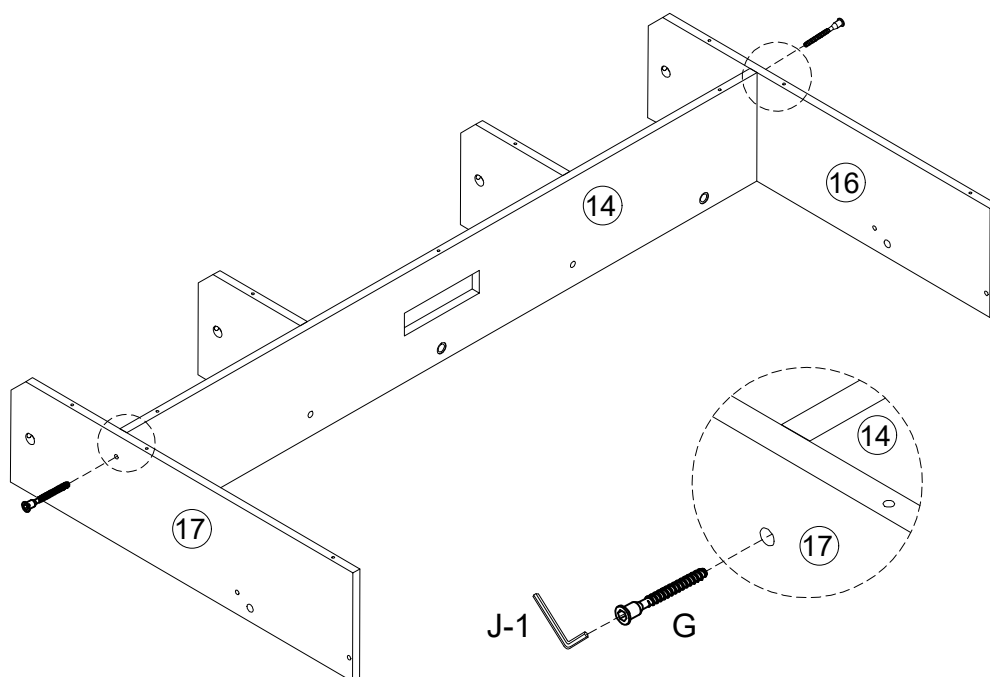

# 3



M5×40mm

G×4pcs

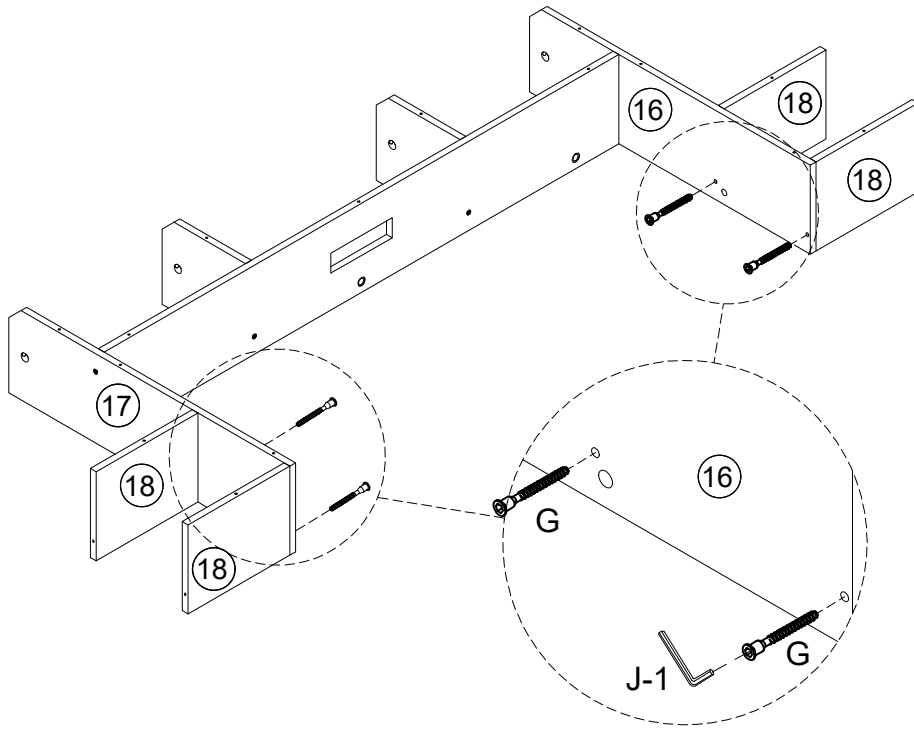

# 4

Step 1

Tear double-sided adhesive tape apar

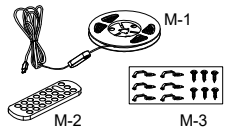

M×1pc

Step 2

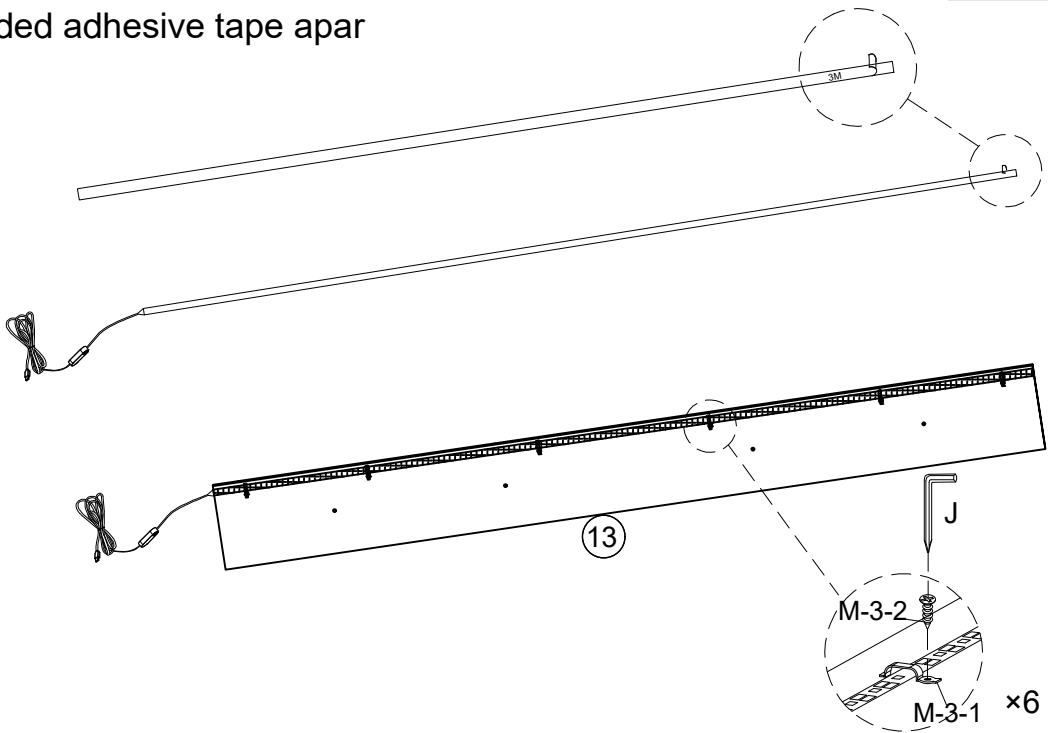

5

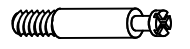

M6×35mm

H×4pcs

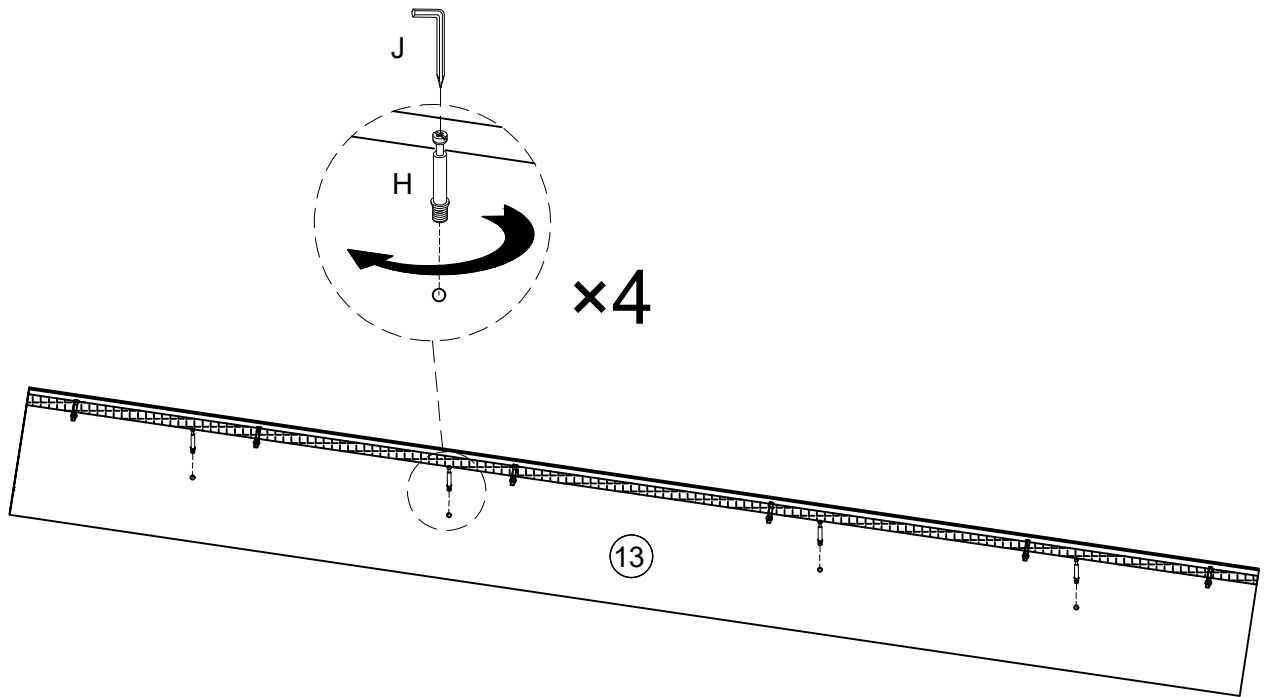

6



Ø15×10mm

I×4pcs

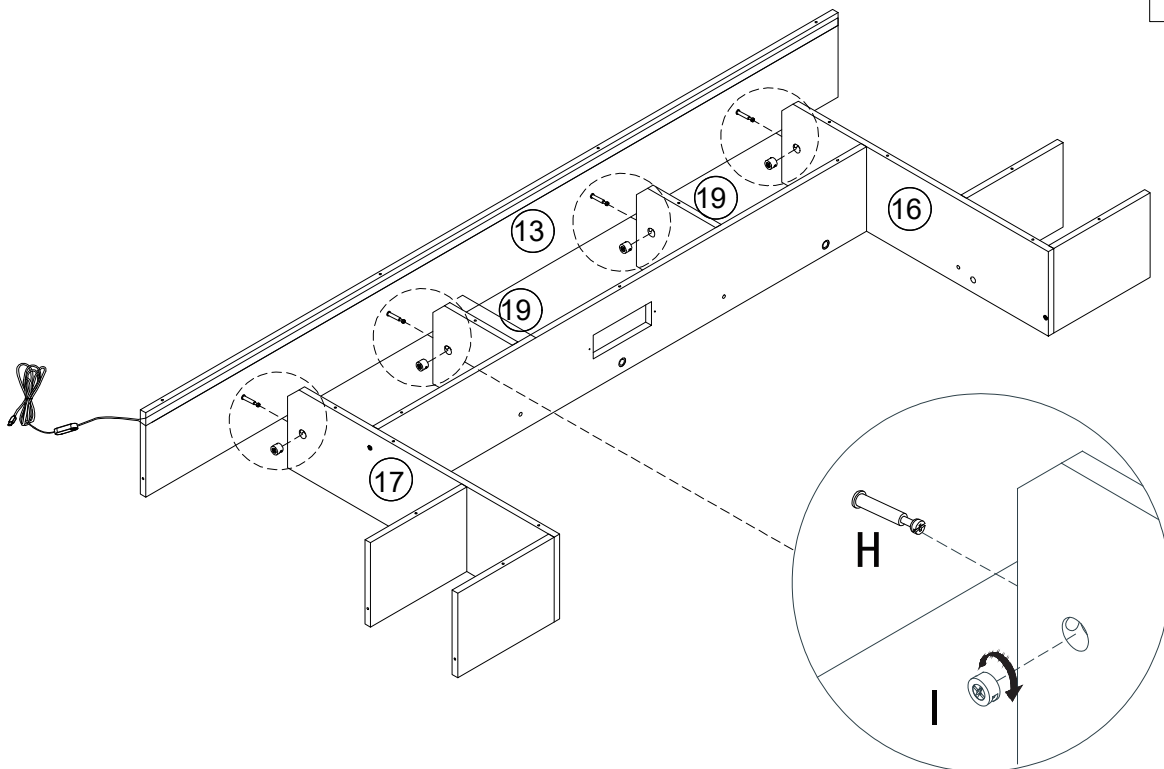

7

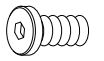

M6×10mm  
F×5pcs

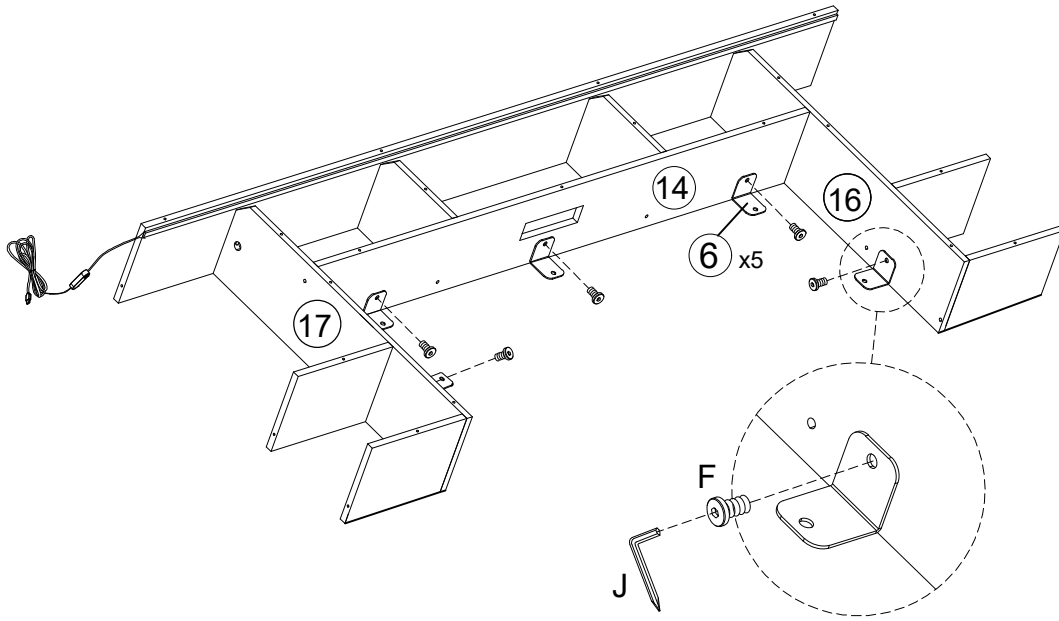

8

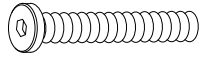

M6×60mm  
B×2pcs

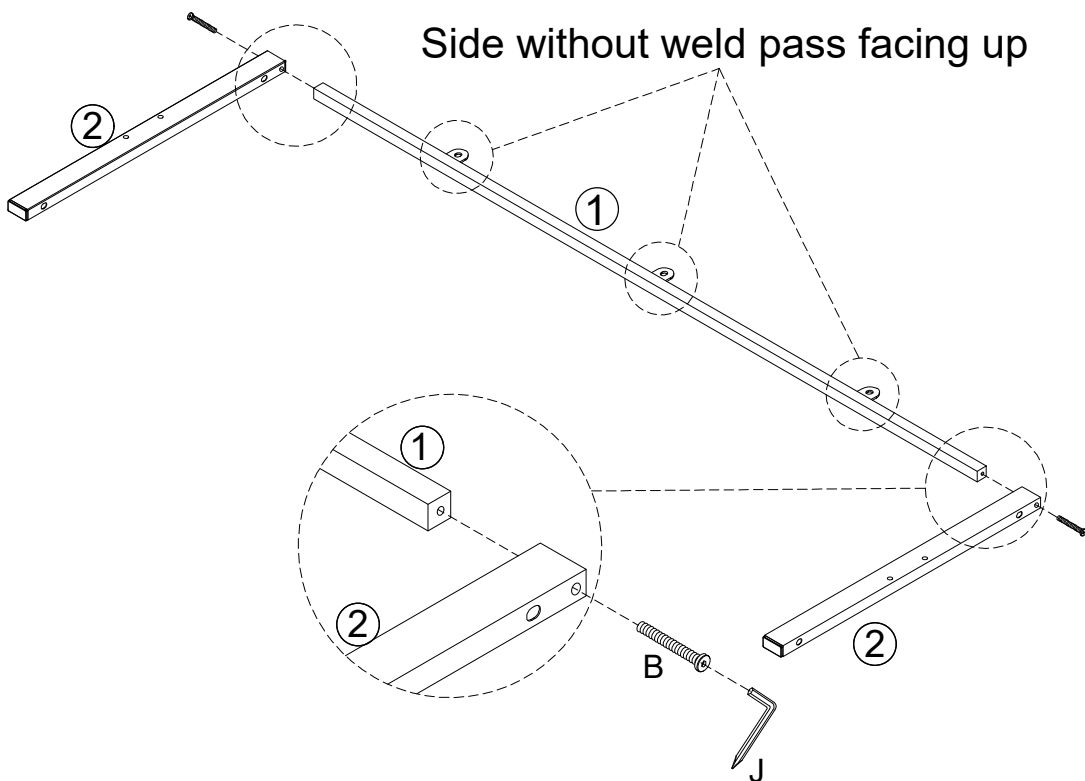

9

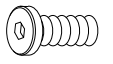

M6×15mm  
E×8pcs

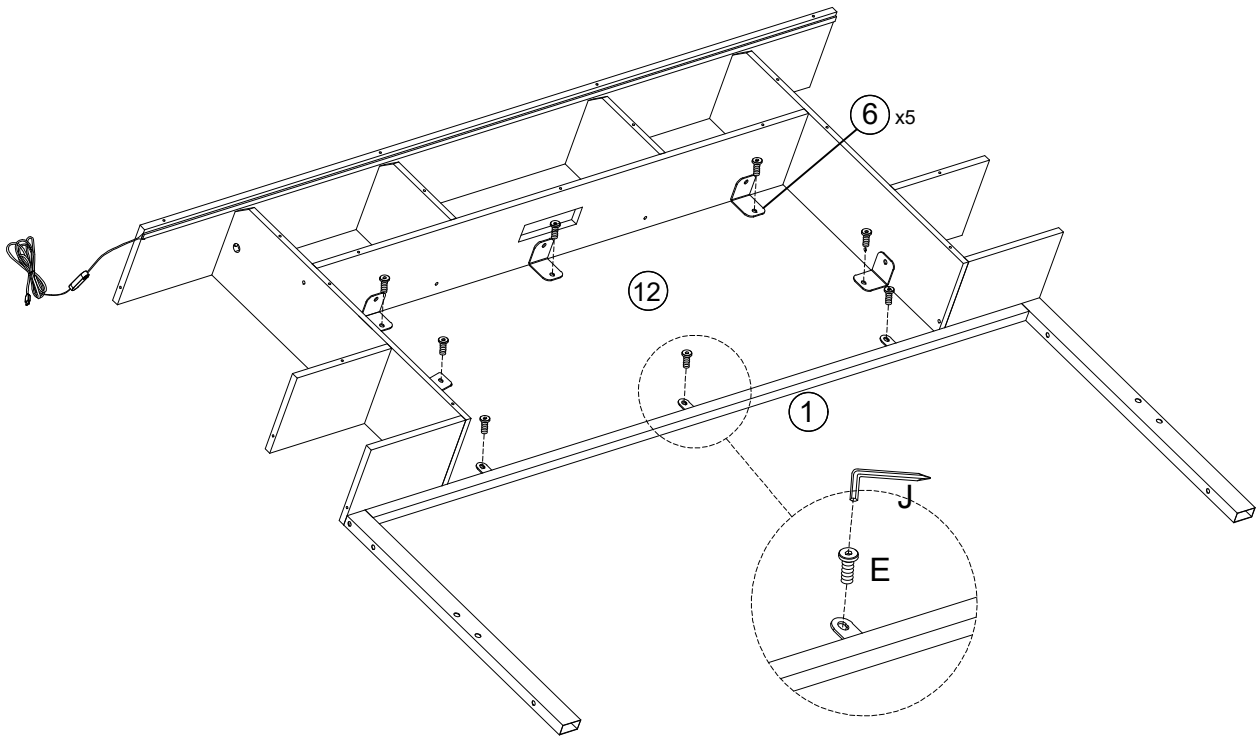

10



M5×40mm  
G×11pcs

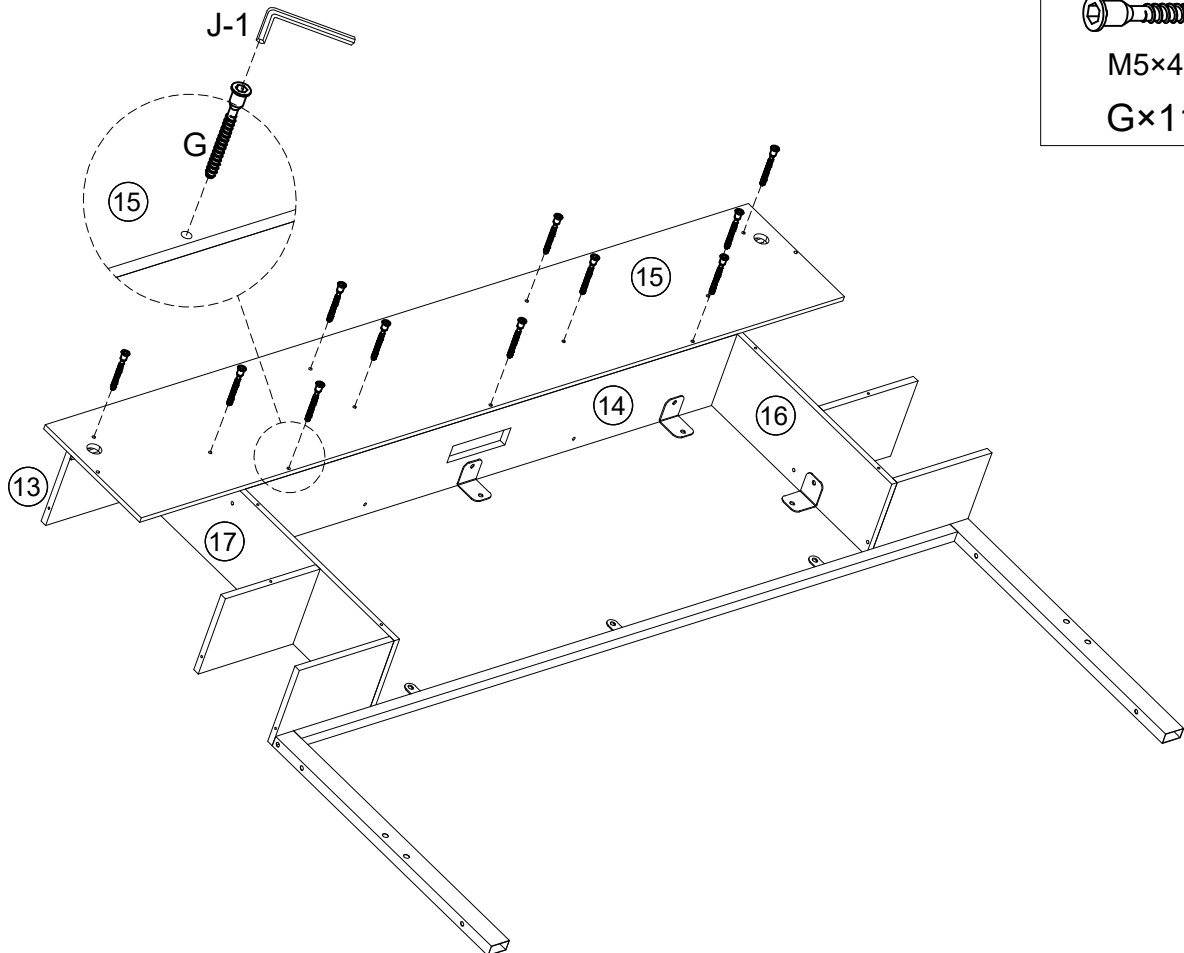

# 11

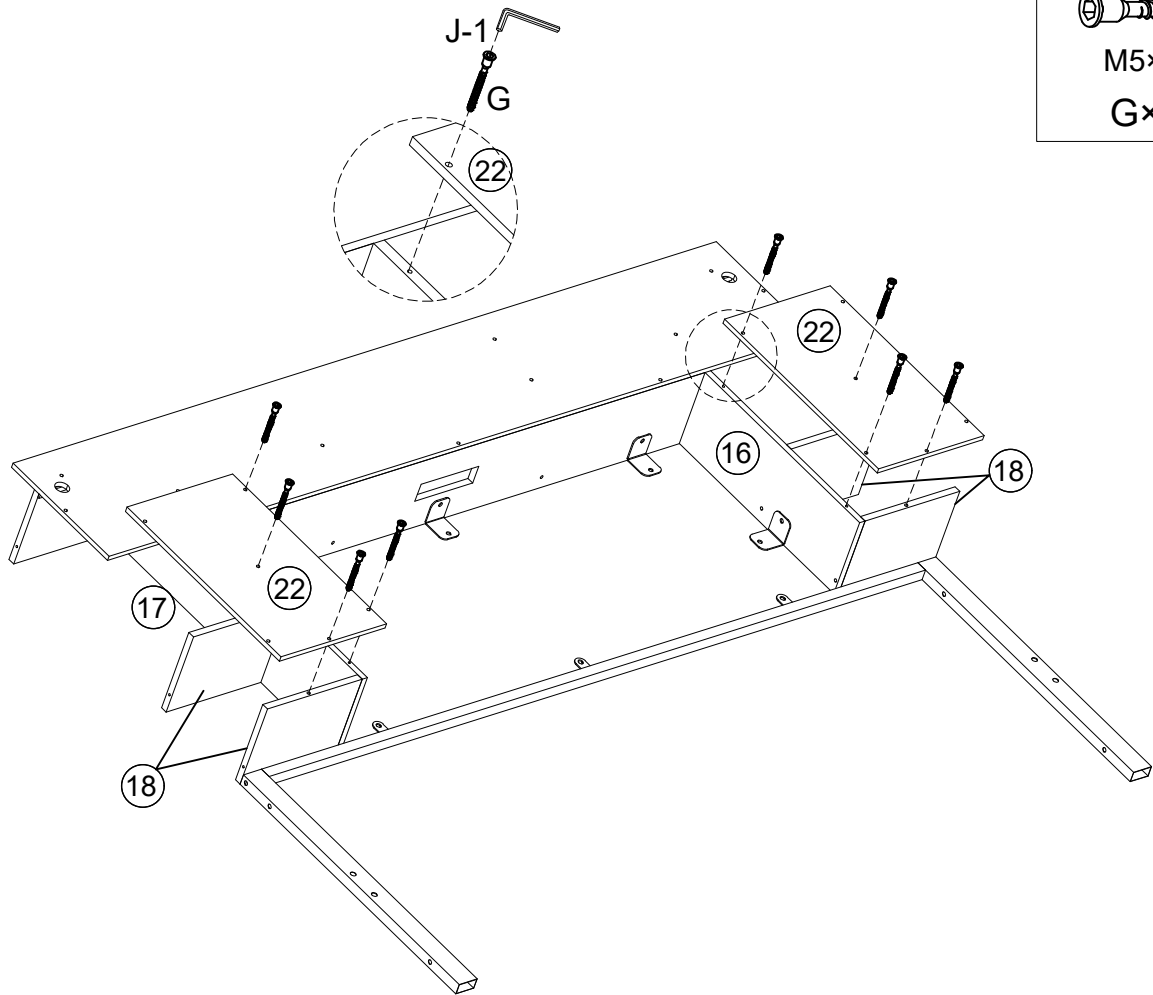

M5×40mm

G×8pcs

# 12

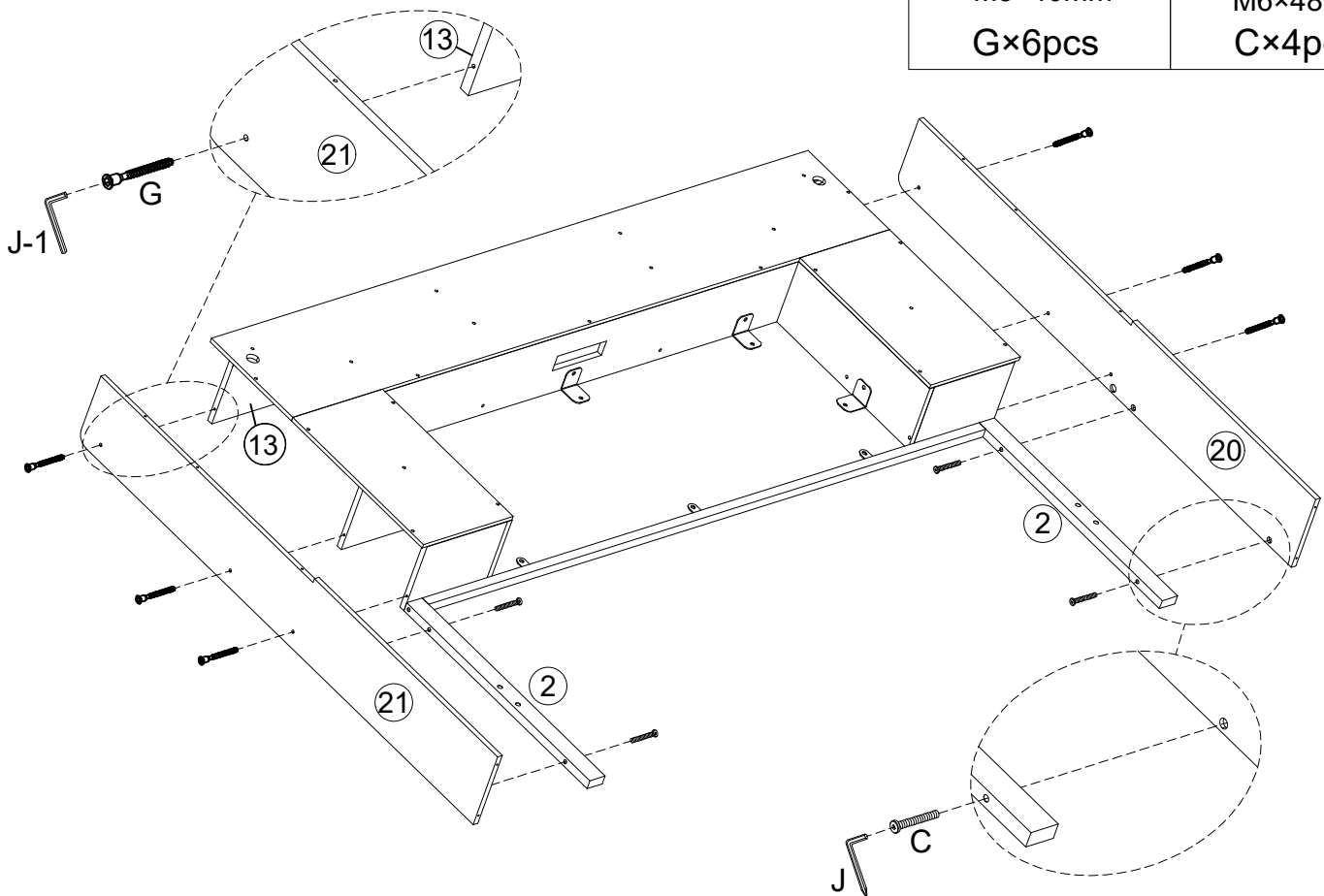

M5×40mm

G×6pcs

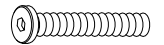

M6×48mm

C×4pcs

# 13

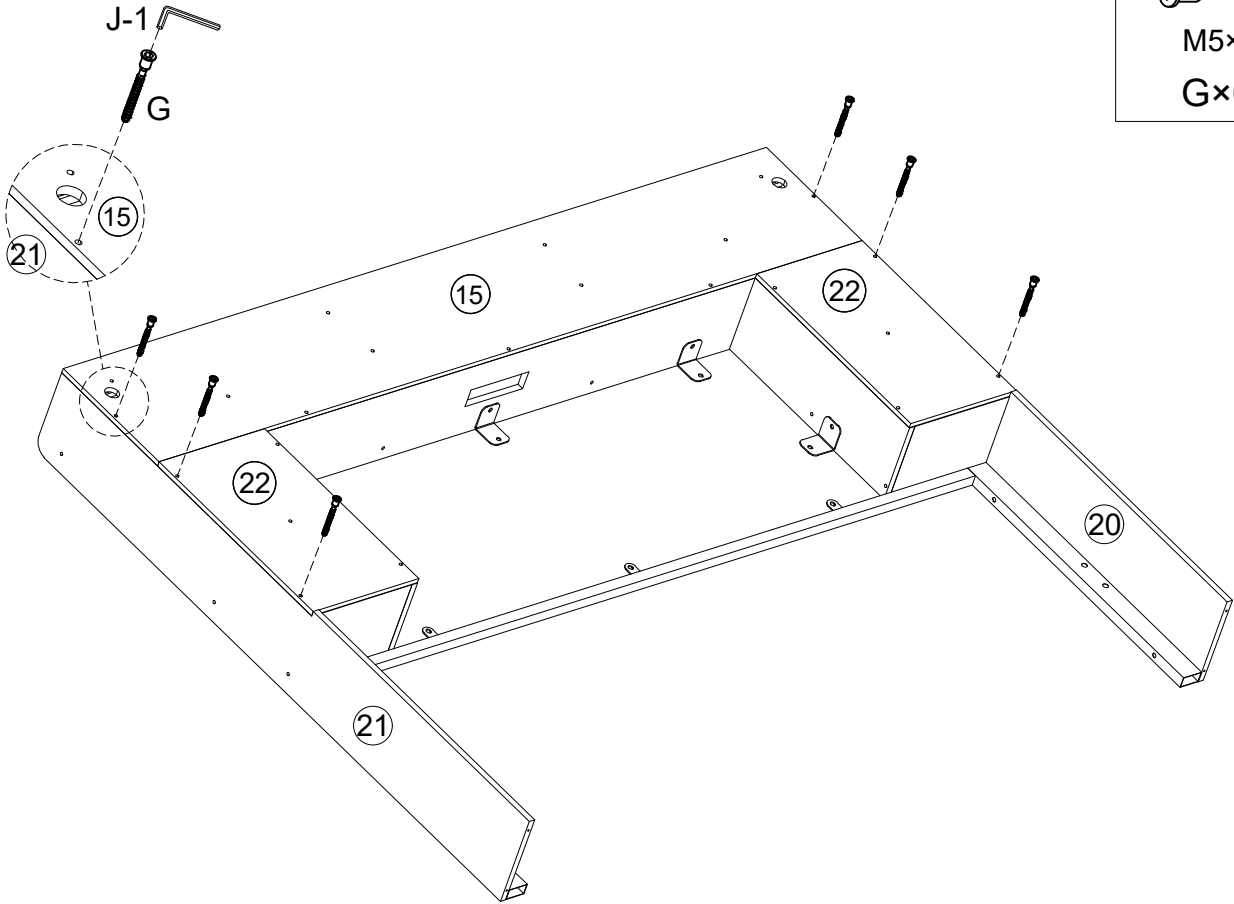

M5x40mm

Gx6pcs

# 14

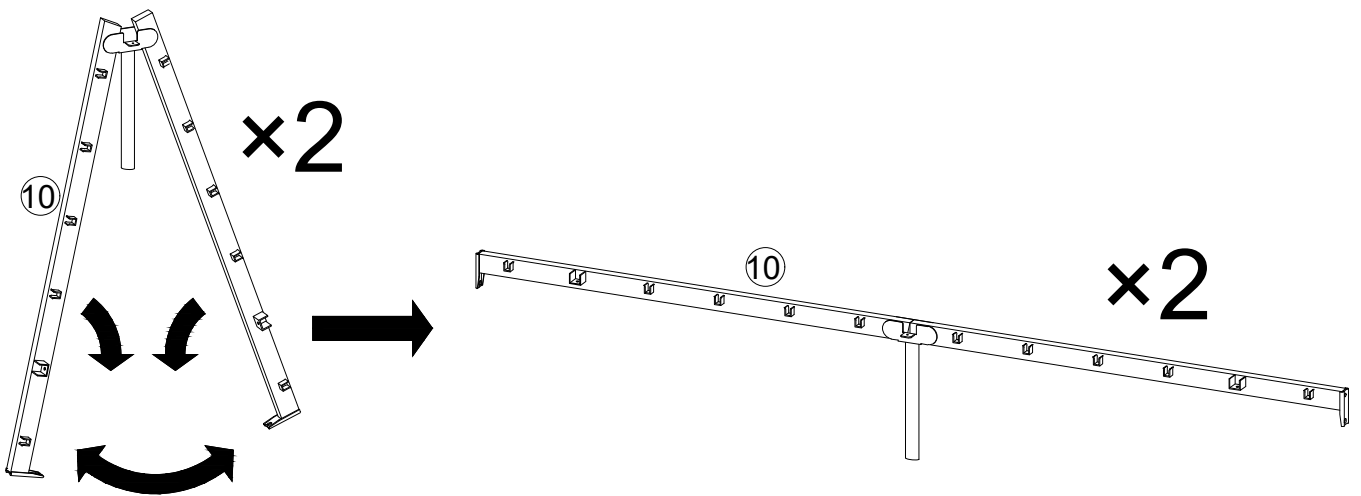

# 15



M8x40mm  
Ax4pcs

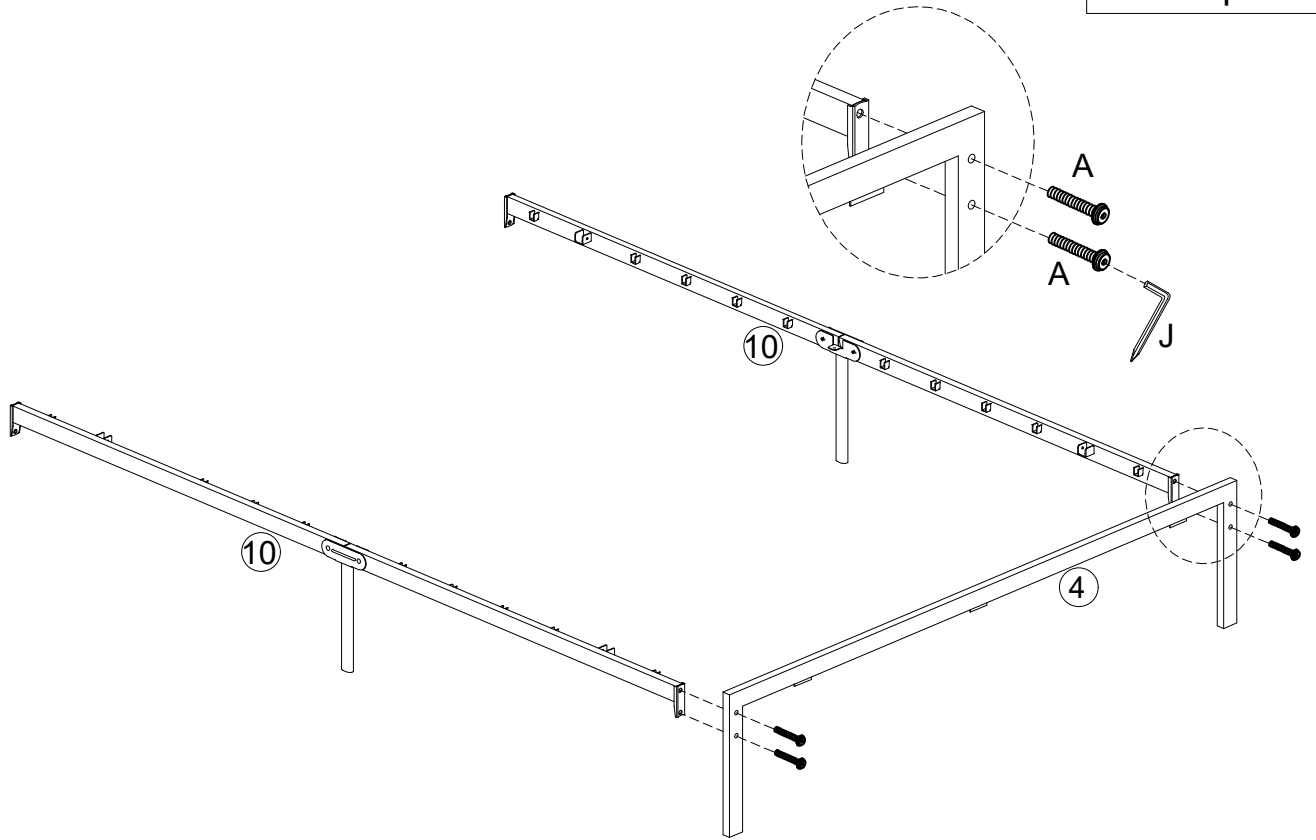

# 16



M8x40mm  
Ax4pcs

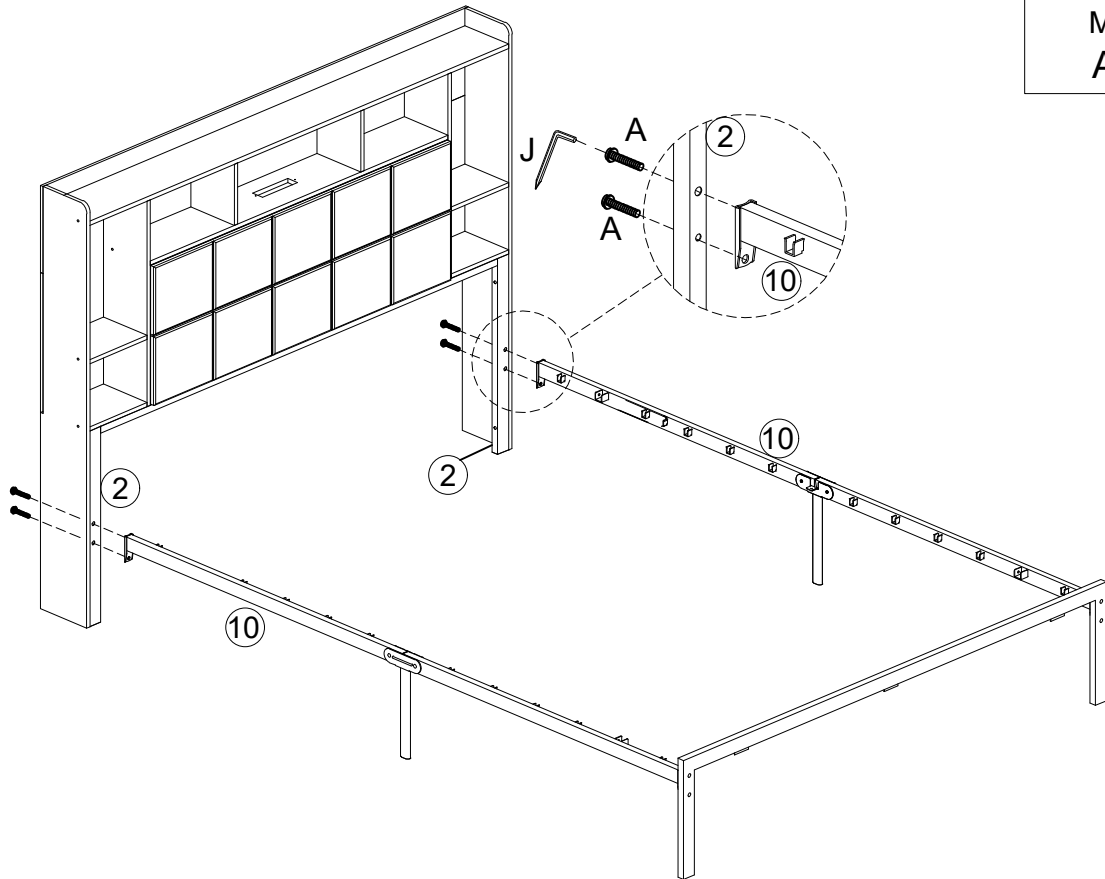

# 17



L×1pc



M3.5×12mm

K×2pcs

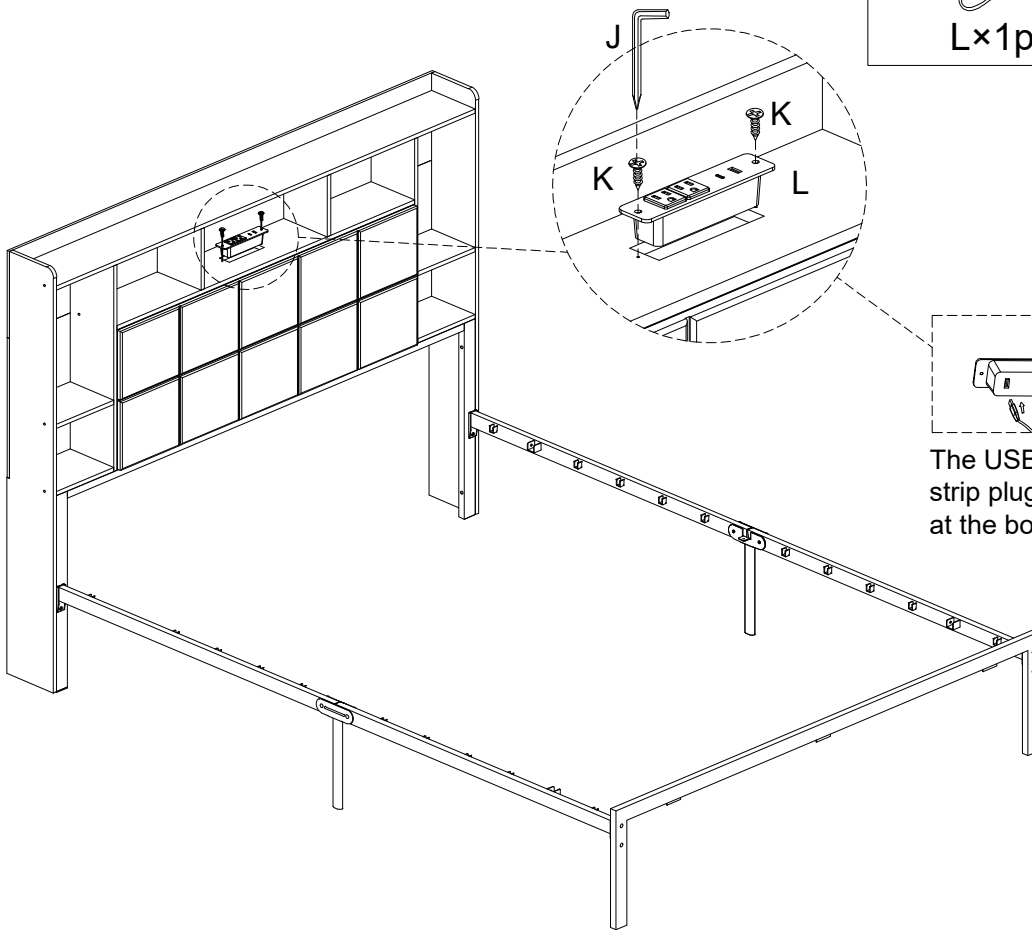

# 18

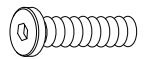

M6×32mm

D×6pcs

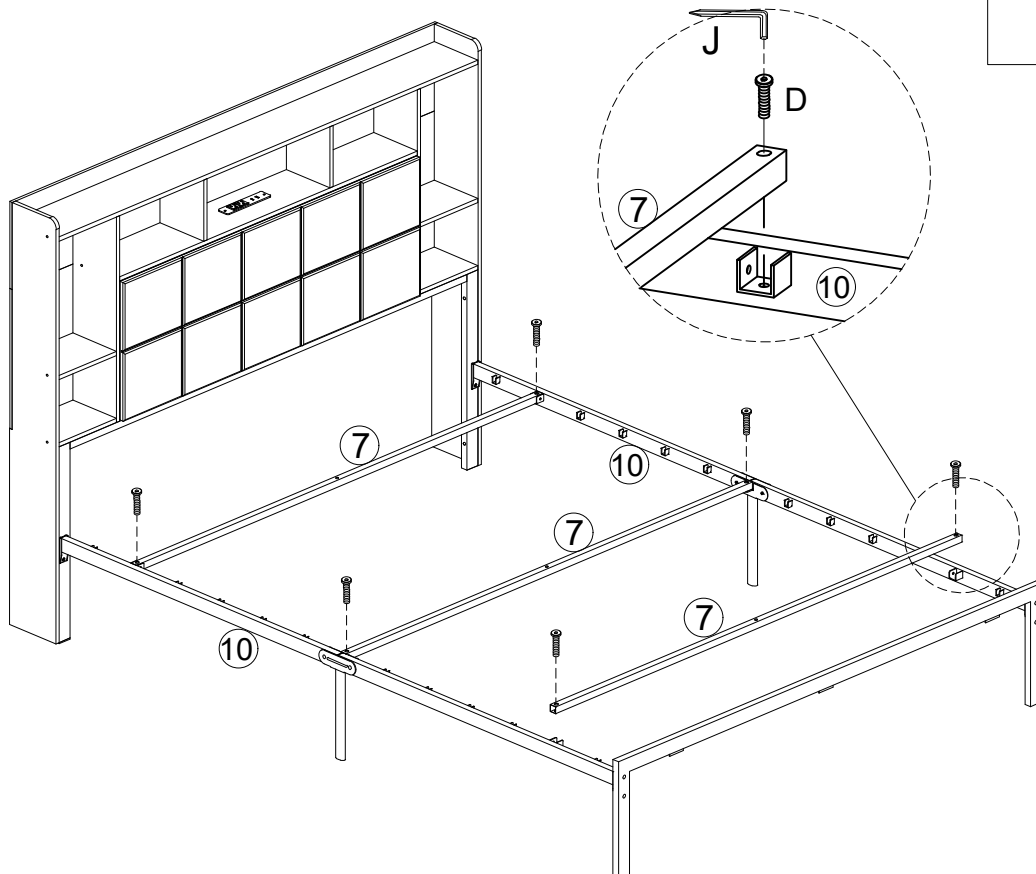

# 19

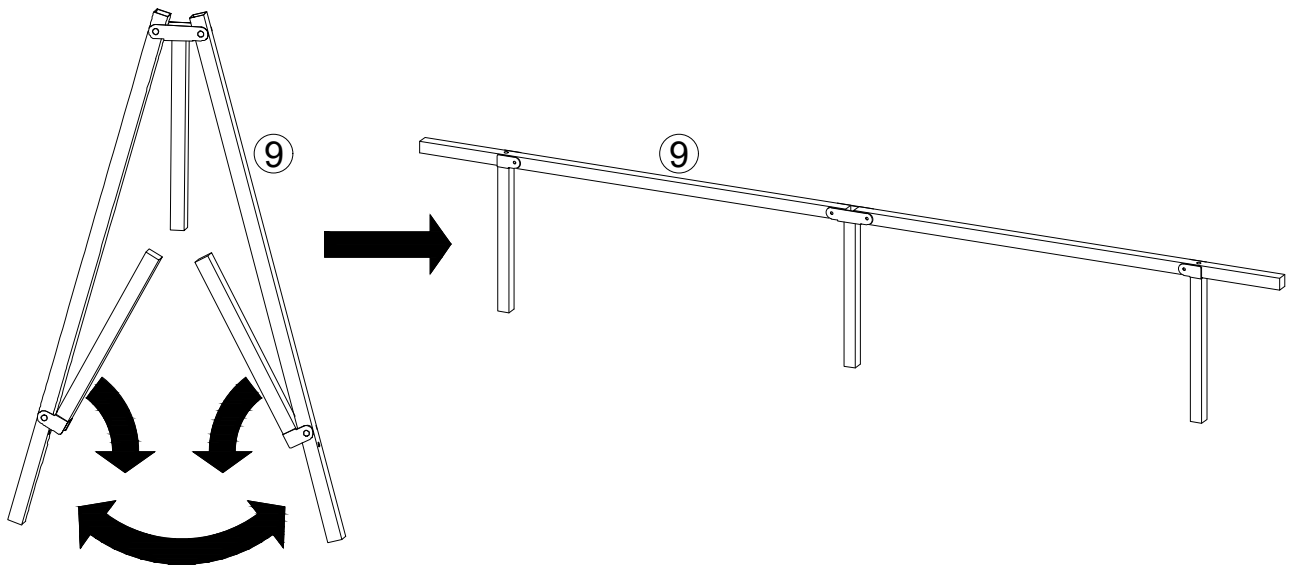

# 20

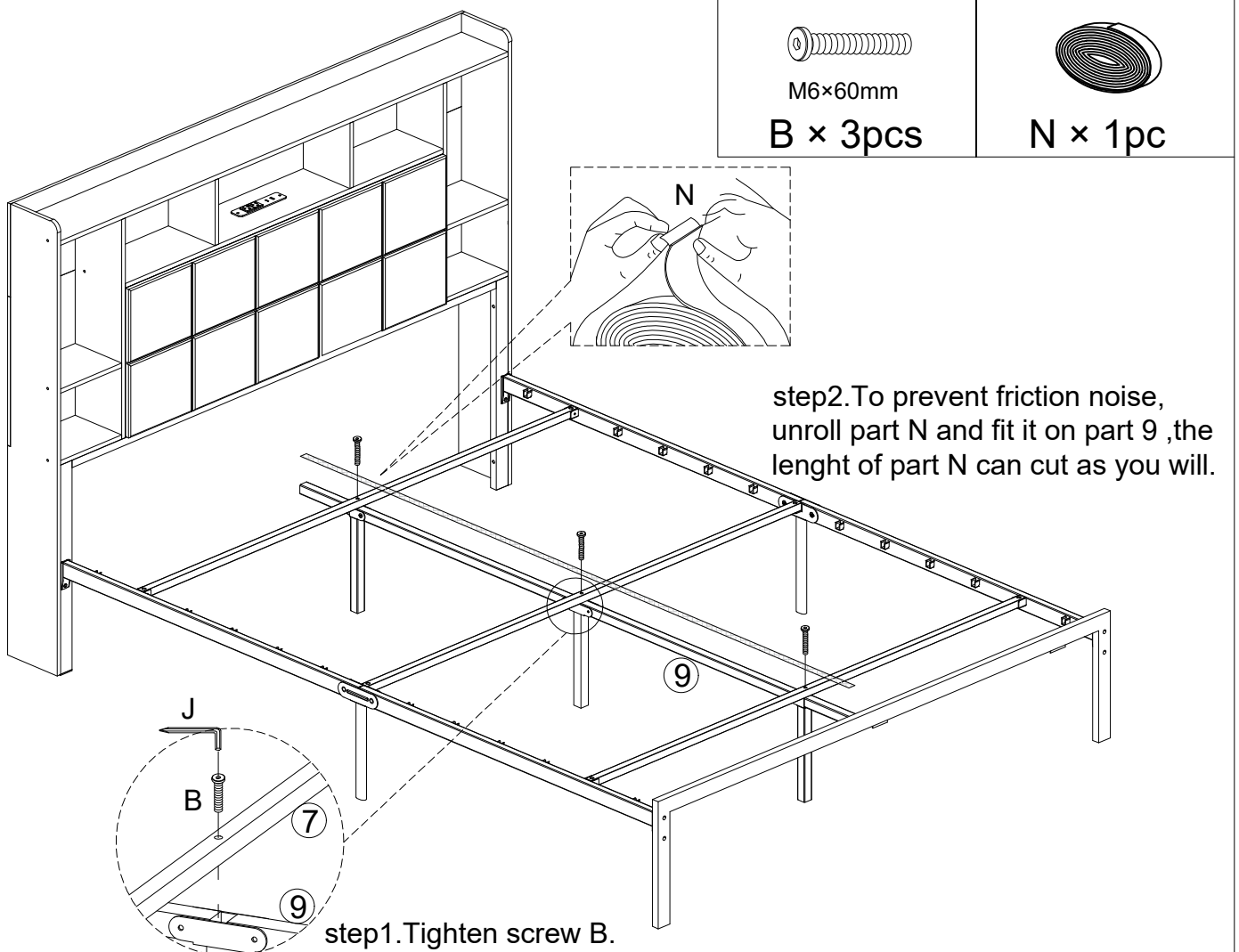

21

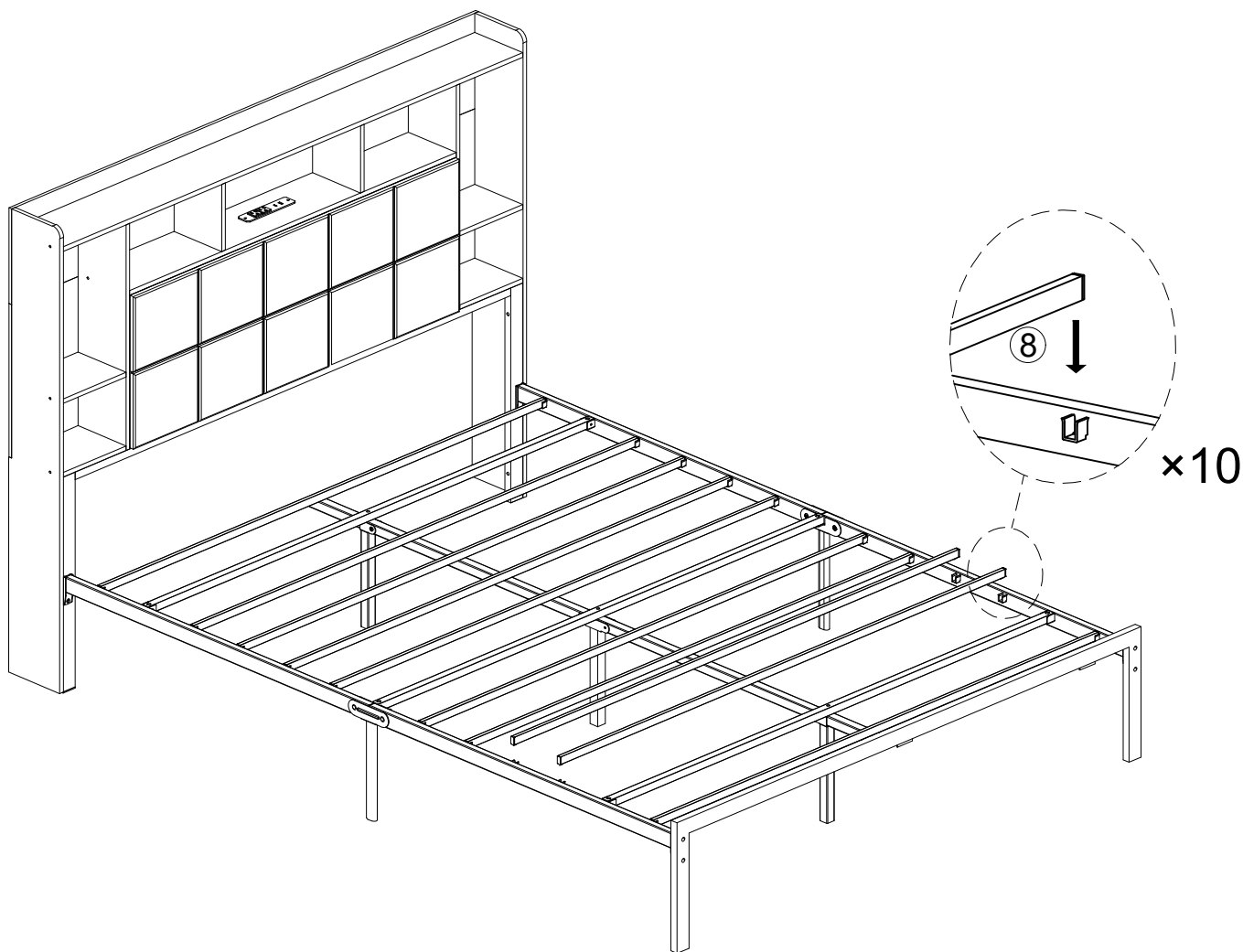

22



R  $\times$  4pcs

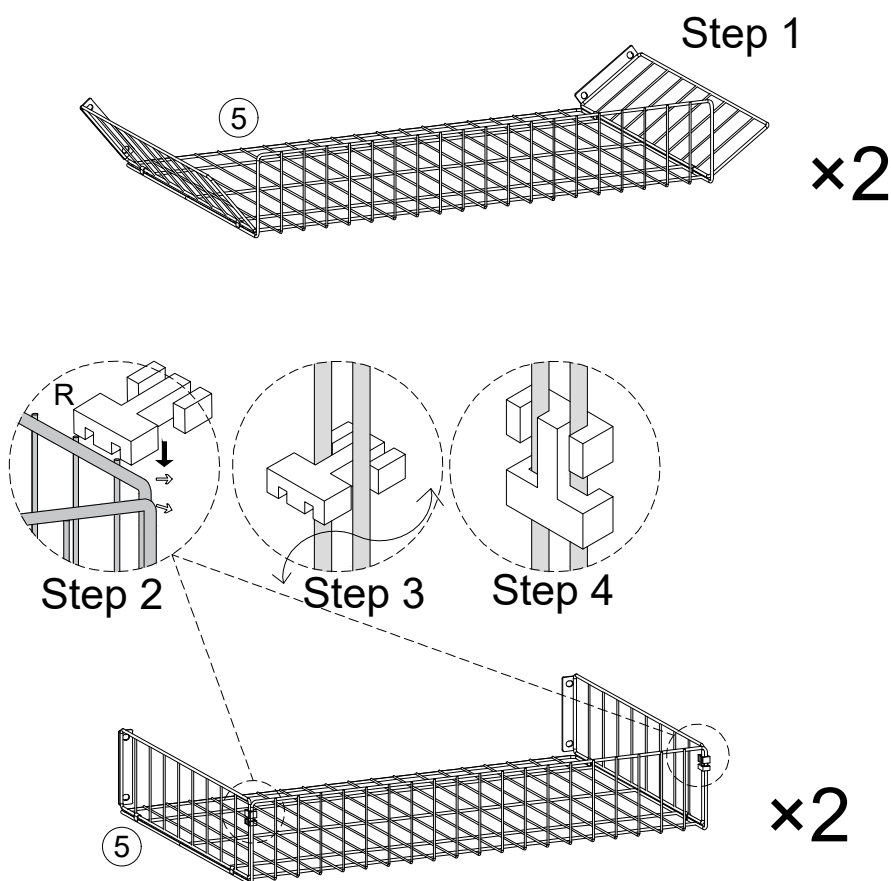

# 23



M6×15mm  
E×10pcs

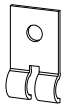

O × 2pcs

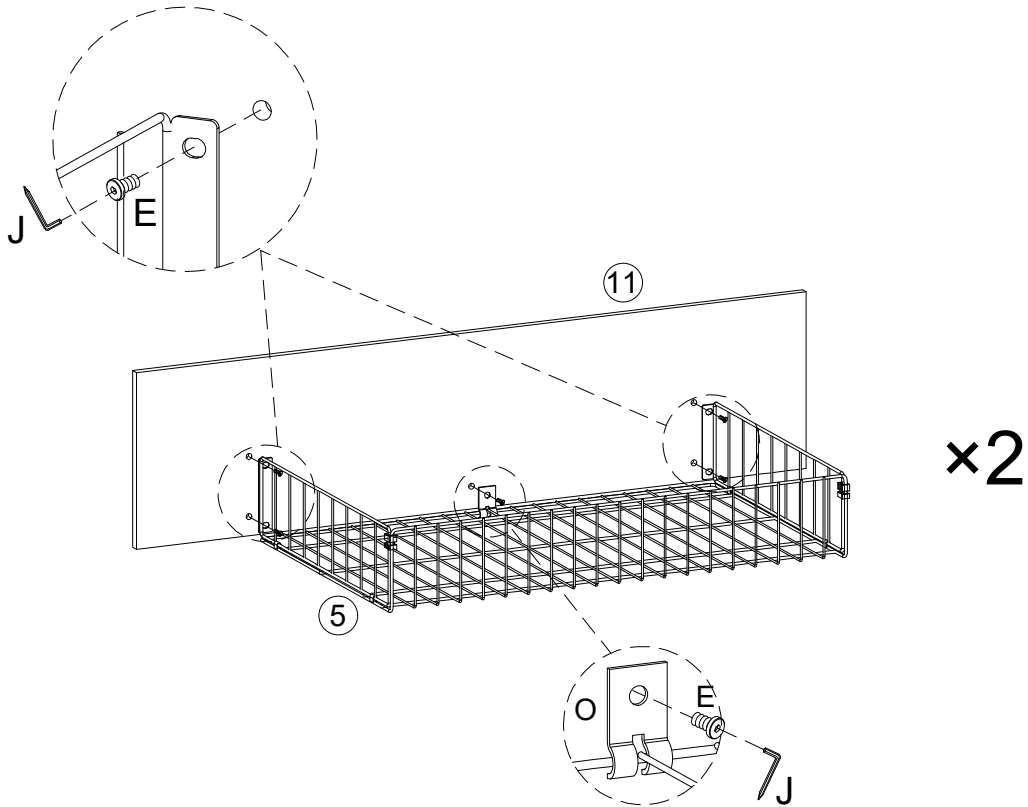

# 24



S × 8pcs

Clamp the wire with the opening of the front end of the wheel and press down to tighten the wire.

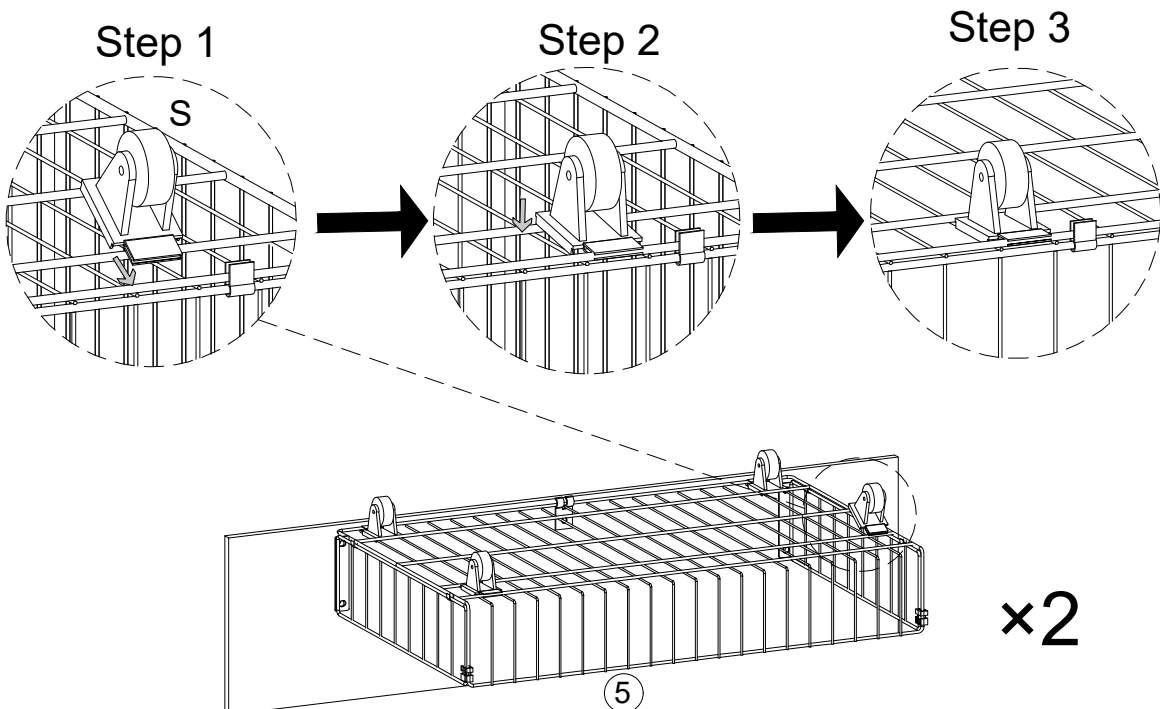

25

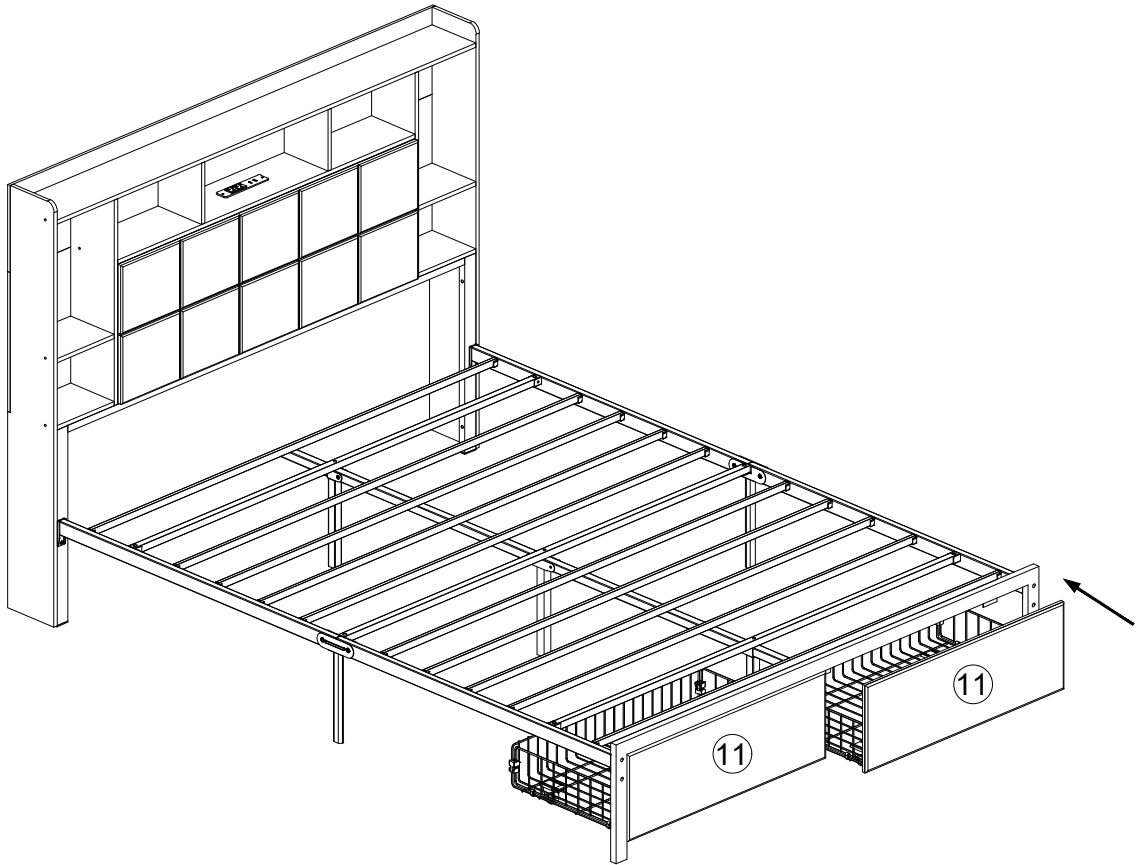

26

