

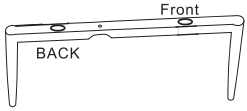





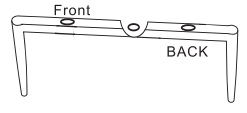
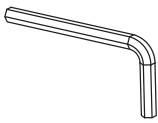

Assembly Instruction

<p>AX1</p> 	<p>GX5</p> 
<p>BX1</p> 	<p>HX1</p> 
<p>CX1</p> 	<p>IX1</p> 
<p>DX1</p>  <p>M6X30mm</p>	<p>JX5</p>  <p>M6X25mm</p>
<p>EX4</p>  <p>M6X50mm</p>	<p>FX5</p> 

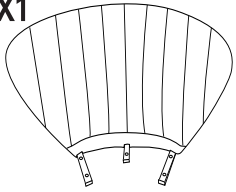
1

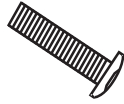
The backrest needs to be pressed down to align with the hole, and then the screws can be tightened in.

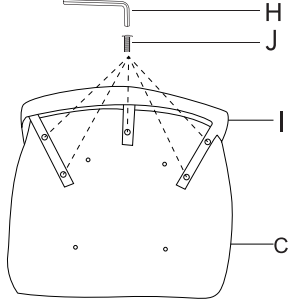

2

Use bolt D, spring washer G, flat washer F, allen wrench H to connect metal leg part A and B together, don't fasten the bolt at this stage.

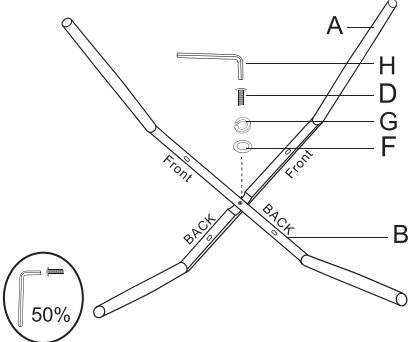

3

Use bolt E, spring washer G, flat washer F, allen wrench H to attach the whole metal leg assembly to bottom of the seat.

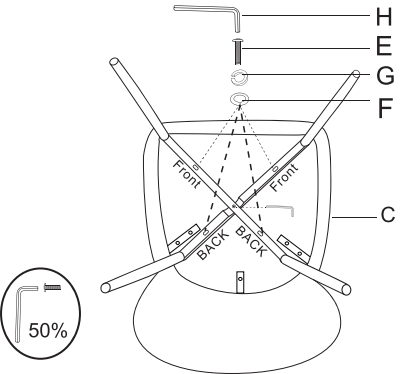

4

Make sure all holes on legs align with holes on bottom of seat then fasten all bolts to secure.

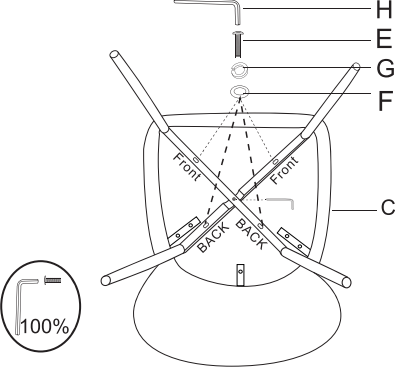

5

Adjust levelers under legs to swt the seat level

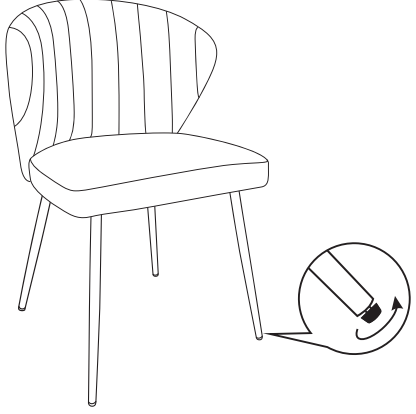

6

