

INSTALLATION INSTRUCTIONS

DeerValley®

Sliding Shower Door

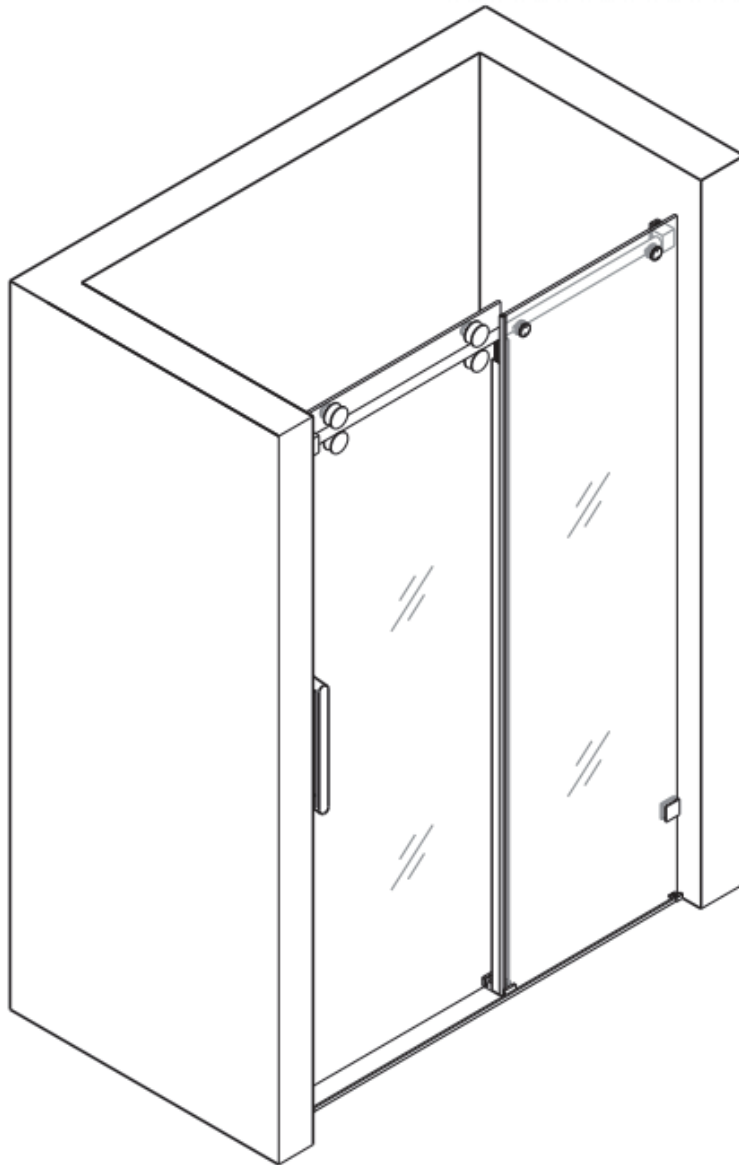

Watch the Installation Video

SCAN THE QR CODE BELOW TO WATCH THE STEP-BY-STEP INSTALLATION GUIDE

This video provides a detailed demonstration to help you complete the installation.



 <https://youtu.be/daqWIGJM6HM?si=57Tt0XBjGSAX5b-g>

If the QR code doesn't work, please enter this URL in your browser.

TIP : We recommend watching the full video before starting the installation.

Product Breakdown Diagram

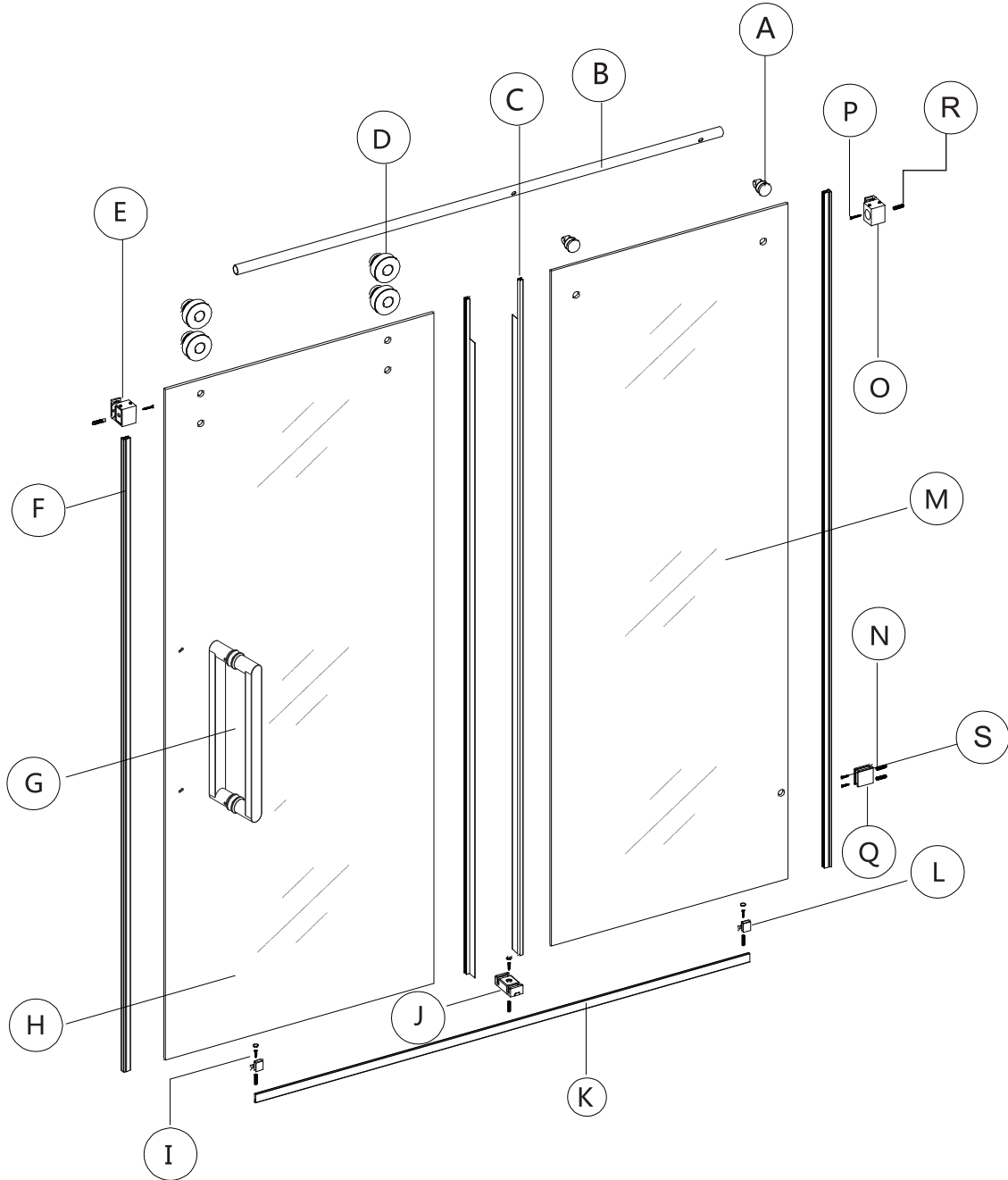
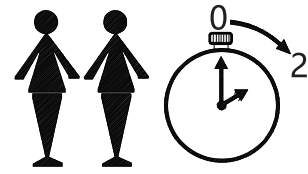

If you have any questions or concerns

Please contact us:

(312) 626-9466

service@deervalleybath.com

PREPARATION FOR INSTALLATION



Read all instructions before unpacking the product.

Caution!



At least 2 people are required to lift and install this product safely.

- We reserve the right to change, update, modify, alter, or redesign this manual, product, or its policies without prior notice.
- It is your responsibility to visit our website to download, or contact customer service for, the most updated version of the installation instructions.
- We shall not be liable for any injuries or property damage that may occur during the installation or use of this product.

Important Unpacking Instructions

1. Open the carton carefully. Do not remove the shower glass doors or panels until you have read these instructions.
2. Prepare a soft cloth blanket, at least 1/4 inch thick, larger than the glass doors or panels. Place it on your working area floor.
3. Remove the glass doors or panels from the carton and place them carefully on the soft cloth blanket. Do not lean the glass against walls or floors without protection.

Attention!

- Never place glass doors or panels directly on tile, concrete, or any hard surfaces. Always use a soft cloth blanket or protective surface under the glass. Placing glass without protection can cause scratches on the tempered glass, which may lead to shattering immediately, during installation, or during use.
- Improper handling can scratch or damage the glass doors or panels. Always inspect all glass doors and panels carefully before installation.
- Do not install any glass that has scratches or chipped corners. Stop the installation if any damage is found.
- Never set glass on its corners. Make sure the floor is level and fully covered with the soft cloth blanket when preparing the glass doors or panels for installation.

Pre-Installation Checks

1. After opening all packages, check that all parts and components are included by referring to the parts diagram.
2. Inspect boxes and packaging for shipping damage. If parts are missing or damaged, contact customer support immediately.
3. Double-check all corners and edges of every glass door and panel. Installation must not proceed if any damage is found.

INSTALLATION INSTRUCTIONS

Important!

Consult your local building and plumbing codes regarding installation compliance. Building codes vary by state and location. We are not responsible for code compliance and do not accept returns for code-related issues.

Installation Requirements

- Ensure the installation surface is level and solid, able to support the total weight of the unit.
- Walls must be at the correct angles. Uneven surfaces or angled walls can cause serious installation problems.
- Some adjustments and drilling will be necessary during installation.
- The wall must have a minimum 2" x 4" wood stud framing behind it to support this heavy product.

Safety Instructions

Failure to follow these instructions could result in serious injury or death due to improper handling or incorrect installation of this product. These instructions must be observed for safe and proper installation.

- A licensed and insured professional contractor is required for installation, with assistance from a second person.
- Do not modify the product in any way. Modifications can cause serious injury or damage.
- Do not install the handle on the glass until instructed. Never lift glass using the handle; doing so can cause injury or breakage.
- Use professional-grade glass suction cups for handling heavy glass panels.
- Install this product only on finished thresholds and against finished walls.
- This product is intended for residential use only.

Delivery Notes

Upon receiving the product, please immediately inspect for any transportation damage, missing parts, or manufacturing defects.



Cleaning and Maintenance

1. For daily cleaning of the product, you can use common liquid detergent and a soft cloth.
2. For stains, use a clean soft towel or a small amount of neutral soap solution or toothpaste to gently wipe.
3. To keep the glass surface shiny, you can use a polishing agent for polishing treatment.

Precautions

1. Do not use acidic, alkaline, or sharp tools during cleaning to avoid damaging the glossiness of shower trays, glass, metal materials, and other accessories' surfaces.
2. Avoid using strong detergents containing acetone or ammonia ingredients; when disinfecting, avoid using disinfectants containing formic acid and formaldehyde to prevent damage to the product's surface glossiness.
3. Do not allow body or hard objects to come into contact with or impact the glass surface during showering to avoid accidents.
4. Regularly check the usage condition of the product, and if any abnormalities are found, please contact the after-sales service department promptly.

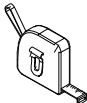
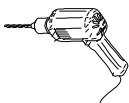
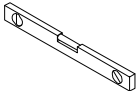
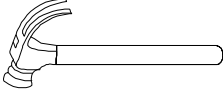
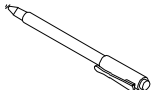
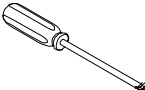
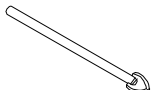
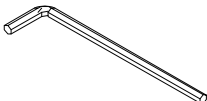
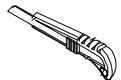
Tool List (Not Included)

Material Name	Illustration	Material Name	Illustration
Tape measure		Electric drill	
Spirit level		Hammer	
Marker pen		Screwdriver	
1/4" drill bit		Allen wrench	
Utility knife		Silicone sealant	

Parts List

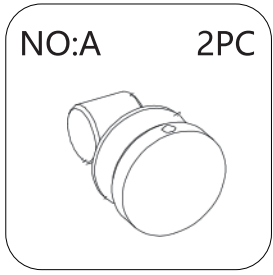

Glass Fixing Components

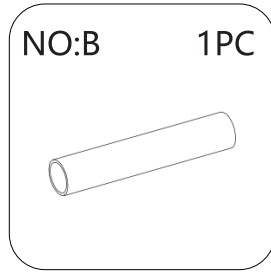

Circular Tube Guide Rail

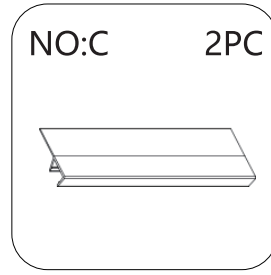

Water Blocking Strip

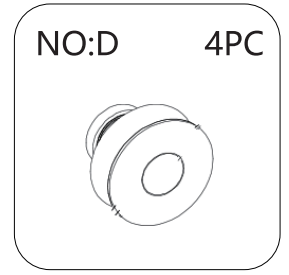

Pulley

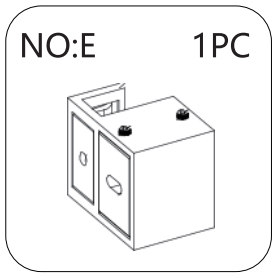

Left Wall Cover

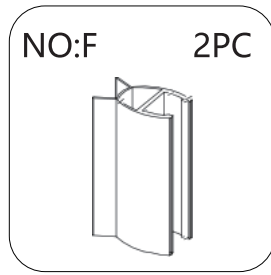

H-Shaped Strip

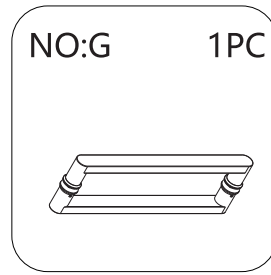

Handle

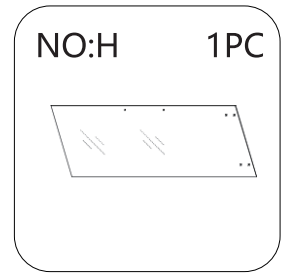

Door Glass

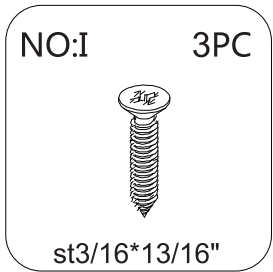

Screw-A

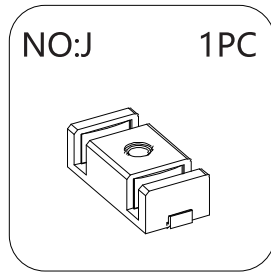

Lower Slider

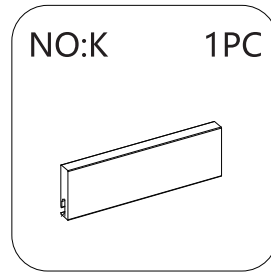

Lower Water Stop Bar

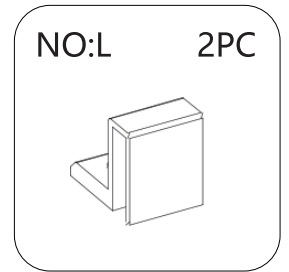

Water Stop Bar Fixing Parts

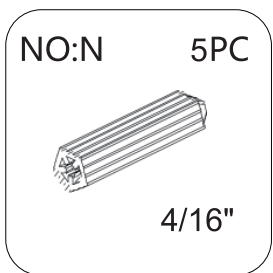

Wall Entry Plug

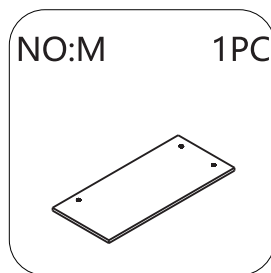

Fixed Glass

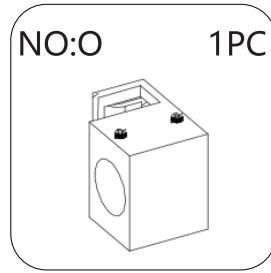

Right Wall Cover



Screw-B

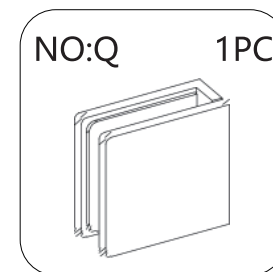

Fixed Clip

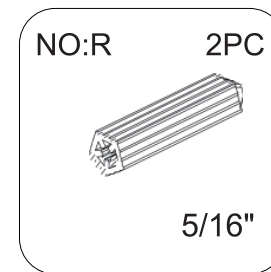

Wall Entry Plug



Screw-c

Drawings may not exactly define contour of the product.

Installation Steps

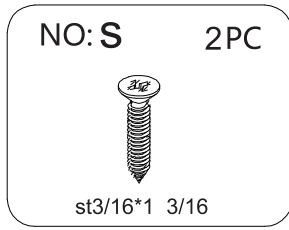

Screw-A

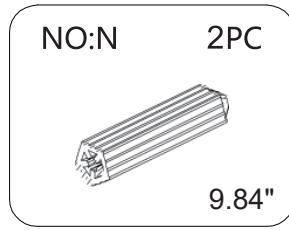

Wall Entry Plug

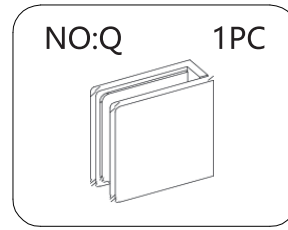

Fixed Clip

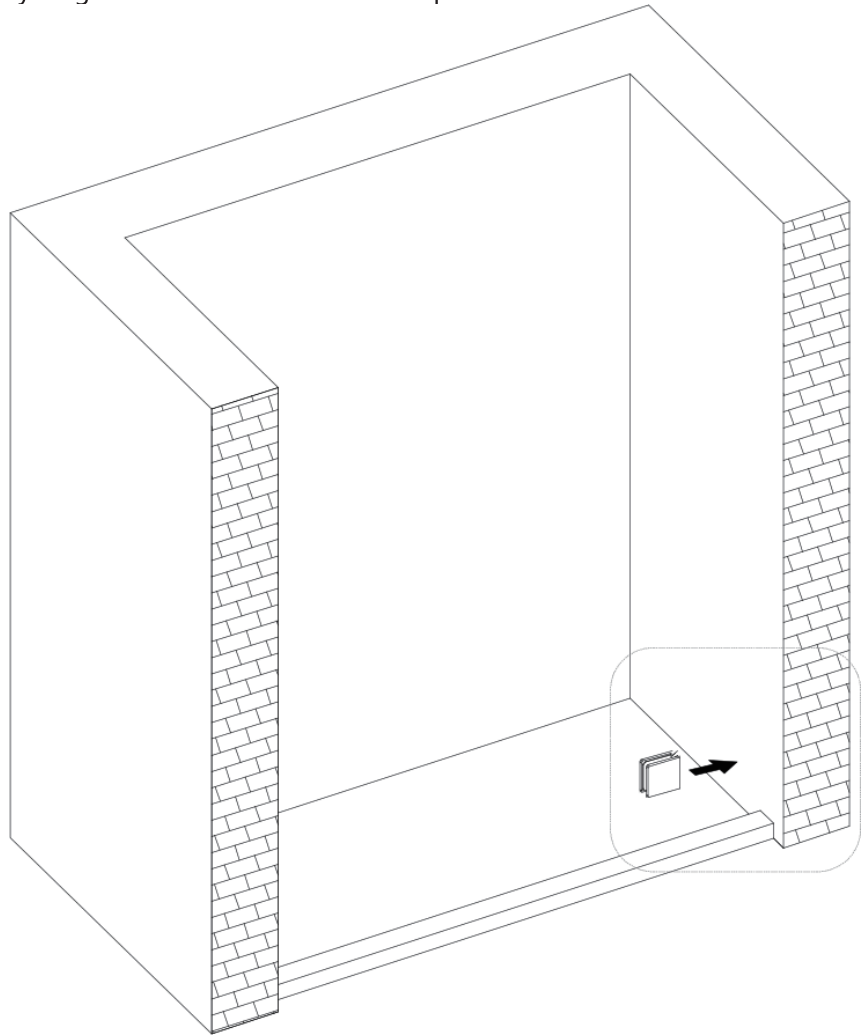
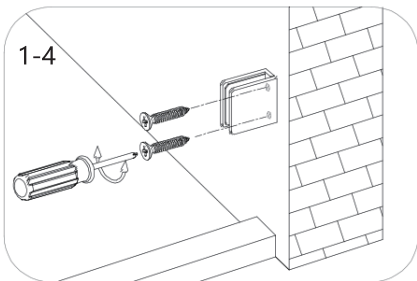
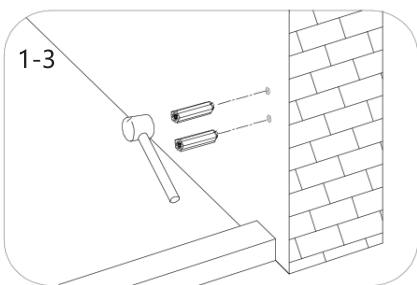
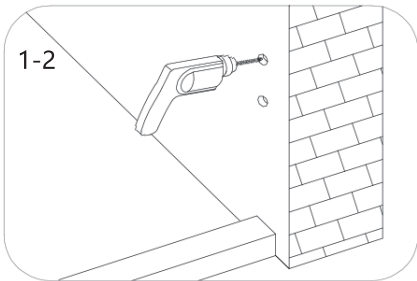
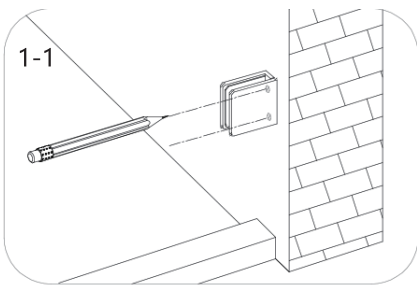

Step 1: Positioning and Installing the Wall Fixed Clip

- 1-1. Start by positioning the fixed clip against the wall, aligning the floor/base surface at a distance of 9.84" above the center (based on the glass opening), and mark it with a marker pen.
- 1-2. Use a 5/16" drill bit to create holes for marking points, with a diameter of 5/16".
- 1-3. Insert the wall plug into the drilled holes, ensuring that the plug's end is flush with the wall surface. Secure the wall fixed clip using screws. (Ensure they are tightened securely to maintain stability.)

Installation Steps

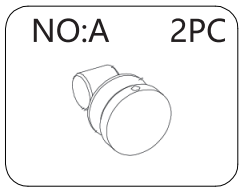

Glass Fixing Components

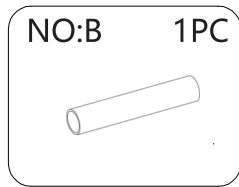

Circular Tube Guide Rail

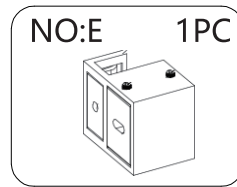

Left Wall Cover

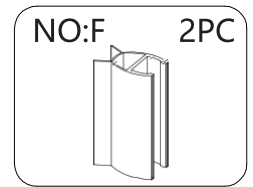

H-Shaped Strip

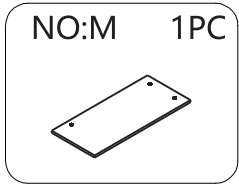

Fixed Glass

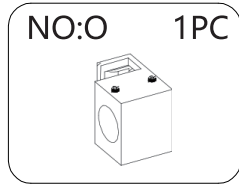

Right Wall Cover

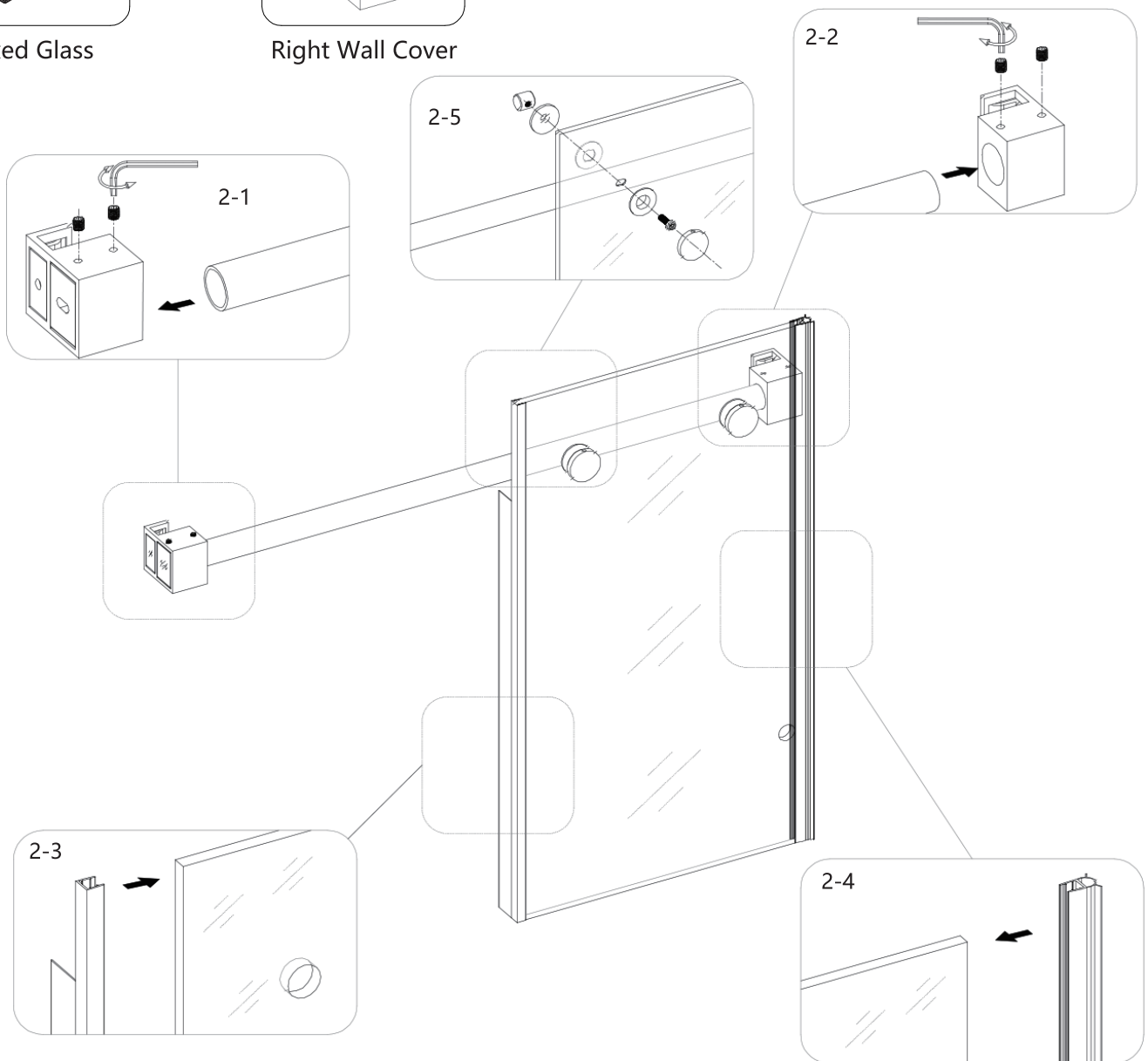

Step 2: Installation Sequence of Fixed Glass Accessories (for Product Positioning in the Next Step)

Drawings may not exactly define contour of the product.

Special Reminder

Before proceeding to the next step of installation, you need to know the distance of these components from the floor.

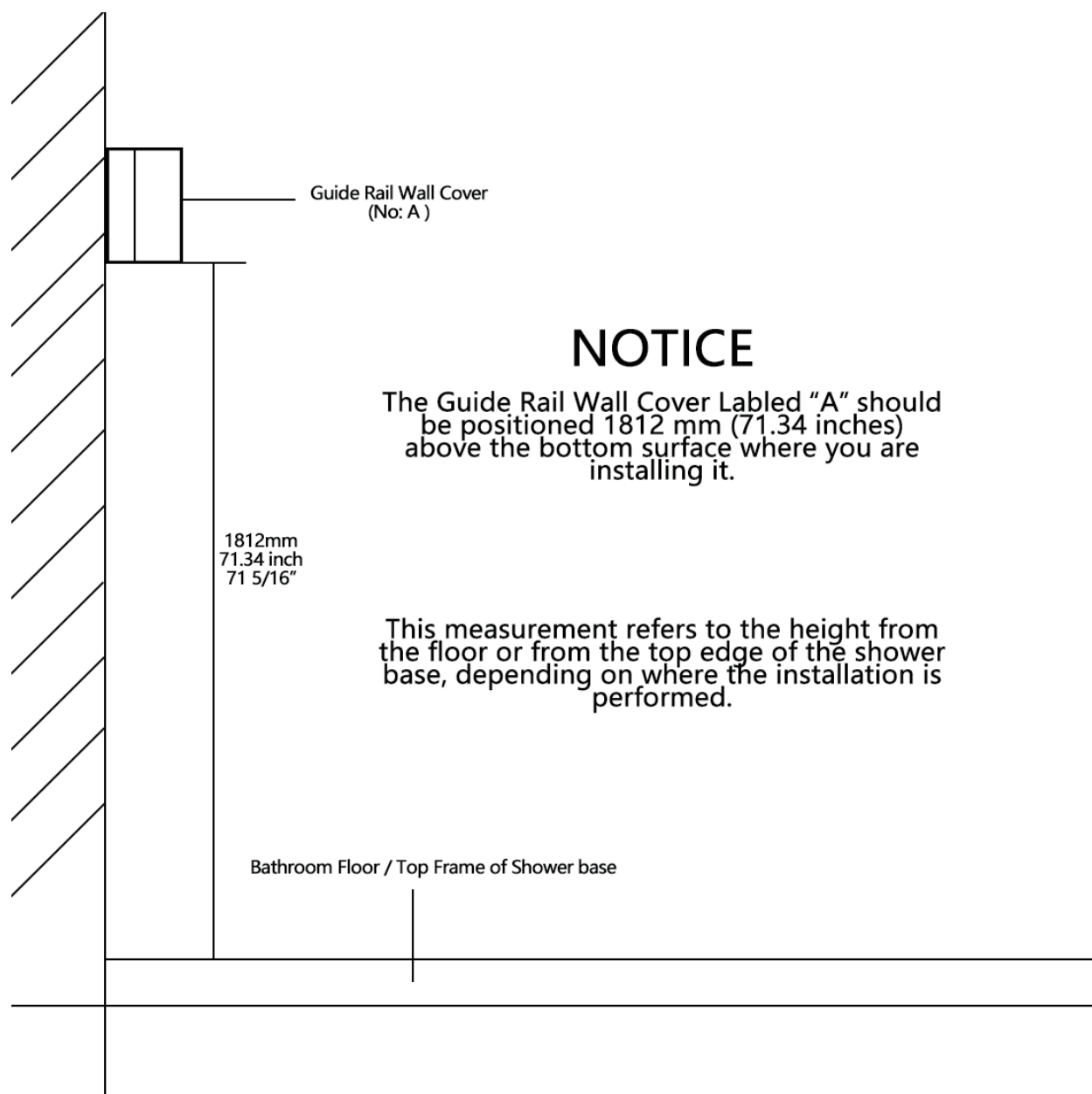

Installation Steps

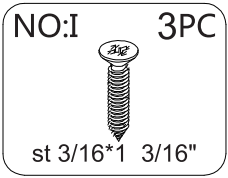

Screw-A

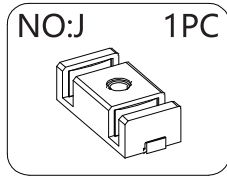

Lower Slider

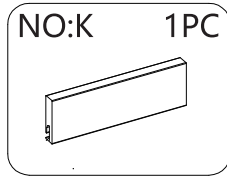

Lower Water Stop Bar

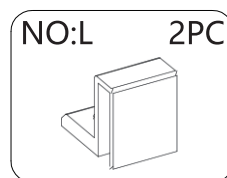

Water Stop Bar Fixing Parts

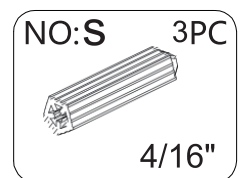

Wall Entry Plug

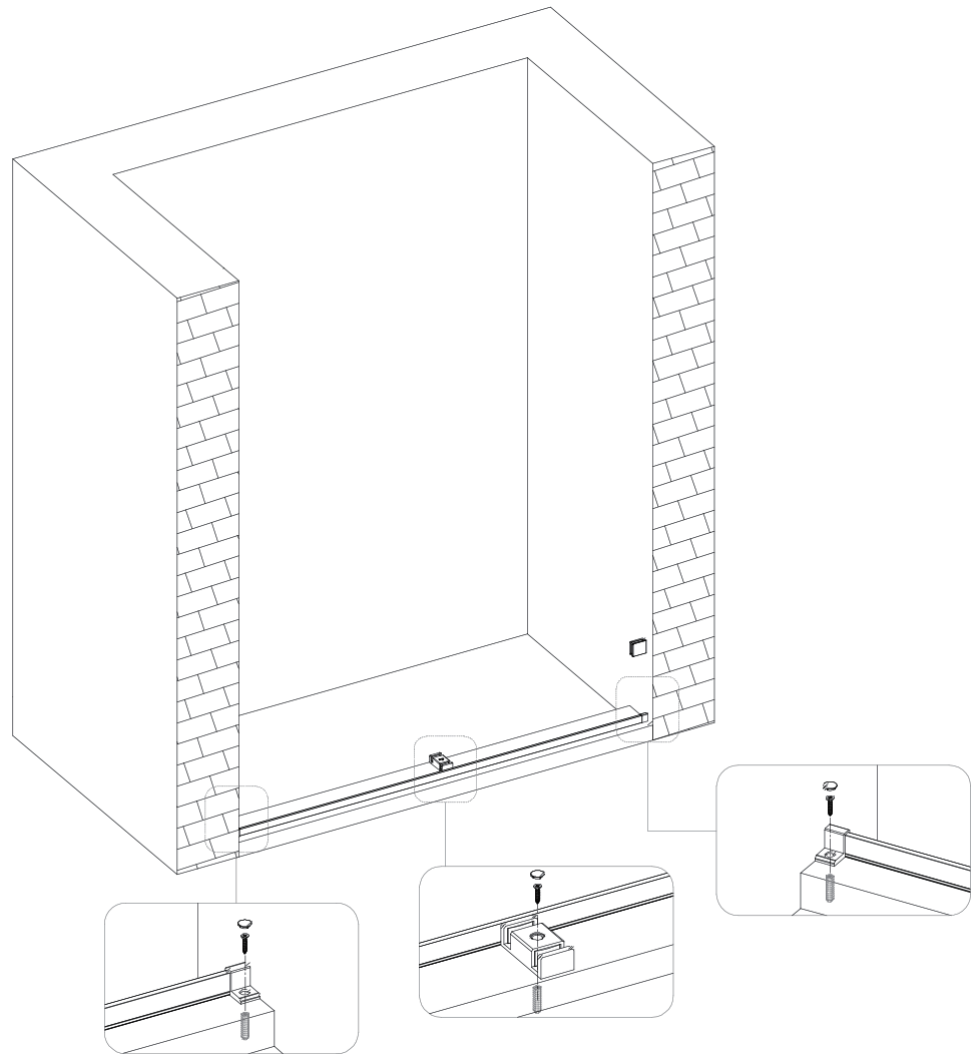
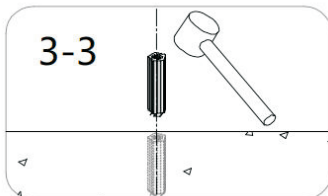
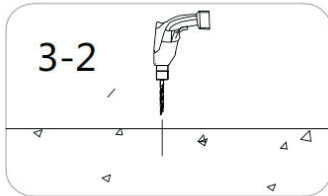
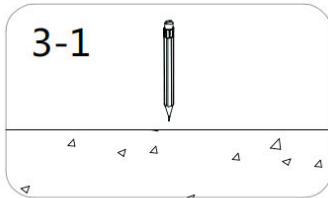

Step 3: Installation of the Lower Water Stop Bar

- 3-1. Begin by placing the lower water stop bar on the floor/base surface. Install each fixing part separately at both ends, and mark the positions using a marker pen.
- 3-2. Use a 5/16" drill bit to create holes for the marked points, with a diameter of 5/16".
- 3-3. Insert wall plugs into the holes, then secure the lower water stop bar with screws and cover them with decorative caps.

Drawings may not exactly define contour of the product.

Installation Steps

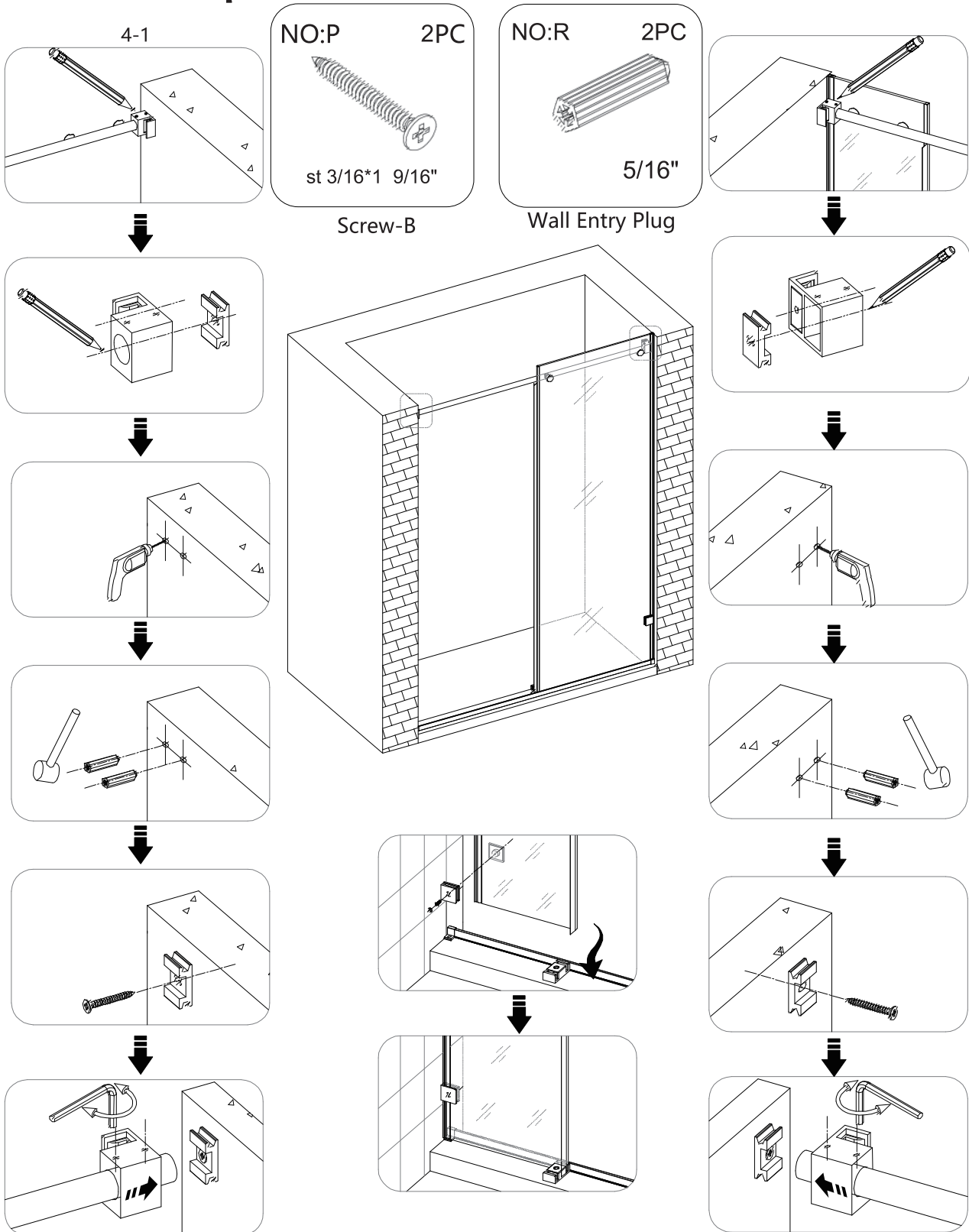

Drawings may not exactly define contour of the product.

Installation Steps

NO:C 2PC

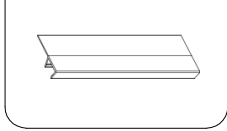

Water Blocking Strip

NO:D 4PC

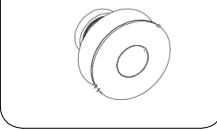

Pulley

NO:F 2PC

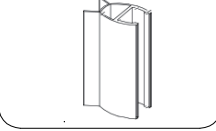

H-Shaped Strip

NO:G 1PC

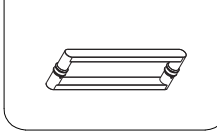

Handle

NO:H 1PC

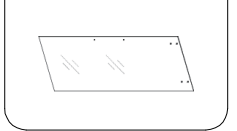

Door Glass

Step 5: Assembly of Door Glass Accessories

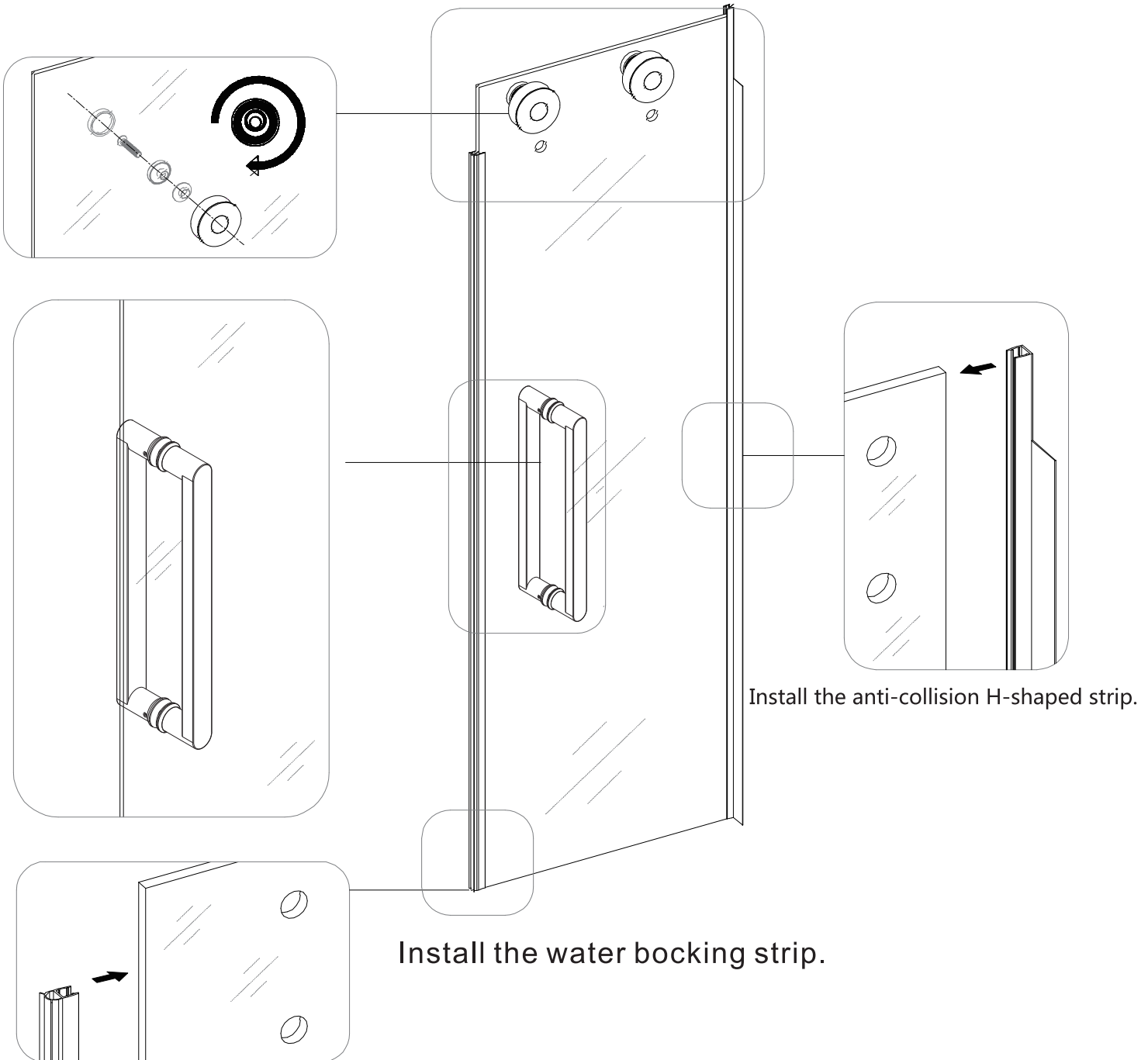

Drawings may not exactly define contour of the product.

Installation Steps

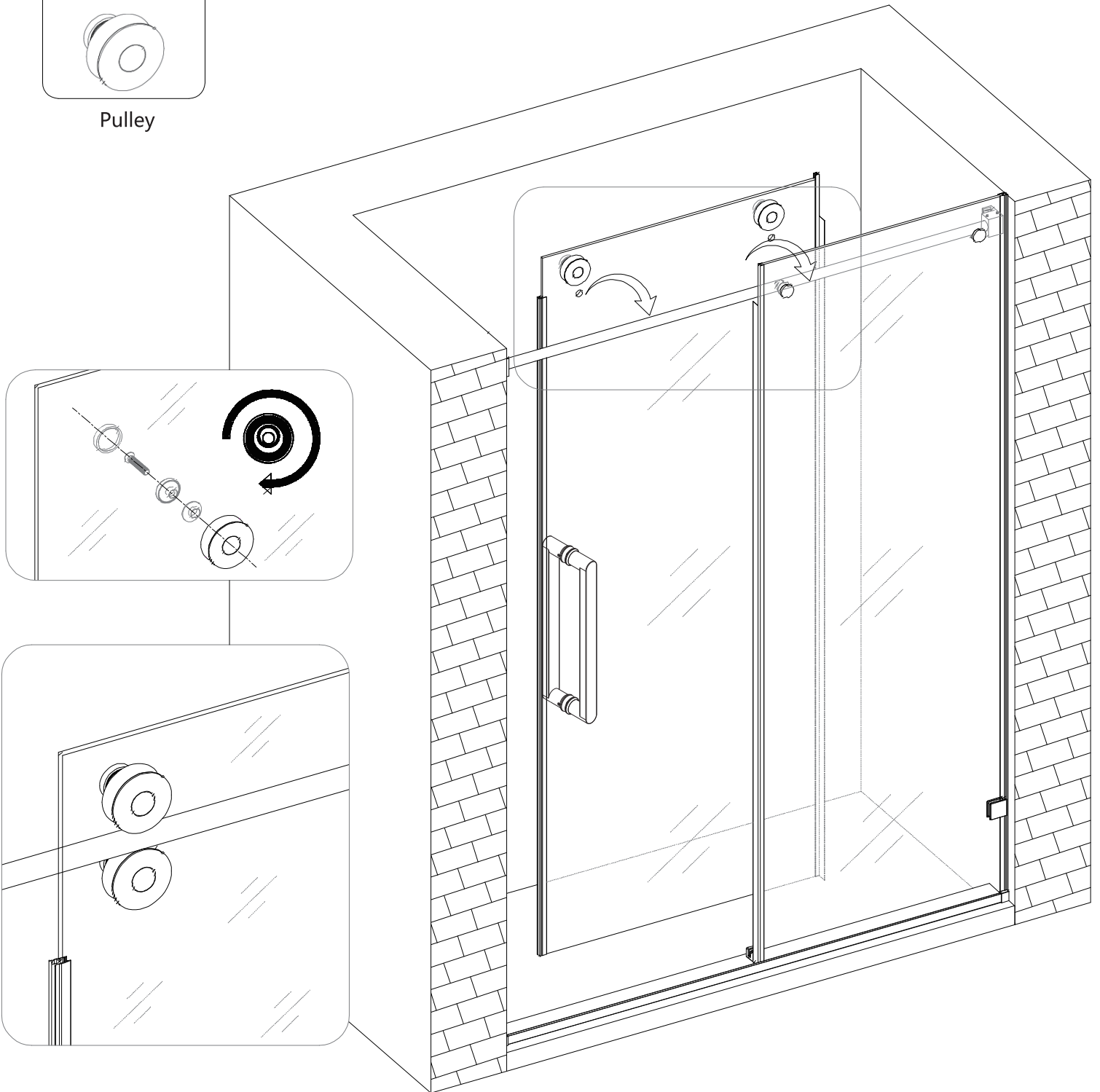
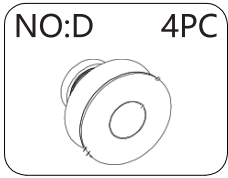

Step 6: Hanging Door Glass and Installing Anti-Detachment pulley (Second Set of Pulleys)

Drawings may not exactly define contour of the product.

Installation Steps

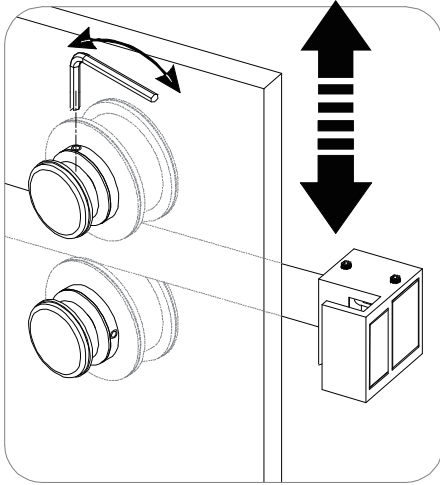

Debugging Guidelines for Door Glass

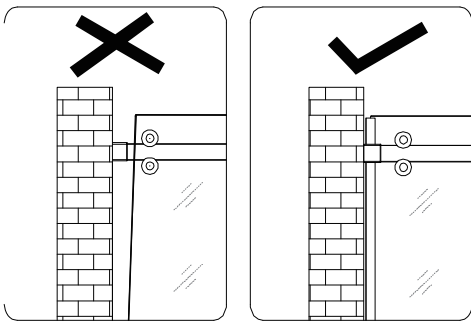

The door glass is considered qualified when it is in a vertical state without shaking.

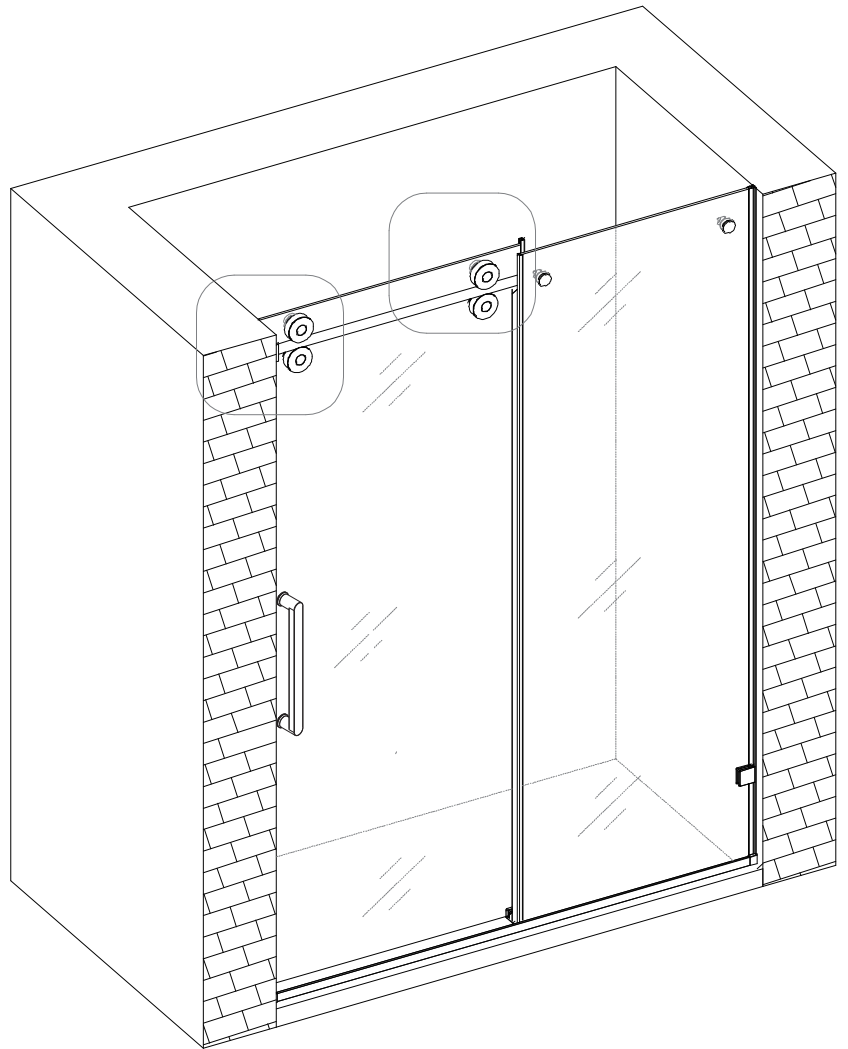

Step 7: Debugging the Door Glass

- 7-1: Use a hexagonal wrench to rotate the eccentric circular disc of the pulley. Adjust the upper and lower pulleys to the appropriate balance point (vertical state) and ensure that they are positioned inside the circular tube guide rail. This is primarily to prevent improper use and to serve as a means of preventing detachment.

Drawings may not exactly define contour of the product.

Installation Steps

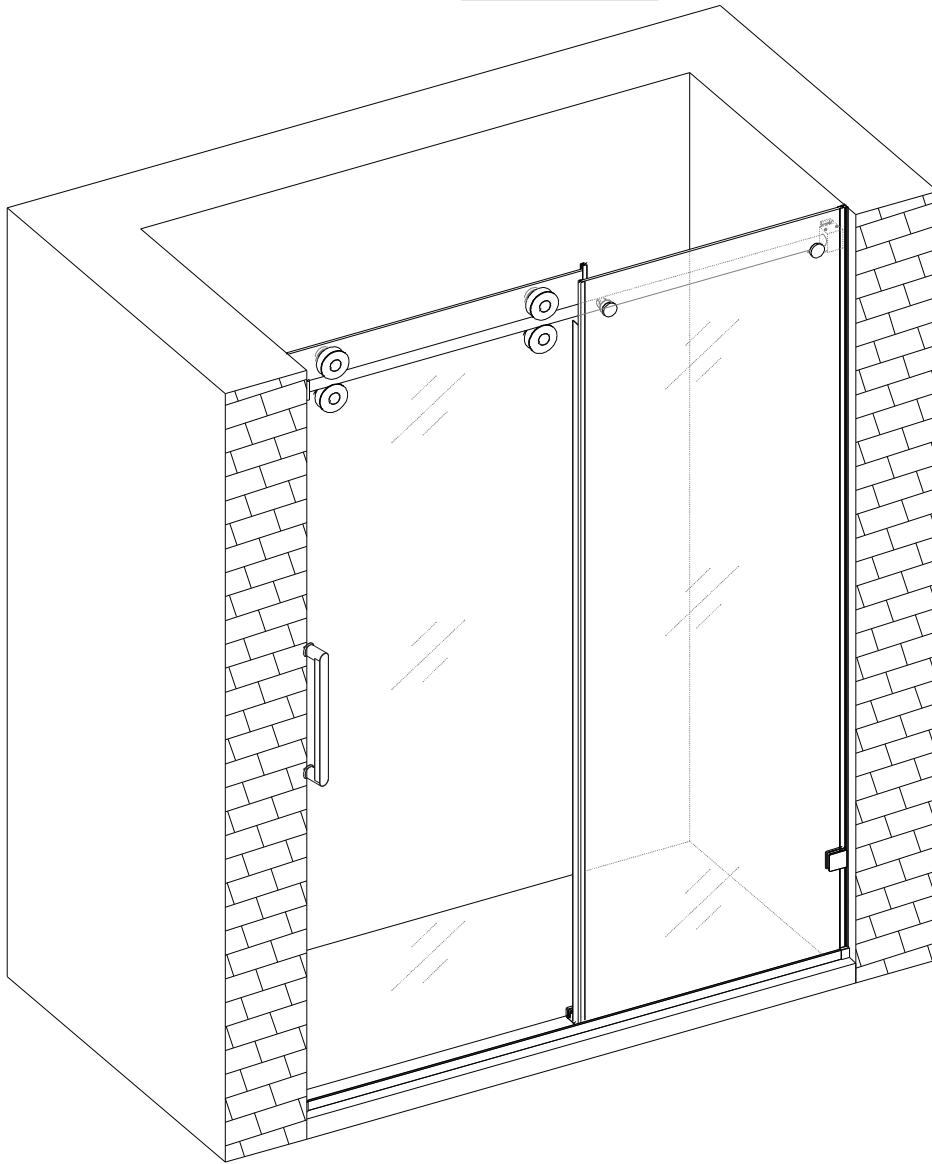
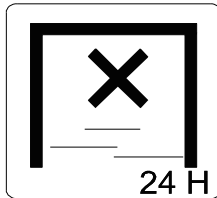
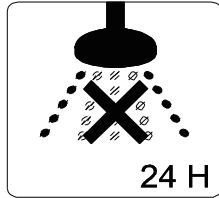
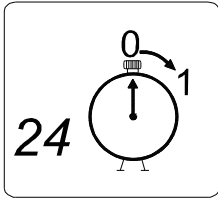

After installation, confirm that there are no abnormalities, and apply glass glue for waterproofing.

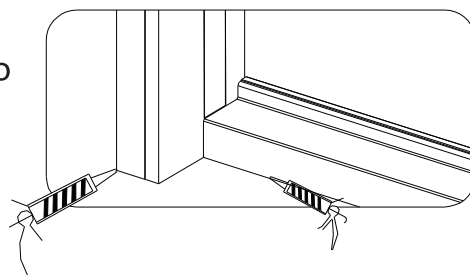

Drawings may not exactly define contour of the product.

LIMITED WARRANTY COVERAGE

5 YEAR LIMITED WARRANTY

DeerValley products are made with quality materials and excellent craftsmanship to provide customers with a long-lasting product. In the case of any defects in materials or craftsmanship under regular use, inspected within the first five years of delivery, DeerValley will provide replacement parts at no charge, or at its option, replace any product or part of the product that is deemed defective, under normal installation, use, service, and maintenance. This warranty applies only to the original purchaser. Proof of purchase will be required in the case of a claim. **SCRATCHES ARE NOT COVERED UNDER WARRANTY.**

The manufacturer warrants that this product will be free from manufacturing defects for the duration of the above-mentioned warranty period. Please retain a copy of the original invoice as proof of purchase.

DeerValley will, at its option, (1) repair or replace the defective part(s) or product(s) at no charge; (2) issue a refund for the original purchase price of the product(s) (valid within 30 days from the date of delivery); or (3) issue a credit to be applied toward the purchase of a new DeerValley product. Shipping/delivery charges may apply and are at DeerValley's sole discretion.

DeerValley recommends that installations be performed by a licensed, professional plumber. DeerValley will not be held responsible for any damage or product failure resulting from improper installation, misuse, or failure to hire a licensed professional. Additionally, DeerValley is not responsible for any removal or installation costs.

This limited warranty does not cover goods that have been subjected to accidents, negligence, improper installation, product abuse, product misuse, or the use of cleaners containing abrasives, alcohol, or other organic solvents. Such exclusions apply regardless of whether the actions were performed by a contractor, service company, or the purchaser.

DeerValley's responsibility under this limited warranty is limited solely to the replacement of parts and does not cover any other costs. DeerValley will not be responsible for labor charges or any damage incurred during installation, repair, or replacement, nor for any indirect, incidental, or consequential damages, losses, injuries, or costs of any kind related to this product. Except as required by law, this limited warranty replaces and excludes all other warranties, conditions, and guarantees, whether expressed or implied, statutory or otherwise, including but not limited to those regarding merchantability or fitness for a particular purpose.

RESPONSIBILITIES OF OTHERS

It is the responsibility of the installer or building contractor, acting on behalf of the user, to inspect the unit prior to installation. They are responsible for ensuring that the unit is free from defects or damage.

Notices are placed on and within the unit, as well as on the shipping carton, to inform the installer of their responsibility.

If a problem is identified, the unit must not be installed. DeerValley is not responsible for failures or damage that could have been identified, repaired, or prevented through proper inspection and testing prior to installation.

Damage occurring during transit is the responsibility of the carrier. The user or installer must open the crate and inspect the unit for damage upon delivery. If damage is discovered, it must be reported immediately to the seller and the carrier in writing, and an inspection must be requested. If the carrier fails to respond, the issue should be reported to both the seller and the carrier. Freight claims should be filed promptly thereafter.

LIMITATIONS AND EXCLUSIONS

This warranty does not cover negligence, misuse, abuse, improper installation, carelessness, accidents, hard water or mineral deposits, exposure to corrosive materials, misapplication, damages resulting from improper maintenance, alteration of the product, or failure to follow the care or installation instructions provided with your product. The warranty becomes void if the DeerValley product is altered or if repairs are attempted using unauthorized accessories or parts not provided by DeerValley.

DeerValley is not liable for the loss of use of its products, inconvenience, or any other incidental or consequential costs, expenses, or damages. Please note that some states do not allow the exclusion or limitation of incidental damages.

DISCLAIMER

Except as expressly stated, no warranties or obligations, whether express, implied, oral, or statutory, are provided. No dealer or other individual has the authority to make any warranties or representations regarding DeerValley or its products. DeerValley shall not be held responsible for any such unauthorized warranties or representations.

WARRANTY SERVICE

NOTE: When requesting warranty service, please ensure you have the following:

- A copy of the original invoice
- Date of installation
- Description and pictures of the defect
- Model number or product description

To obtain warranty service or replacement parts, contact DeerValley Customer Service. DeerValley will determine whether to repair or replace the product, issue a refund, or provide a credit.