

STYLE 'XT'

U.S. PAT. 5,316,039

THE CHICAGO FAUCET CO.

* JIFFY KIT 1277NF FOR QUATURN
AND SLO-COMPRESSION UNITS CONTAINS PARTS
MARKED WITH ASTERISK.

**** CAUTION - CLOSE UNIT BEFORE INSTALLING IN FAUCET BODY.**

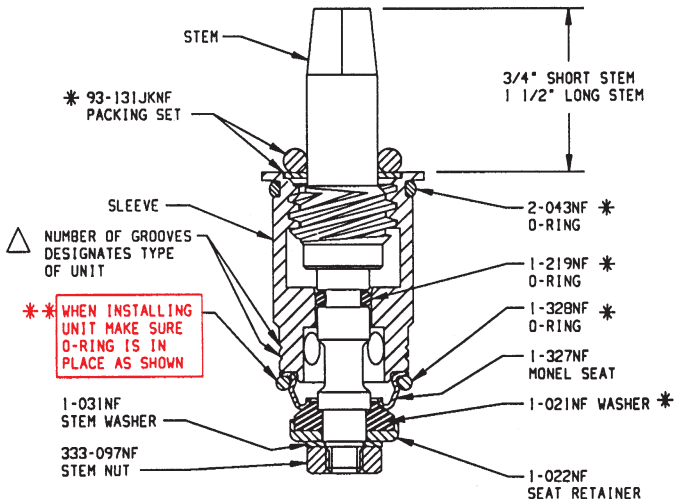

-- BEFORE INSTALLING A NEW CARTRIDGE FLUSH LINES COMPLETELY.

-- ALWAYS HAVE A NEW CARTRIDGE IN THE CLOSED POSITION WHEN
INSTALLING INTO VALVE.

-- TO INSTALL RIGHT HAND CARTRIDGE, PUSH CARTRIDGE INTO BODY UNTIL IT
SEATS. ADD CAP NUT AND TIGHTEN HAND TIGHT. ADD HANDLE AND ROTATE TO
CLOSED POSITION. FULLY TIGHTEN CAP NUT TO 25 FT. LBS. TORQUE.

-- TO INSTALL LEFT HAND CARTRIDGE, PUSH CARTRIDGE INTO BODY UNTIL IT SEATS.
ADD CAP NUT AND TIGHTEN HAND TIGHT. ADD HANDLE AND ROTATE TO OPEN POSITION.
FULLY TIGHTEN CAP NUT TO 25 FT. LBS. TORQUE. RETURN HANDLE TO OFF POSITION.

-- CLEAN FAUCET FINISH WITH SOAP AND WATER ONLY.



GROOVE INDEX

- 1 • RIGHT HAND QUATURN CARTRIDGE
- 2 • LEFT HAND QUATURN CARTRIDGE
- 3 • RIGHT HAND SLO-COMPRESSION CARTRIDGE
- 4 • LEFT HAND SLO-COMPRESSION CARTRIDGE

STYLE 'X'

THE CHICAGO FAUCET CO.

* JIFFY KIT 1277NF FOR QUATURN
AND SLO-COMPRESSION UNITS CONTAINS PARTS
MARKED WITH ASTERISK.

**** CAUTION - CLOSE UNIT BEFORE INSTALLING IN FAUCET BODY.**

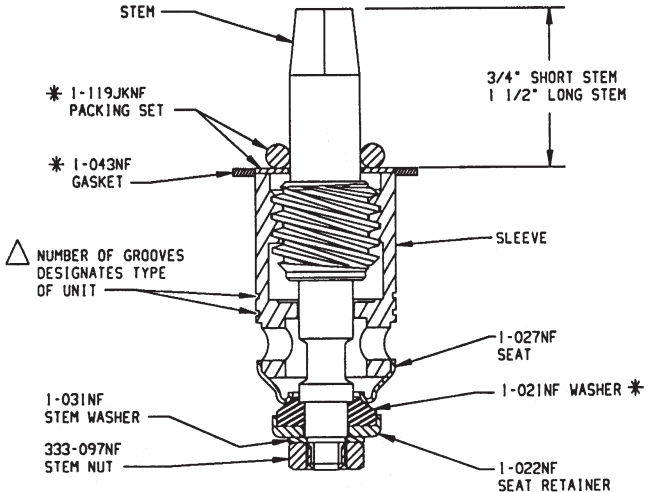

- BEFORE INSTALLING A NEW CARTRIDGE FLUSH LINES COMPLETELY.
- TO LOCK RIGHT HAND CARTRIDGE IN PLACE, INSTALL HANDLE AND CAP NUT. ROTATE HANDLE TO FULL OFF (CLOSED) POSITION AND SECURELY TIGHTEN CAP NUT.
- TO LOCK LEFT HAND CARTRIDGE IN PLACE, INSTALL HANDLE AND CAP NUT. ROTATE HANDLE TO FULL ON (OPEN) POSITION AND SECURELY TIGHTEN CAP NUT. RETURN HANDLE TO OFF POSITION.
- CAP NUT MUST BE TIGHTENED TO 30 FT. LBS. MINIMUM SO THAT CARTRIDGE WILL NOT CONTINUE TO TURN IN OPEN POSITION.
- CLEAN UP FAUCET FINISH WITH SOAP AND WATER ONLY.

△ GROOVE INDEX

- 1 • RIGHT HAND QUATURN CARTRIDGE
- 2 • LEFT HAND QUATURN CARTRIDGE
- 3 • RIGHT HAND SLO-COMPRESSION CARTRIDGE
- 4 • LEFT HAND SLO-COMPRESSION CARTRIDGE