

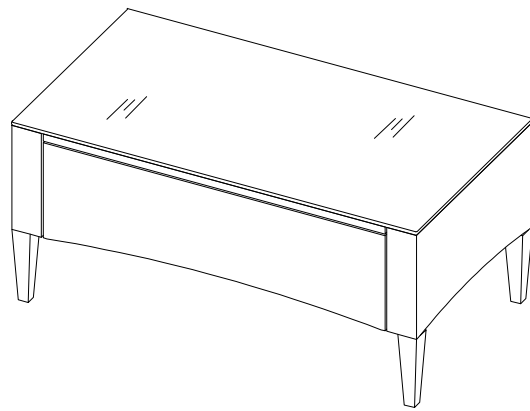

Outdoor Wicker Coffee Table

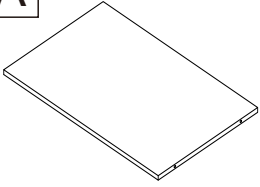
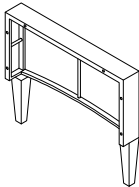
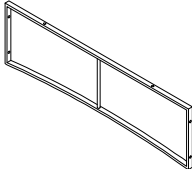
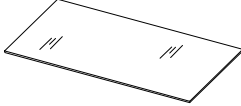

PART LIST

<p>A</p> 	<p>B</p> 	<p>C</p> 	<p>D</p> 
<p>Top Panel 1 PC</p>	<p>Side Panel 2 PCS</p>	<p>End Panel 2 PCS</p>	<p>Glass Top 1 PC</p>

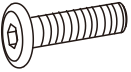

HARDWARE LIST

<p>#1</p>  <p>M6*30mm</p>	<p>#2</p>  <p>M6mm</p>	<p>#3</p>  <p>M6mm</p>
<p>Bolt 16 PCS (Extra1)</p>	<p>Flat Washer 16 PCS (Extra1)</p>	<p>Allen Wrench 1 PC</p>

Step 1. Lay top panel (part A) upside down on a soft flat surface, such as carpet, as shown below. Attach end panels (part C) to top panel (part A) using bolts (part #1), flat washers (part #2) and allen wrench (part #3).

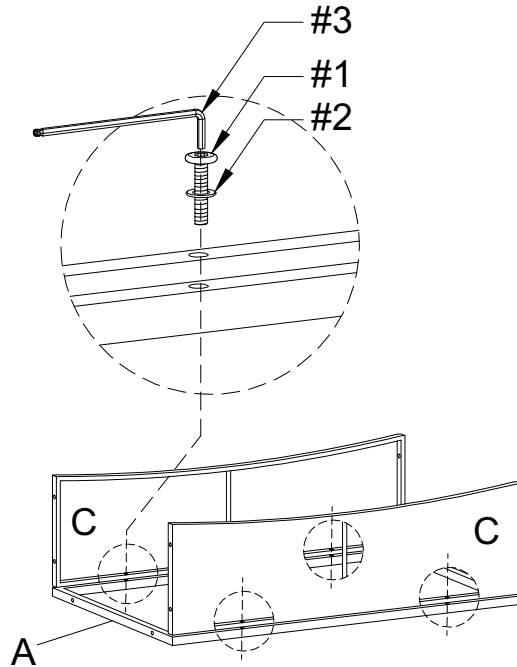
NOTE: Please do not fully tighten bolts until unit is fully assembled.





- | | | |
|----|---------------------------------------------------------------------------------------|----|
| #1 |  | x4 |
| #2 |  | x4 |
| #3 |  | x1 |

Step 2. Attach side panels (part B) to end panels (part C) and top panel (part A) using bolts (part #1), flat washers (part #2) and allen wrench (part #3).

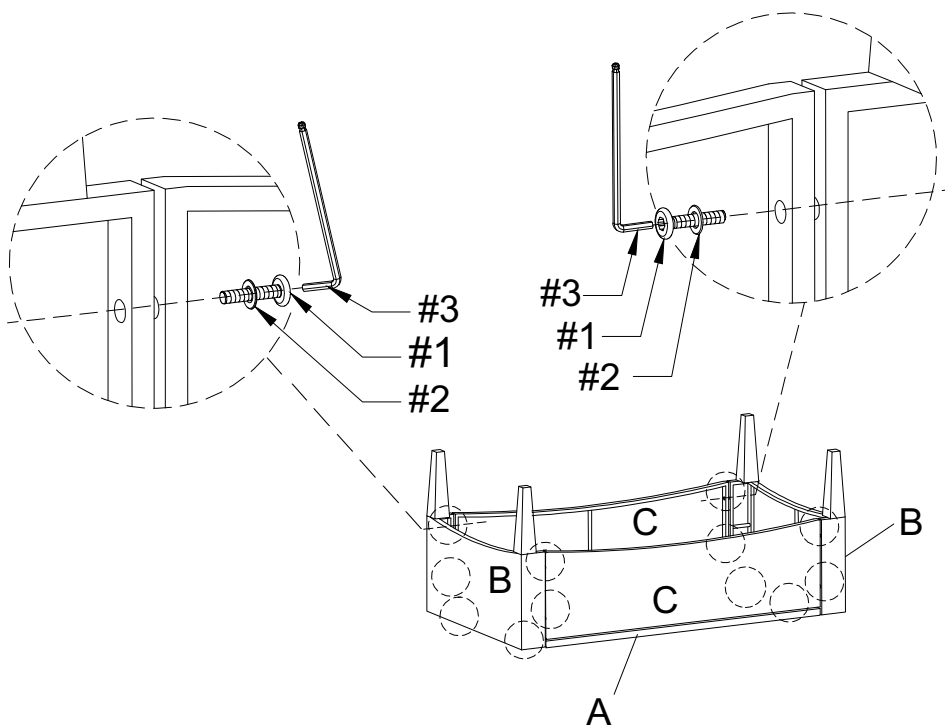
NOTE: Please fully tighten all bolts at this time.



- | | | |
|----|---------------------------------------------------------------------------------------|-----|
| #1 |  | x12 |
| #2 |  | x12 |
| #3 |  | x1 |

Step 3. Carefully turn unit upright. Gently place glass top (part D) on assembled unit.

