



WARNING!

Children have died from furniture tipover. Fixed wall device have been included with this product;you must install the fixed wall device according to these instructions in order to minimize the risk of furniture.If you have any questions about this product or the Fixed wall device , please contact us immediately.

Never allow children to climb or hang on furniture,including drawers or cabiner doors.

In addition to installing the restrains,to help prevent tip-over.







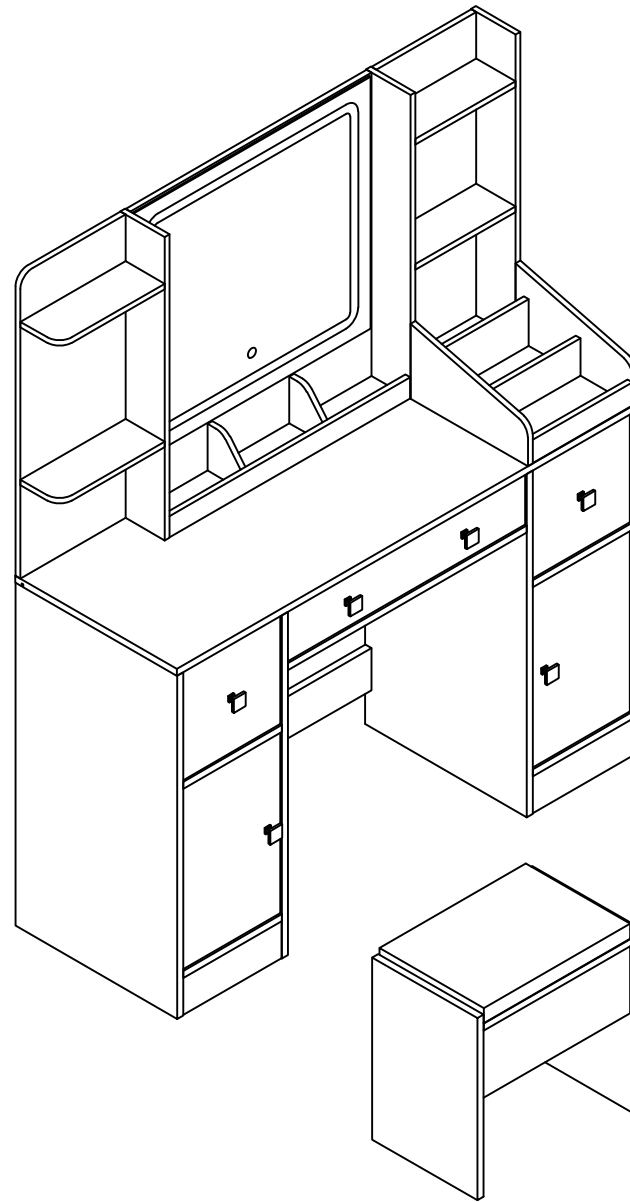

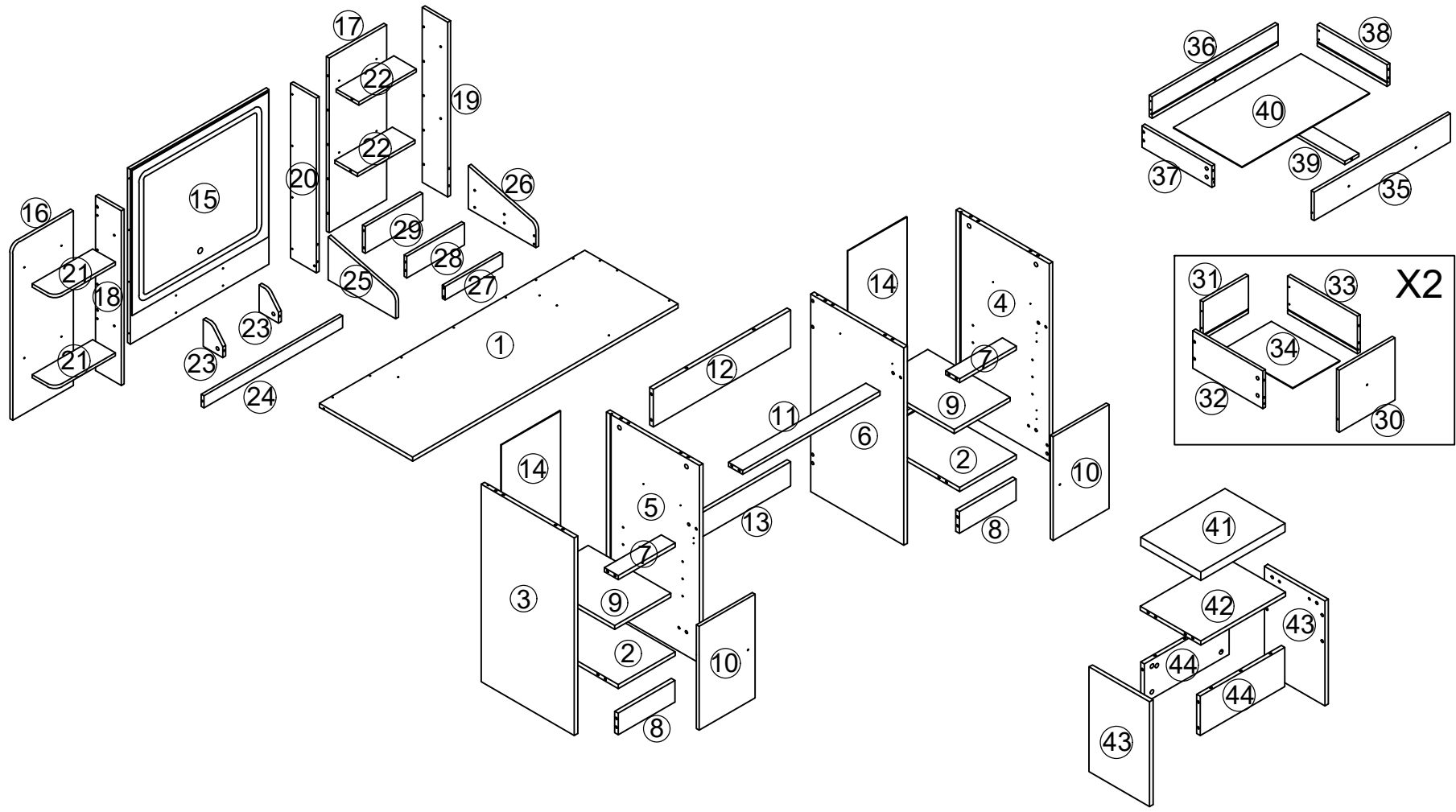

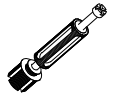

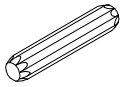
1. Never put a TV or other heavy objects on top of this product.
2. Do not stand on the product.

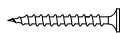
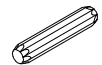
! WARNING	
	Children have died from furniture tipover. To reduce the risk of furniture tipover: <ul style="list-style-type: none">• ALWAYS install tipover restraint provided.• NEVER put a TV on this product.• NEVER allow children to stand, climb or hang on drawers, doors, or shelves.• NEVER open more than one drawer at a time.• Place heaviest items in the lowest drawers.• Do not defeat or remove the drawer interlock system. <p><i>This is a permanent label. Do not remove!</i></p>
	

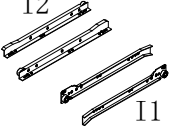
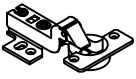
QL24004



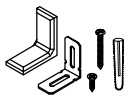

<p>A</p>  <p>52PCS</p>	<p>B</p>  <p>52PCS</p>	<p>C</p> <p>8*40</p>  <p>32PCS</p>	<p>D</p> <p>3.5*12</p>  <p>52PCS</p>	<p>E</p> <p>3.5*30</p>  <p>46PCS</p>	<p>F</p> <p>6*30</p>  <p>24PCS</p>	<p>G</p>  <p>31PCS</p>	<p>H</p>  <p>8PCS</p>	<p>I</p> <p>300mm</p>  <p>3PCS</p>	<p>J</p>  <p>4PCS</p>
<p>K</p>  <p>8PCS</p>	<p>L</p>  <p>6PCS</p>	<p>M</p> <p>4*18</p>  <p>6PCS</p>	<p>N</p>  <p>2PCS</p>	<p>O</p>  <p>8PCS</p>	<p>P</p>  <p>2PCS</p>				

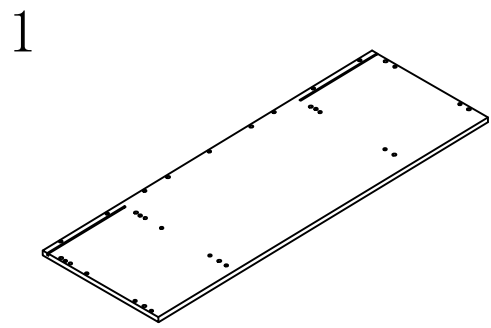

1140*400 1PS

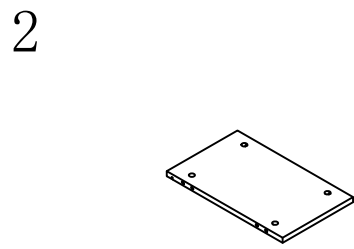

244*400 2PS

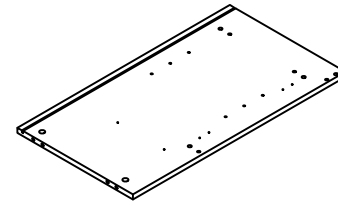

735*400 1PS

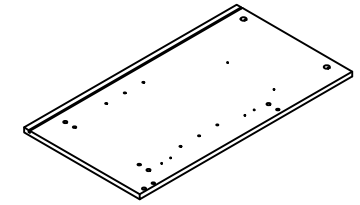

735*400 1PS

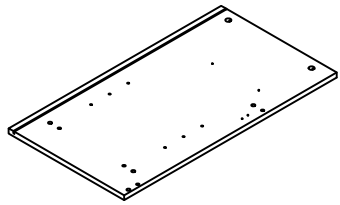

735*400 1PS

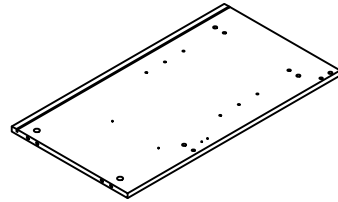

735*400 1PS



244*60 2PS

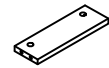

244*80 2PS

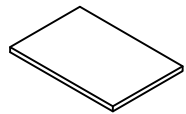

241*355 2PS

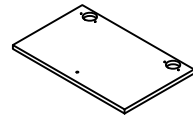

386*240 2PS

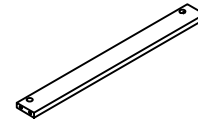

590*60 1PS

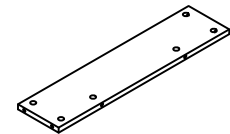

590*140 1PS

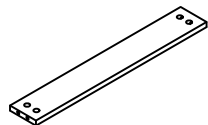

590*90 1PS

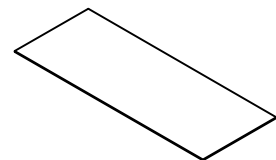

650*254 2PS

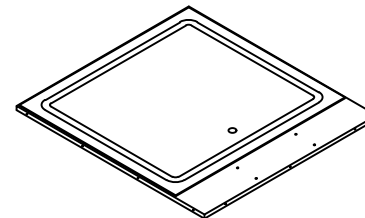

650*596 1PS

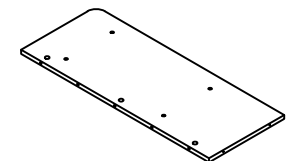

650*260 1PS

17

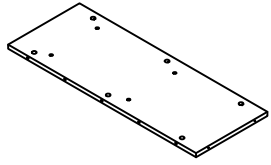

650*247 1PS

18

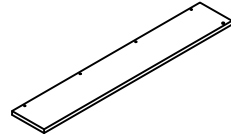

650*110 1PS

19

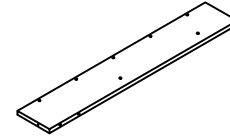

650*110 1PS

20

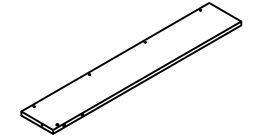

650*110 1PS

21



260*97 2PS

22

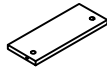

247*97 2PS

23



100*84 2PS

24

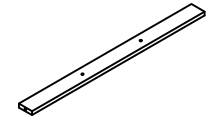

596*45 1PS

25

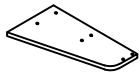

160*290 1PS

26

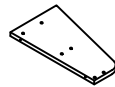

160*290 1PS

27



247*50 1PS

28

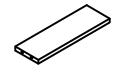

247*80 1PS

29



247*100 1PS

30

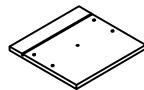

240*231 2PS

31



195*140 2PS

32

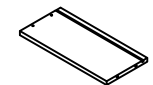

300*140 2PS

33

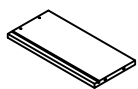

300*140 2PS

34

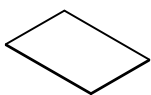

202*294 2PS

35

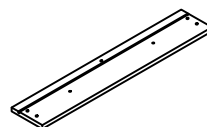

586*106 1PS

36

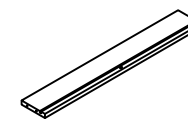

541*80 1PS

37



300*80 1PS

38

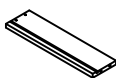

300*80 1PS

39

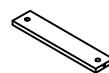

287*60 1PS

40

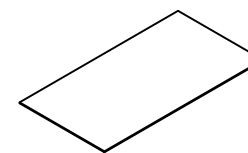

548*294 1PS

41

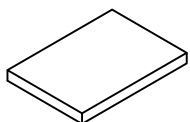

364*260 1PS

42

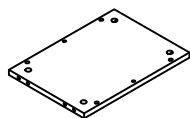

364*260 1PS

43

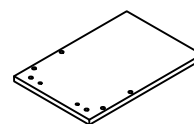

390*260 2PS

44

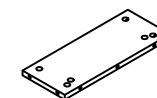

364*146 2PS



Hardware installation demonstration

NOTE: Please make sure "A" hardware tightened and can't be pulled out!

I

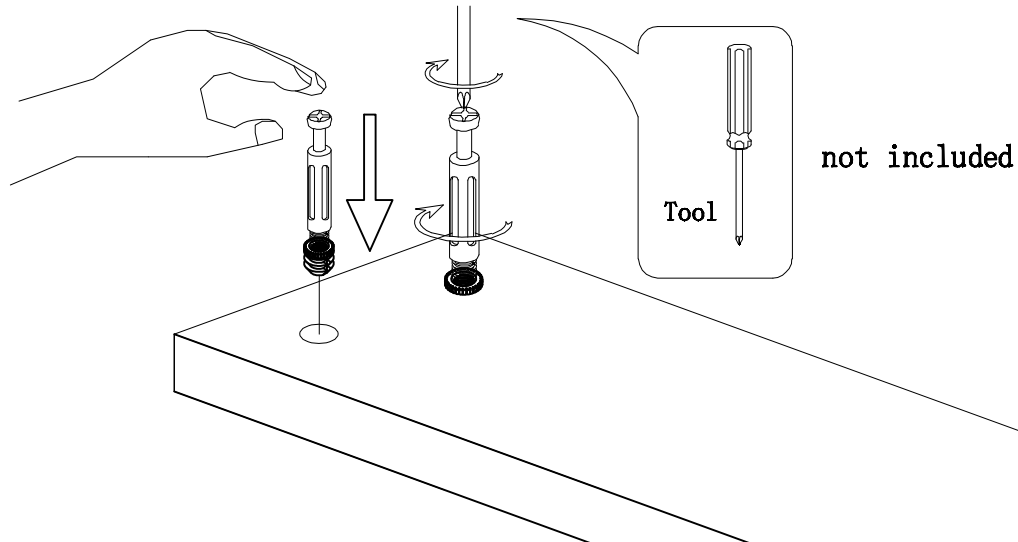

II

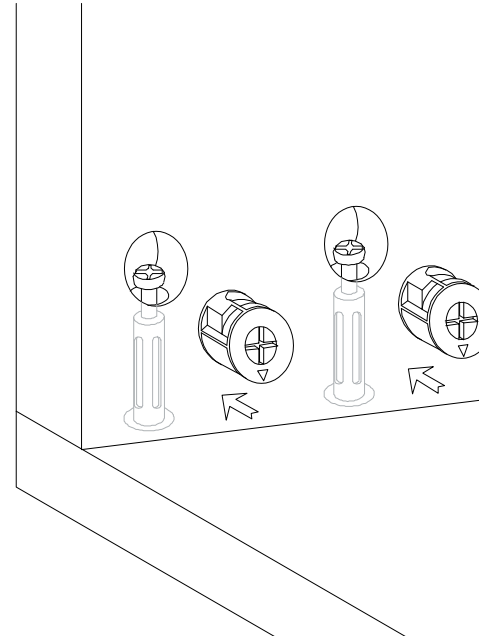

III

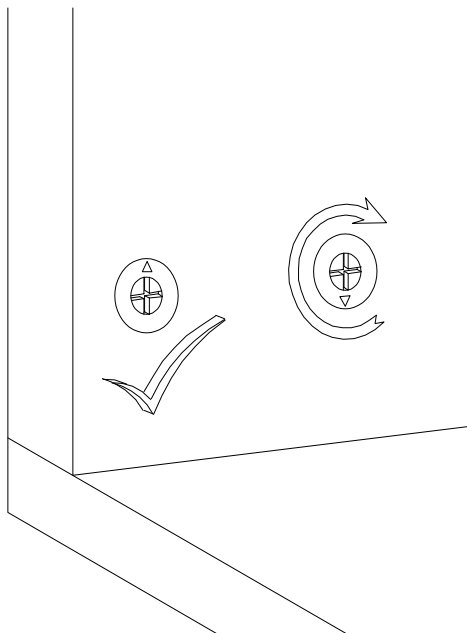





IV

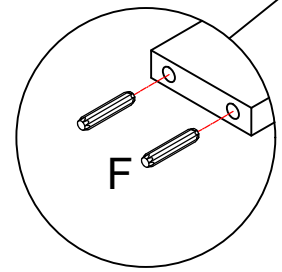
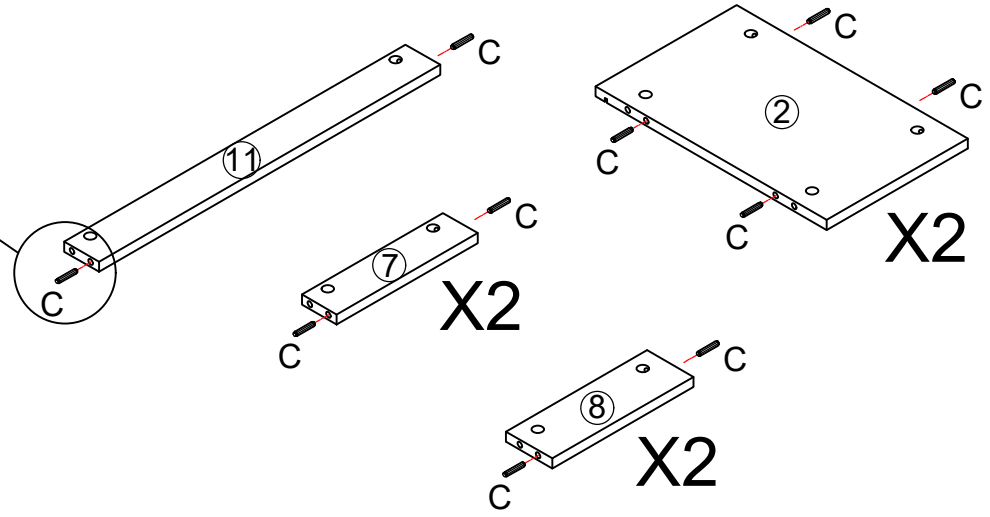
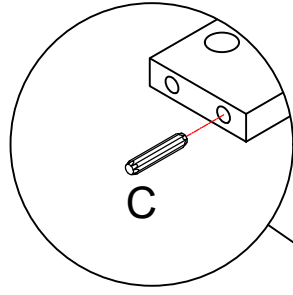
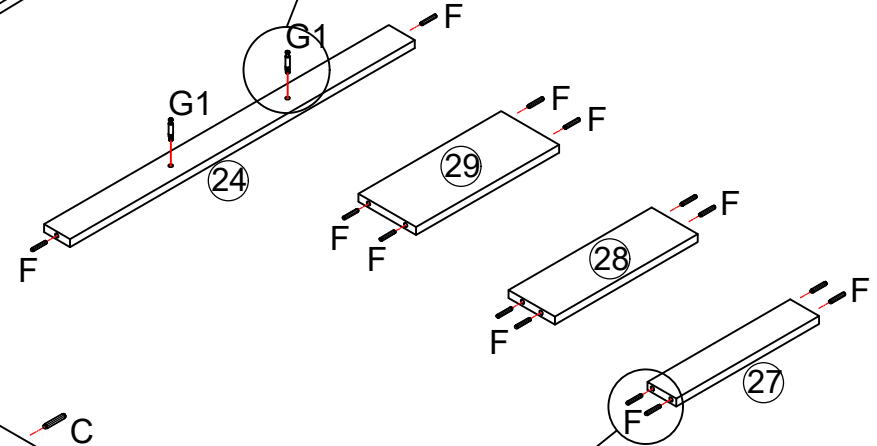
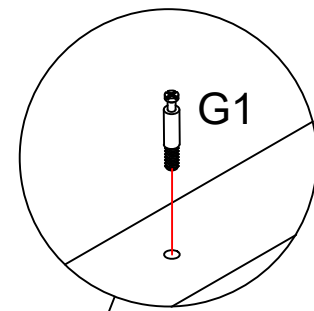
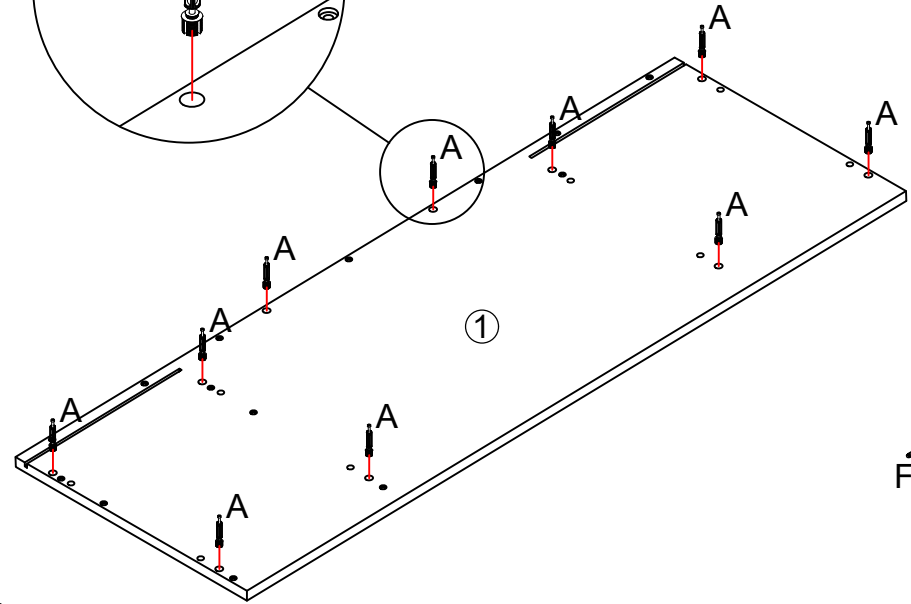
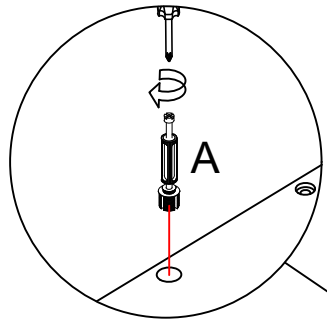

Scan QR code for assembly video

1





	A*10
	C*18
	F*14
	G1*2

put A on board ①
 put C on board ② ⑦ ⑧ ⑪
 put F on board ⑲ ⑳ ㉑
 put G1 on board ㉔

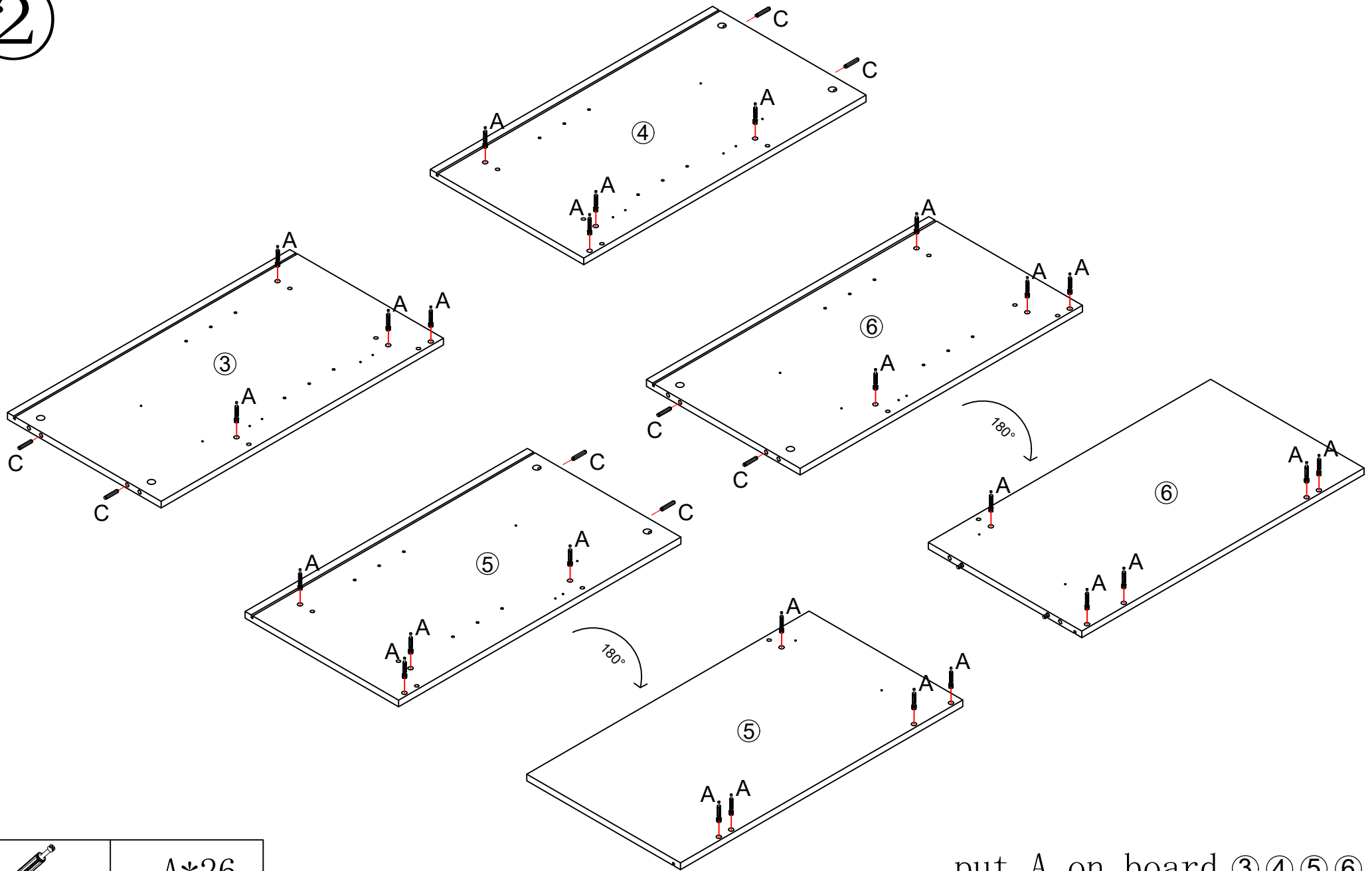
2



	A*26
	C*8

put A on board ③④⑤⑥
put C on board ③④⑤⑥

3

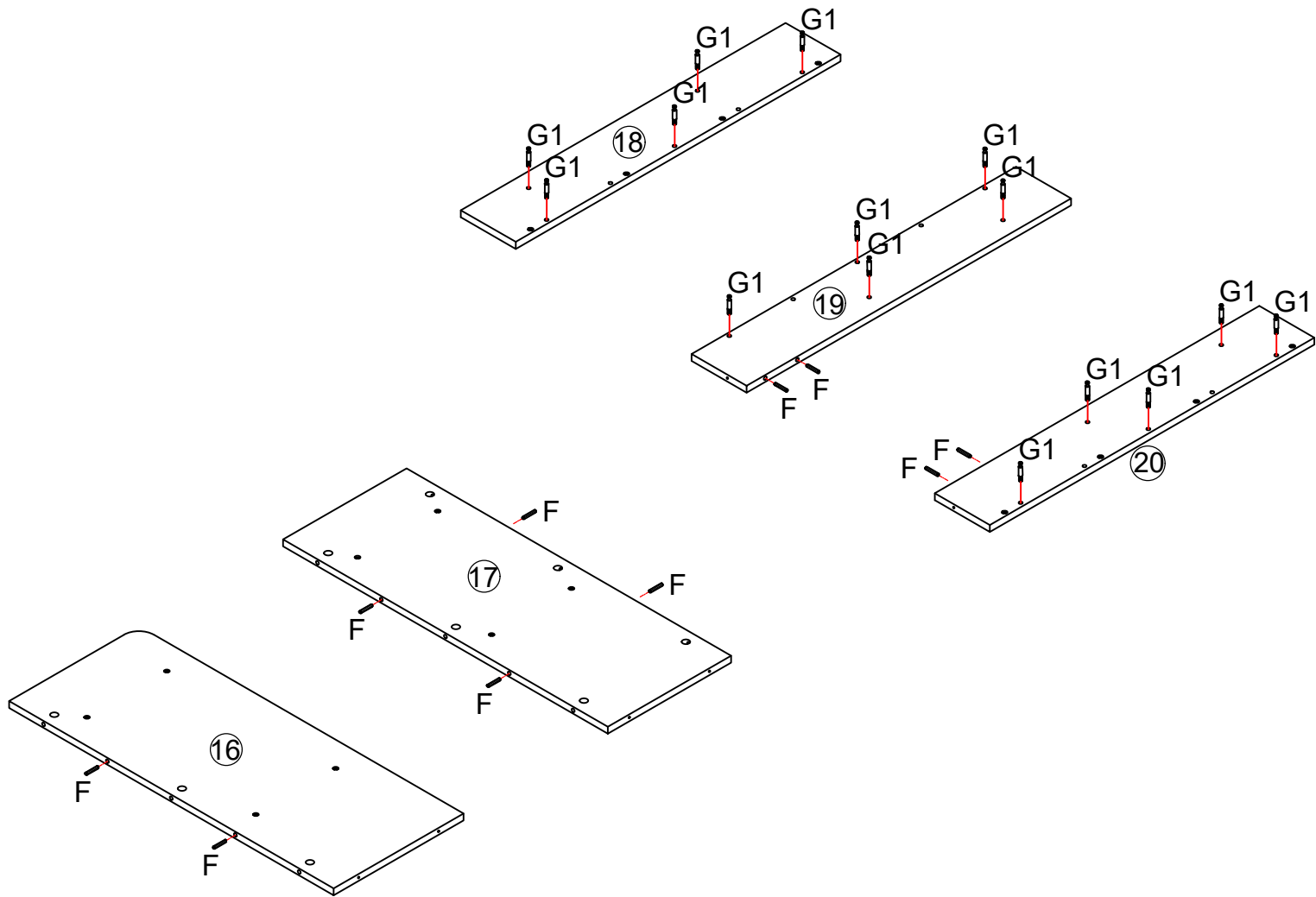

F*10



G1*15

put F on board 16 17 19 20
put G1 on board 18 19 20

4

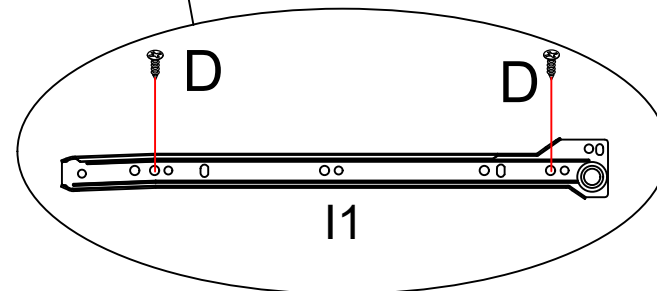
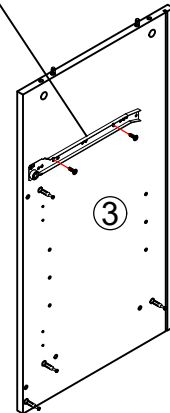
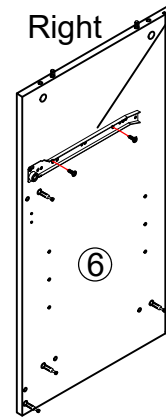
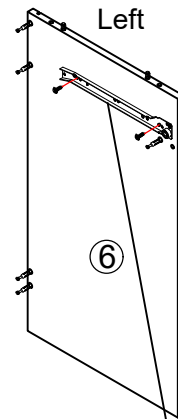
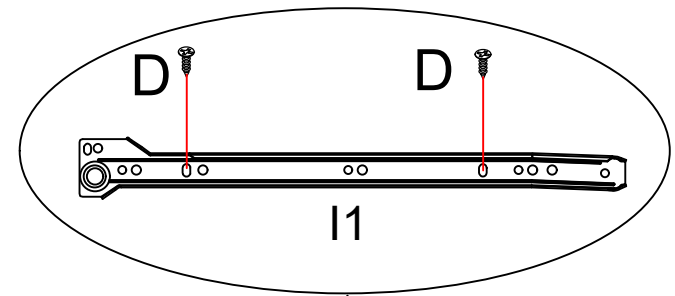
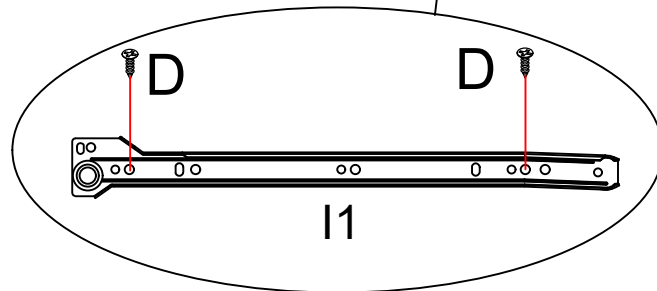
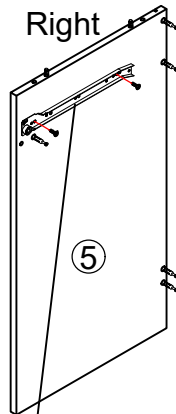
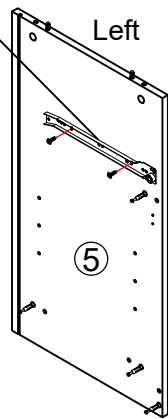
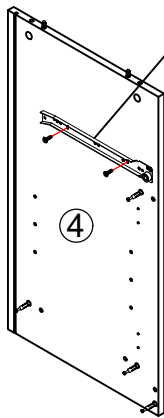
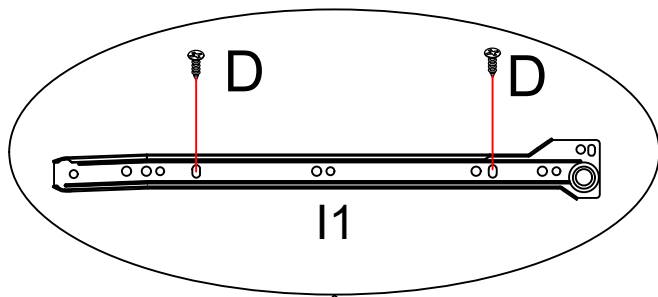

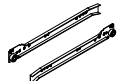
	D*12
	I1*3

5

Make sure the arrow on the screw align to the hole on the side.

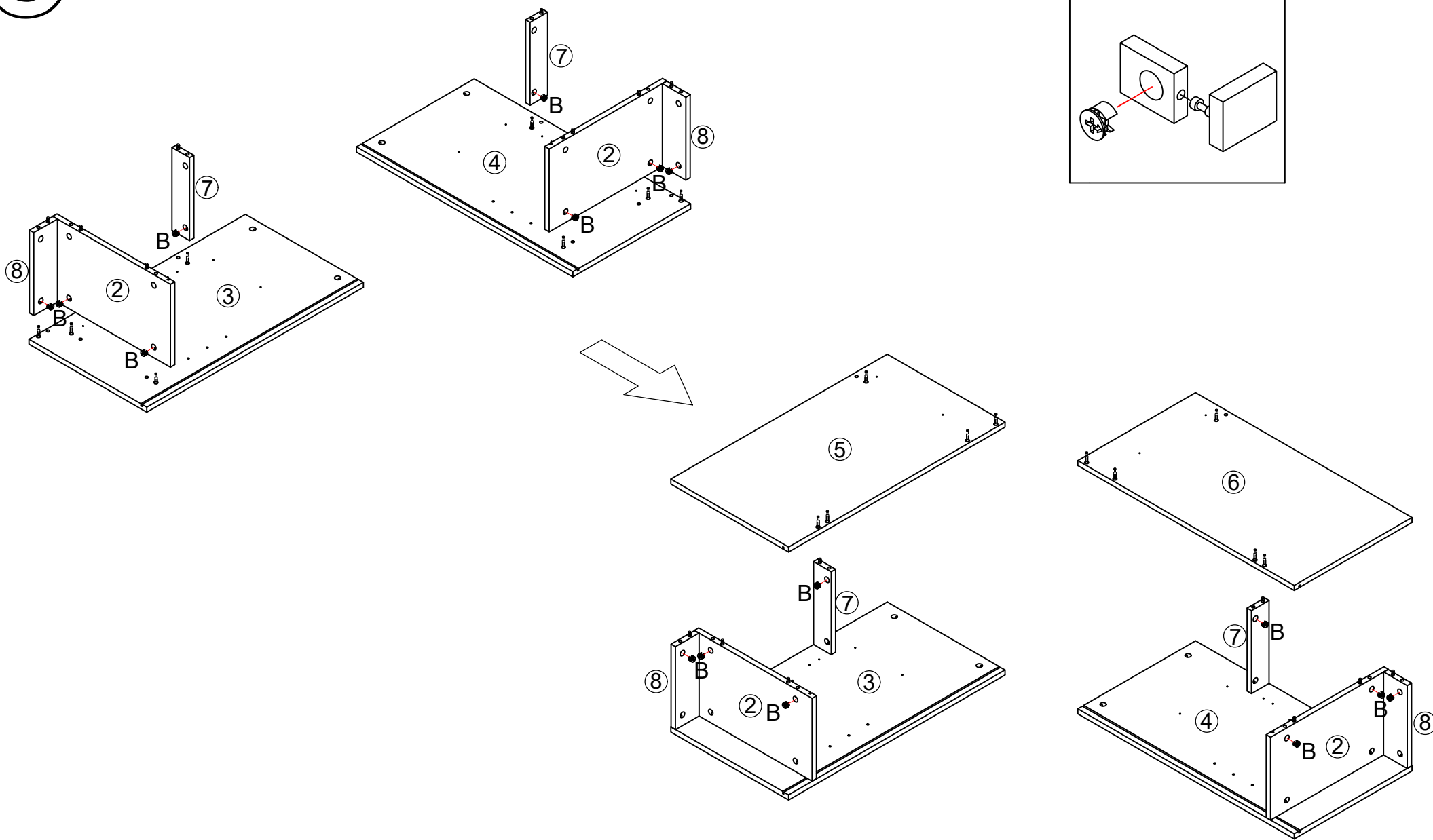

B*16

6

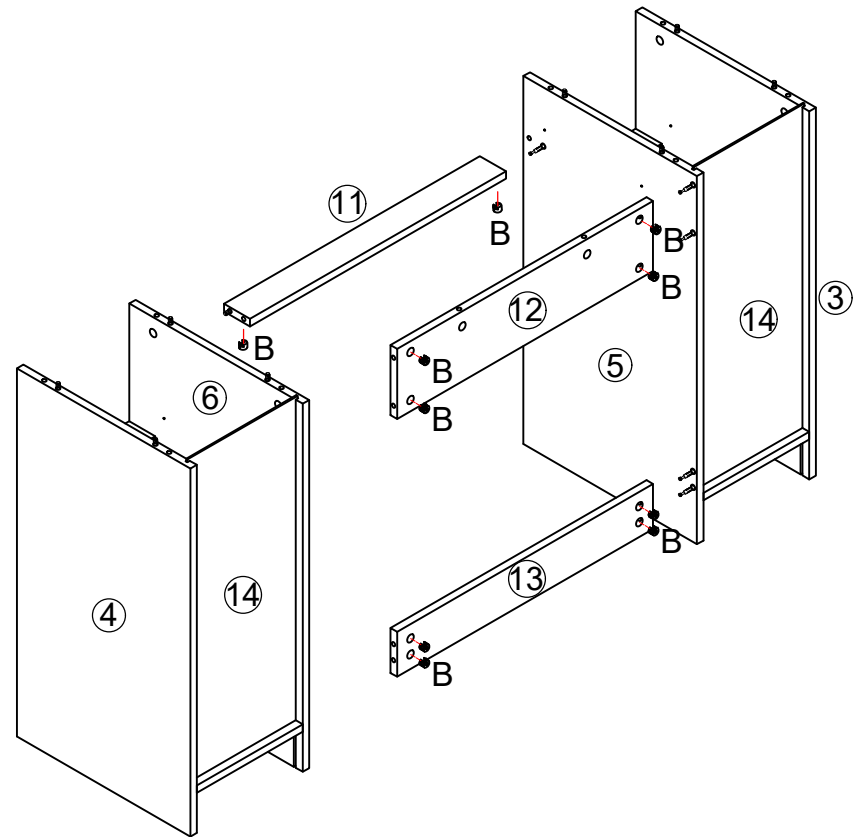
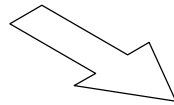
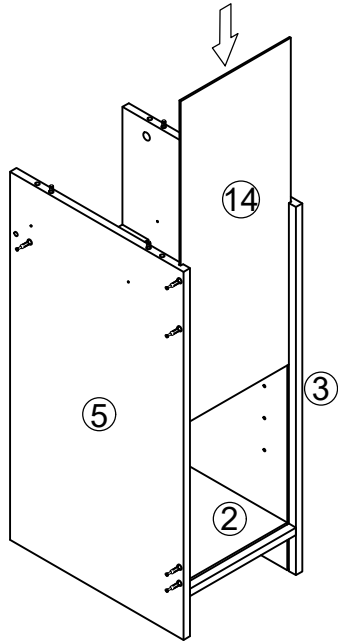
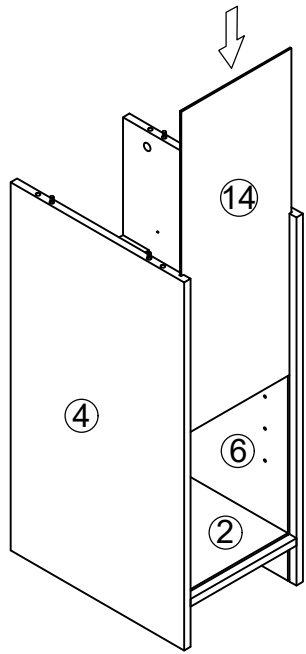

B*10

7

Make sure the arrow on the screw align to the hole on the side.

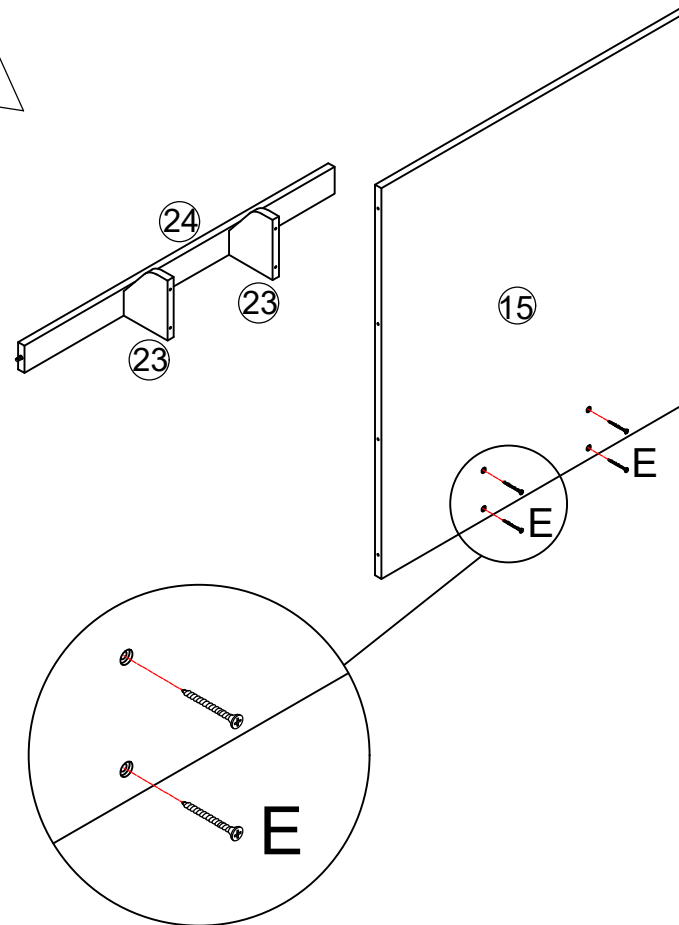
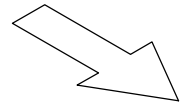
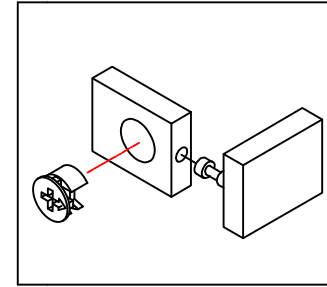
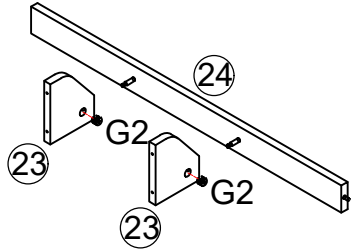

G2*2

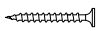

E*4

8

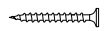
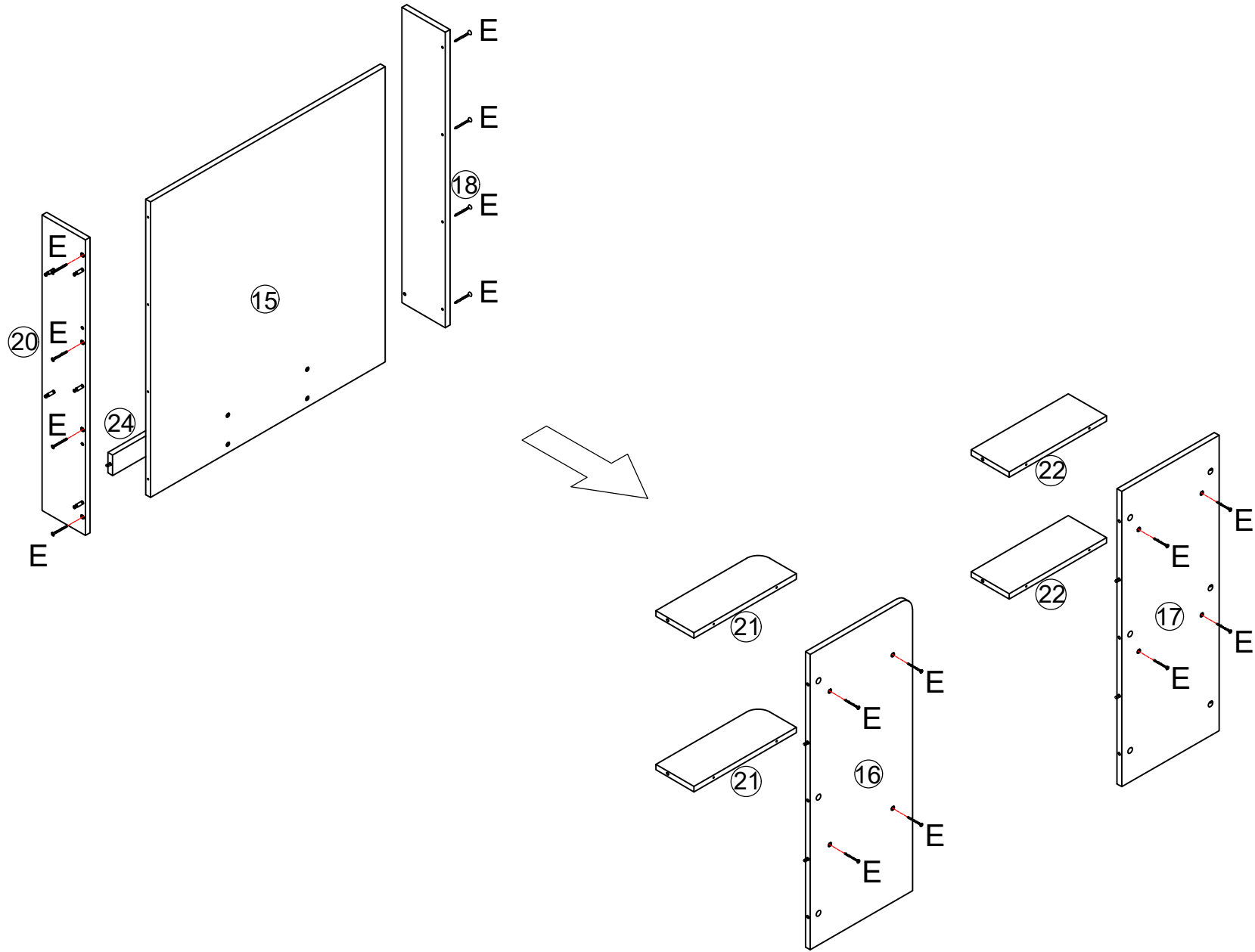

E*16

9

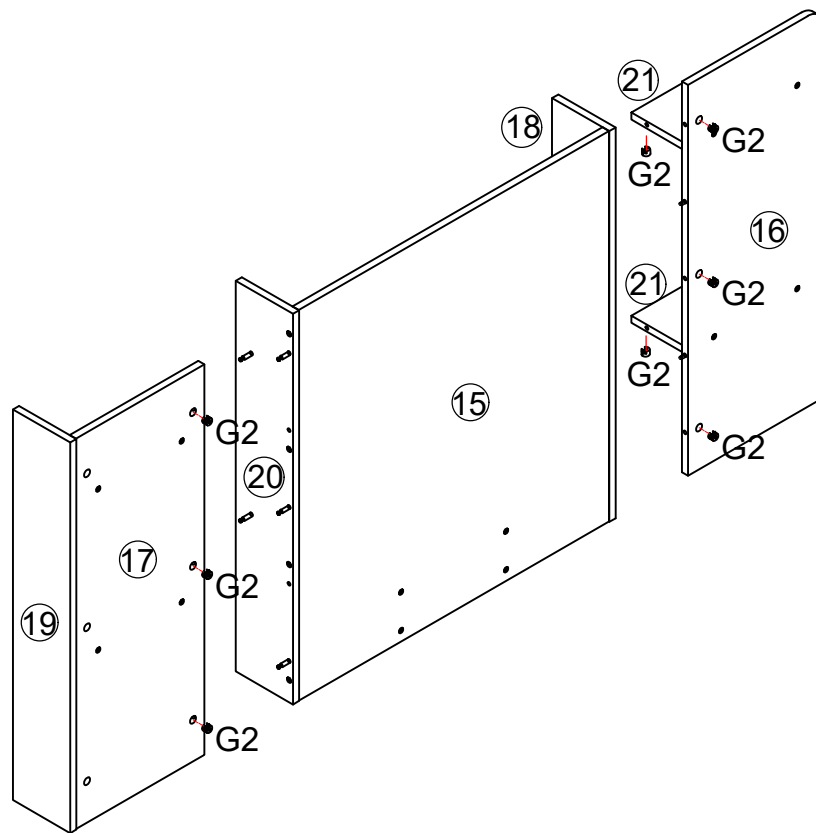
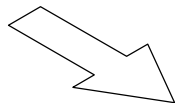
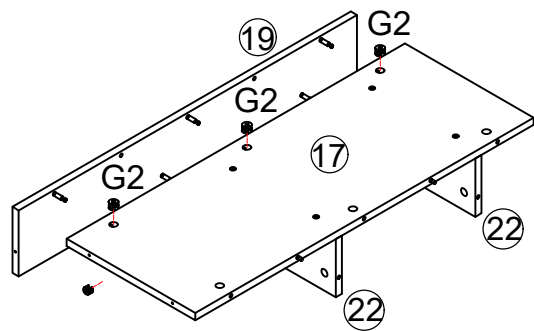

G2*15

10

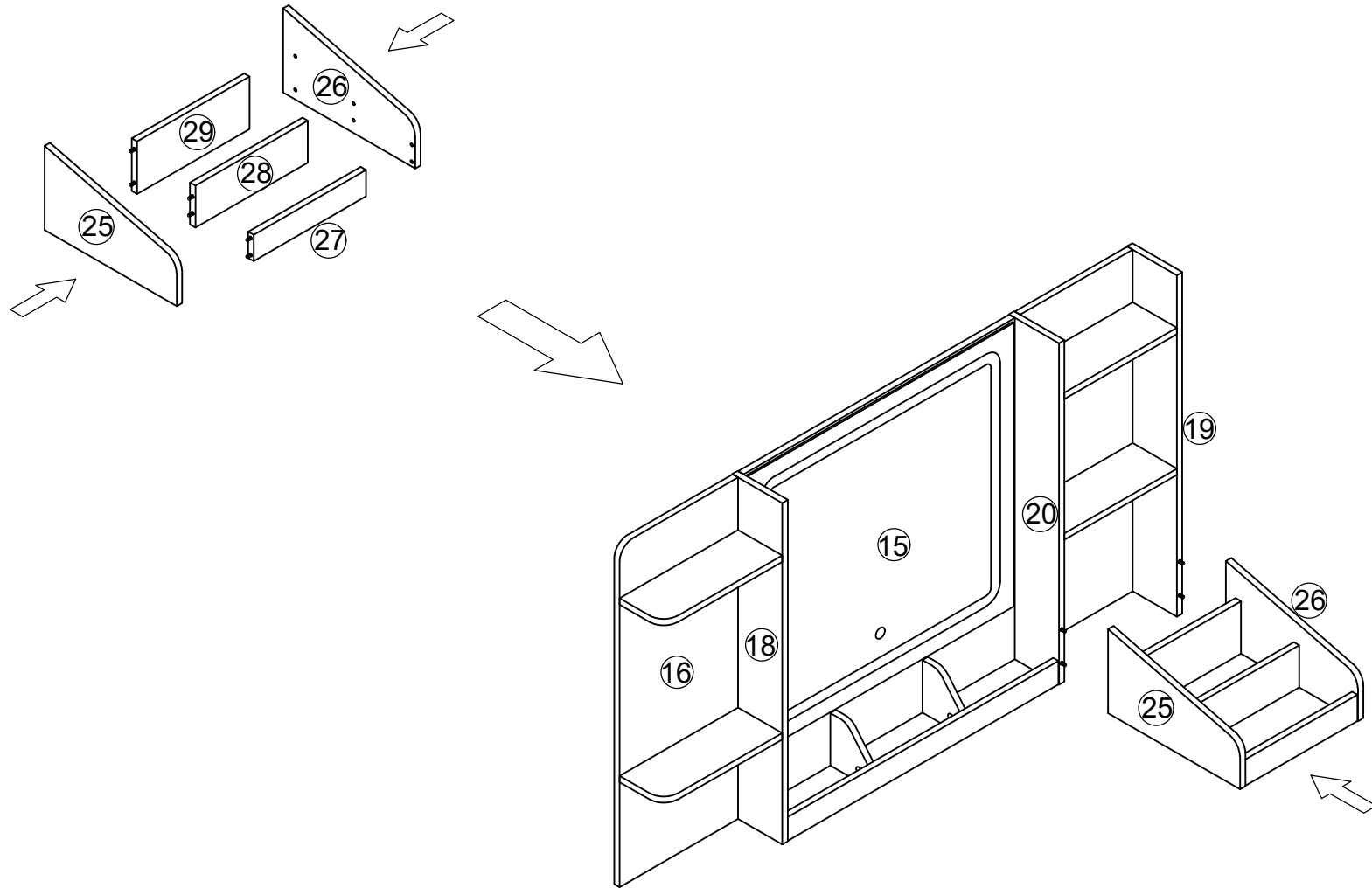

11

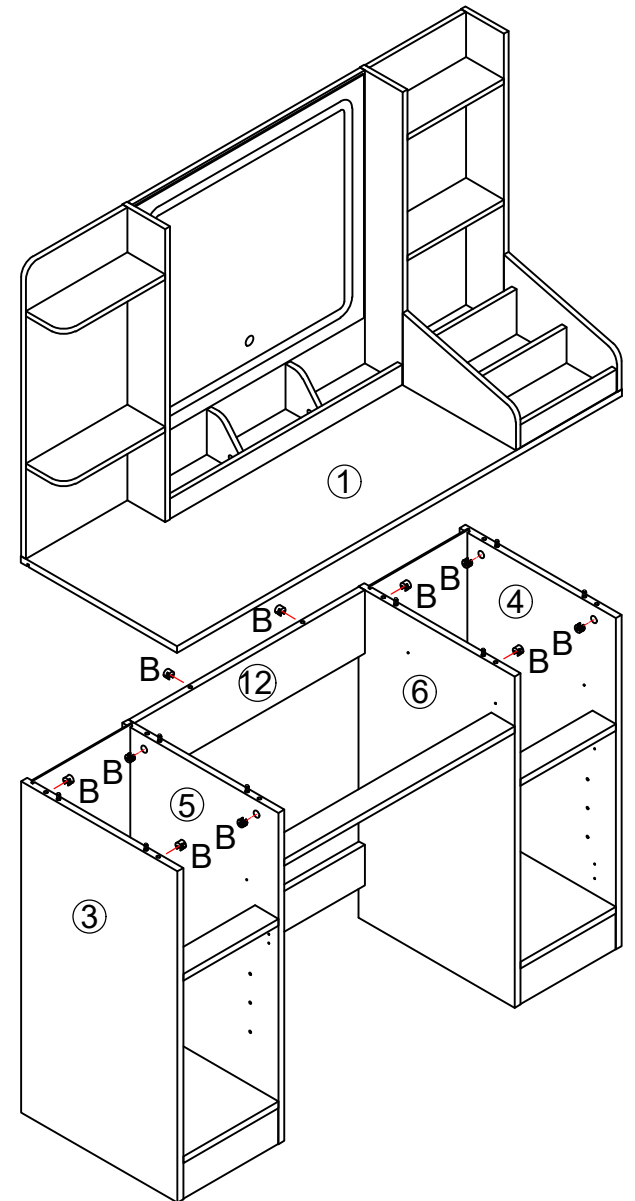
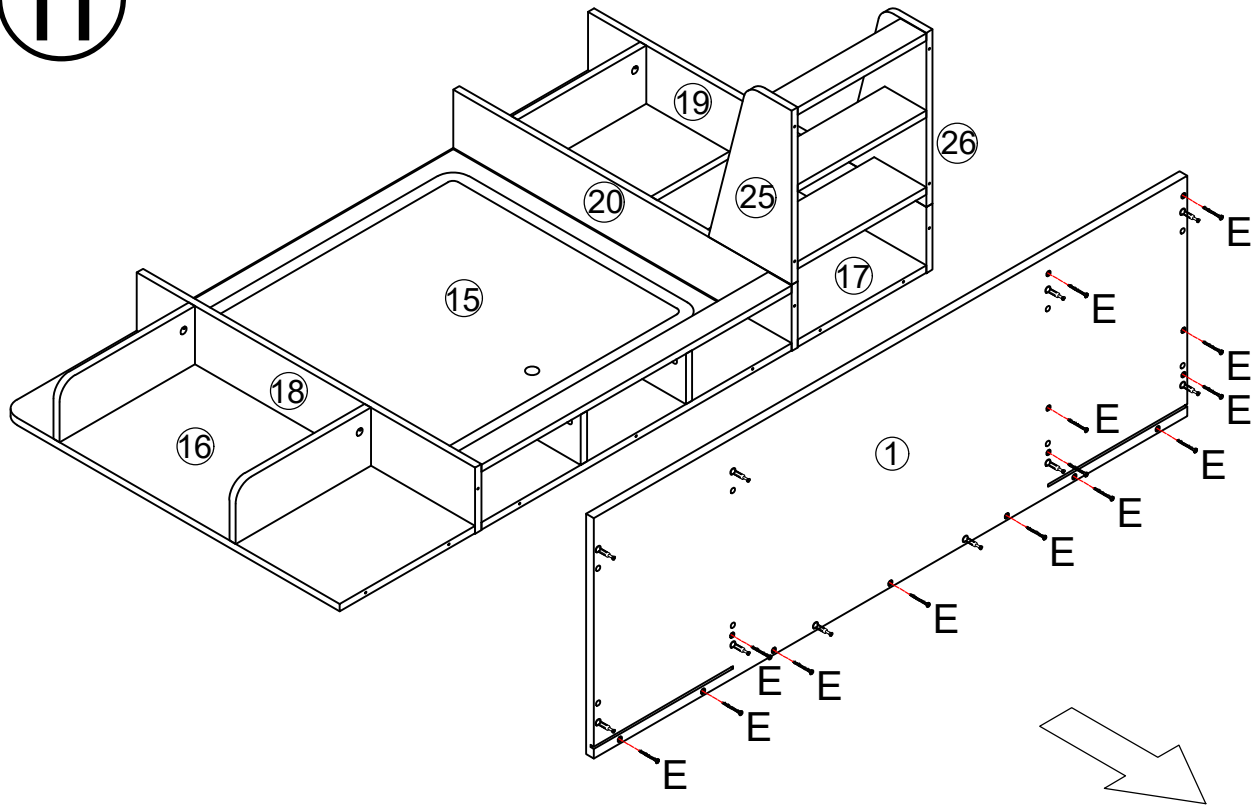

B*10

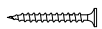

E*14

12

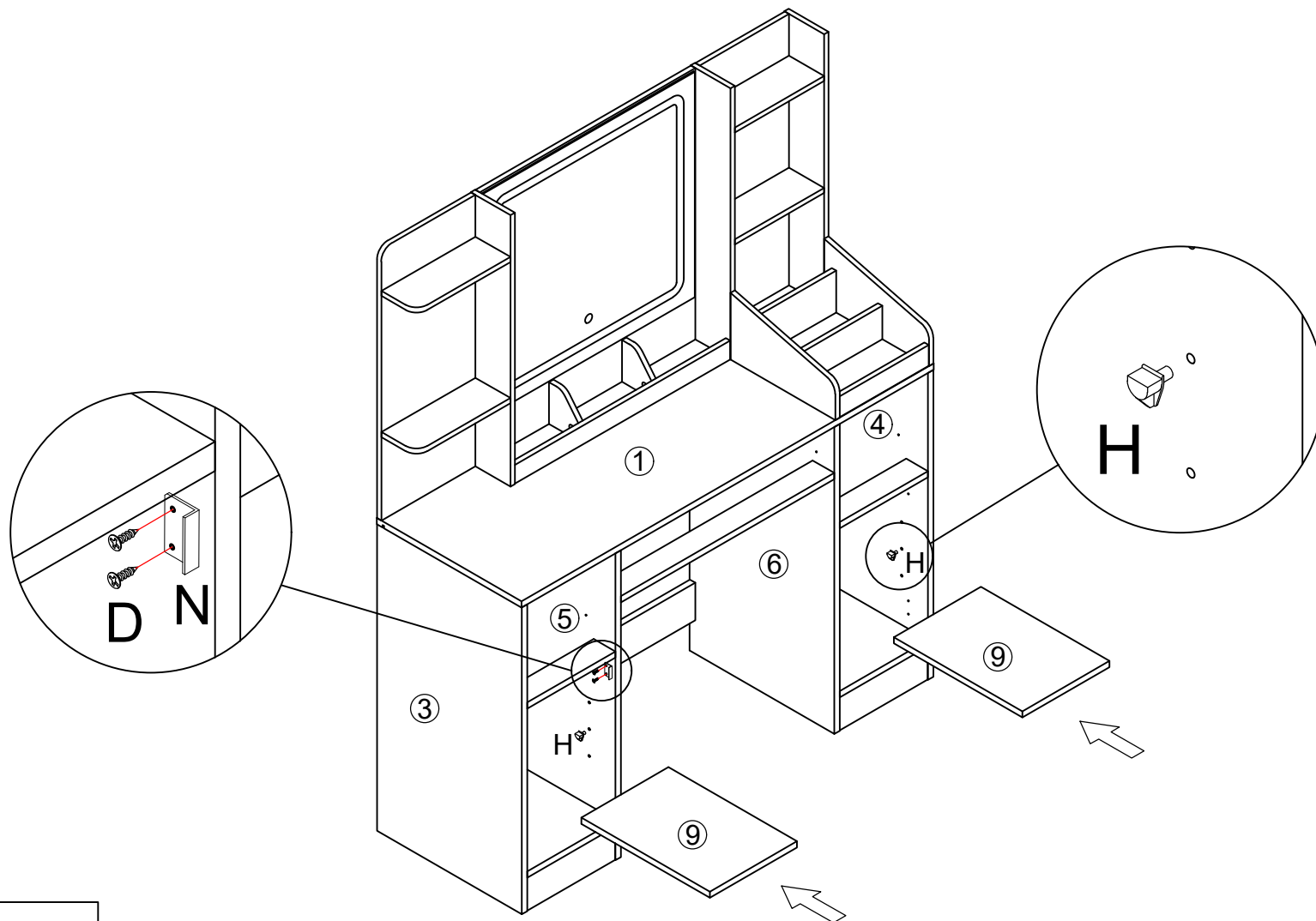

D*4







N*2

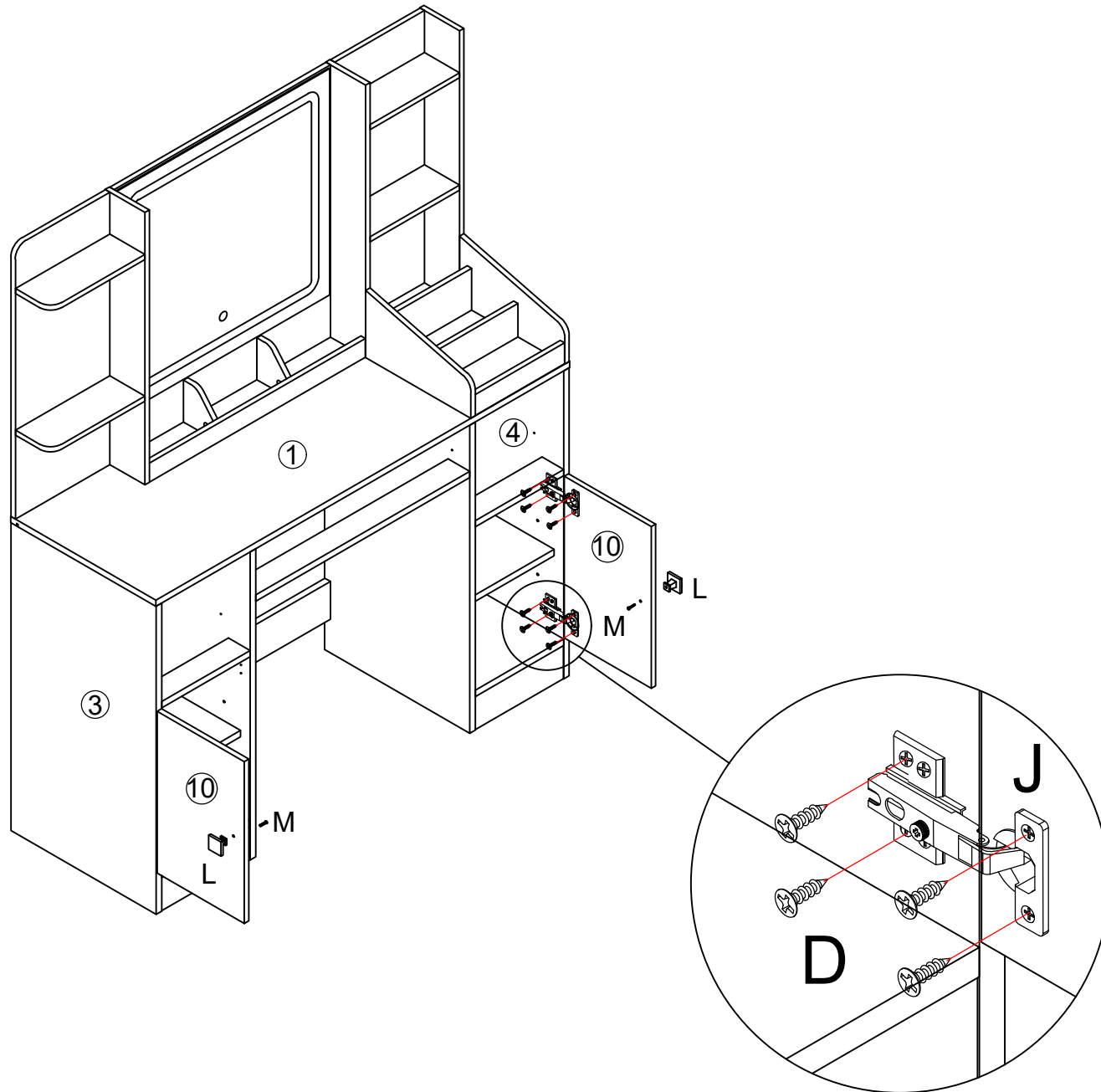

H*8

13



	D*24
	J*4
	L*2
	M*2

14

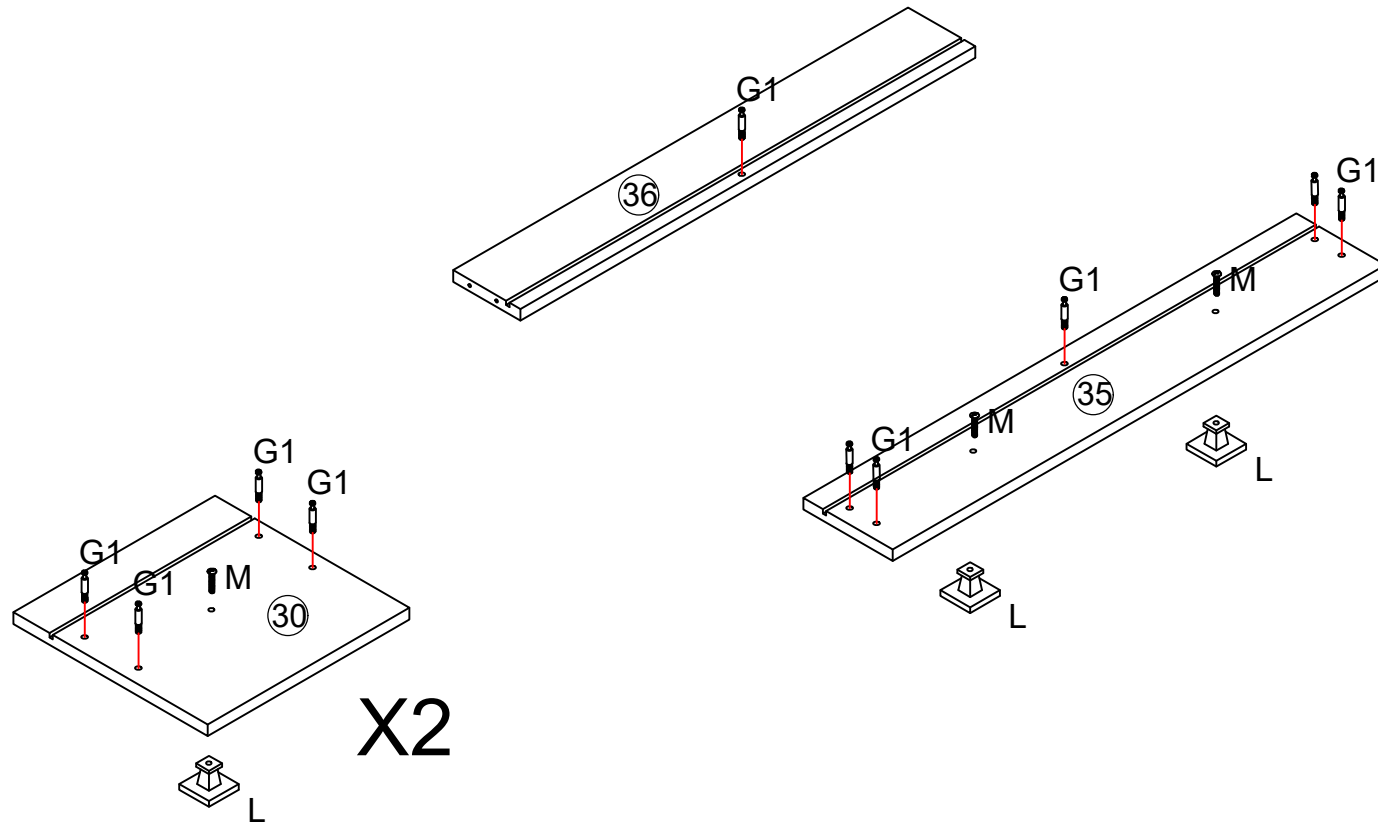

G1*14



L*4



M*4

15

X2

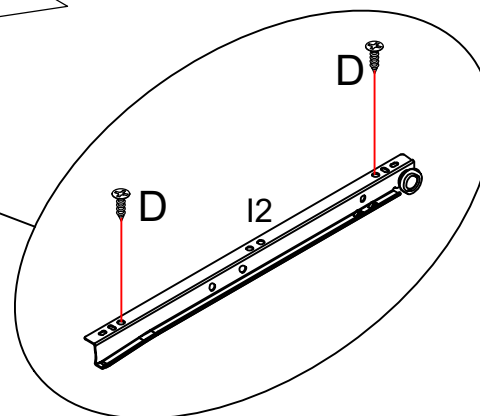
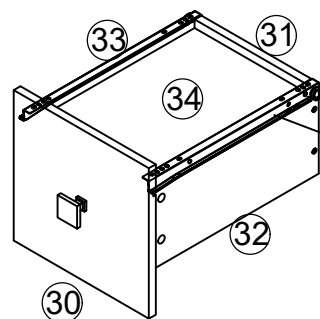
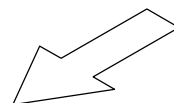
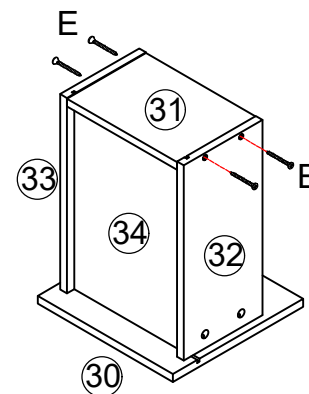
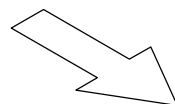
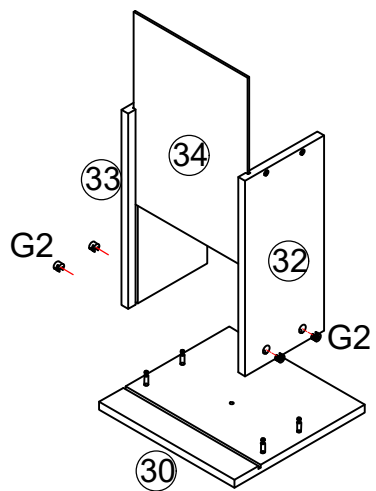

G2*8



D*8

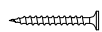

E*8

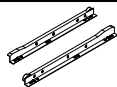

I2*2

16

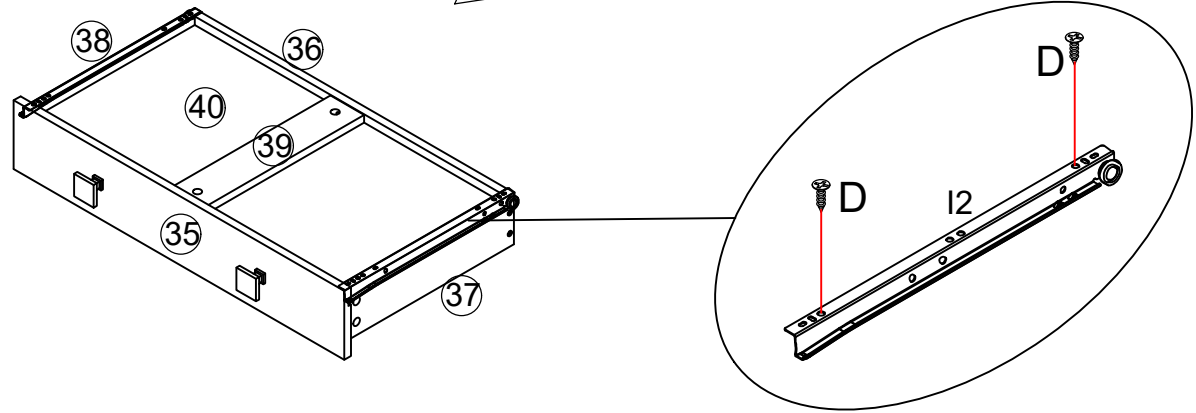
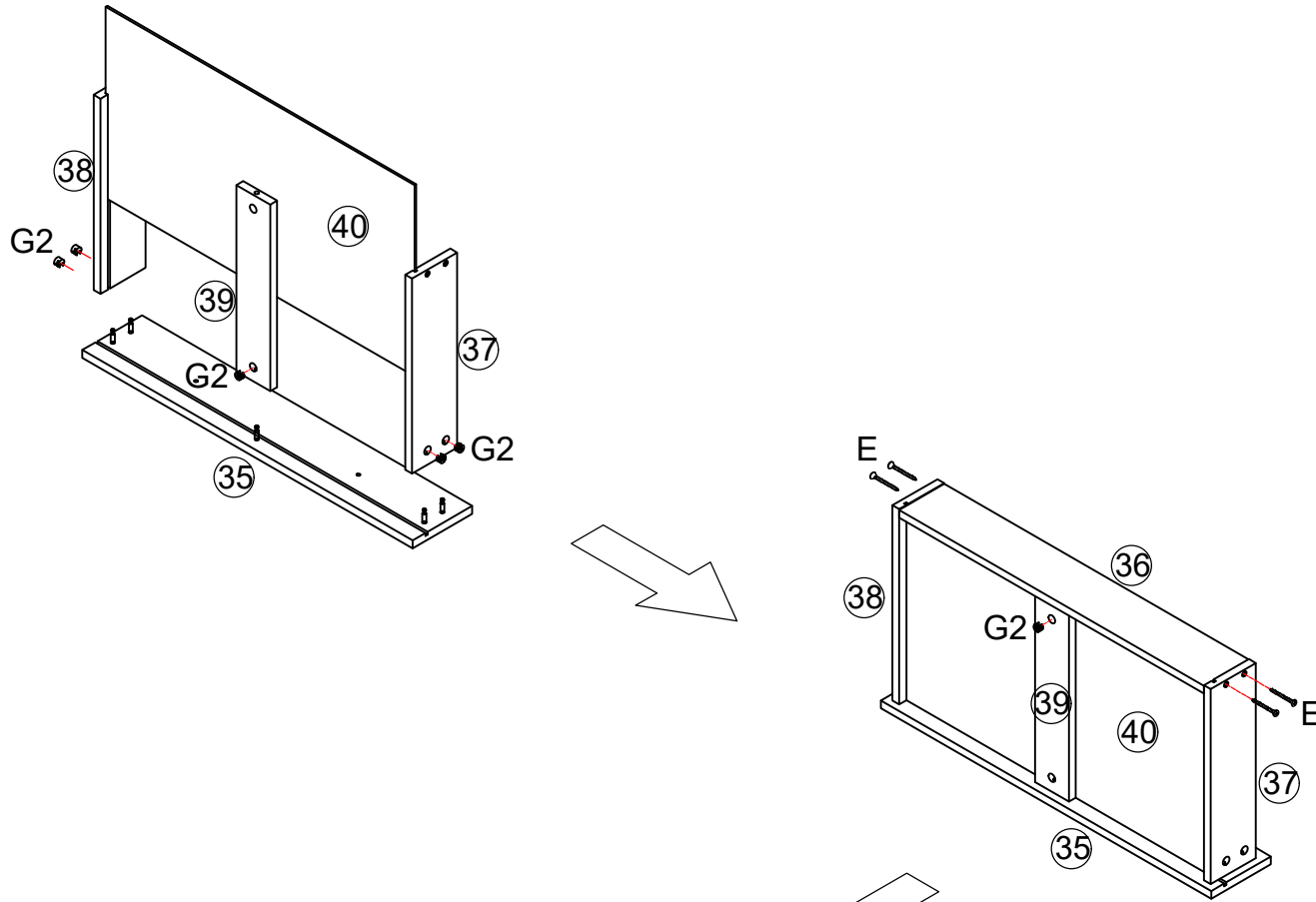

G2*6



D*4

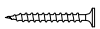

E*4

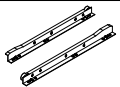

I2*1

17

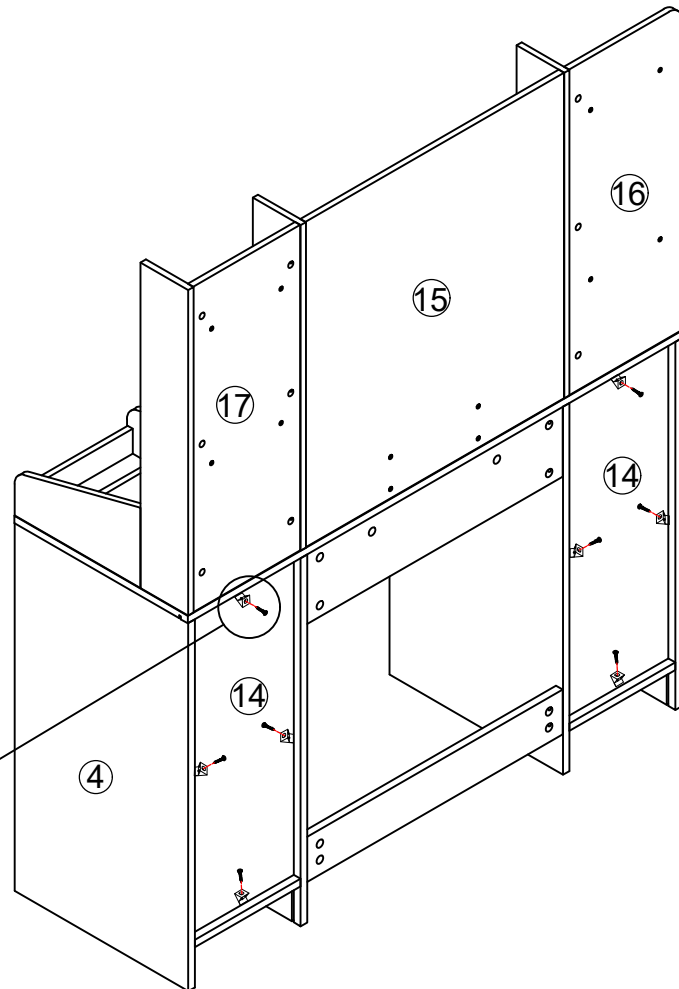
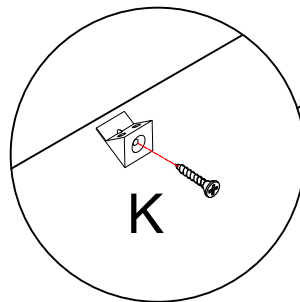
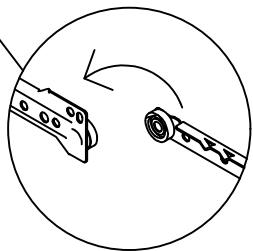
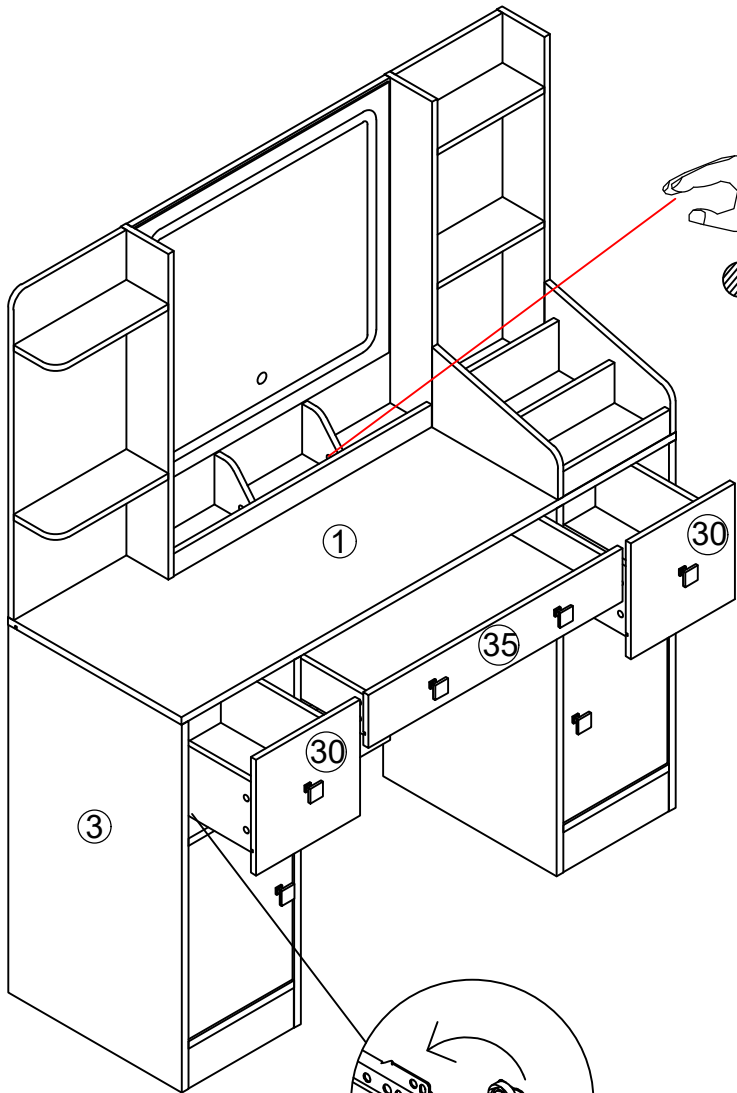

K*8



0*8

18

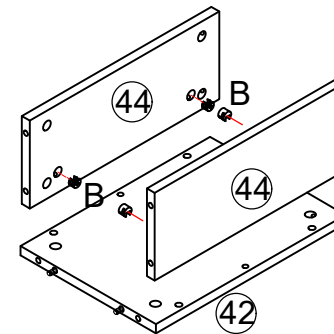
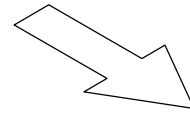
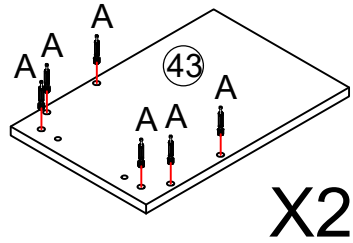
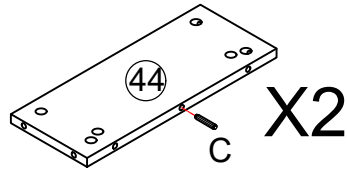
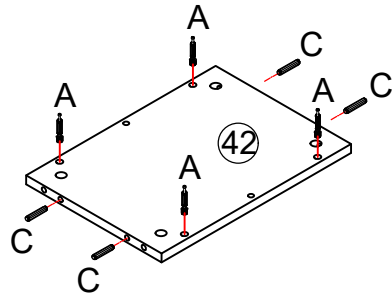

A*16



B*4



C*6

19

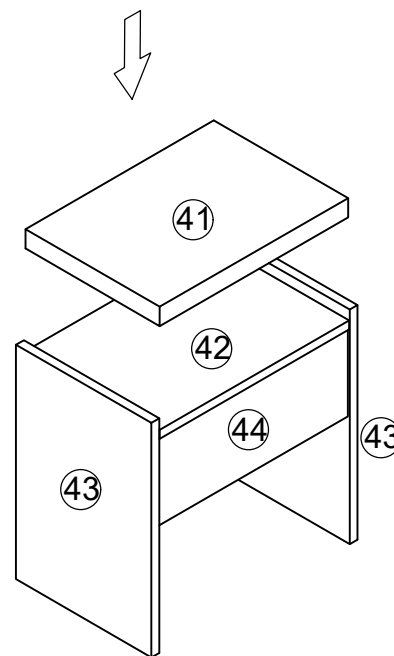
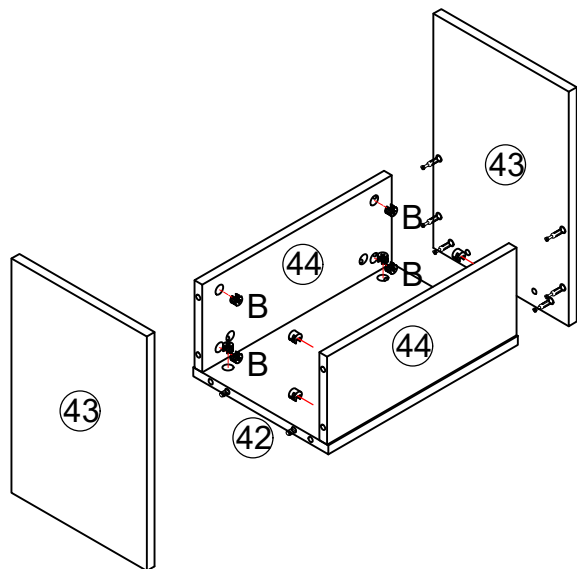

B*12

20

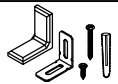
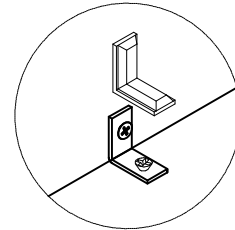
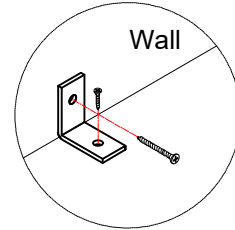
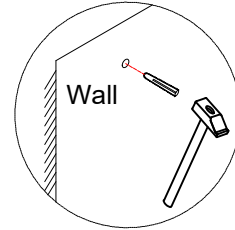
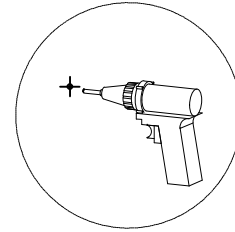
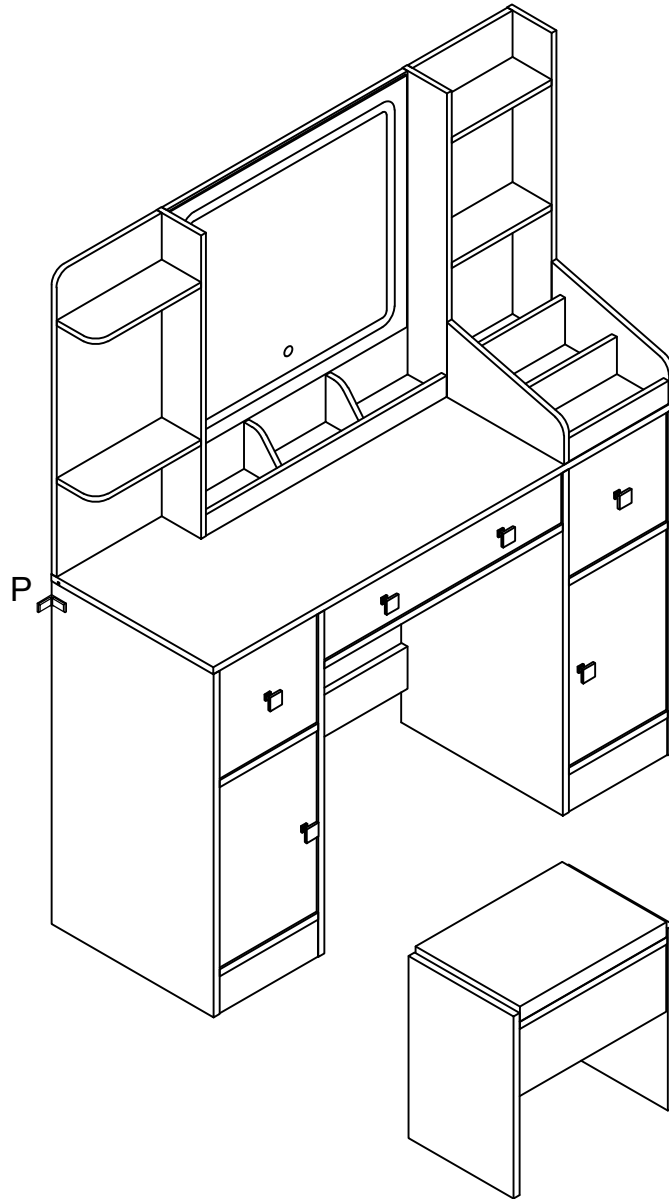

P*2

Please install tip-proof fitting.