

ASSEMBLY INSTRUCTION

PATIO CONVERSATION SET

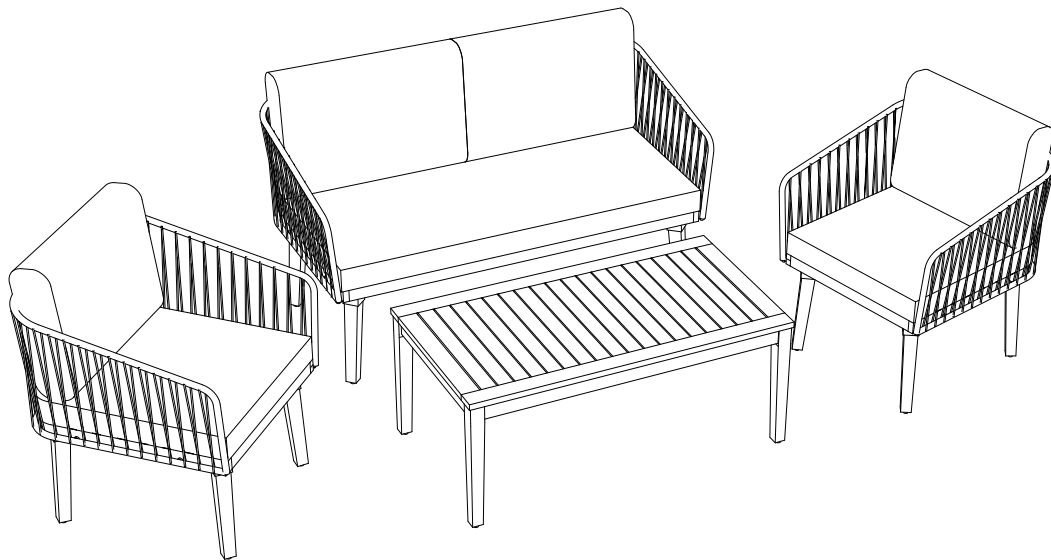

Please read all instructions carefully:

- 1. Have 2 adults on hand for assembly.**
- 2. 50% Tighten before fixing all screws, Allen wrench is recommended instead of an electric drill.**
- 3. Place the item on a flat ground to adjust and make sure it remains stable.**
- 4. Tighten up all screws with tools gradually.**
- 5. If the screws are not aligned with holes during assembly, please loosen all the other screws to 50% and continue the assembly process.**
- 6. If the item is not stable, please loosen all the screws, adjust it on a flat ground and tighten up all screws again.**
- 7. Note : If one or some screws are fully tightened during assembly, chances are the others will not be aligned with holes. In addition, all the holes are designed to be relatively larger to provide more space for the adjustment of the screws.**

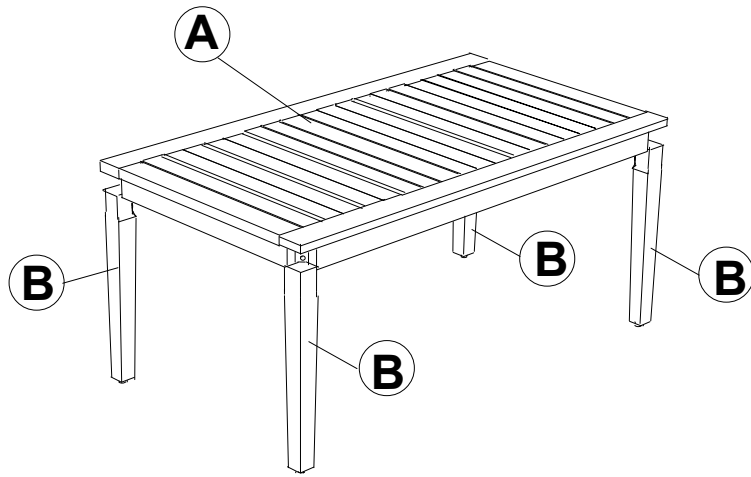

x1

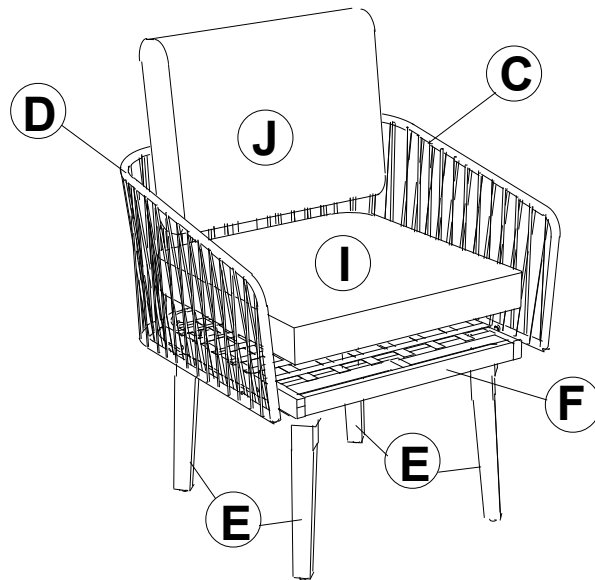



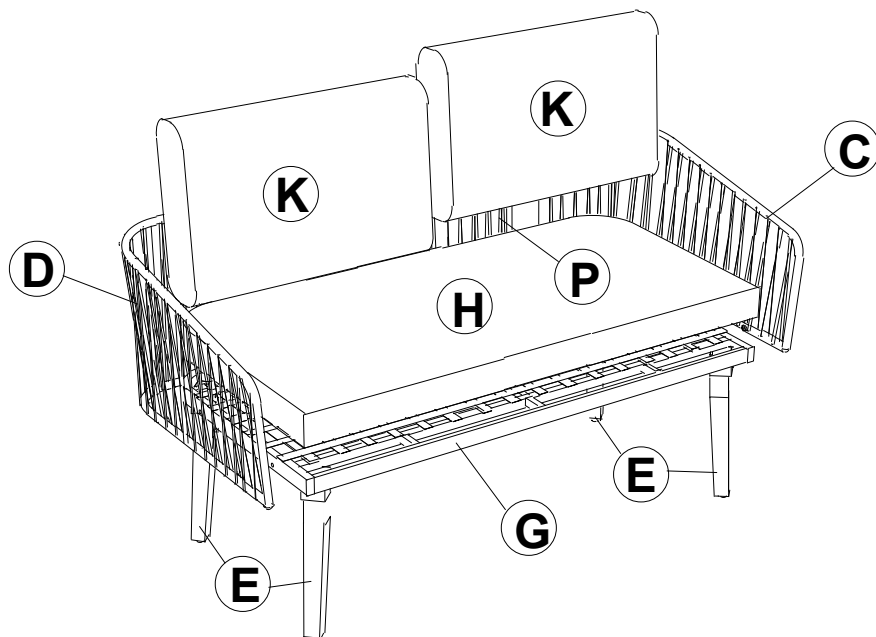



x2

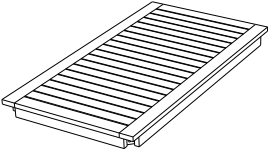

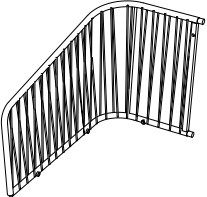

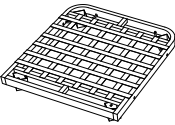
x1

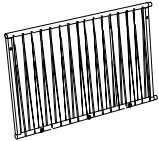
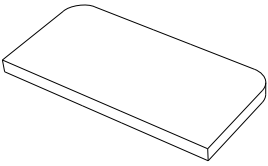
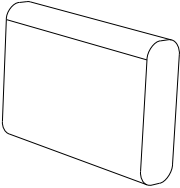
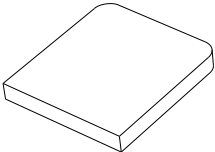
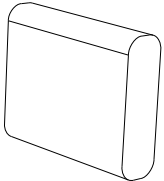



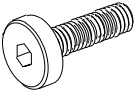
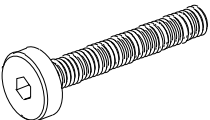
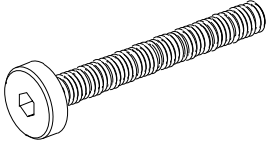

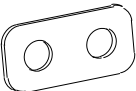
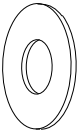
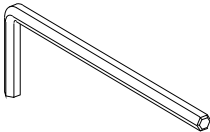

Part List :

| | | | |
|--|---|--|---|
| <p>A</p>  <p>Top Table (1 pc)</p> | <p>B</p>  <p>Leg Table (4 pcs)</p> | <p>C</p>  <p>Left Armless (3 pcs)</p> | <p>D</p>  <p>Right Armless (3 pcs)</p> |
| <p>E</p>  <p>Leg Chair (12 pcs)</p> | <p>F</p>  <p>Seat Chair Frame (2 pcs)</p> | <p>G</p>  <p>Seat Bench Frame (1 pc)</p> | <p>P</p>  <p>Middle Back Bench Frame (1 pc)</p> |
| <p>H</p>  <p>Seat Bench Cushion (1 pc)</p> | <p>K</p>  <p>Back Bench Cushion (2 pcs)</p> | <p>I</p>  <p>Seat Chair Cushion (2 pcs)</p> | <p>J</p>  <p>Back Chair Cushion (2 pcs)</p> |

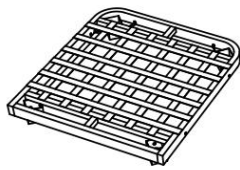
Hardware list:

| | | | |
|--|--|--|--|
| <p>1</p>  <p>Extra (1 pc) Bolt M6x15 (8 pcs)</p> | <p>2</p>  <p>Extra (2 pcs) Bolt M6x40 (21 pcs)</p> | <p>3</p>  <p>Extra (2 pcs) Bolt M6x50 (8 pcs)</p> | <p>4</p>  <p>Extra (2 pcs) Screw Bolt M6x25 (24 pcs)</p> |
| <p>5</p>  <p>Connecting Flat (4 pcs)</p> | <p>6</p>  <p>Extra (3 pcs) Flat Washer M6 (61 pcs)</p> | <p>7</p>  <p>Allen Key (2 pcs)</p> | |

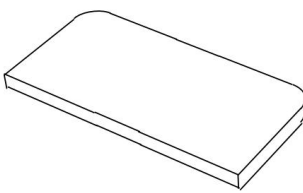
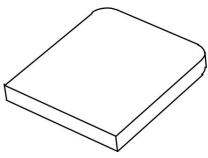
CARTON CONTENT:

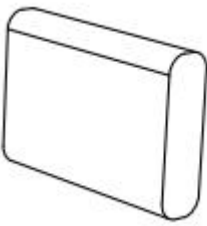
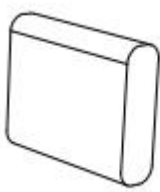
| | | | |
|---|---|---|--|
| A  Top Table (1 pc) | B  Leg Table (4 pcs) | E  Leg Chair (12 pcs) | E  Seat Chair Frame (2 pcs)  Hardware |
| G  Seat Bench Frame (1 pc) | P  Middle Back Bench Frame (1 pc) | H  Seat Bench Cushion (1 pc) | I  Seat Chair Cushion (2 pcs) |
| C  Left Armless (3 pcs) | D  Right Armless (3 pcs) | | |
| K  Back Bench Cushion (2 pcs) | J  Back Chair Cushion (2 pcs) | | |

STEP 1

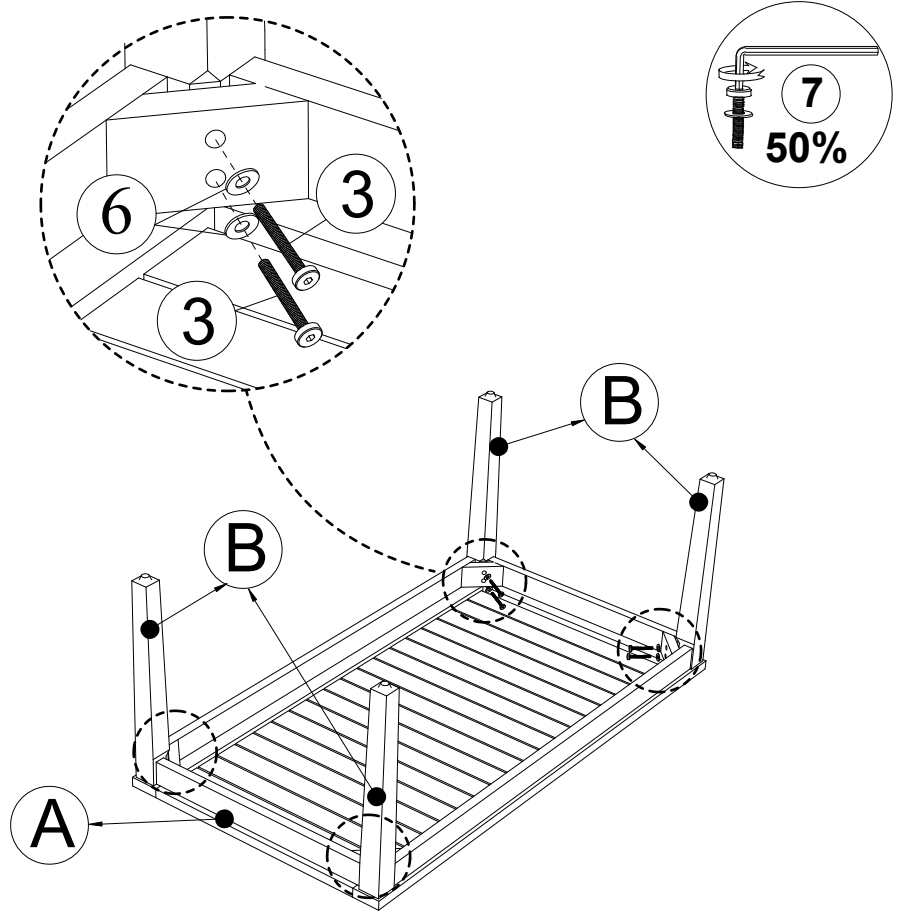
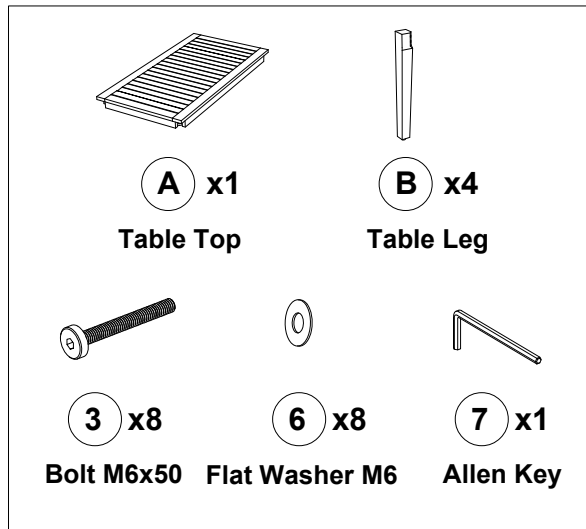

Connect Top Table (A) & Leg Table (B), tighten Bolt (3) & flat washer (6) with Allen Key (7)

STEP 2

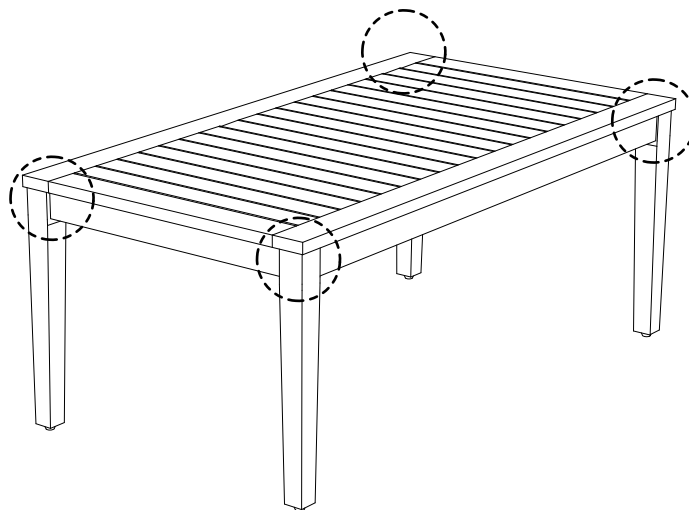
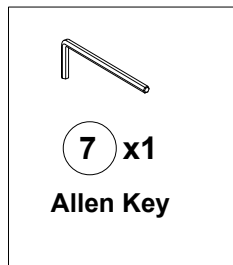

Put Table upright, firmly tighten Bolts with Allen Key (7)

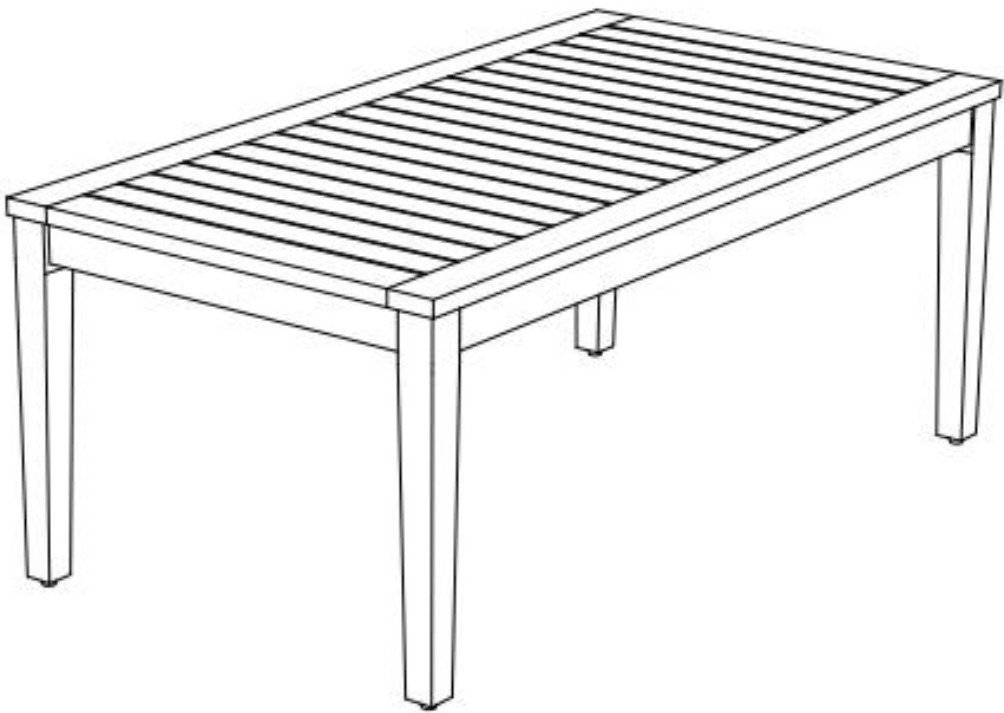

Finish Table

STEP 3

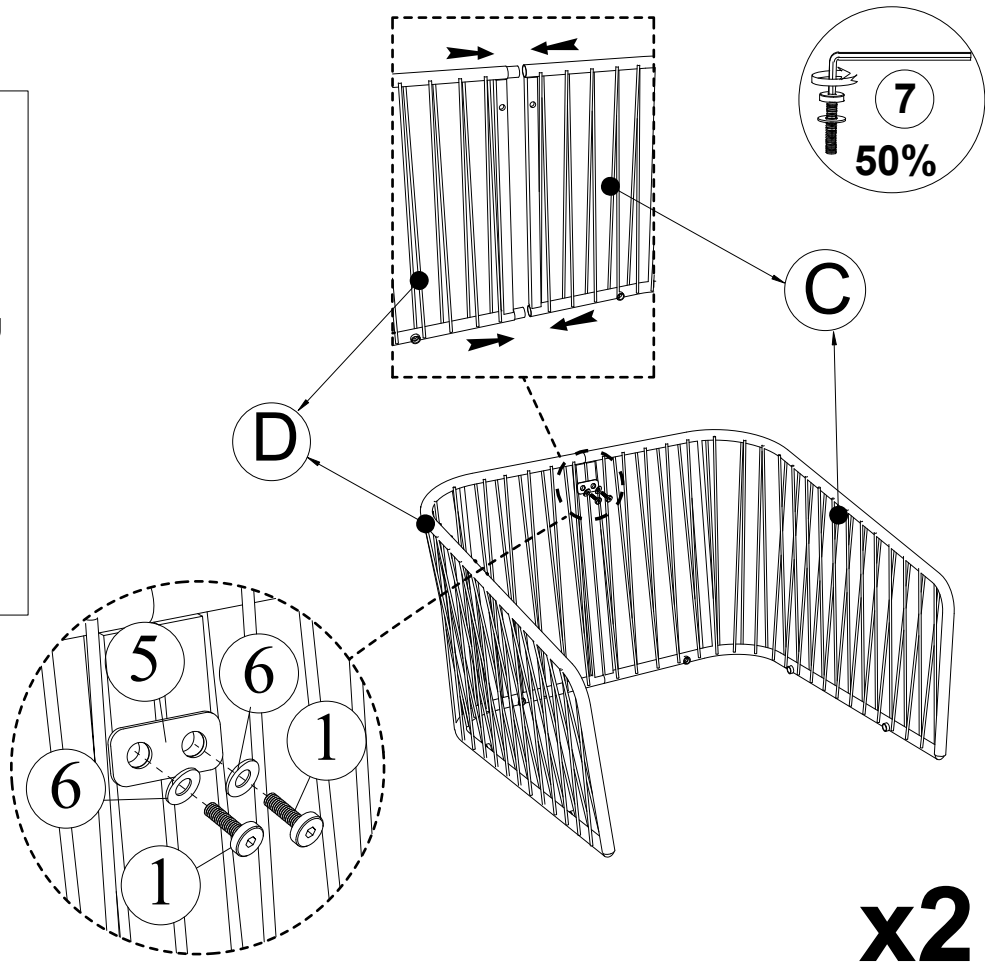
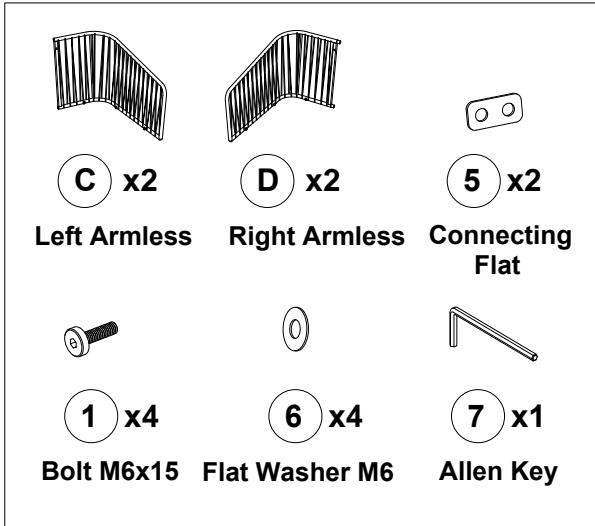

Push and connect Left Armless (C) & Right Armless (D), tightening Bolt (1) & Flat Washer (6) & Allen Key (7).

STEP 4

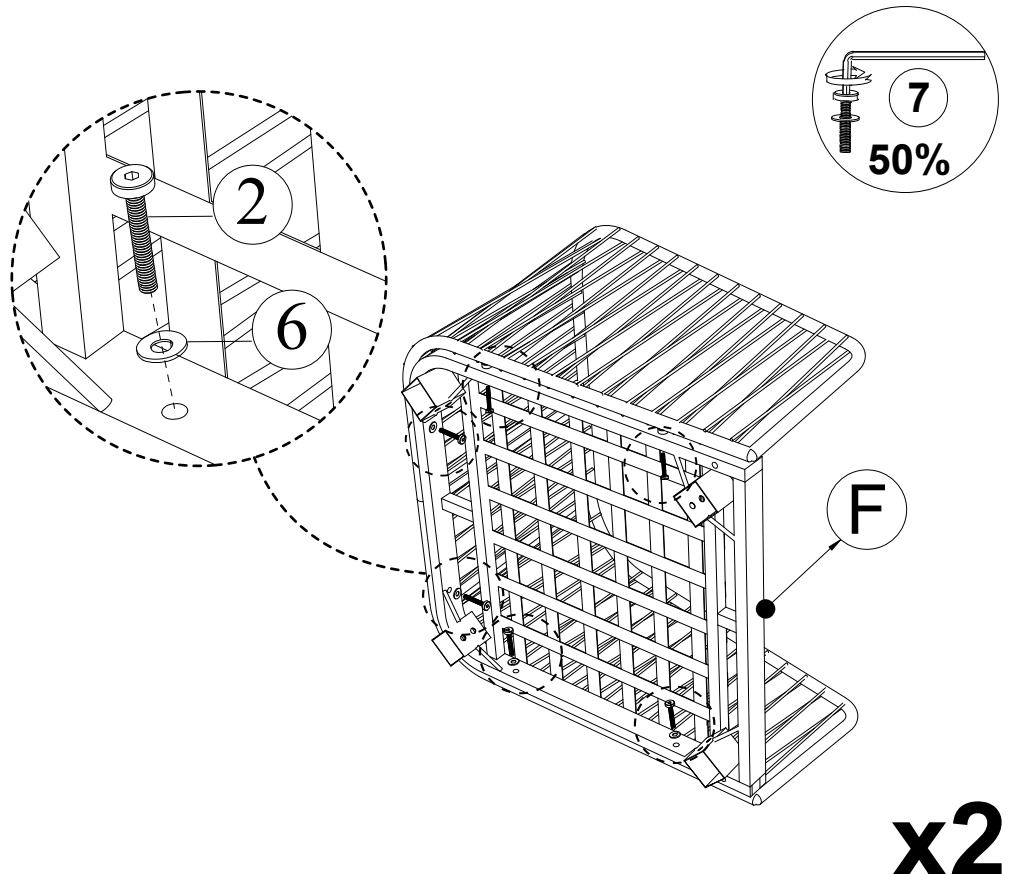
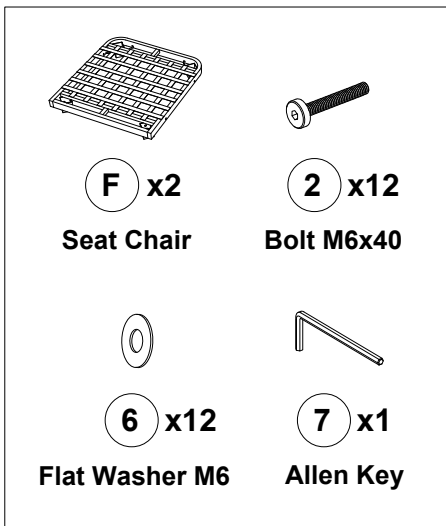

Connect the part from step 3 & Seat Chair (F), tighten Bolt (2) & Flat Washer (6) with Allen Key (7).

STEP 5

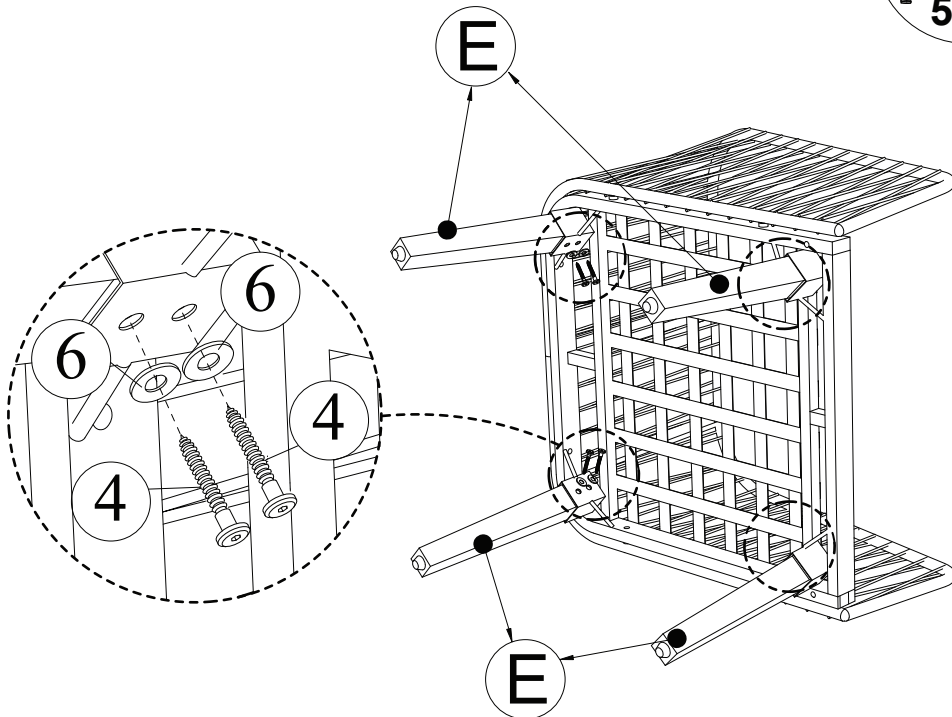
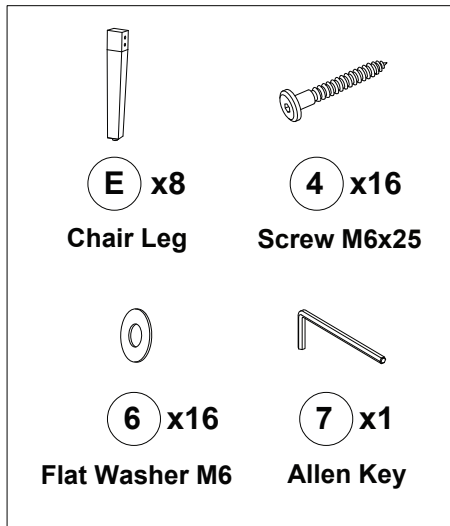
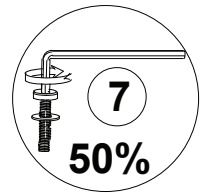

x2

Connect The part from Step 4 & Leg Chair (E), tighten Screw (4) & Flat Washer (6) with Allen Key (7).

STEP 6

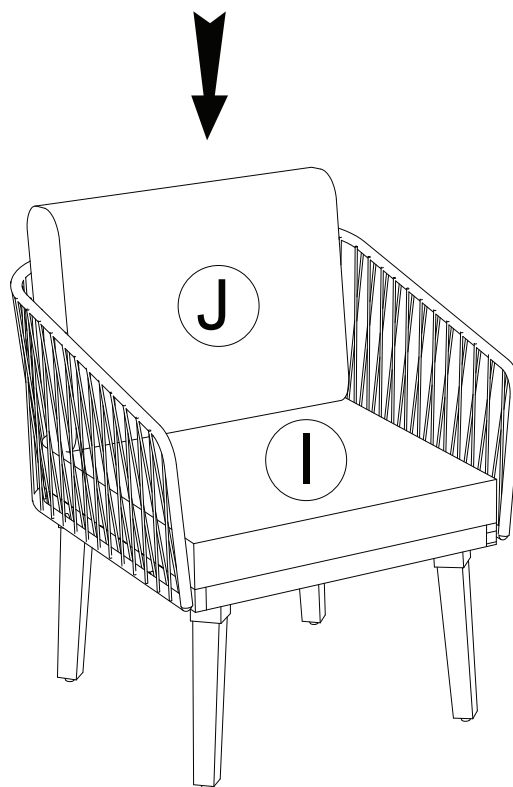
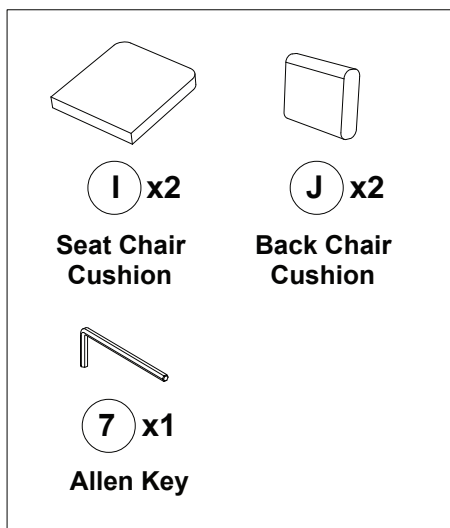
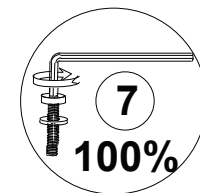

x2

Put Chair upright, firmly tighten Bolts with Allen Key (7)
Set up the Cushions (I)+(J) to finish Chair.

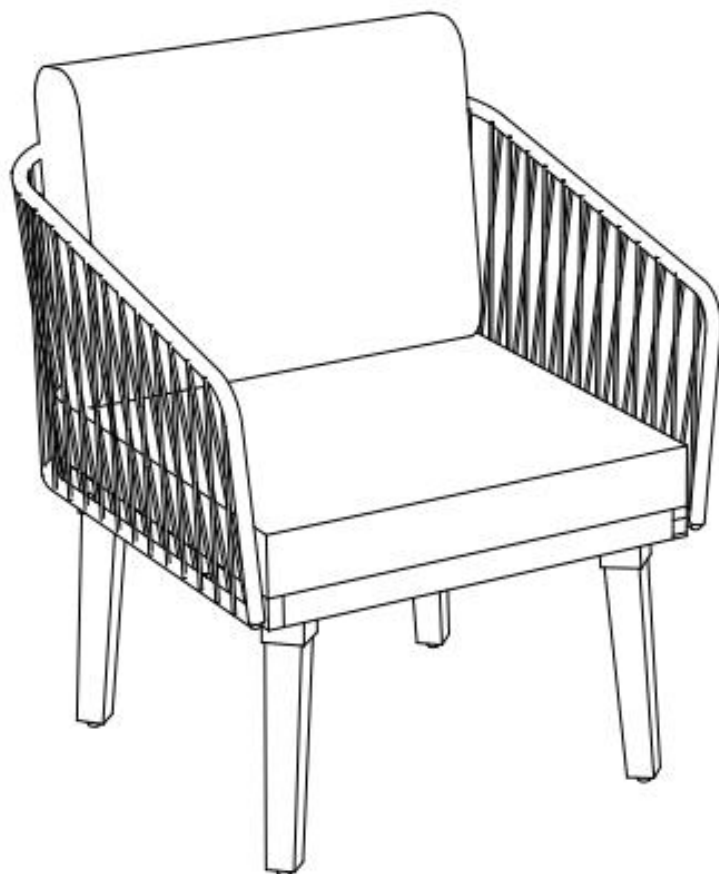

Finish Chair

x2

STEP 7

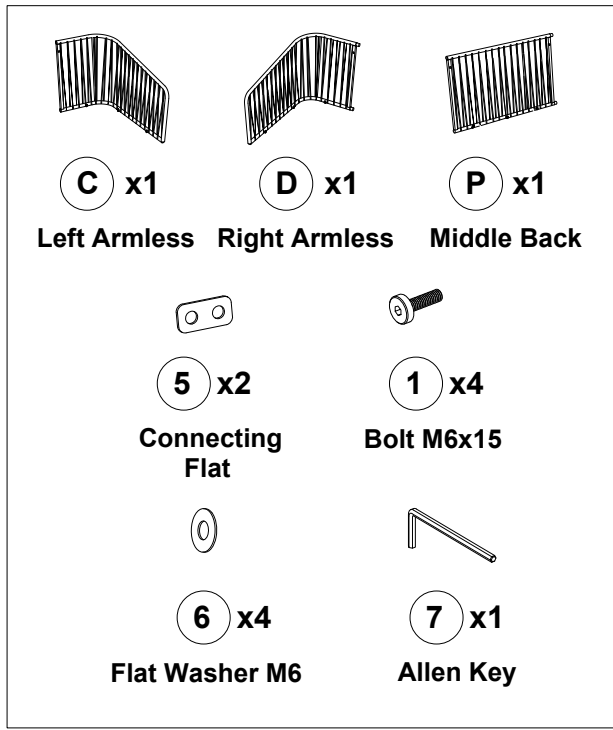

C x1 Left Armless
D x1 Right Armless
P x1 Middle Back
5 x2 Connecting Flat
1 x4 Bolt M6x15
6 x4 Flat Washer M6
7 x1 Allen Key

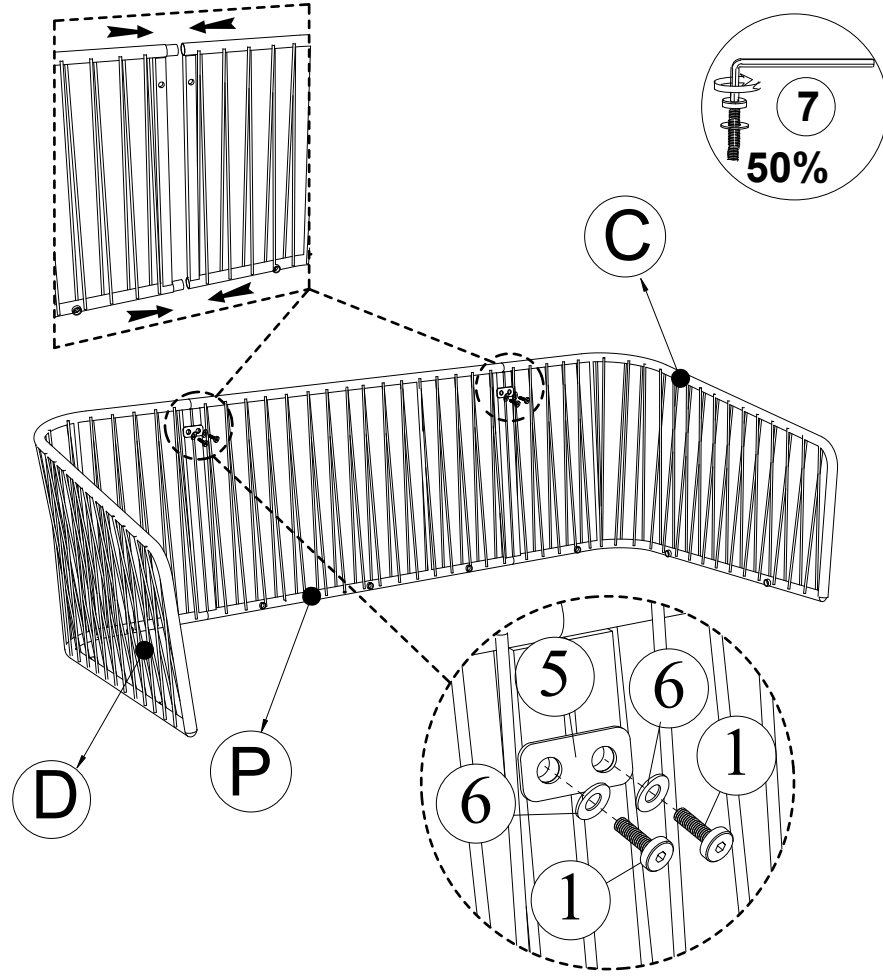

Push and connect Left Armless (C) & Right Armless (D) & Middle Back (P) tightening Bolt (1) & Flat Washer (6) & Allen Key (7).

STEP 8

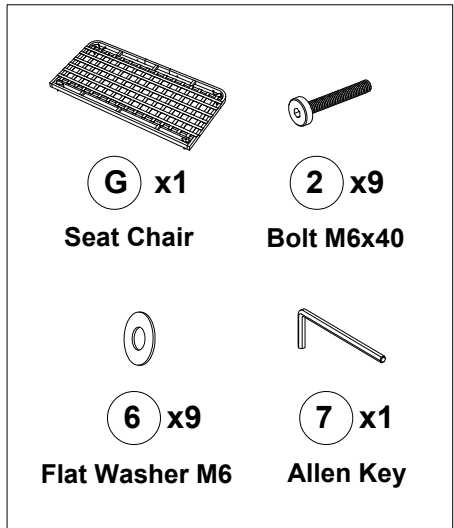

G x1 Seat Chair
2 x9 Bolt M6x40
6 x9 Flat Washer M6
7 x1 Allen Key

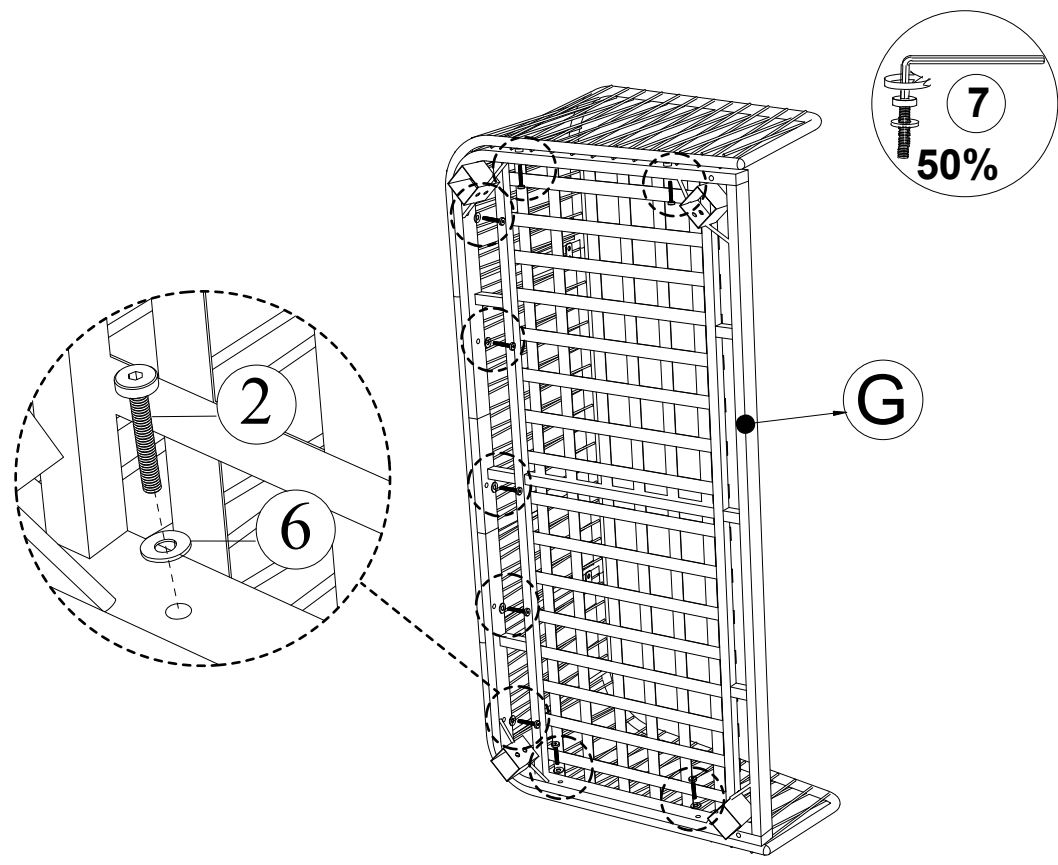

Connect the part from step 7 & Seat Bench (G), tighten Bolt (2) & Flat Washer (6) with Allen Key (7).

STEP 9

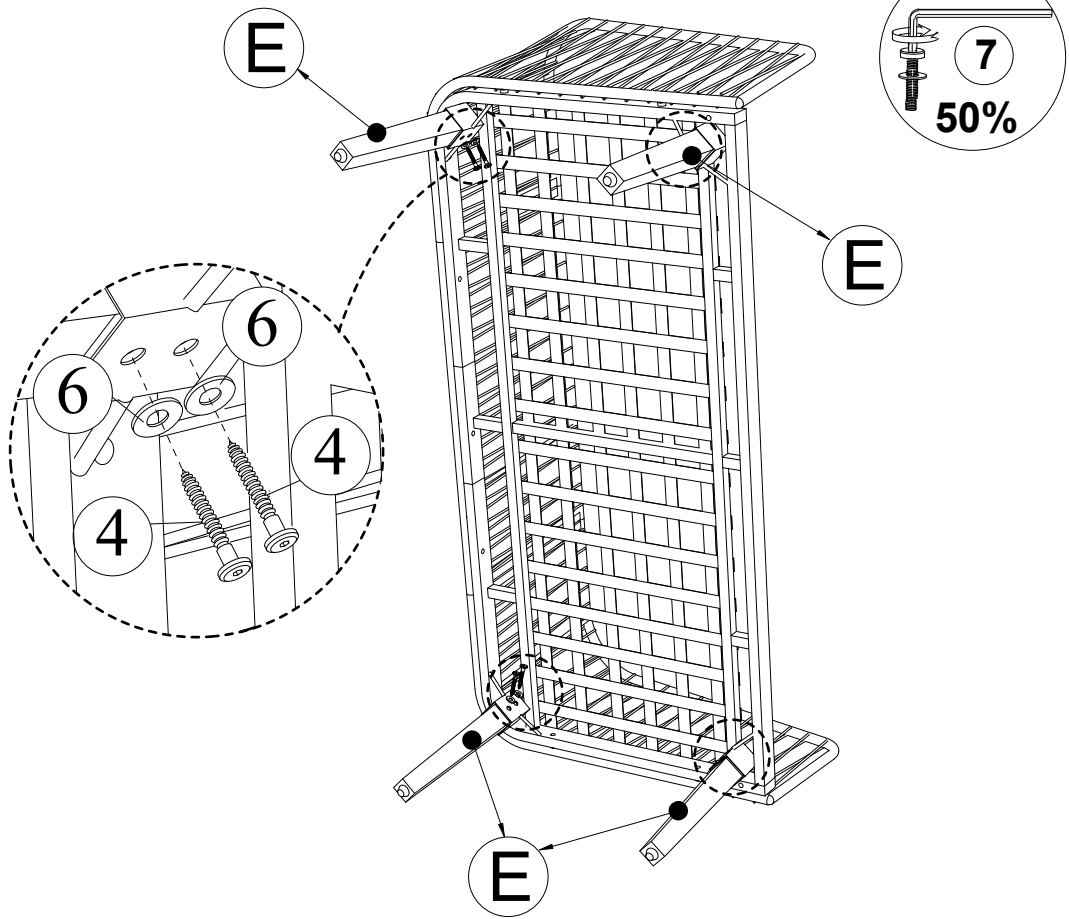
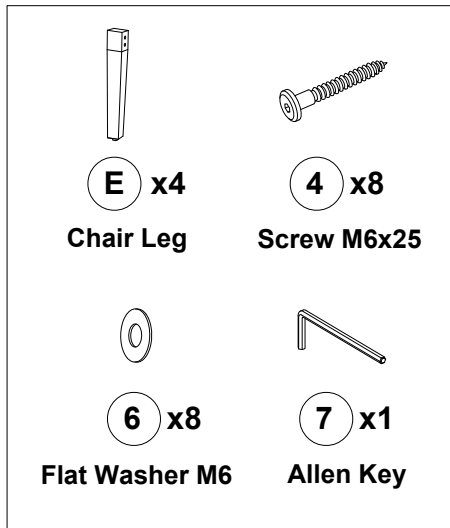

Connect The part from Step 8 & Leg Chair (E), tighten Bolt (2) & Flat Washer (6) with Allen Key (7).

STEP 10

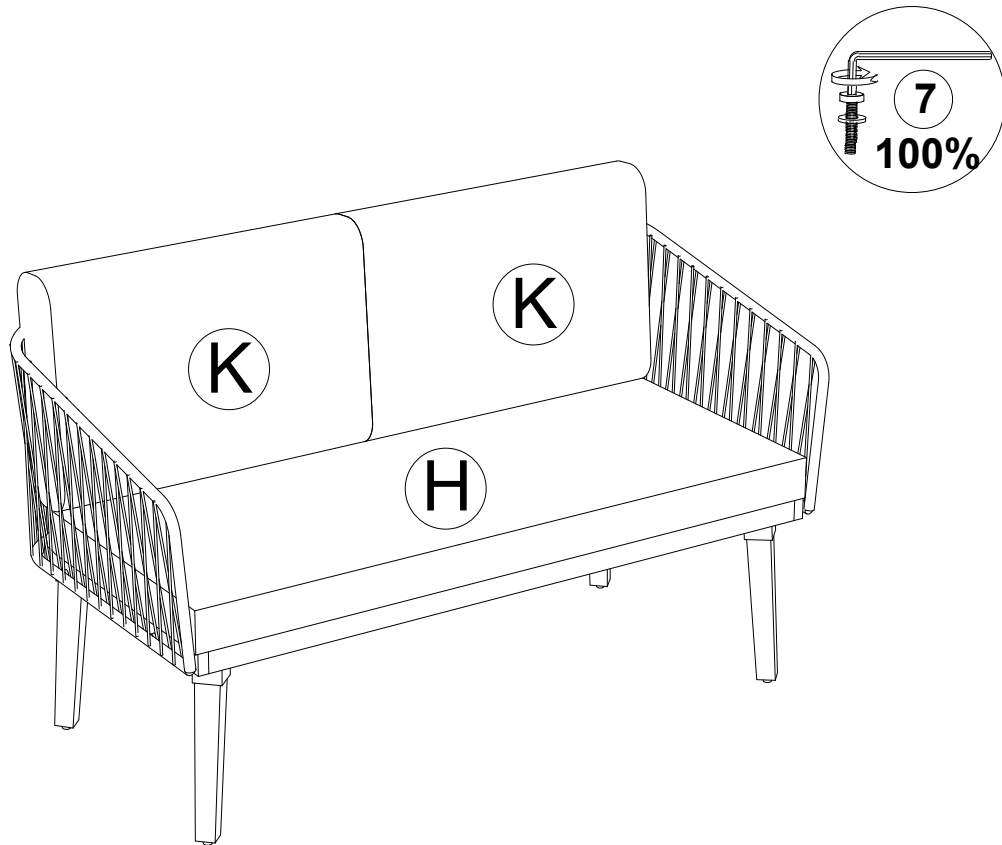
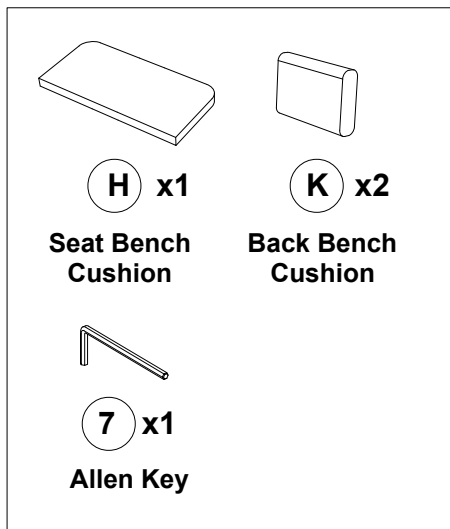

Put Chair upright, firmly tighten Bolts with Allen Key (7)
Set up the Cushions (H)+(K) to finish Bench.

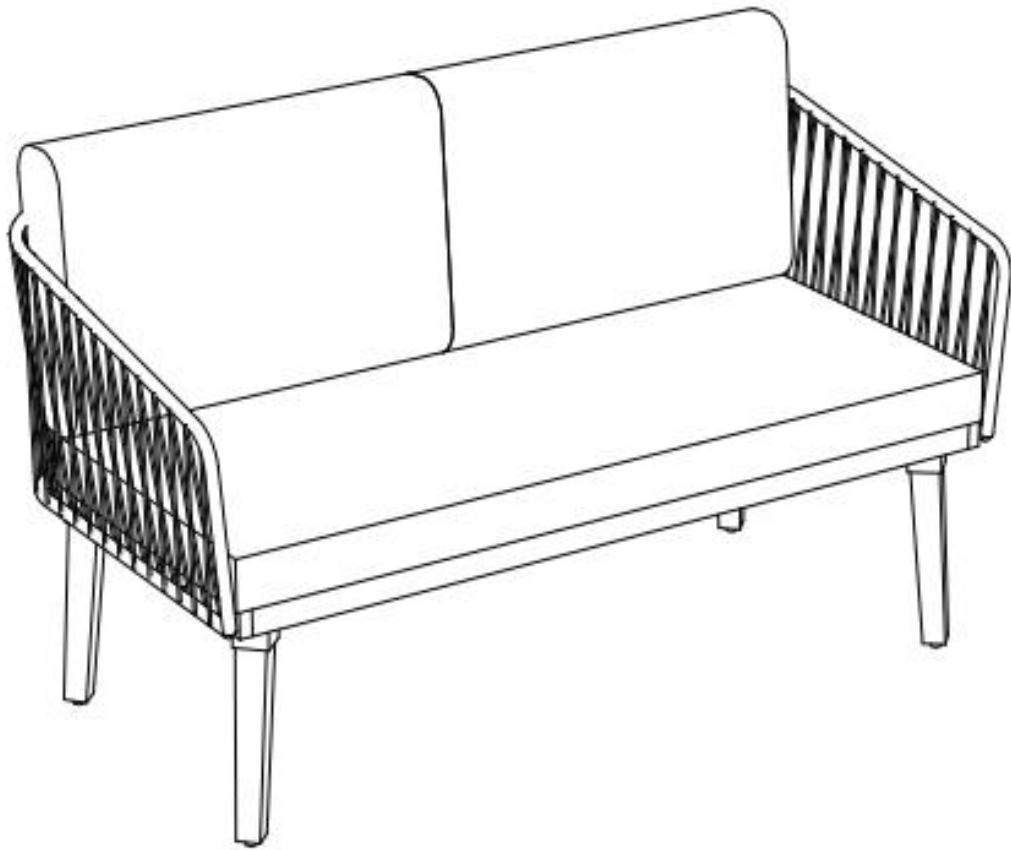

Finish Loveseat

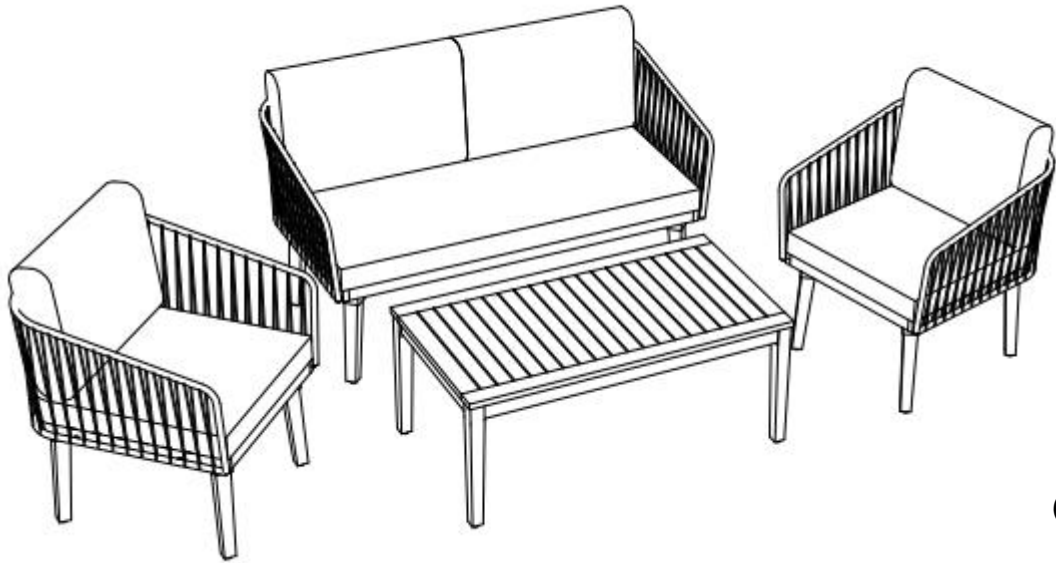

OPTION 1

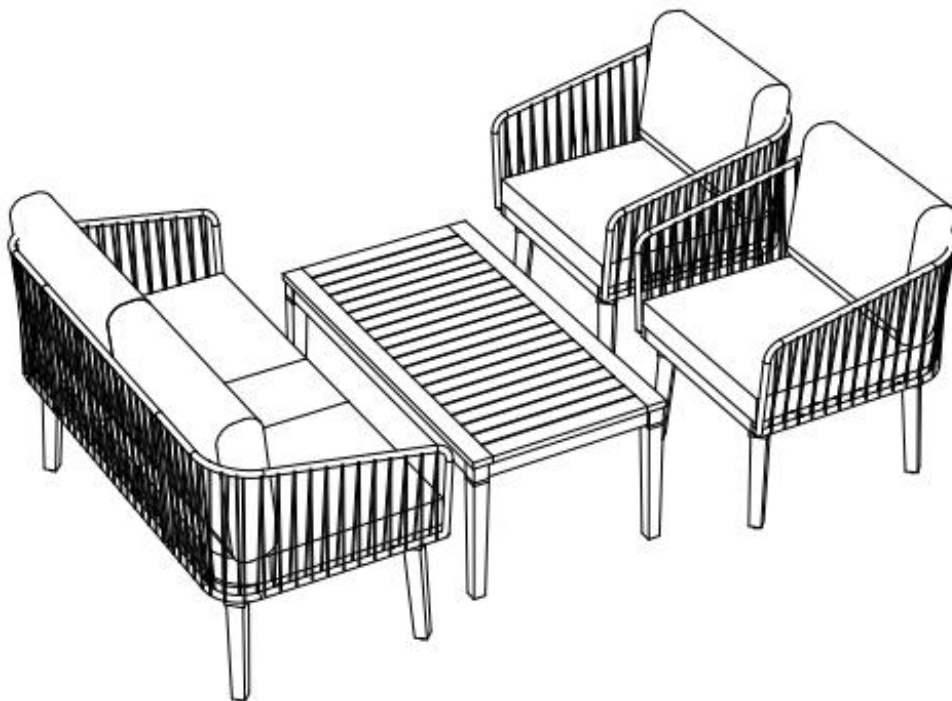

OPTION 2

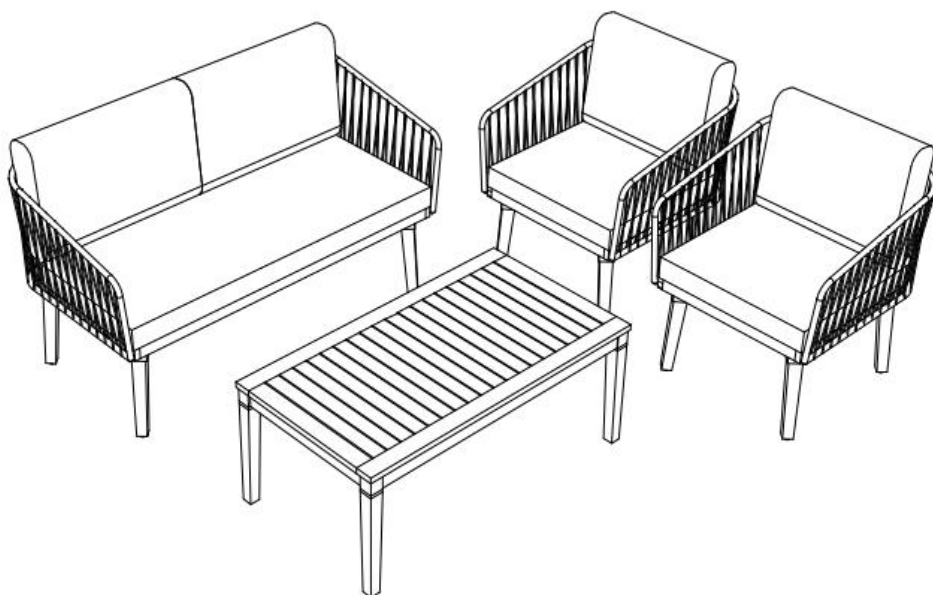

OPTION 3

Finish Patio Conversation Set