

ASSEMBLY INSTRUCTIONS

COUNTER HEIGHT TABLE

Thank you for purchasing this quality product. Be sure to check all packing material carefully for small parts that may have come loose inside the carton during shipment.

Key Parts		
No	Qty	Description
1	1 pc	Table top
2	4 pcs	Leg
3	4 pcs	Floor Leveler

Hardware kit		
No	Descri	Qty
A	 Flat washer	8 pcs
B	 Lock washer	8 pcs
C	 Bolt 8x30 mm	8 pcs
D	 Key wrench	1 pc

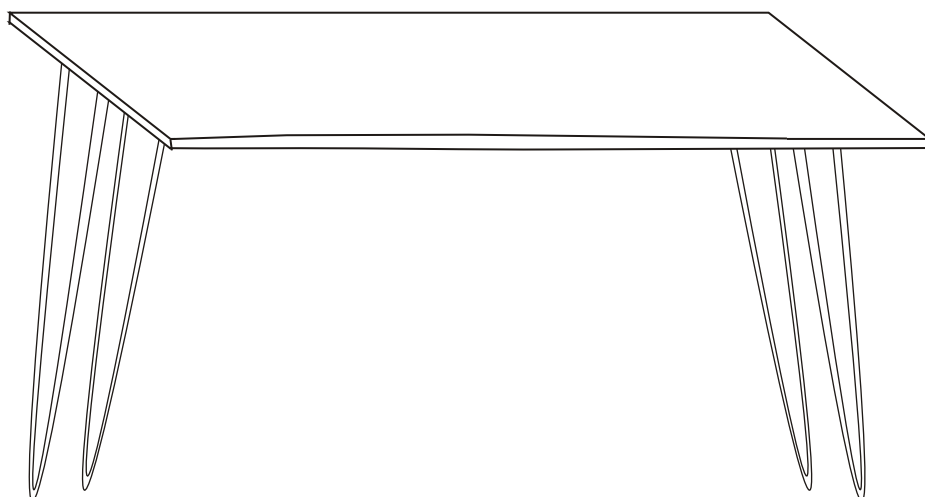
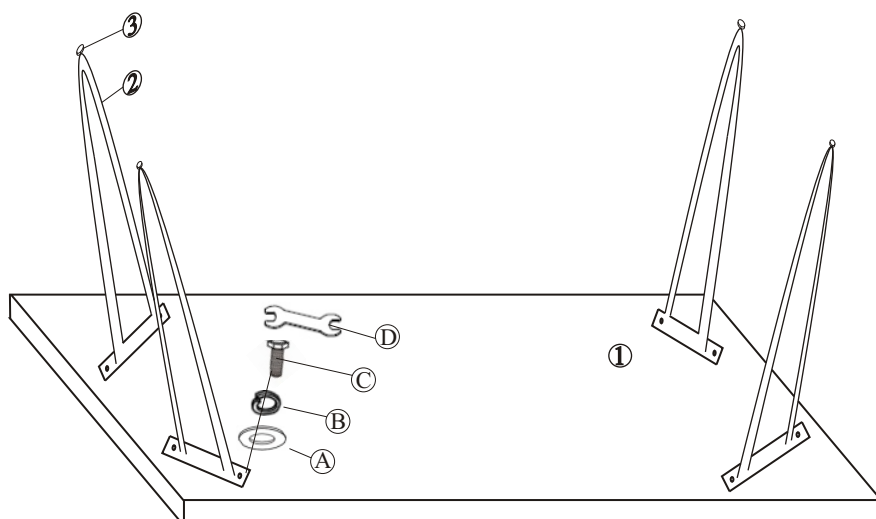

ASSEMBLY INSTRUCTIONS

GREY

Hardware kit

Ltr	Qty	Description
A	9PCS.	BOLT ØM6X16MM
B	4PCS.	BOLT ØM6X28MM
C	4PCS.	FLAT WASHER
D	1PC	ALLEN WRENCH
E	4PCS.	BOLT ØM6X20MM

Parts Key

No	Qty	Description
1	1PC	LEG ASSEMBLY
2	1PC	BACK FRAME
3	1PC	FOOTREST
4	1PC	BACK CUSHION
5	1PC	SEAT CUSHION
6	4PC	LEVELER

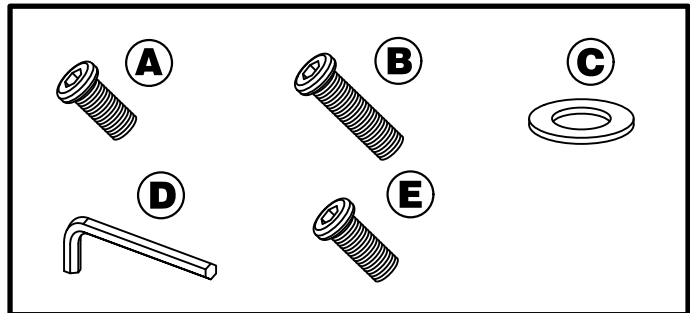

STEP 1:

- . Attach the leg assembly to the seat by inserting a flat washer and short bolt A per the diagram.
- . Attach the backrest frame to the seat by inserting short bolt A per the diagram.
- . Attach the footrest to the leg by inserting medium bolt E per the diagram.
- . Do not fully tighten at this point.

STEP 1:

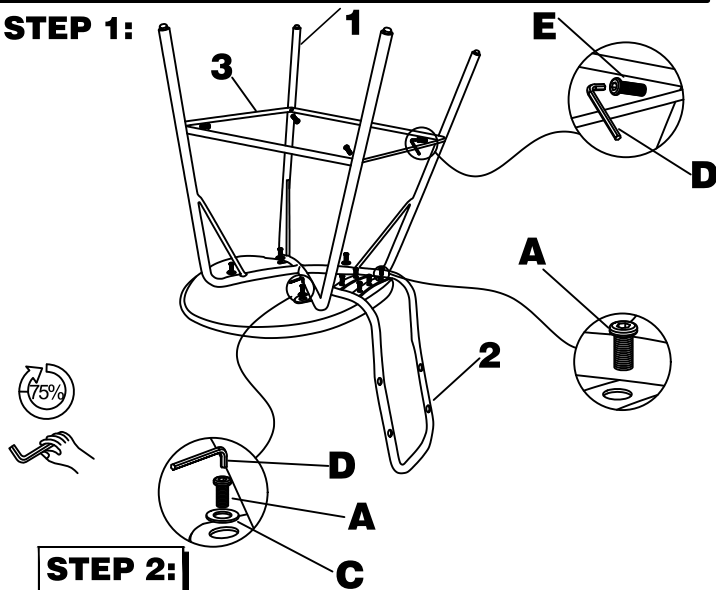

STEP 2:

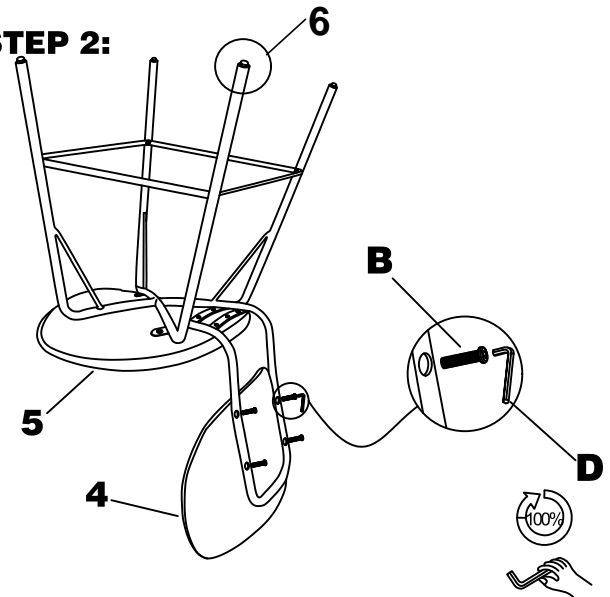

STEP 2:

- . Attach the backrest to the backrest frame by inserting long bolt B per the diagram.
- . Do not fully tighten the bolts until all are in place.
- . Once all bolts are in place, fully tighten the bolts by hand using the provided Allen Wrench. DO NOT use a power tool to tighten.
- . Use the floor levelers to level the chair, if needed.

*** FABRIC CARE:

Avoid direct sunlight, water, oil, acid, sharp objects etc.
 Use vacuum cleaner to clean. Wipe spills immediately.
 If needed, spot clean with a mild water-based soap.
 Fabric content 100% Polyurethane, Cleaning Code W

