

INSTRUCTION MANUAL

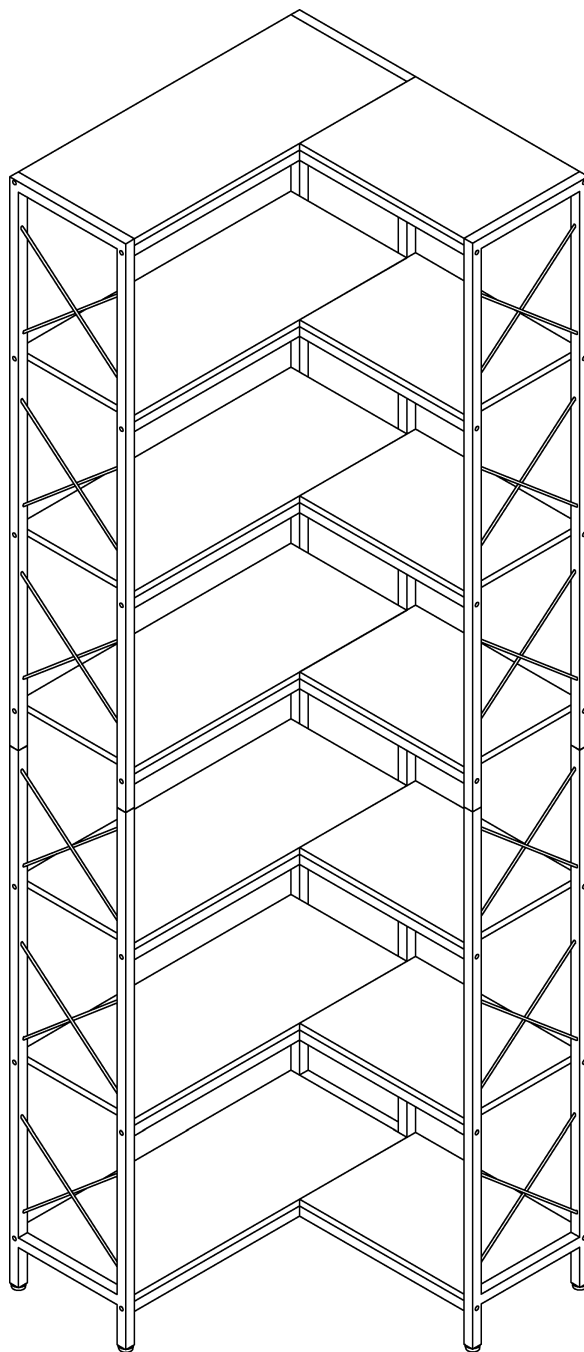

■ Please don't tighten the screws completely and go back later for a final tightening of all the screws after pieces are aligned with each other.

■ If you have any question, please feel free to contact us.



MADE IN CHINA

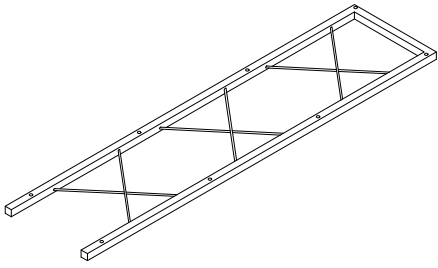

① x2PCS

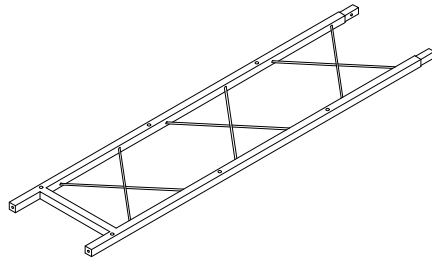

② x2PCS

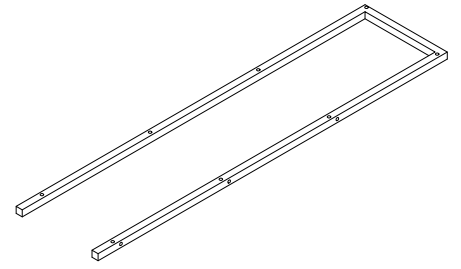

③ x1PC

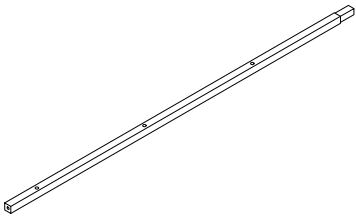

④ x1PC

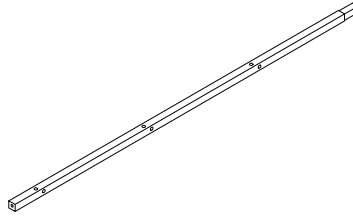

⑤ x1PC

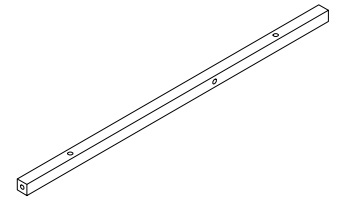

⑥ x7PCS

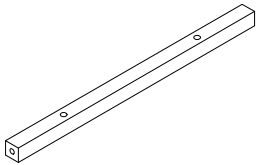

⑦ x7PCS

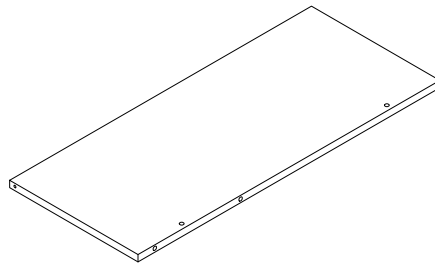

⑧ x6PC

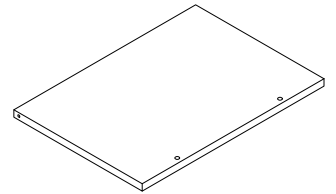

⑨ x6PCS

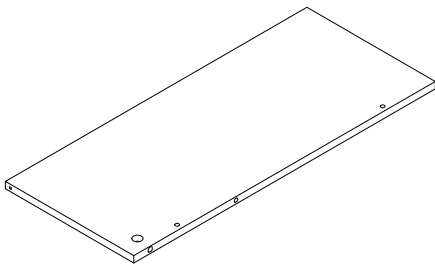

⑩ x1PC

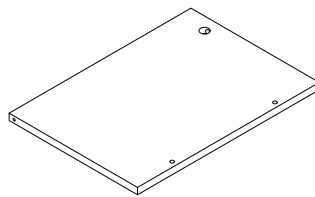

⑪ x1PC

LIST PART A

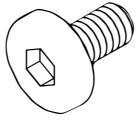

M6*12mm
A x 6PCS

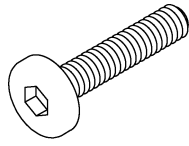

M6*25mm
B x 56PCS

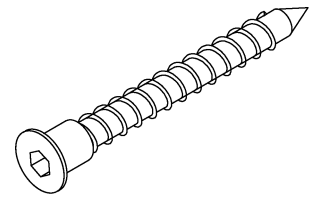

M5*45mm
C x 27PCS

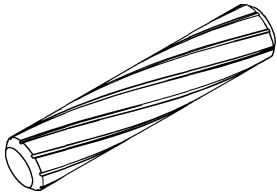

D x 13PCS

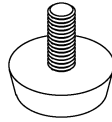

E x 6PC

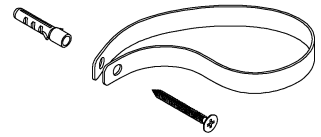

F x 2PCS

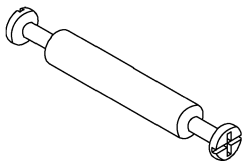

G x 1PC



H x 2PCS

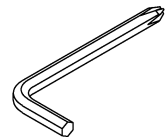

I x 1PC

1

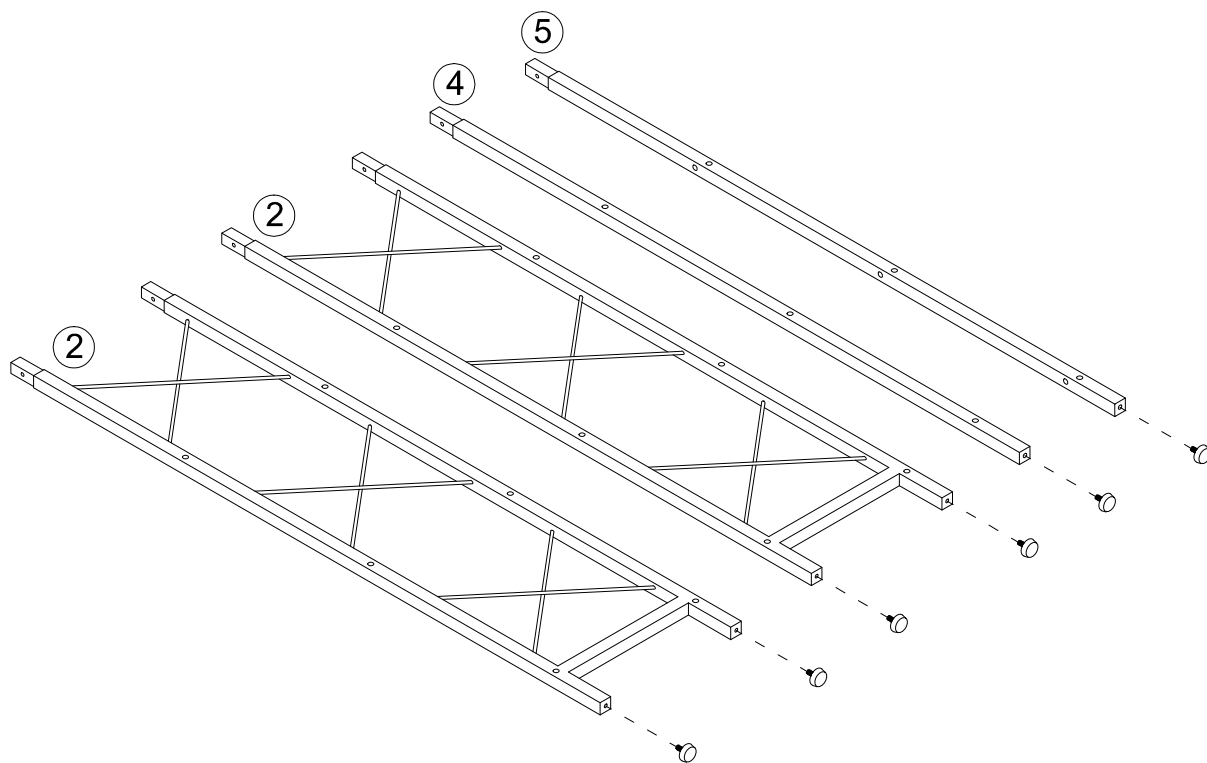

②		2PCS
④		1PC
⑤		1PC
E		6PCS

2

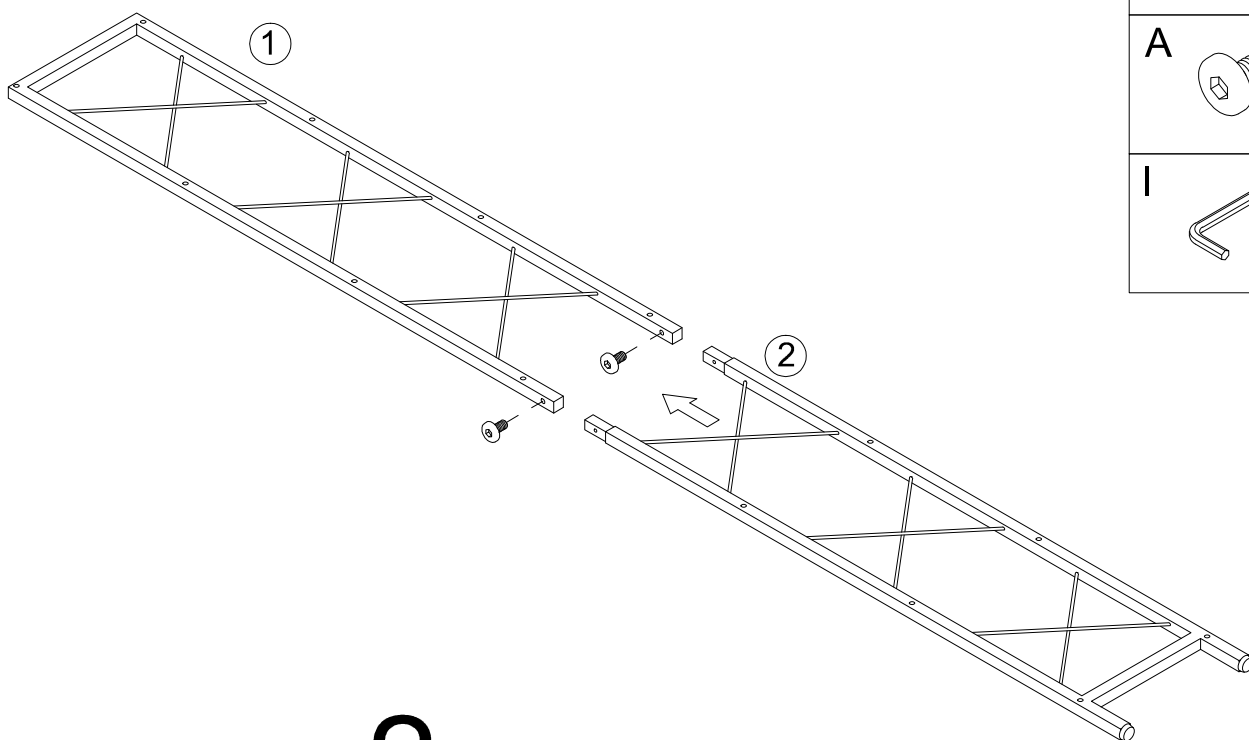

①		2PCS
A		4PCS
I		1PC

x 2

3

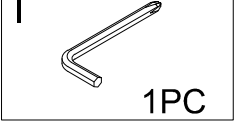
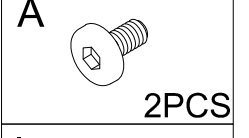
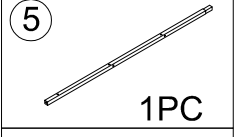
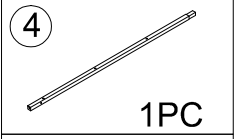
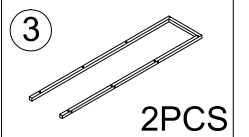
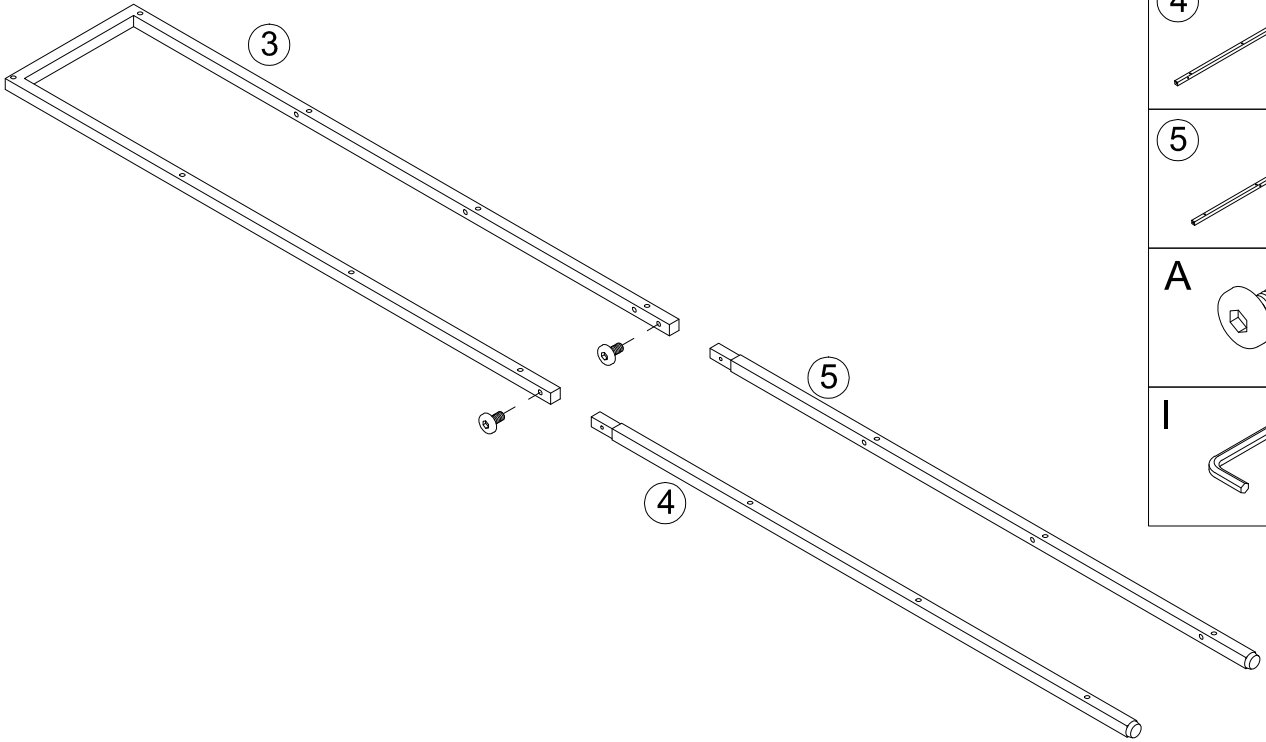

4

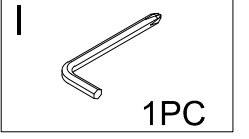
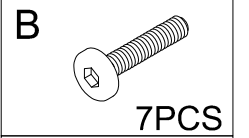
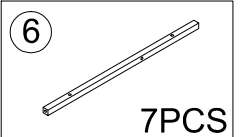
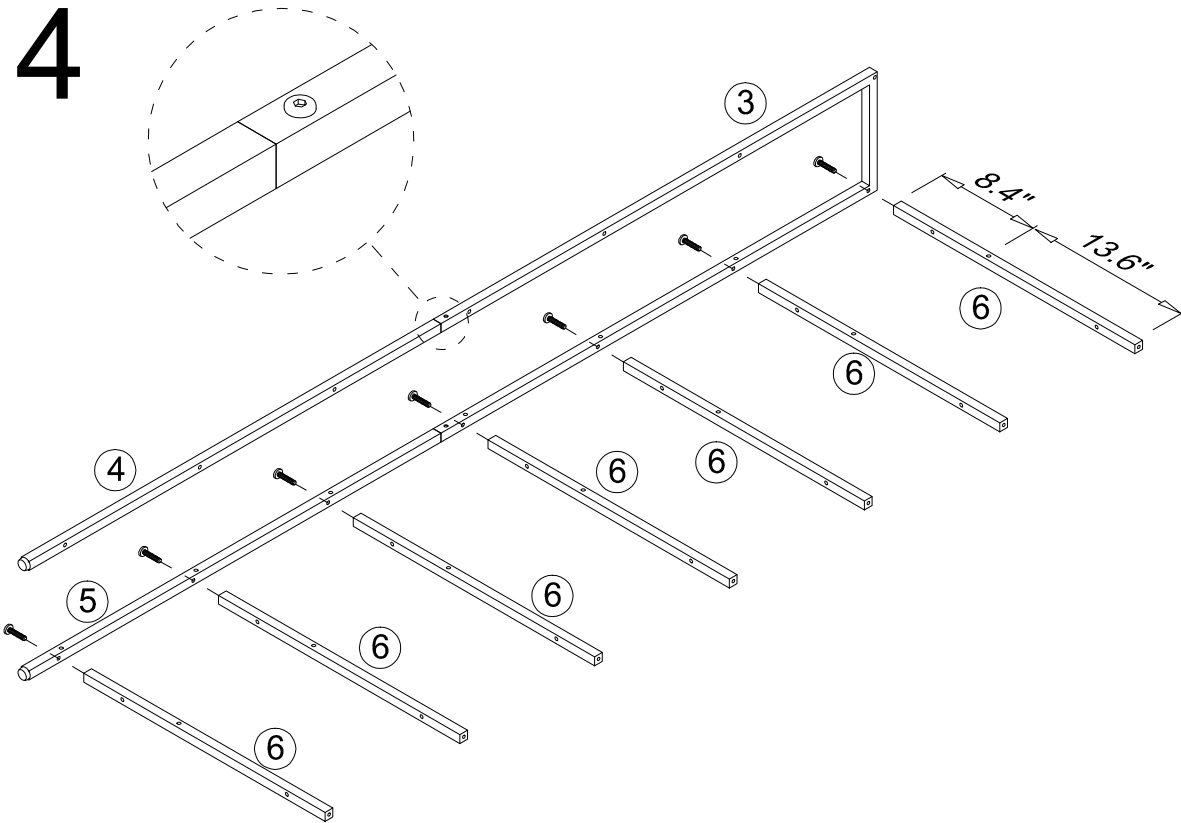

5

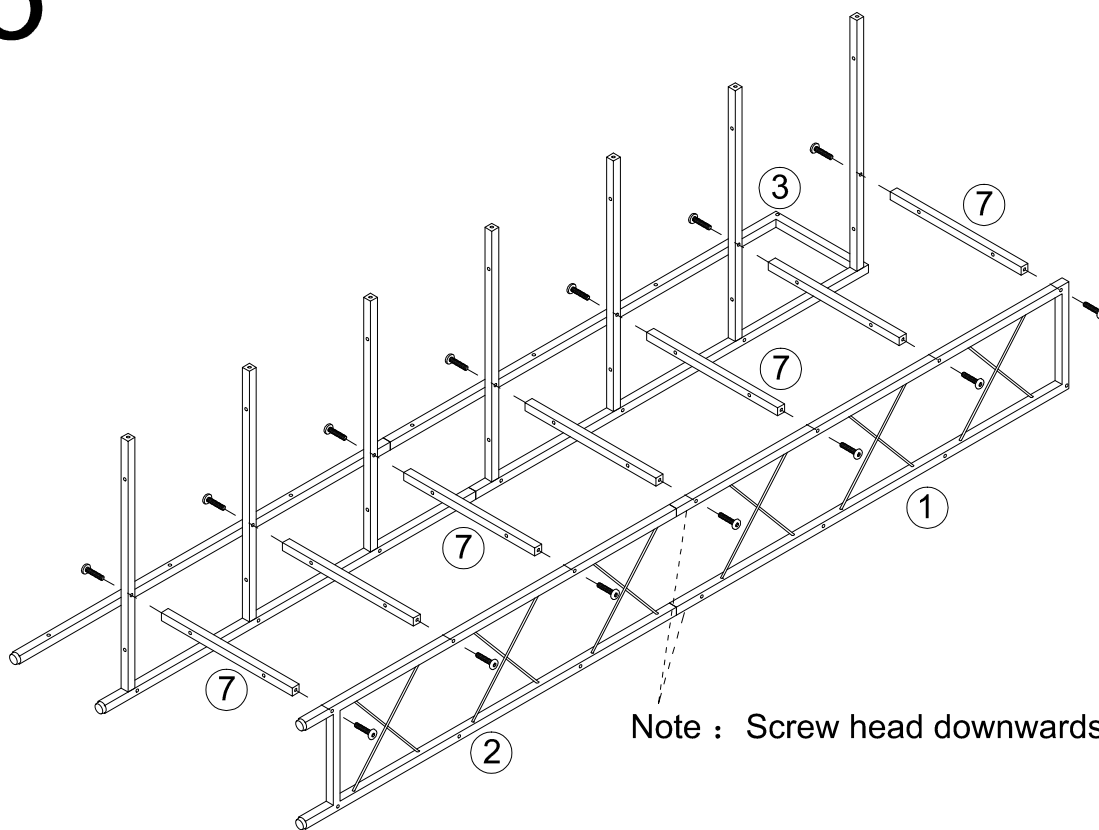
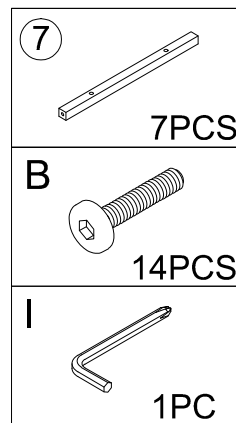

6

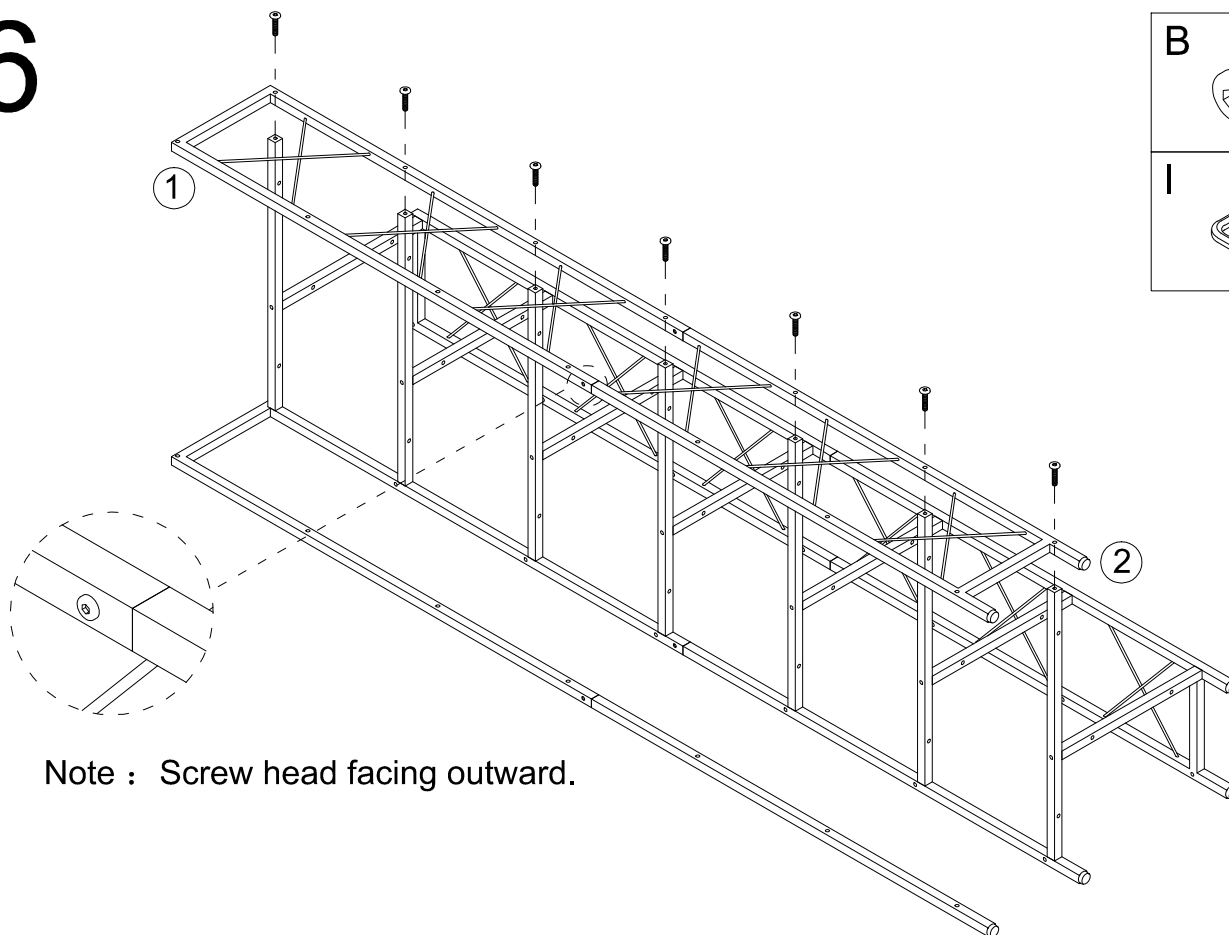
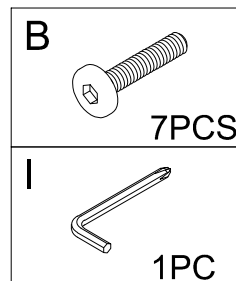

7

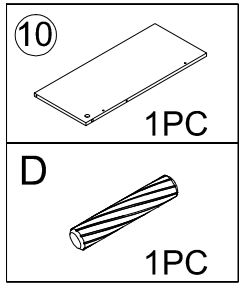
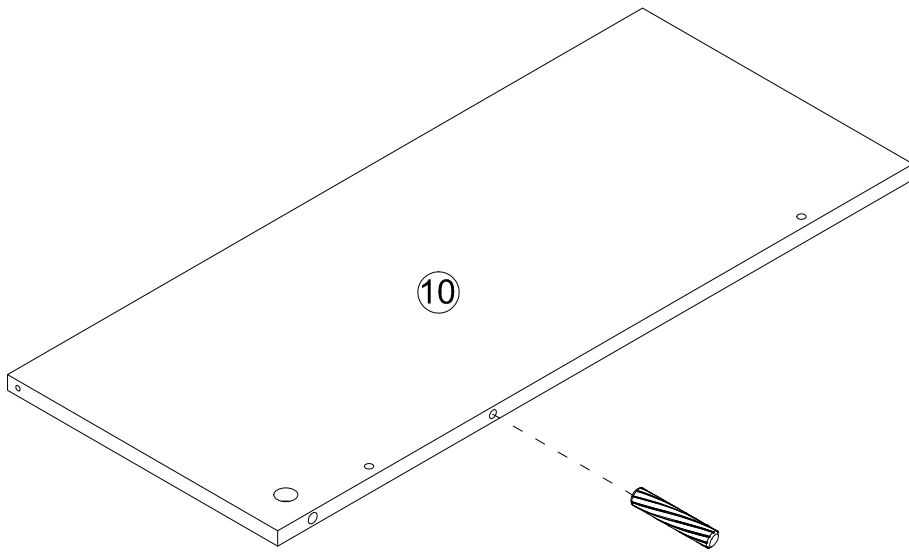

8

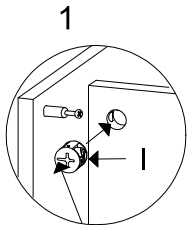

The arrow must point toward the edge of the board.

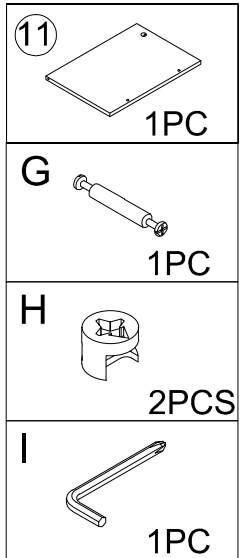
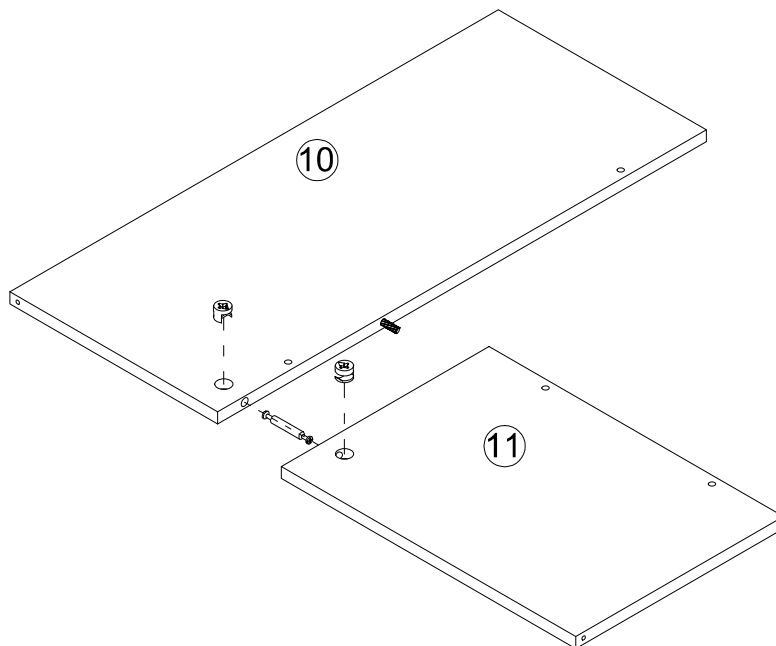
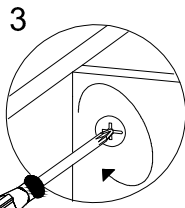
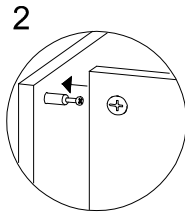

9

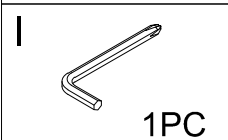
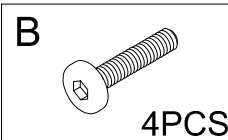
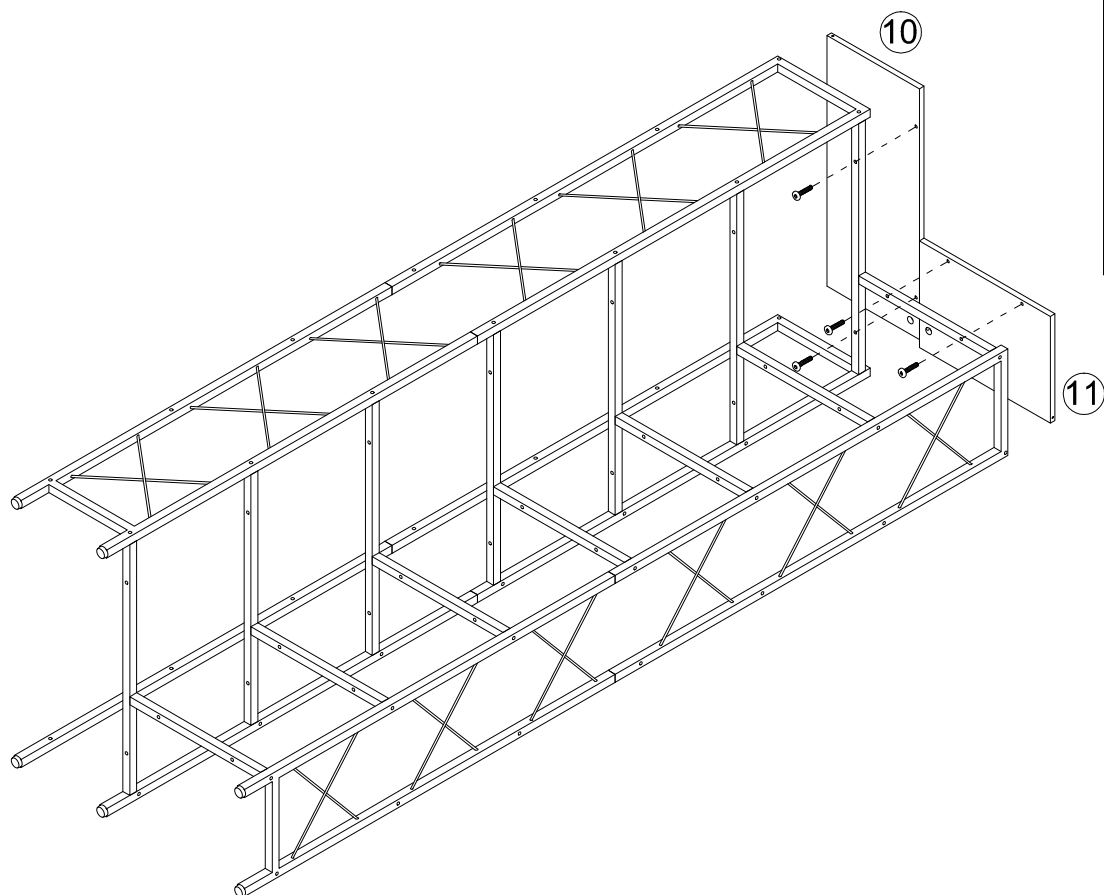

10

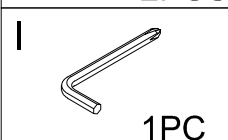
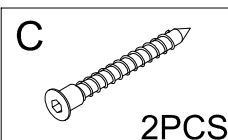
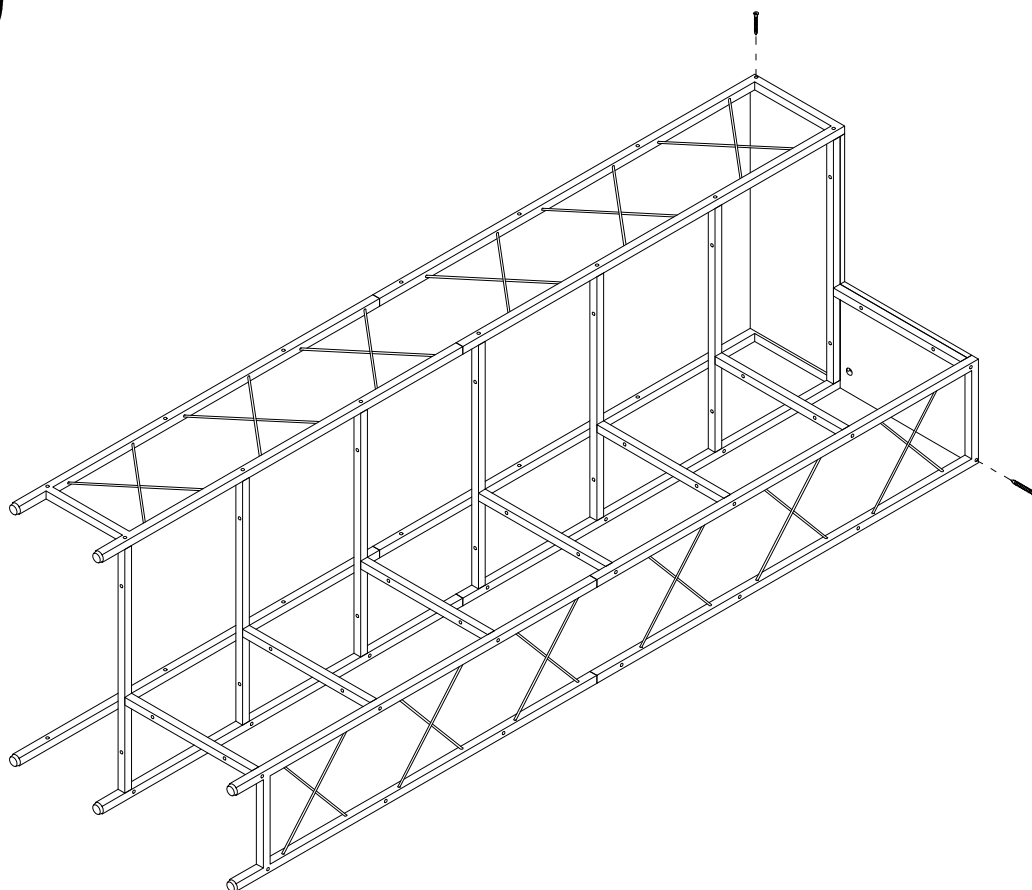

11

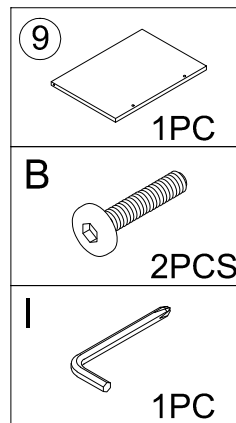
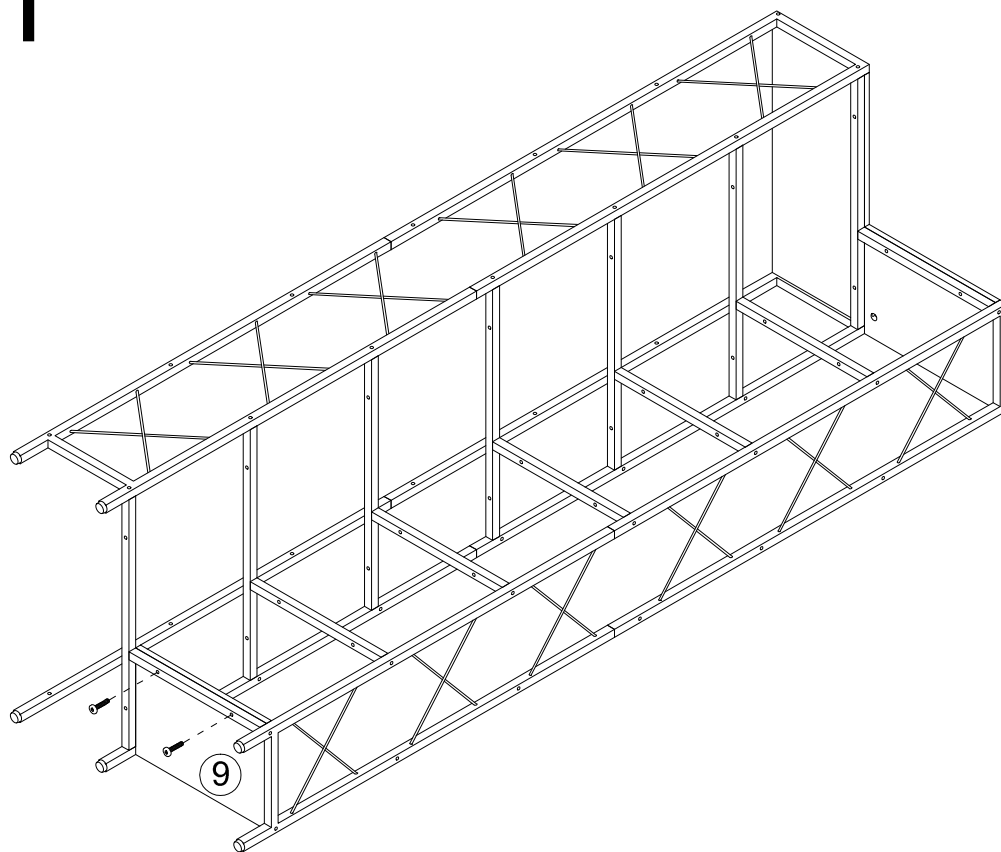

12

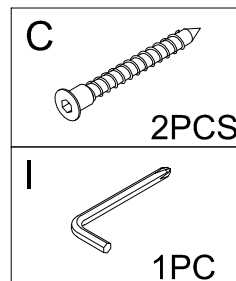
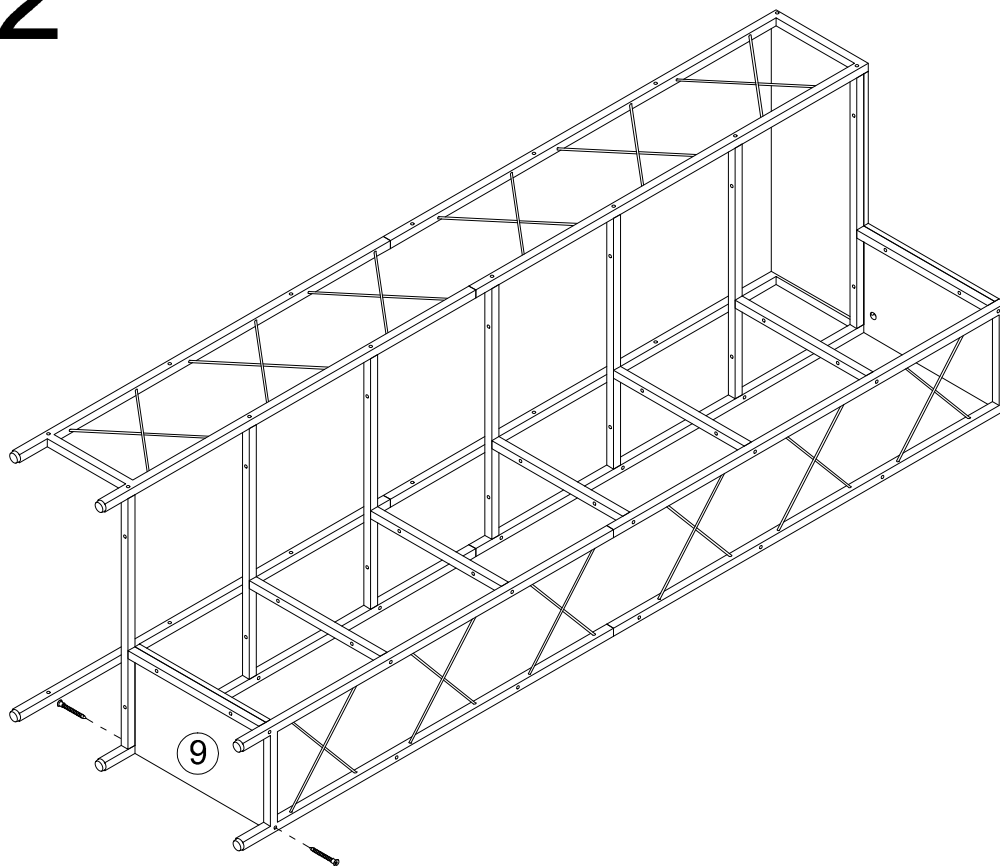

13

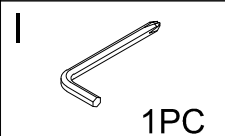
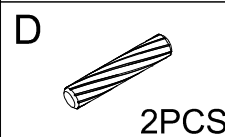
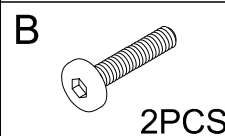
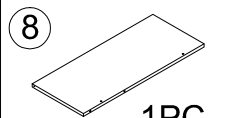
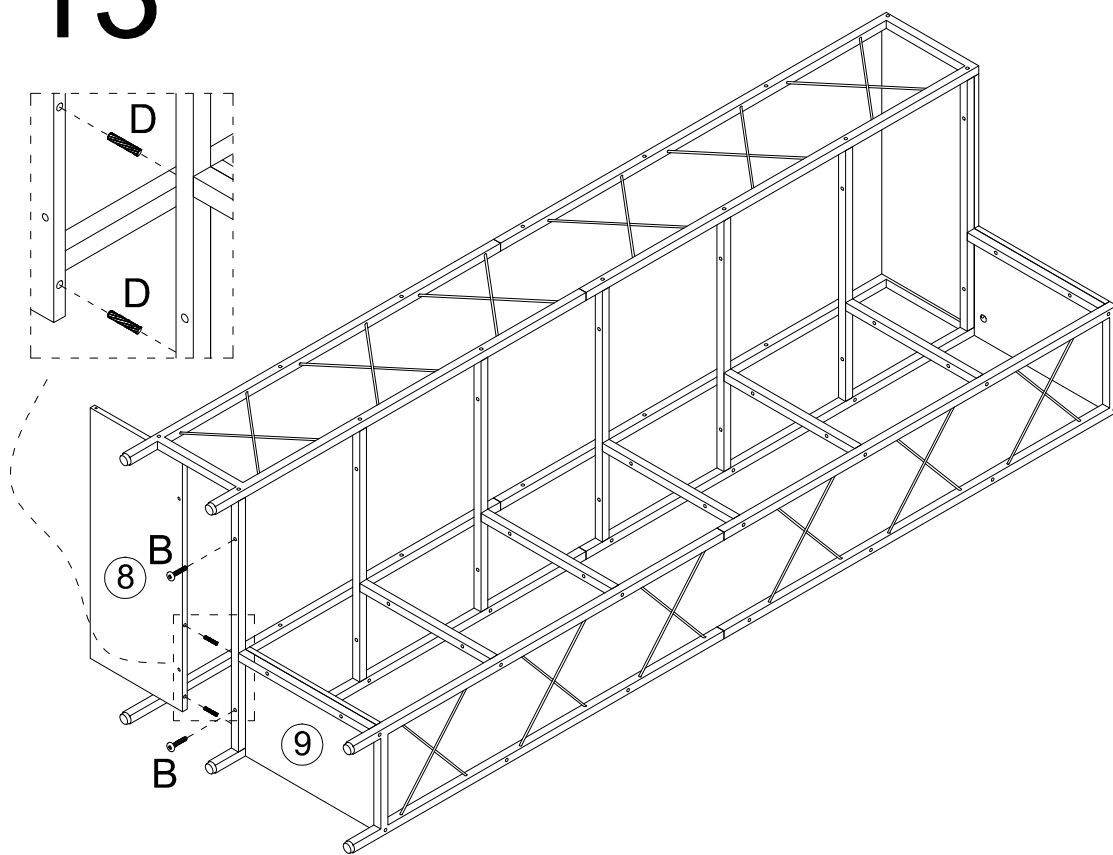
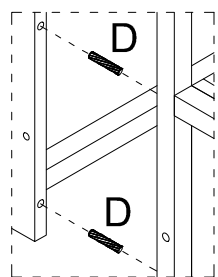

14

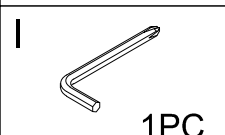
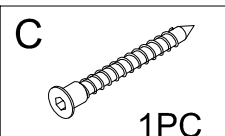
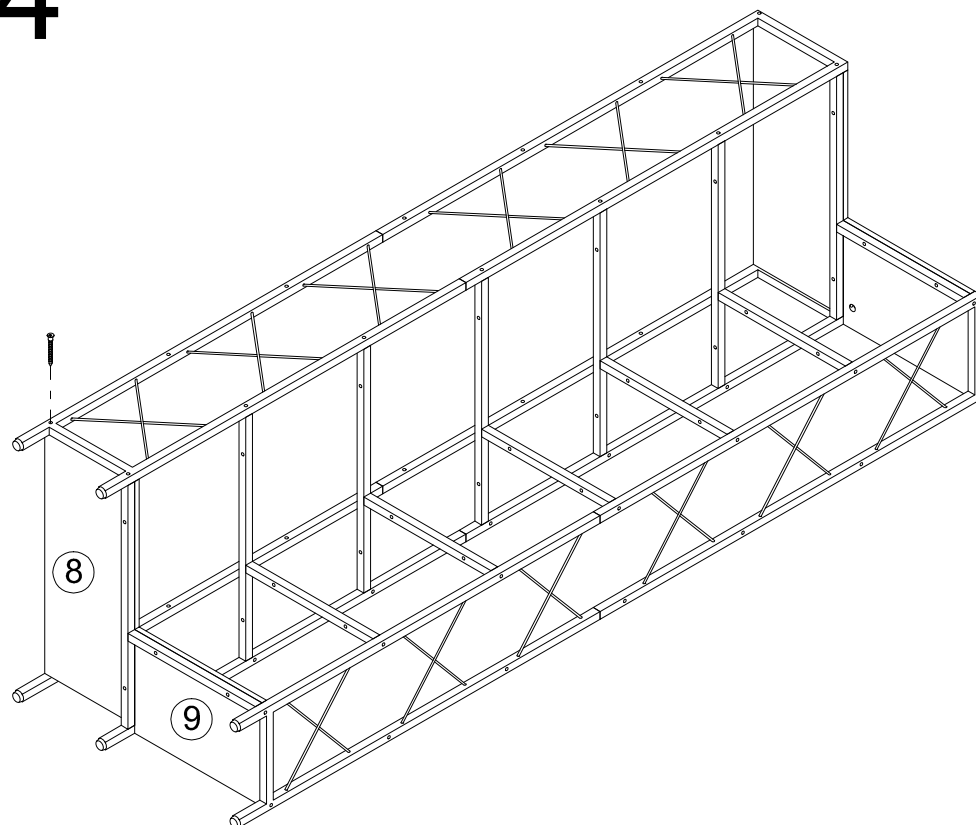

15

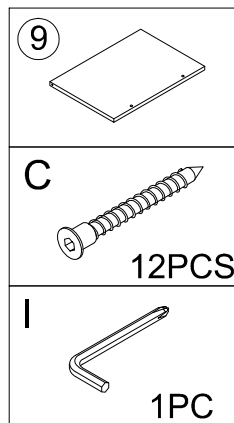
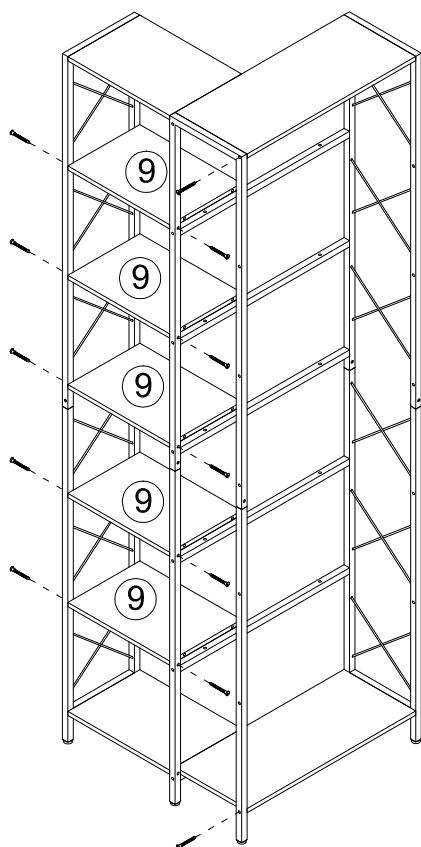

16

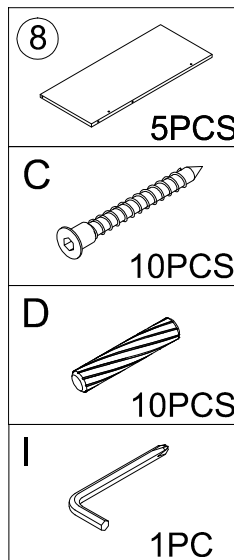
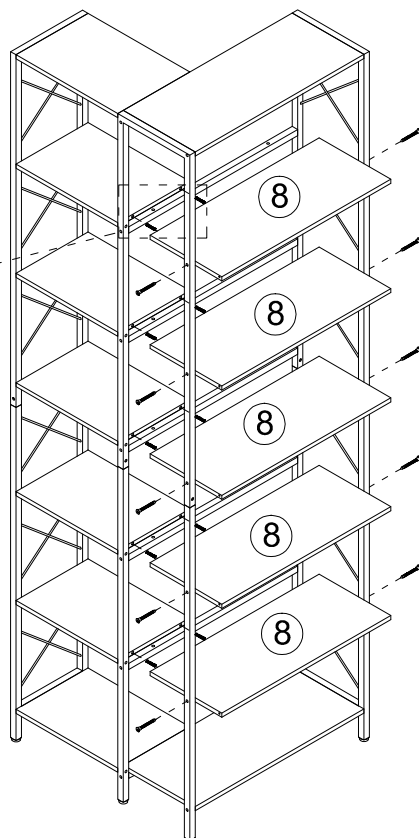
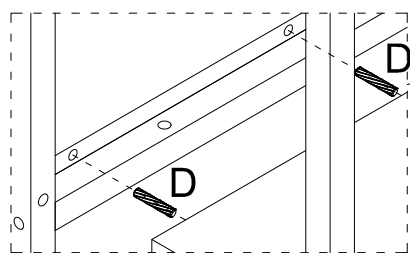

17

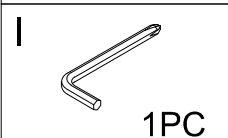
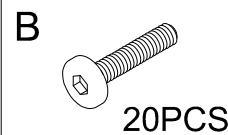
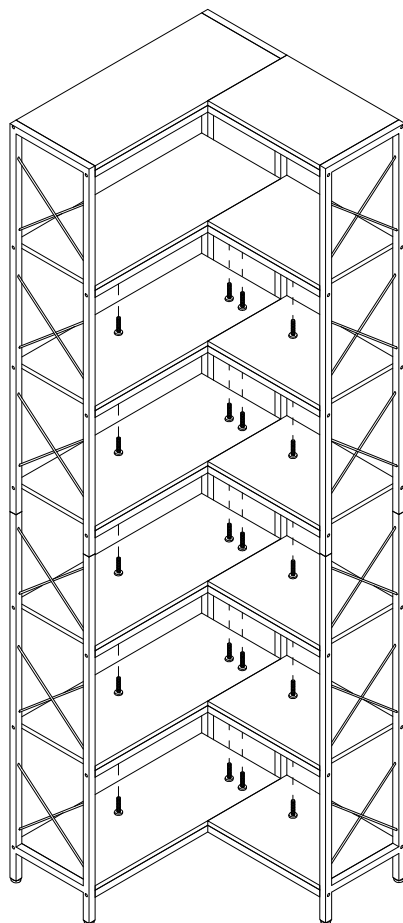

18

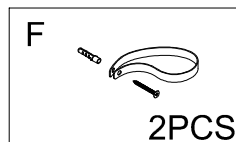
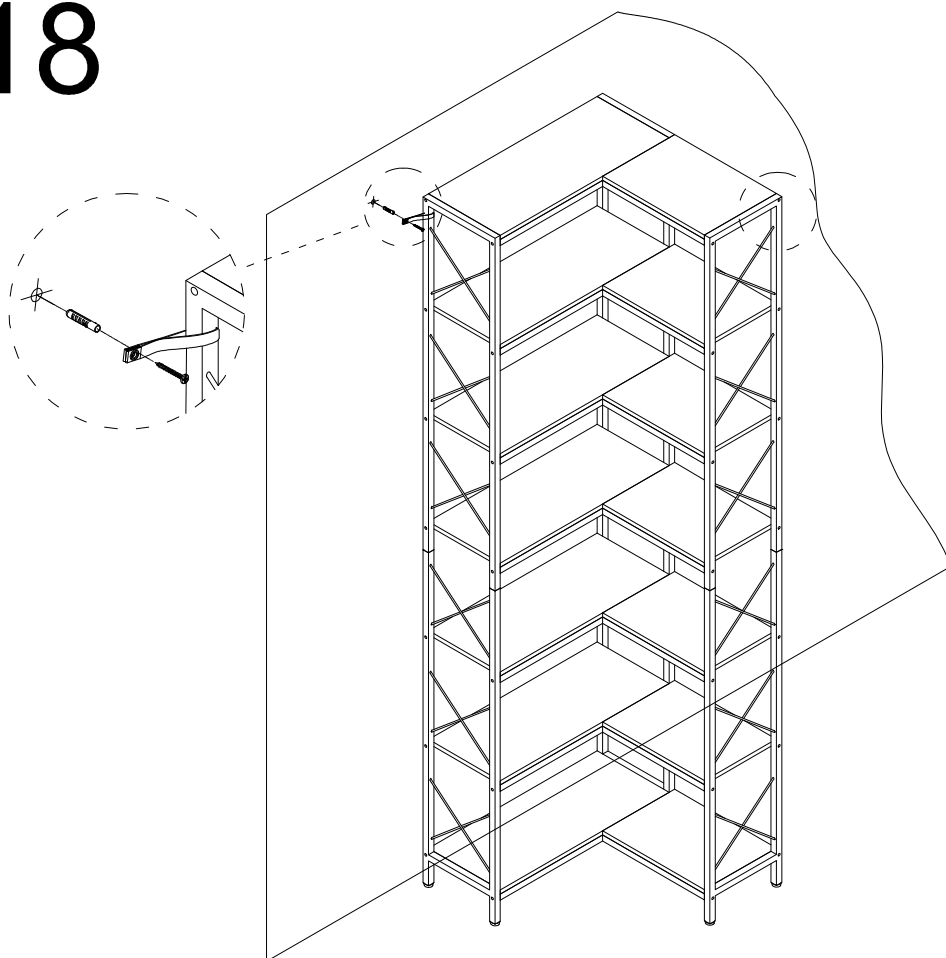

P12