

Please scan this QR code
to visit the product page

ELECTRIC STANDING DESK BASE WITH SINGLE MOTOR



HAVE QUESTIONS?

Monday - Friday from 8:00am - 4:00pm PST



support@mount-it.com















(855) 925-5668









www.mount-it.com

Thank you for choosing Mount-It!

- EN**  Read the entire instruction manual before you start installation and assembly. If you have any questions regarding any of the instructions or warnings, please contact Mount-It! for assistance.
-  **CAUTION:** Use with products heavier than the rated weights indicated may result in instability causing possible injury.
- Please closely follow the assembly instructions. Improper installation may result in damage or serious personal injury.
 - This product contains small items that could be a choking hazard if swallowed. Keep these items away from children.
- IMPORTANT:** Ensure that you have received all parts according to the component checklist prior to installation. If any parts are missing or faulty, contact Mount-It! for a replacement.
- MAINTENANCE:** Check that the product is secure and safe to use at regular intervals (at least every three months).
-
- DE**  Lesen Sie die gesamte Bedienungsanleitung, bevor Sie mit der Installation und Montage beginnen. Wenn Sie Fragen zur Anleitung oder Warnungen haben, wenden Sie sich bitte an Ihren örtlichen Händler.
-  **VORSICHT:** Die Verwendung mit Produkten, die schwerer als die angegebenen Nenngewichte sind, kann zu Instabilität führen und zu möglichen Verletzungen führen.
- Bitte befolgen Sie die Montageanleitung genau. Eine unsachgemäße Installation kann zu Schäden oder schweren Verletzungen führen.
 - Dieses Produkt enthält Kleinteile, die beim Verschlucken eine Erstickungsgefahr darstellen können. Halten Sie diese Gegenstände von Kindern fern.
- WICHTIG:** Stellen Sie vor der Installation sicher, dass Sie alle Teile gemäß der Komponenten-Checkliste erhalten haben. Bei beschädigten oder fehlenden Teilen, wenden Sie sich an Ihre Verkaufsstelle, um Ersatz zu erhalten.
- WARTUNG:** Überprüfen Sie das Produkt in regelmäßigen Abständen auf Sicherheit und Stabilität (am besten alle drei Monate).
-
- FR**  Lisez entièrement le guide d'utilisateur avant de commencer l'installation et le montage. Si vous avez des questions concernant les instructions ou les avertissements, veuillez contacter votre distributeur local pour une assistance.
-  **ATTENTION:** L'utilisation de produits plus lourds que les poids nominaux indiqués peut entraîner une instabilité causant des blessures potentielles.
- Les supports doivent être joints comme spécifié dans les instructions de montage. Une mauvaise installation peut entraîner des dommages ou de graves blessures aux personnes.
 - Ce produit contient de petites pièces qui peuvent causer un étouffement si elles sont avalées. Éloignez ces pièces des enfants.
- IMPORTANT:** Avant l'installation, assurez-vous que vous avez reçu toutes les pièces selon la liste de vérification des composants. Si une pièce est manquante ou endommagée, téléphonez à votre distributeur local pour qu'il la remplace.
- MAINTENANCE:** A intervalles réguliers (au moins tous les trois mois) vérifiez que le support est d'utilisation sûre et fiable.
-
- RU**  Перед началом установки и сборки прочитайте руководство по установке. Если у Вас возникли какие-либо вопросы относительно инструкций или предупреждений, свяжитесь с Вашим локальным распространителем для получения помощи.
-  **Внимание:** Использование продуктов, вес которых превышает указанный расчетный вес, может привести к неустойчивости и возможным травмам.
- Опоры должны быть установлены, как это показано в Монтажных инструкциях. Неправильная установка может привести к получению серьезных травм.
 - Данный продукт содержит маленькие детали, которые представляют опасность удушья при проглатывании. Такие детали необходимо хранить в недоступном для детей месте.
- ВАЖНО:** Перед установкой убедитесь, что Вы получили все детали в соответствии со списком комплектующих. Если не хватает каких-либо деталей или они поломаны, свяжитесь с Вашим местным распространителем по вопросу замены.
- ТЕХНИЧЕСКОЕ ОБСЛУЖИВАНИЕ:** Необходимо регулярно проверять (как минимум, раз в три месяца), чтобы кронштейн был зафиксирован, и его использование было безопасным.
-
- ES**  Lea todo el manual de instrucciones antes de comenzar la instalación y ensamble de la unidad. Si tiene alguna inquietud con respecto a las instrucciones o advertencias, comuníquese con su distribuidor local.
-  **PRECAUCION:** utilizar con productos de mayor peso al indicado en los límites de peso podría ocasionar inestabilidad y posibles heridas personales.
- Los soportes deben acoplarse tal como se indica en las instrucciones de ensamble. Una incorrecta instalación podría ocasionar daños y serias heridas personales.
 - Este producto contiene piezas pequeñas que representan un riesgo de asfixia. Mantenga estas piezas fuera del alcance de los niños.
- IMPORTANTE:** Asegúrese de que haya recibido todas las piezas según la lista de verificación de componentes para la instalación. Si falta alguna de las partes, o está dañada, comuníquese con su distribuidor.
- MANTENIMIENTO:** Compruebe periódicamente que el soporte esté asegurado y listo para usar (al menos cada tres meses).
-
- PT**  Leia todo o manual de instruções antes de iniciar a instalação e montagem. Se você tiver alguma dúvida sobre quaisquer uma das instruções ou avisos, por favor, entre em contato com o seu distribuidor local para assistência.
-  **ATENÇÃO:** O uso com produtos mais pesados do que os pesos indicados pode resultar em instabilidade, causando possíveis danos.
- Os suportes devem ser anexados como especificado nas instruções de montagem. A instalação incorreta pode causar danos ou sérias lesões pessoais.
 - Este produto contém pequenas peças que podem causar asfixia se ingeridas. Mantenha esses itens longe do alcance de crianças.
- IMPORTANTE:** Assegure-se que você recebeu todas as peças, de acordo com a lista de componentes, antes da instalação. Se alguma peça estiver faltando ou é defeituosa, contate o seu distribuidor local para substituição.
- MANUTENÇÃO:** Certifique-se que o suporte seja seguro e protegido para o uso em intervalos regulares (pelo menos a cada três meses).

USING THE CONTROLLER

Please retain these instructions for future reference

	Short-press the [M] button, and the display will flash. Press the 1, 2, or 3 button to save the current height setting to that button.
	Press the [+] button to raise the desk continuously until it reaches the highest position of 46.4" (118cm) or the button is released.
	Press the [-] button to lower the desk continuously until it reaches the lowest position of 28.3" (72cm) or the button is released.
	Press the [1] button, and the desk will move to the height that was previously set for that button.
	Press the [2] button, and the desk will move to the height that was previously set for that button.
	Press the [3] button, and the desk will move to the height that was previously set for that button.
Settings	
Change Display Height Units	Press and hold the [M] button until a flashing 'S-' is displayed. Press [M] again, and 'Un' is displayed. Press [M] to select it, press [+] or [-] to switch between 'IN' (imperial) and 'SI' (metric), and press [M] to save your choice.
Change Collision Detection Sensitivity	Press and hold the [M] button until a flashing 'S-' is displayed. Press [M] again, and 'Un' is displayed. Press [+] or [-] to switch to 'CF' and press [M] to select it. Press [+] or [-] to switch between off, low, normal, and high sensitivity. Press [M] to save your choice.
Change Brightness	Press and hold the [M] button, until "S--" shows and flashes. Press [M] again and the display shows "Un". Press [+] or [-] to switch to "br". Press [M] to select. Press [+] or [-] to switch between Low (L), Normal (n) or High (H) brightness. Press [M] to save your choice.
Reset	Press and hold the [-] button for 5 seconds, and the screen will show 'RES.' Continue holding until the desk goes down to its lowest level and comes back up slightly.
Protection Mode Error Codes	
Hot	Overheating Protection: When the motor has been working continuously for 5 minutes, it will stop operating to prevent damage from overheating. Wait for at least 15 minutes before making any further height adjustment.
E10	Sensor Malfunction Warning: Motor safety sensor can't be detected. Power off, check the connection between the motor and controller, and power back on again.
E20	Overloading Warning: Max load exceeded. If raising the desk, take the things off the desk and try again. If lowering the desk, power off, take the things off the desk, power back on, and try again.
E02	Operation Status Warning: The desk stops moving if vibration, impact, or incline are detected. If this detection is incorrect, follow the reset instructions before continuing use.
E32	Overvoltage Protection: Input voltage too high. If the correct AC adapter is being used, power off the desk, check the connection between power and the controller, and power on again.
E31	Undervoltage Protection: Input voltage too low. If the correct AC adapter is being used, power off the desk, check the connection between power and the controller, and power on again.
-	Cable Disconnection Warning: Check motor and controller cable connections. Normal operation should return once all connectors are properly connected.

DESKTOP NOT INCLUDED

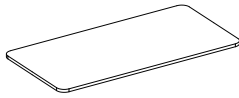

(x1)

SUGGESTED DESKTOP SIZE: 40"X22" - 63"X29.5"

HARDWARE CONTENTS



B (x1)
CONNECTOR

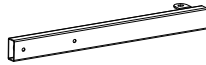

C (x1)
CROSSBAR



D (x1)
CROSSBAR



E (x2)
SIDE PLATE

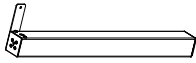

F (x1)
LEG

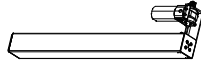

G (x1)
LEG WITH MOTOR

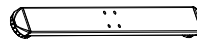

H (x2)
FEET



I (x1)
TRANSMISSION ROD

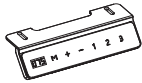

J (x1)
CONTROL PANEL



K (x1)
POWER ADAPTER

HARDWARE CONTENTS



L (x8)
M6x35 BOLT



M (x12)
M6x11 BOLT

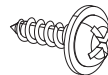

N (x10)
M5x16 SCREW



O (x2)
M4x12 SCREW



P (x1)
2mm
HEX WRENCH



Q (x1)
5mm
HEX WRENCH

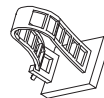

R (x2)
CABLE MANAGEMENT CLIP

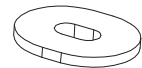

S (x10)
RUBBER PADS

EXTRA PARTS



L (x2)
M6x35 BOLT



M (x2)
M6x11 BOLT

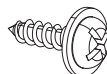

N (x2)
M5x16 SCREW



O (x1)
M4x12 SCREW



S (x2)
RUBBER PADS

Step 1

Assembling the Crossbar

On a flat and open section of the floor, position the Leg (#F) and Crossbar (#C) in the configuration shown here.

As shown in magnification bubble, using the Bolts (#M) tighten until secure using the 5mm Hex Wrench (#Q). Also assemble the Leg with Motor (#G) and Crossbar (#D).

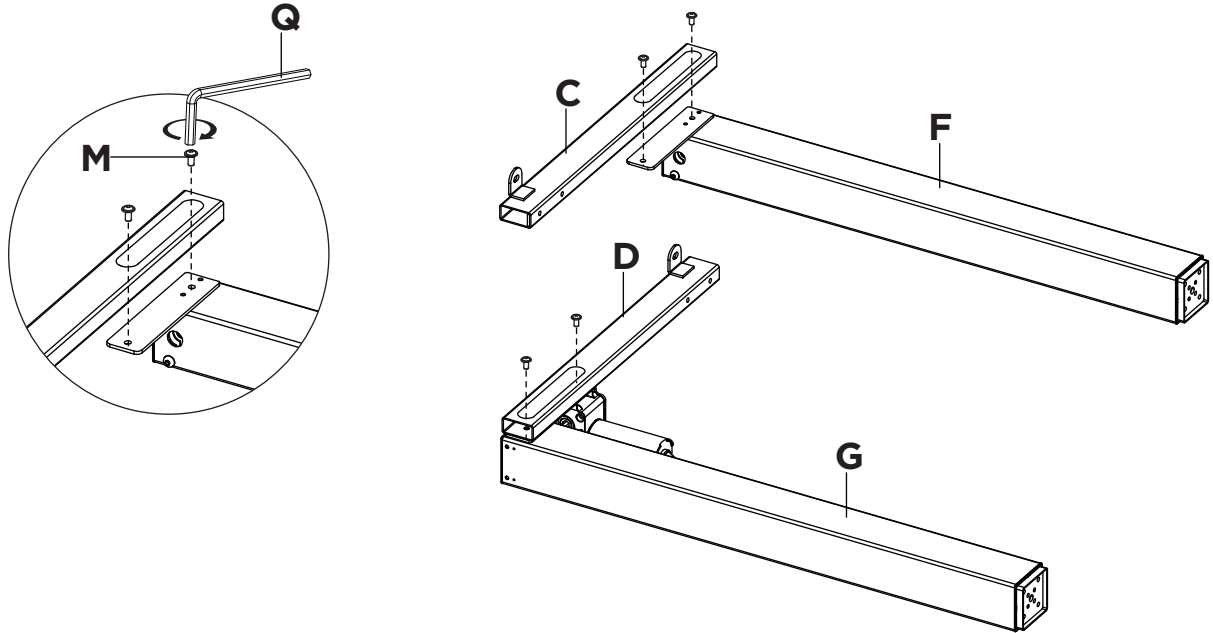

Step 2

Assembling the Side Plate

Attach the Side Plate (#E) to the Legs using Bolts (#M) and tighten until secure using the 5mm Hex Wrench (#Q). Ensure that the Side Plates are oriented as shown in the image.

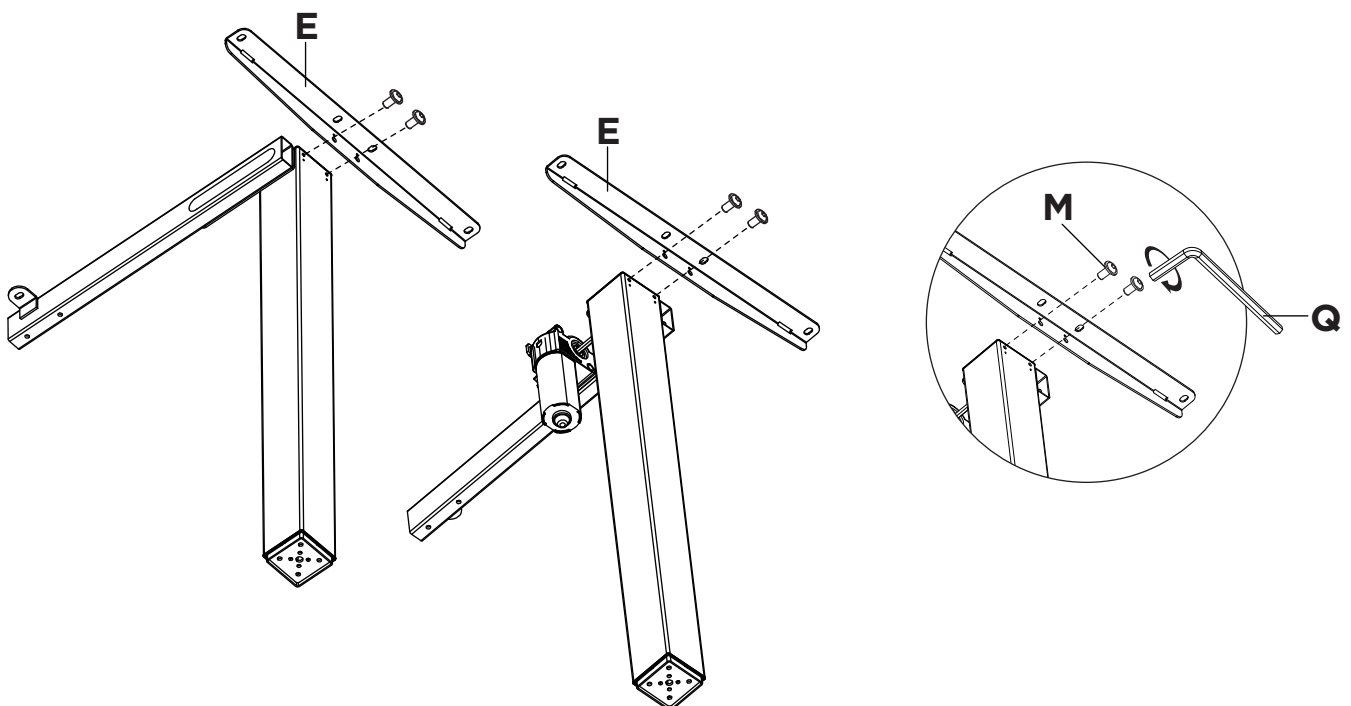

Step 3

Assembling the Feet

Attach the Feet (#H) to the Legs (#F & G), using Bolts (#L) and tighten until secure using the 5mm Hex Wrench (#Q).

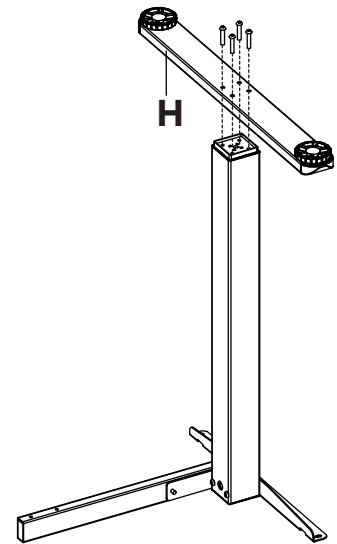
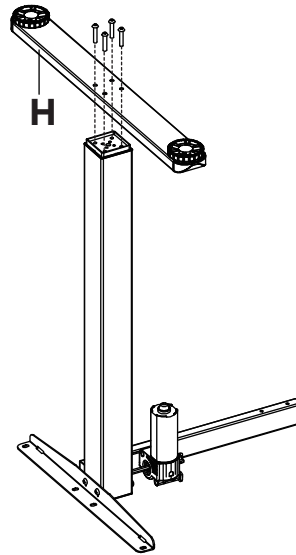
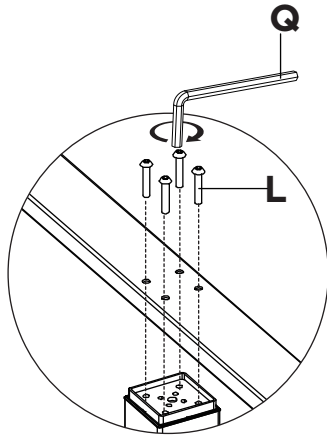

Step 4

Assembling the Connector

Insert the Connector (#B) into each end of the Crossbars as shown here.

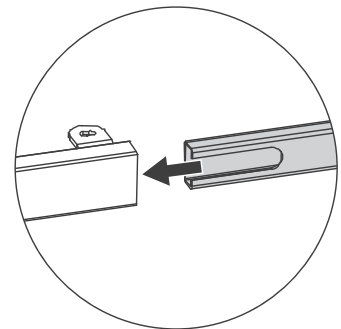
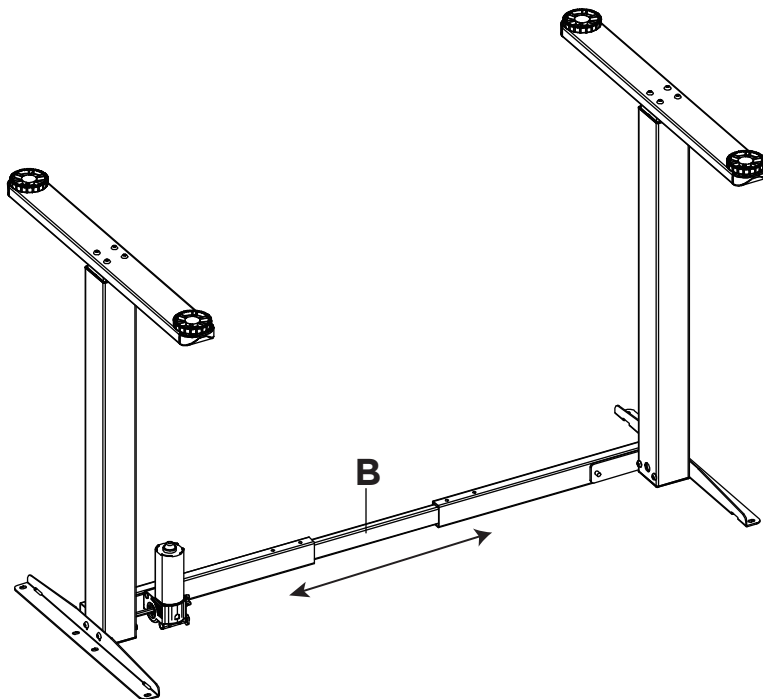

Step 5

Attaching the Transmission Rod

Setting the Desk Legs to the Same Height

Before attaching the transmission rod, measure the heights of the right and left desk legs to see if they are set at the same level. If not, the Leg (#F) without the motor will need to be adjusted to match the height of the other Leg with Motor (#G). Insert the transmission rod into the hole in the Leg (#F) and turn the rod by hand to bring it to the same level as the other. Turn the rod anti-clockwise to lower the leg, or clockwise to raise it.

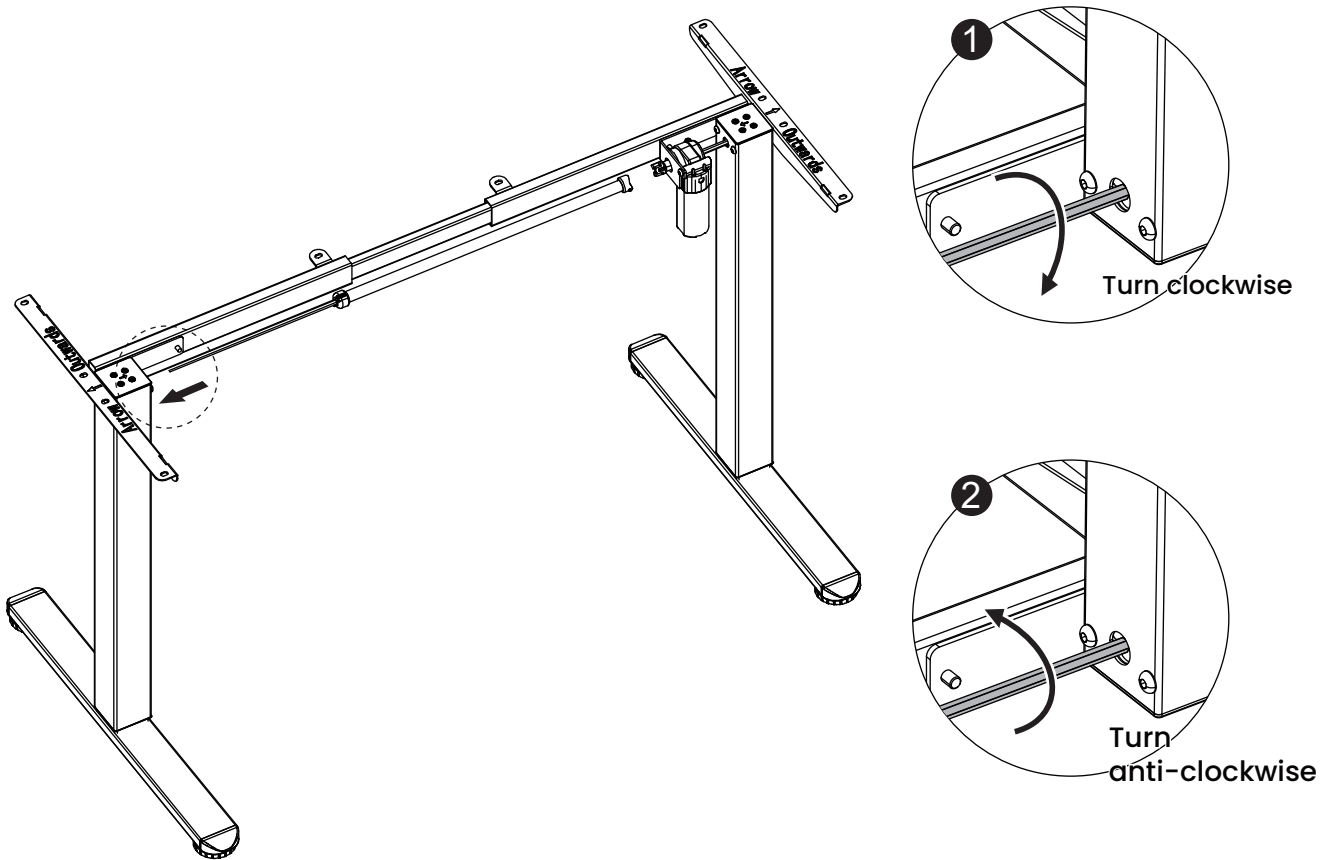
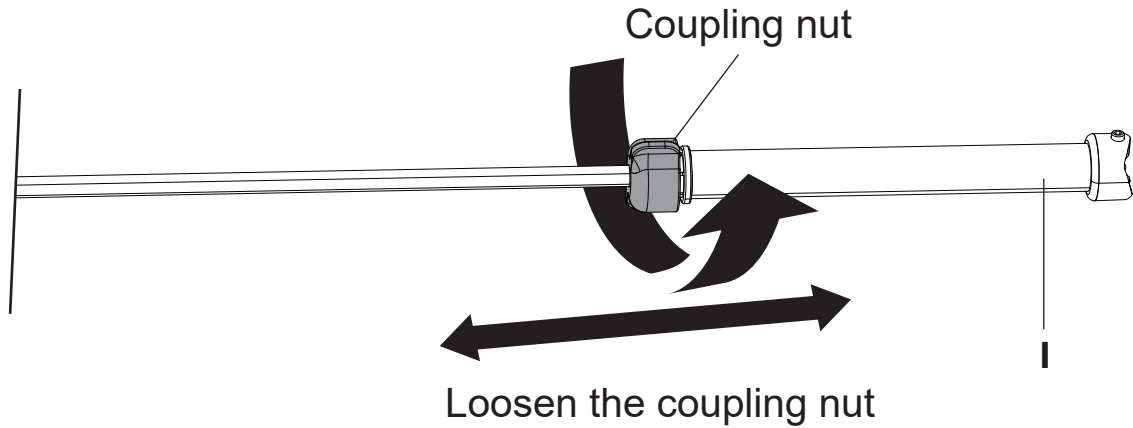

Ensure the transmission rod is properly inserted into the hole in the left leg.
Extend the rod to connect the other end to the motor drive shaft on the right desk leg.

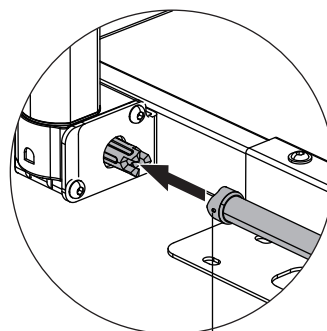
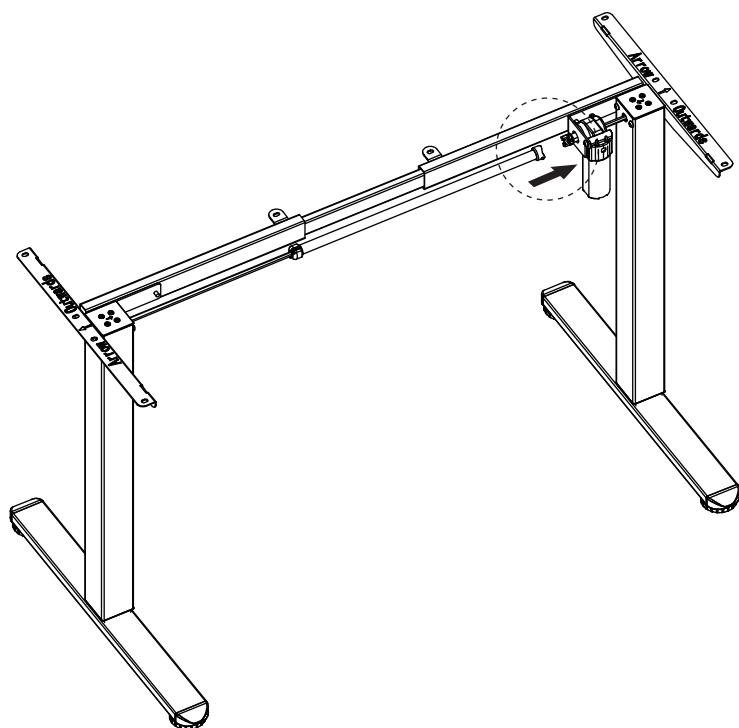

NOTE: Make sure the set screw faces out.

Secure the transmission rod to the motor drive shaft by turning the set screw clockwise.
Then tighten the coupling nut to fine-tune transmission rod fit.

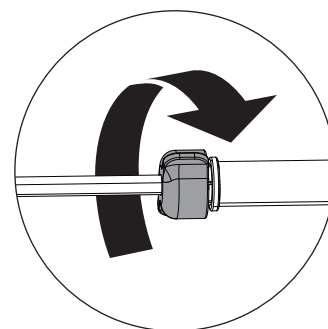
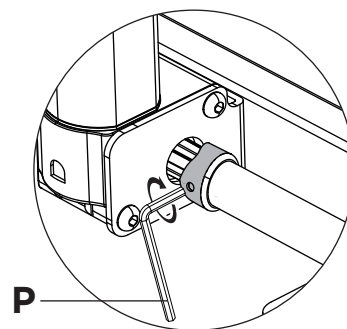
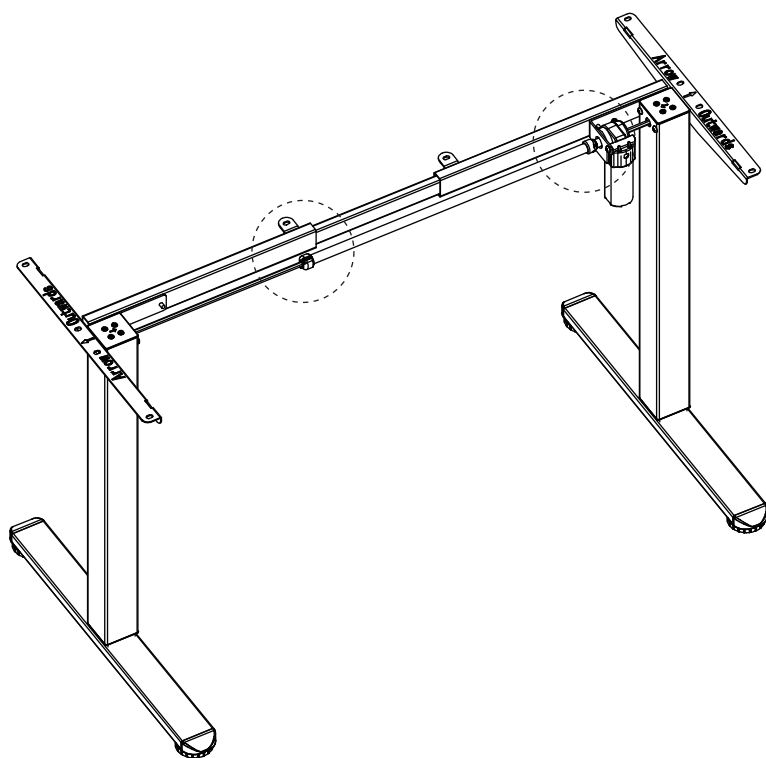

Coupling Nut

Step 6

Attach the Rubber Pads

Attach 10x Rubber Pads (#S) to the top of the frame in the locations shown here.

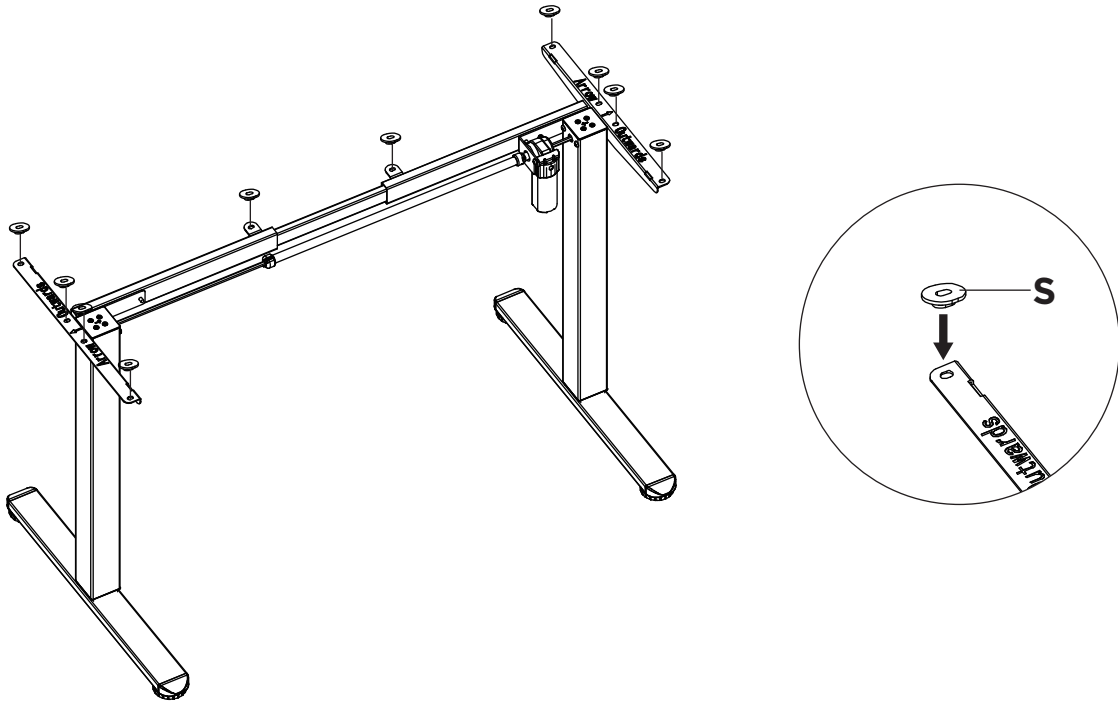

Step 7

Attaching the Frame to the Desktop

Turn the leg frame over and carefully place it upside down on the desktop. Adjust the width of the frame and rod until it is suitable for the desktop, then tighten the crossbars (#C, D) to connector (#B) using Bolts (#M) as shown in the magnification bubble, and tighten until secure using the 5mm Hex Wrench (#Q).

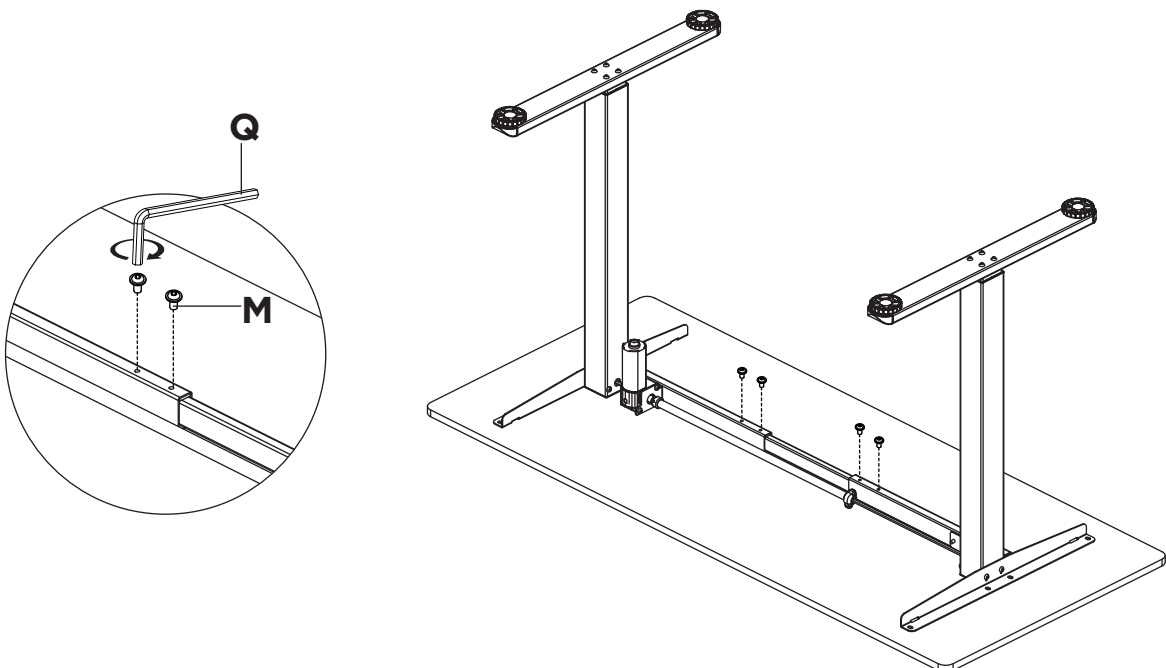

Step 8

Assembling the Desktop and Control Panel

Attach the Desk Frame to the Desktop using Screws (#N). Tighten until secure.
Using Screws (#J) attach the Control Panel (#J) to the locations shown.

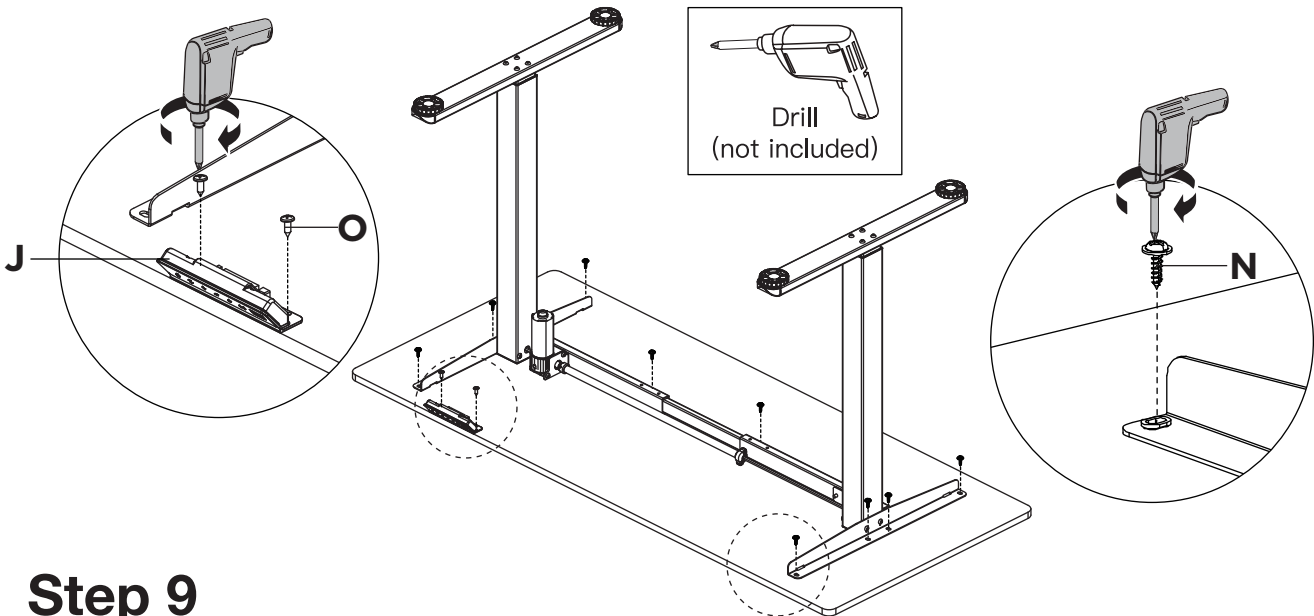

Step 9

Connect the Power Lines and Attach the Cable Clips

Connect the Power Lines

Connect the Power Lines as shown in the image.

Attach the Cable Clips

Attach the Cable Clips (#R) to the underside of the desktop as needed. It is recommended that they be placed approximately in the middle of each length of wire to prevent the cords from hanging too low.

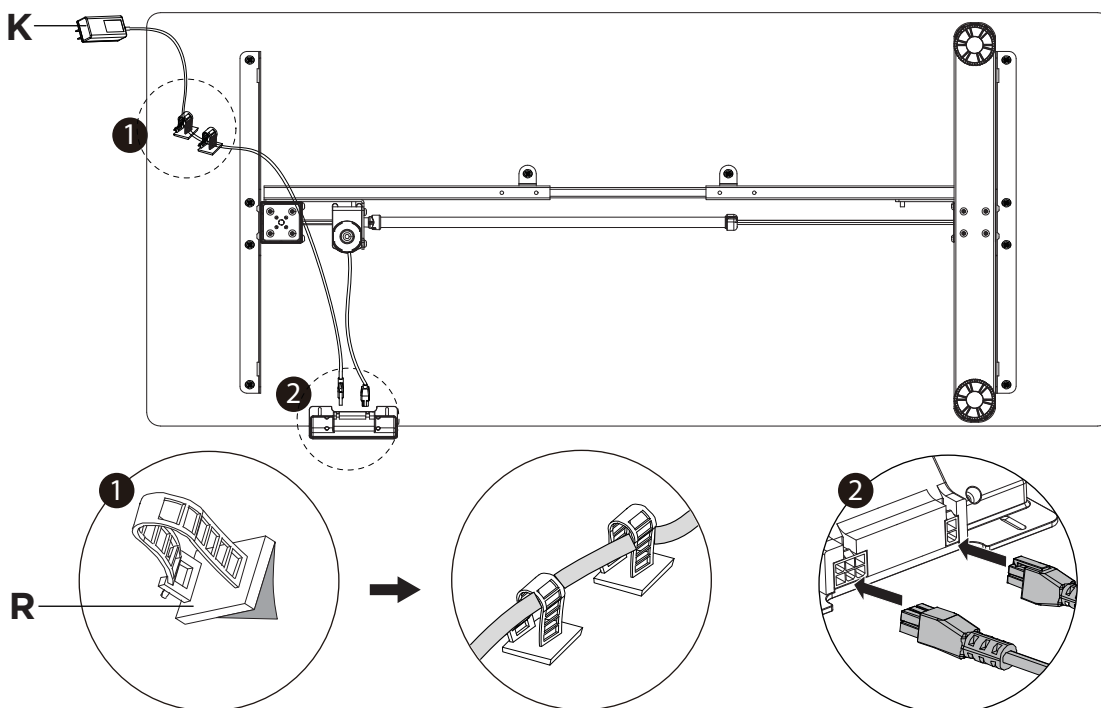

Step 10

Connect the Power

Flip the desk assembly over and connect the Power Adapter (#K) to a wall outlet.

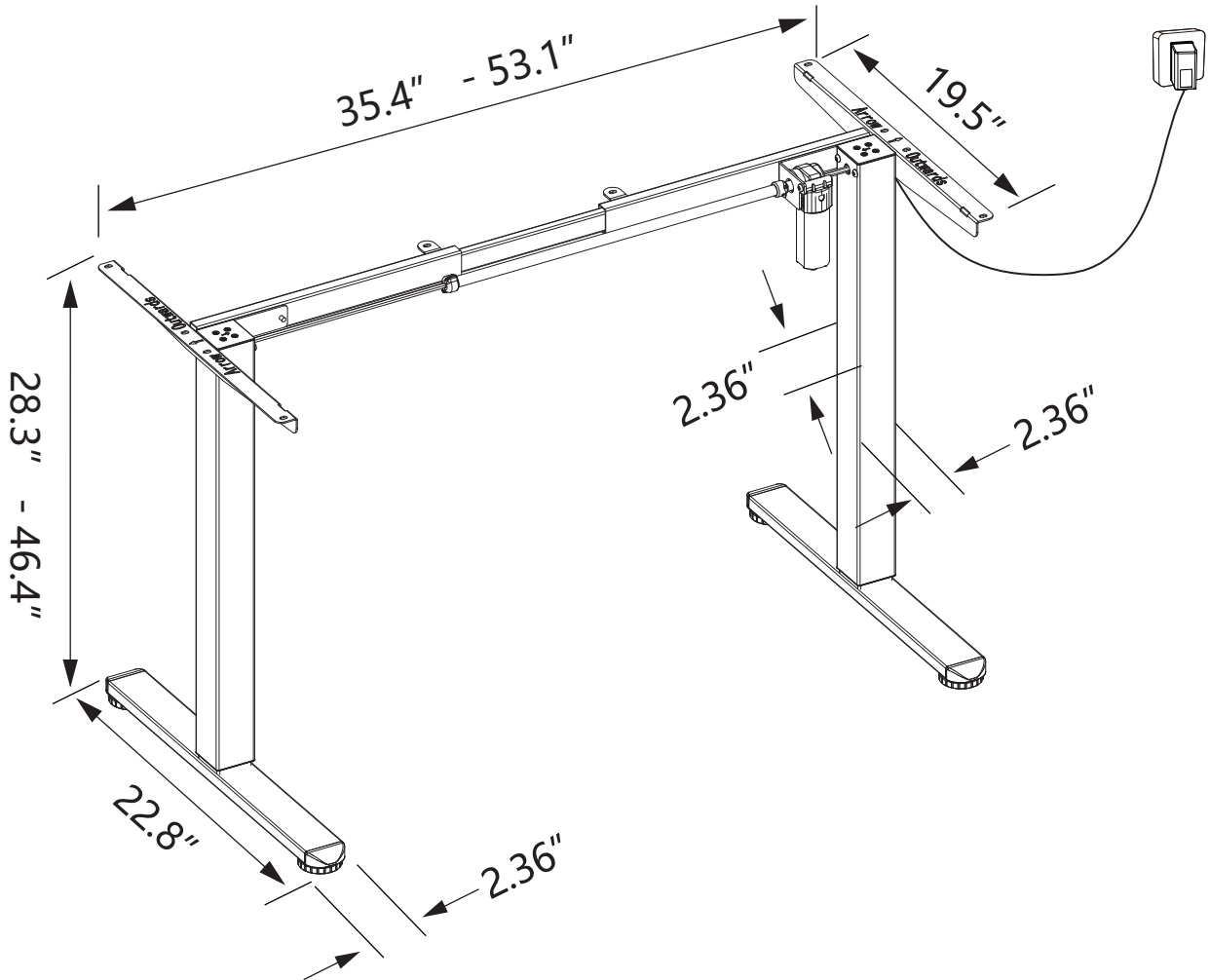

Power Input
100V-240V



Speed
20 mm/s



Motion Noise
<55dB



Load Capability
154 lbs / 70 kg

Warnings



Do not exceed desk weight limit.



Keep area of vertical motion free of obstacles.



Keep weight on desk balanced for correct operation and longer life of components.

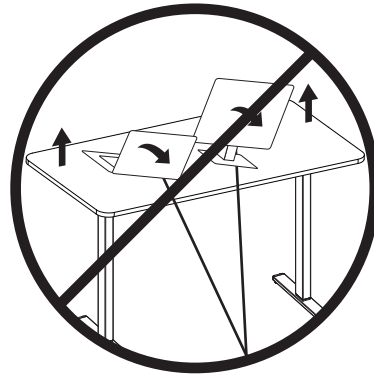

Leave enough slack in cables to allow for full range of vertical motion.

Visit us at www.mount-it.com for product registration and warranty information.

Our US based customer service team is standing by to answer any questions you have about your Mount-It! product.

Available by phone **Monday - Friday from 8:00am to 4:00pm PST.**

Chat live with an agent on our website!



support@mount-it.com



(855) 925-5668



www.mount-it.com