

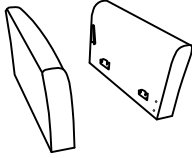

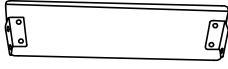
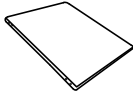
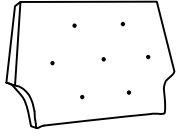
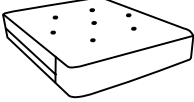

Assembly Instructions

<p>Ax1</p> 	<p>Bx2</p> 	<p>Cx1</p> 	<p>Dx1</p> 	<p>Ex1</p> 
<p>Fx1</p> 	<p>Gx4</p> 	<p>Hx4</p> 	<p>Ix16</p>  <p>M6*16mm</p>	<p>Jx1</p> 

1 First, use the accessory "J" to unscrew the screws on "B". Then, align the holes on the iron piece of "C" with the screw holes on the handrail, and fix it with screws.

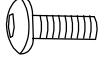

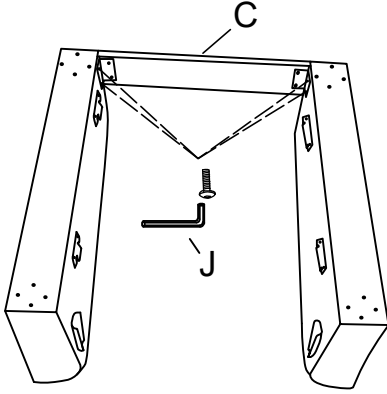
2

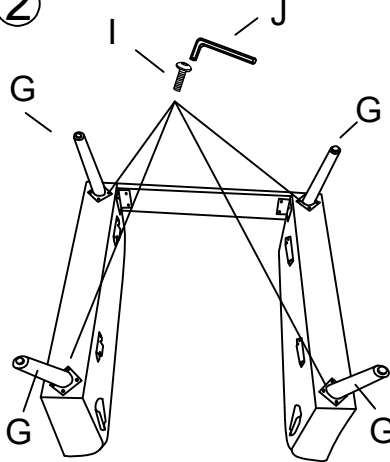

3 First, use the "J" attachment to unscrew the screws on "D". Then, align the holes on "H" with the screw holes on "D", and fix it with screws.

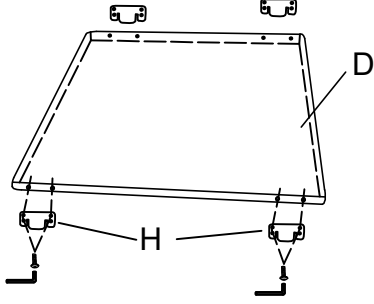

4

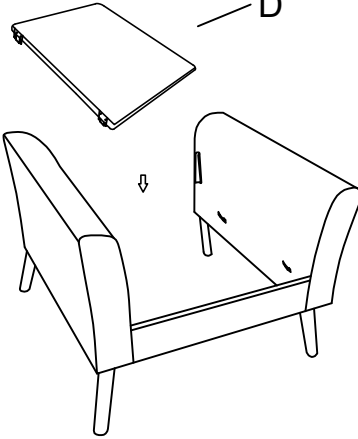

5

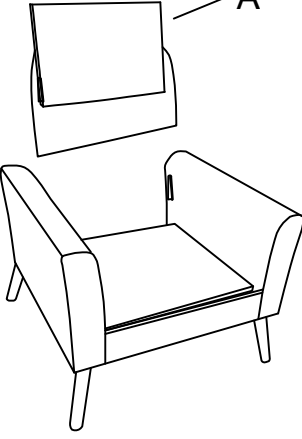

6

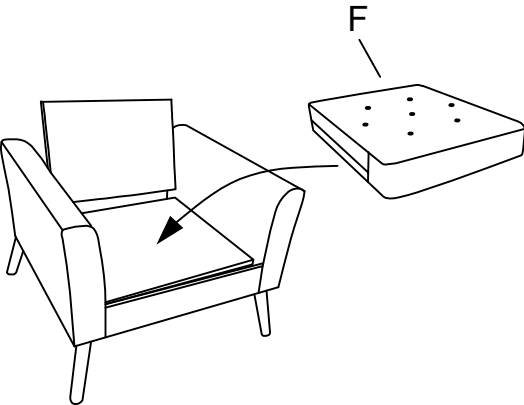

6

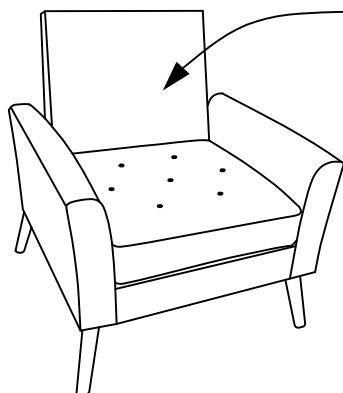

7

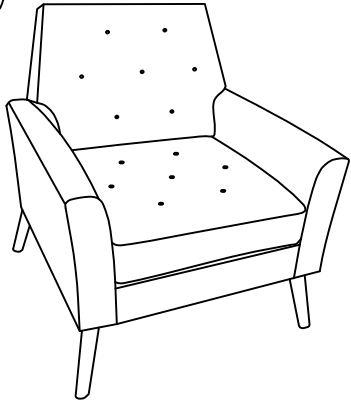

Please note: We provide fast after-sales service, don't worry if there is something wrong with the package you received. Please contact us first, we will reply you in time!