

Installation Instruction

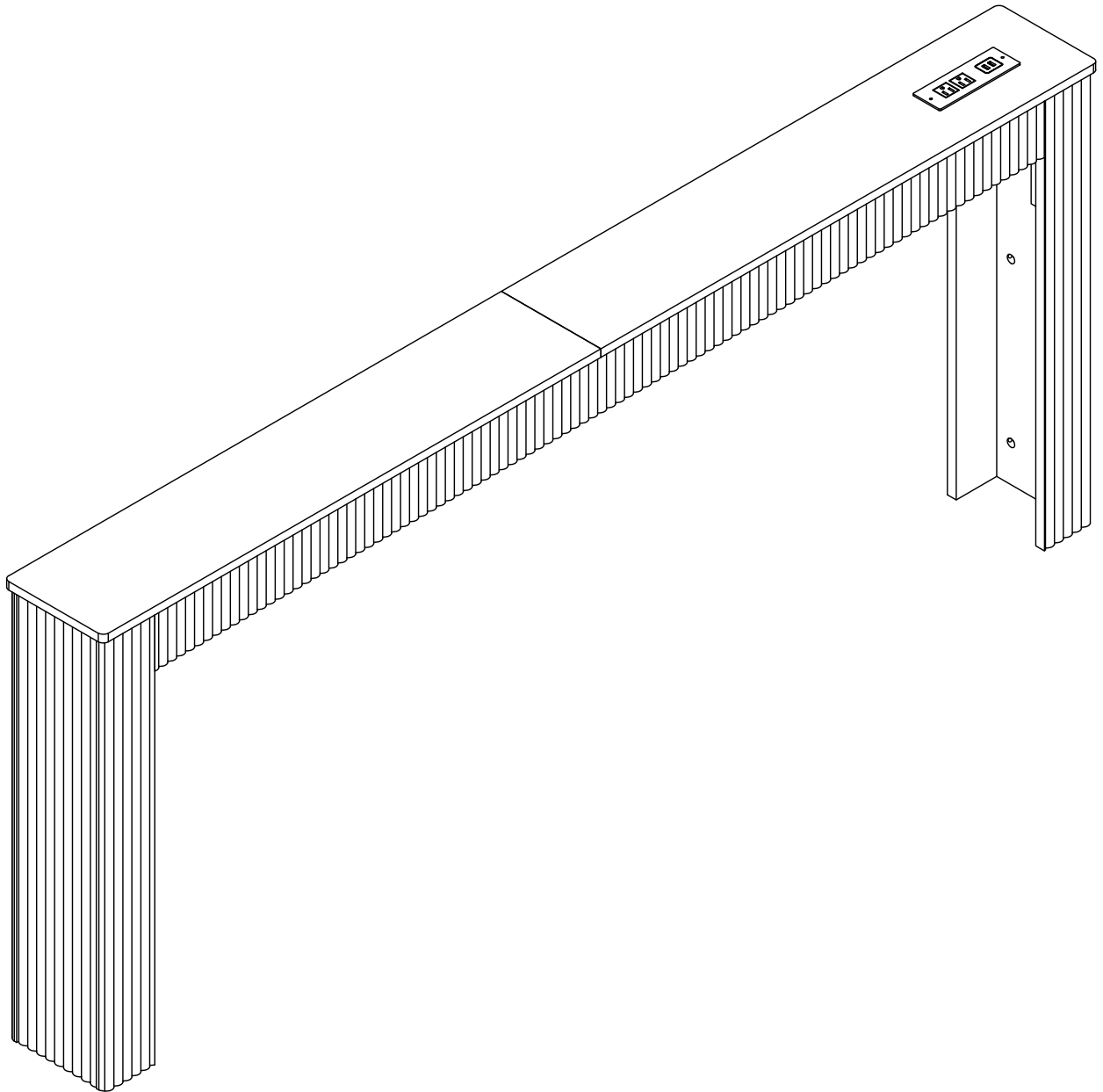

Assembling

What you need

- Use the packaging carton as a working surface to prevent product damage during assembly
- Phillips head screwdriver

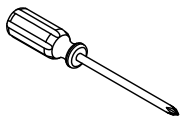

Weight Limitation

100 | **35**
 lbs table top lbs per

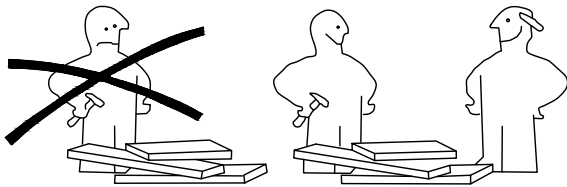

What' included

Code	Description	Qty
A	Cam Bolt M6X35MM	33
B	Cam Lock 15X10MM	33
C	Wooden Dowel M8X30MM	36
D	Screw M4X40MM	2
E	The screw M3.5X14MM	2
F	Circular hole Decals	33
G	Screw M3.5X12MM	2
H	Screw M6X25MM	16
I	Screw M6X50MM	12
J	Screw M6X30MM	8
K	Screw M6X15MM	4
L	Wrench M4X55MM	1
M	EVA Foot mat	6
N	Nylon Strap	2
O	Anchor	2
P	Sheet iron	2
Q	Extension cord	1

The Hardwares

A

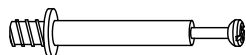

B

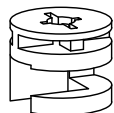

C



D

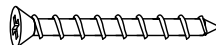

E



F



G

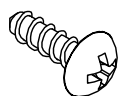

H



I



J



K



L



M

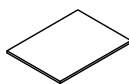

N

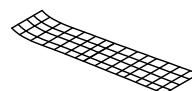

O



P



Q

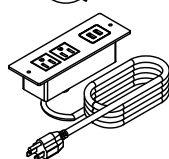

IMPORTANT:

1. Do not tighten bolts / screws completely until all bolts / screws are lined up and inserted into holes.
2. Do not over tighten screws and bolts to avoid stripping
3. Please use hand tools to assemble this product, you can also use power tools (please use power tools carefully)

Included Accessories

Code	Description	Qty
1	Left Side Panel	1
2	Right Side Panel	1
3	Side Panel	2
4	Pre-Support Plate	2
5	Rear-Support Plate	2
6	Left connecting plate	2
7	Right connecting plate	2
8	Reinforcing Rib	4
9	Metal Frame	1

The Accessoriess

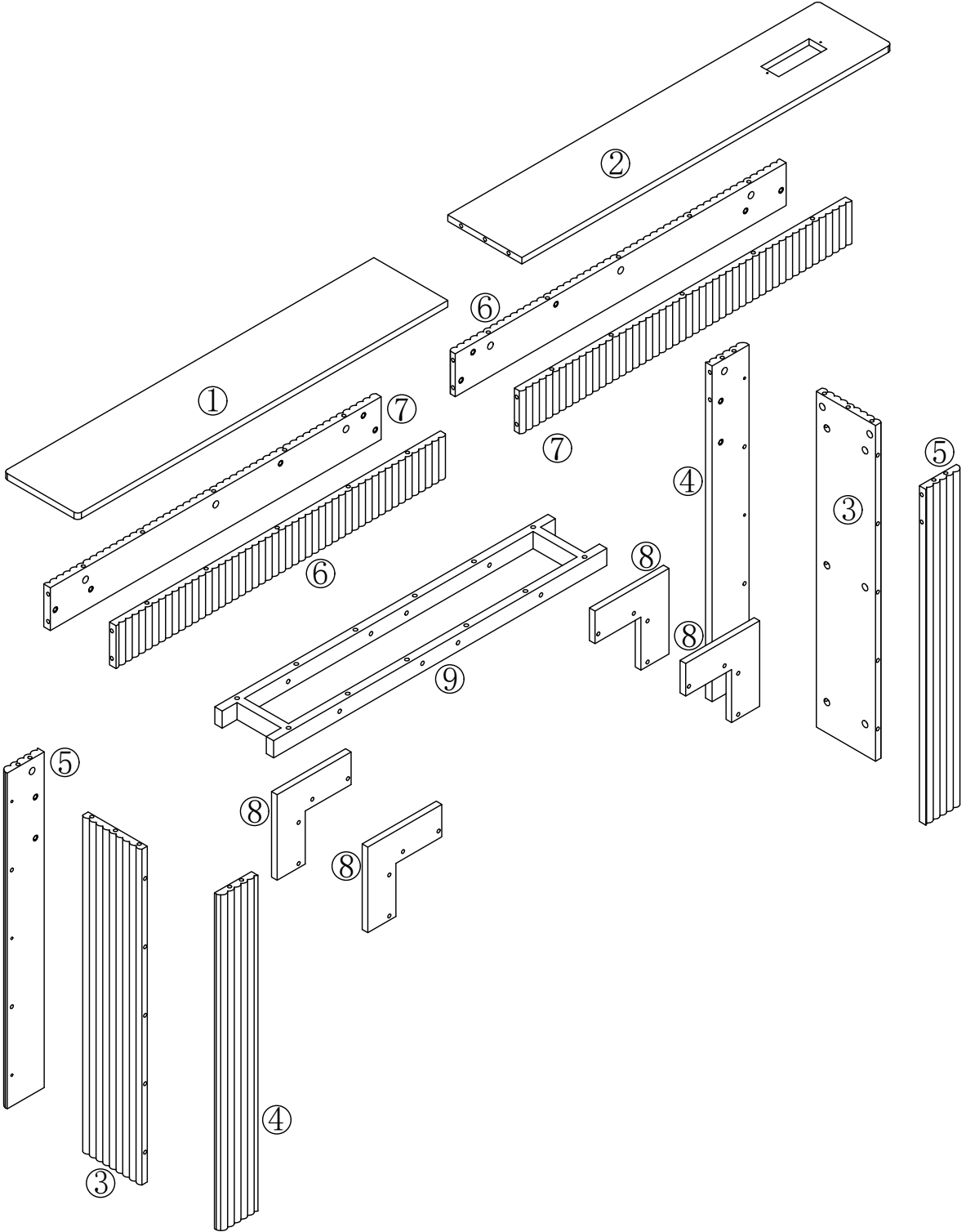

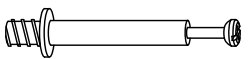

Step 1

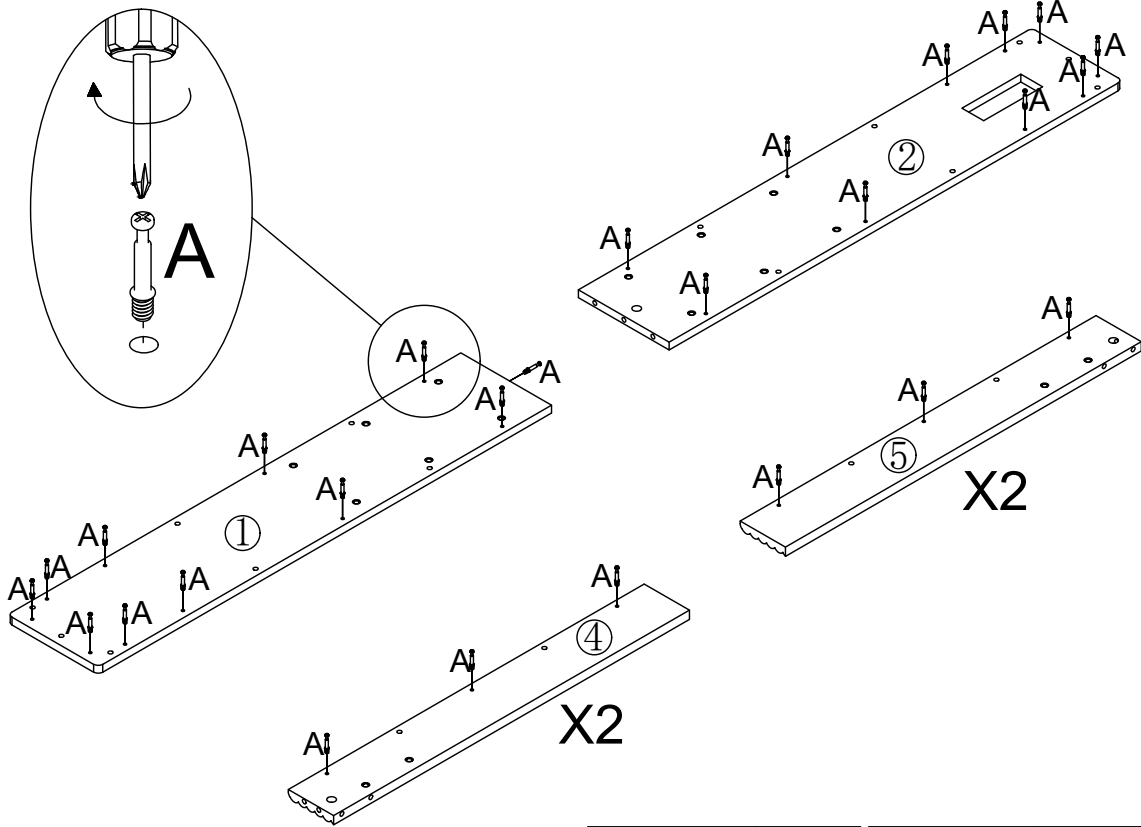
A	×33
	

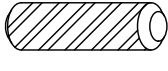

Step 2

B	×12	C	×8	F	×12
					

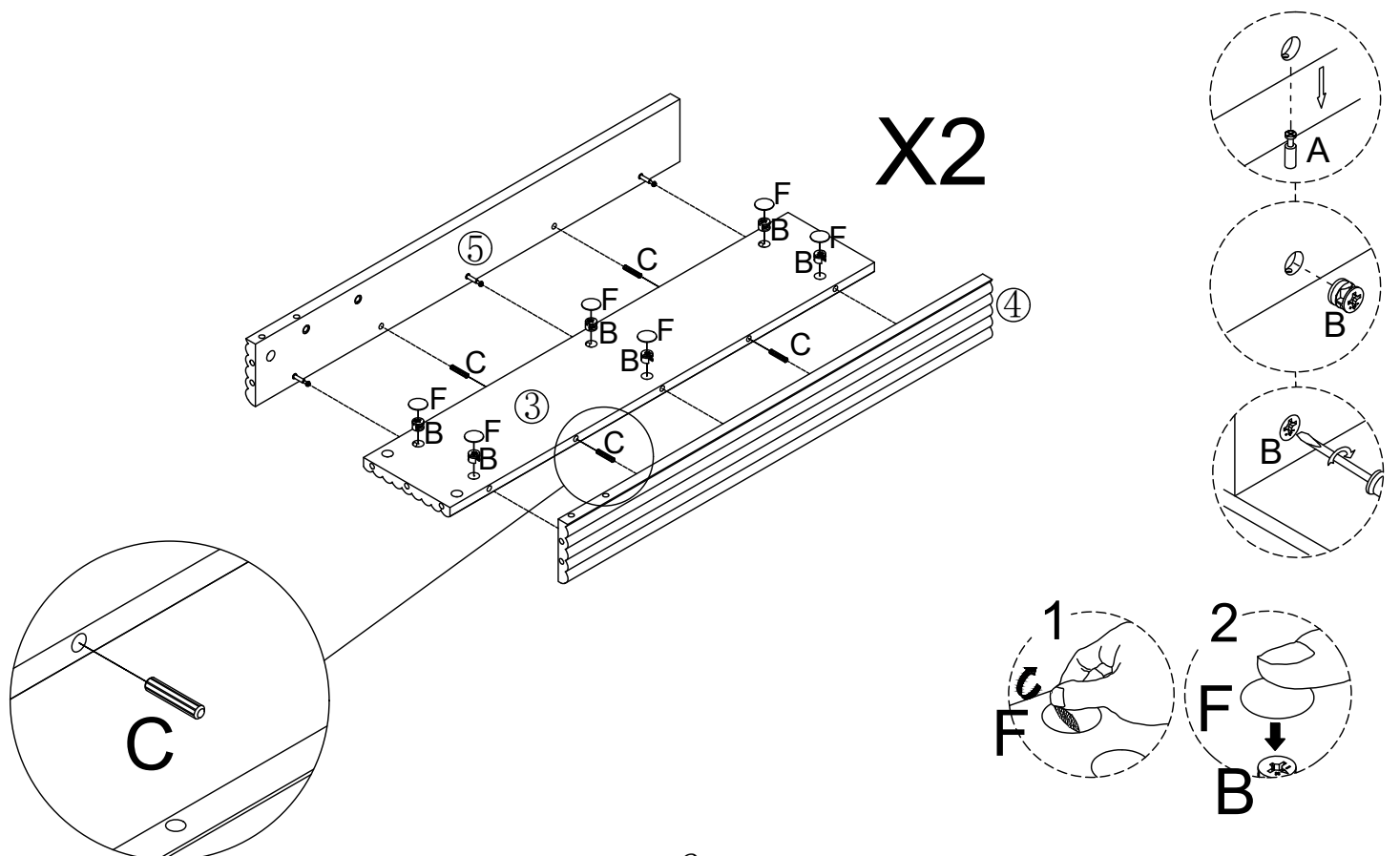

Step 3

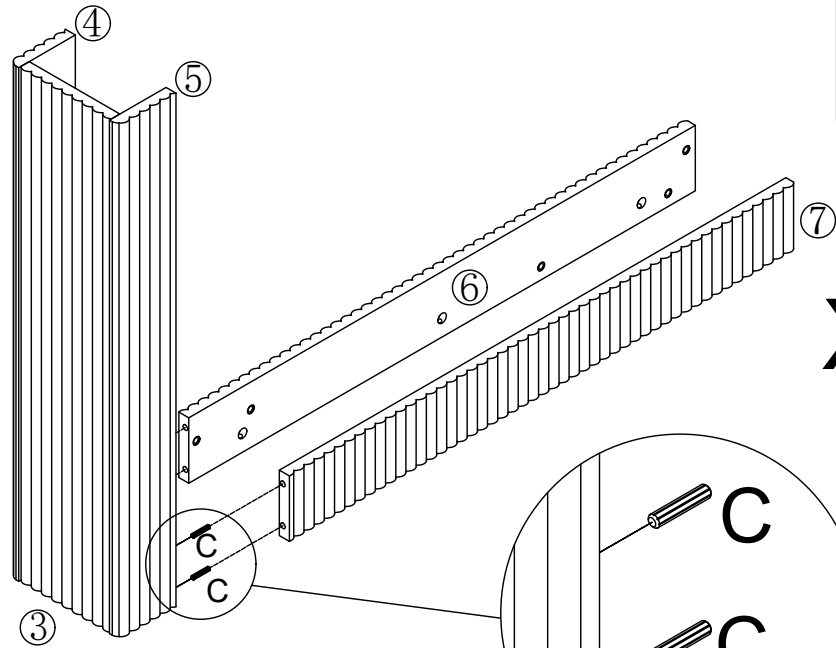

C	×8

X2

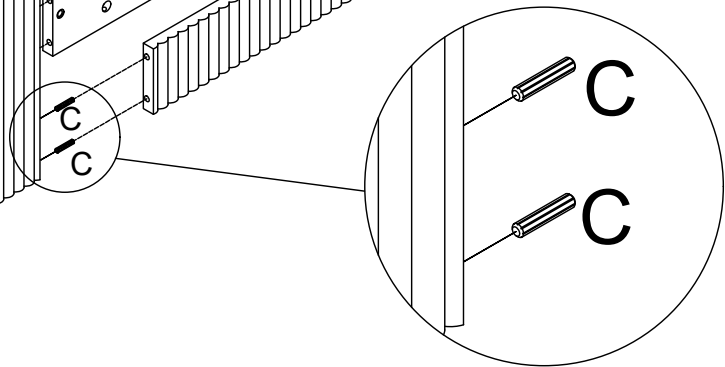

Step 4

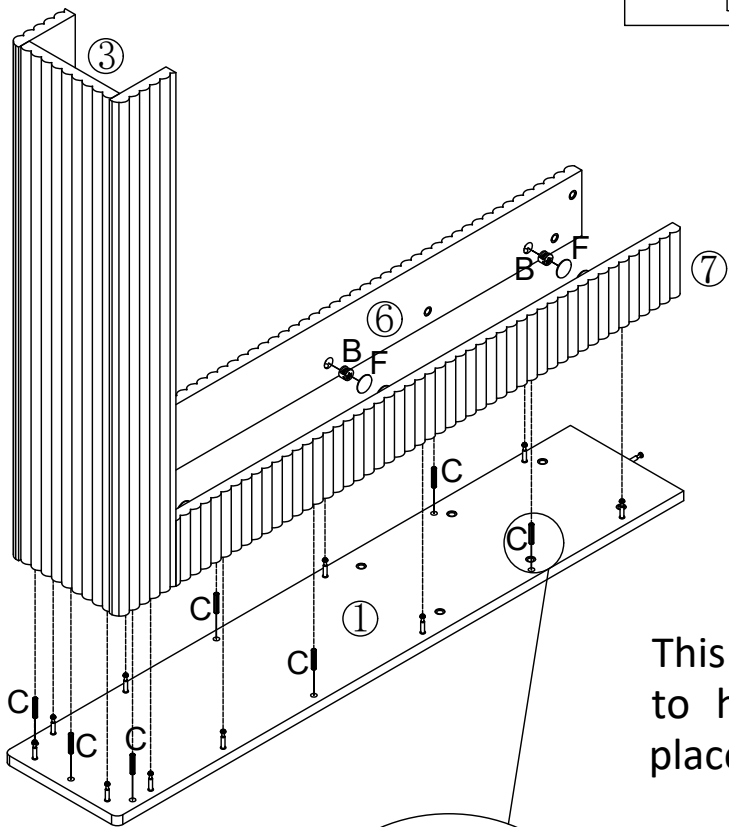

B	×10	C	×7	F	×10

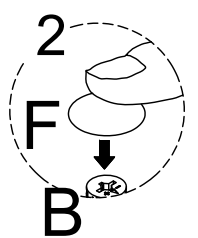
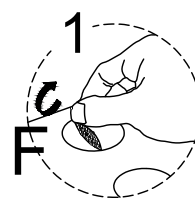
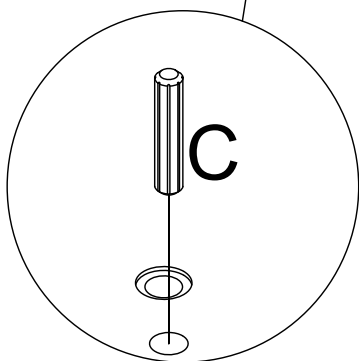
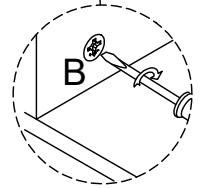
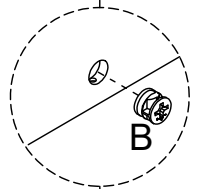
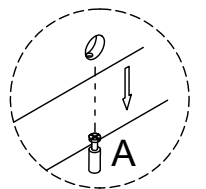

This step requires two people to help align the holes and place them down.

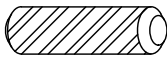

Step 5



B	×10	C	×7	F	×10
					

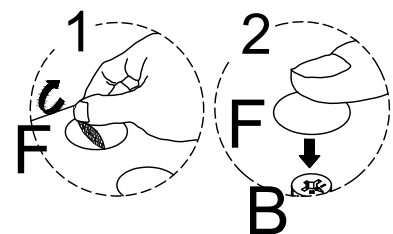
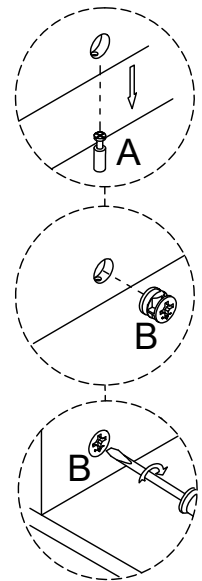
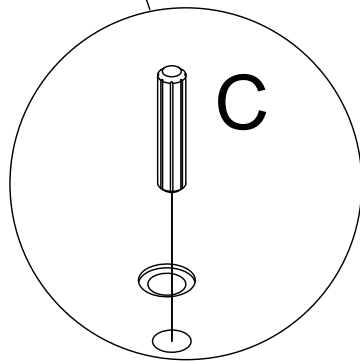
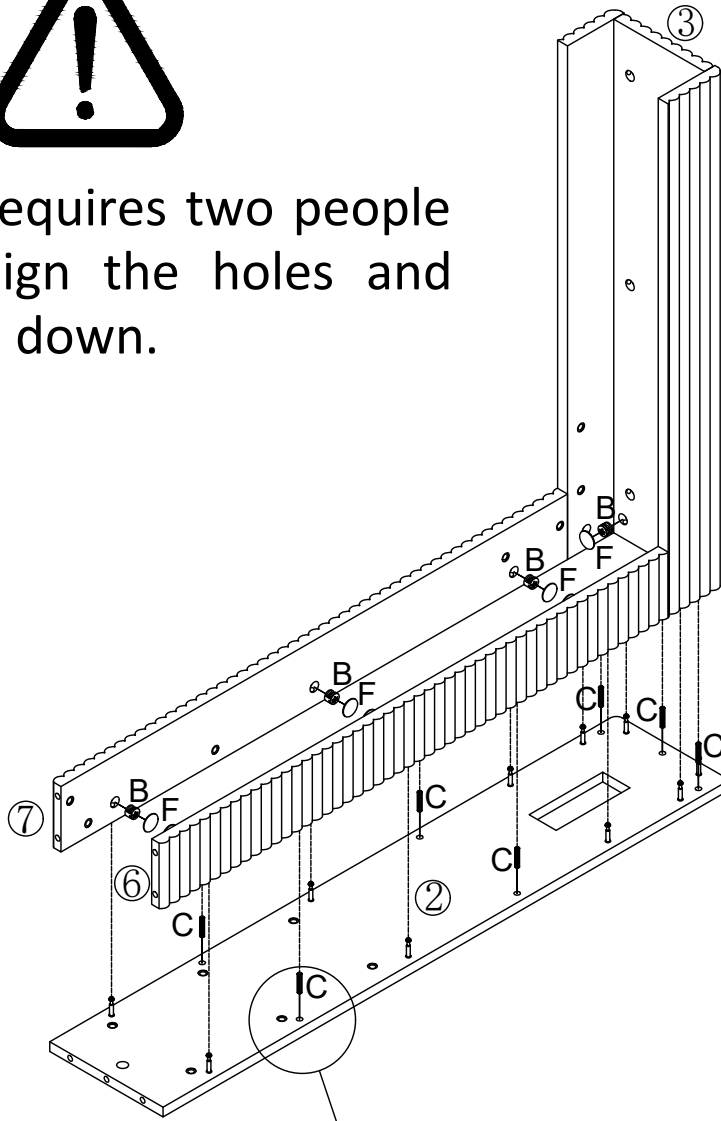

This step requires two people to help align the holes and place them down.

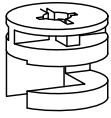
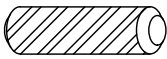

Step 6



B	×1	C	×6	F	×1
					

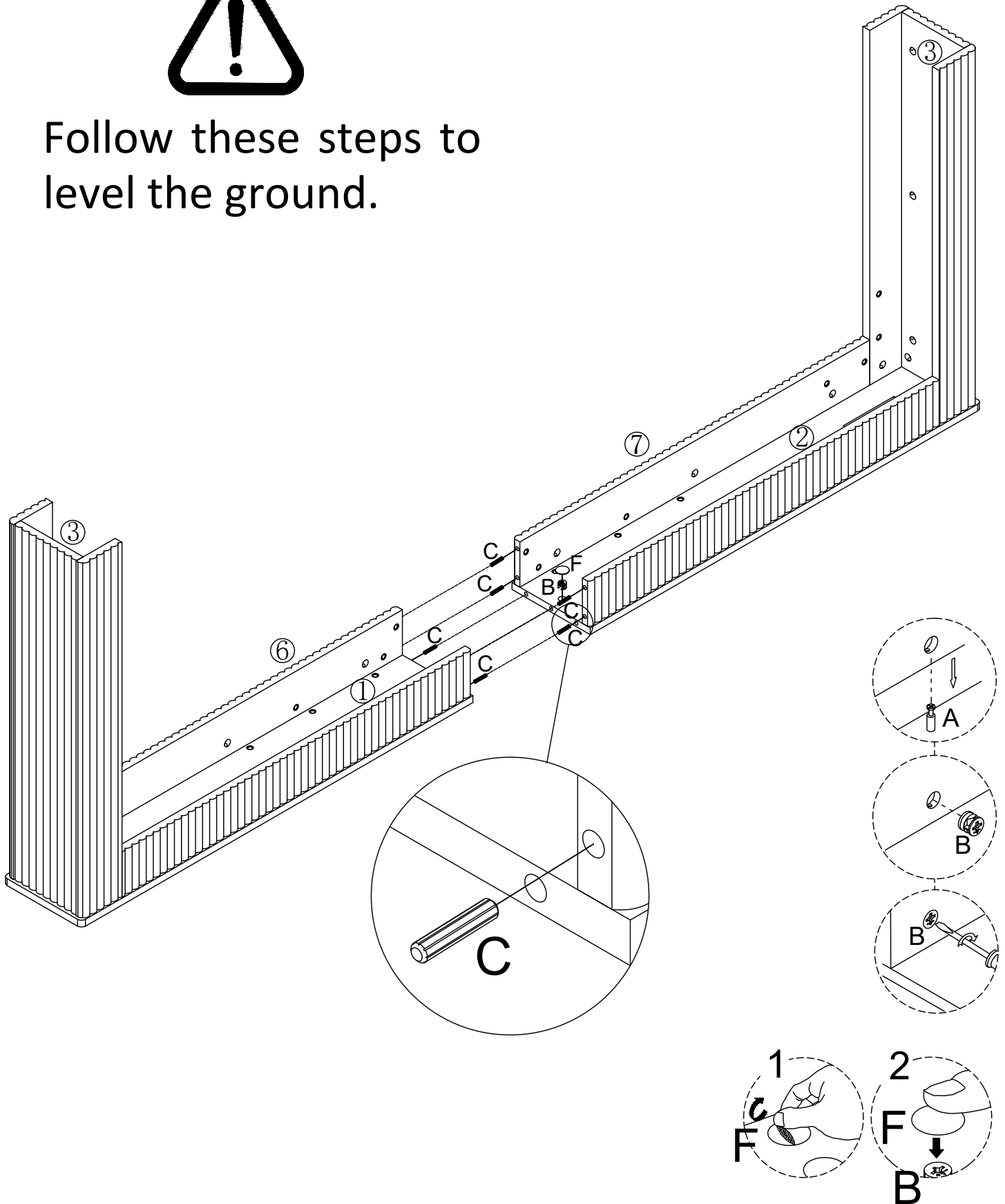

Follow these steps to level the ground.

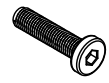

Step 7

H	×16	L	×1
 M6X25MM			



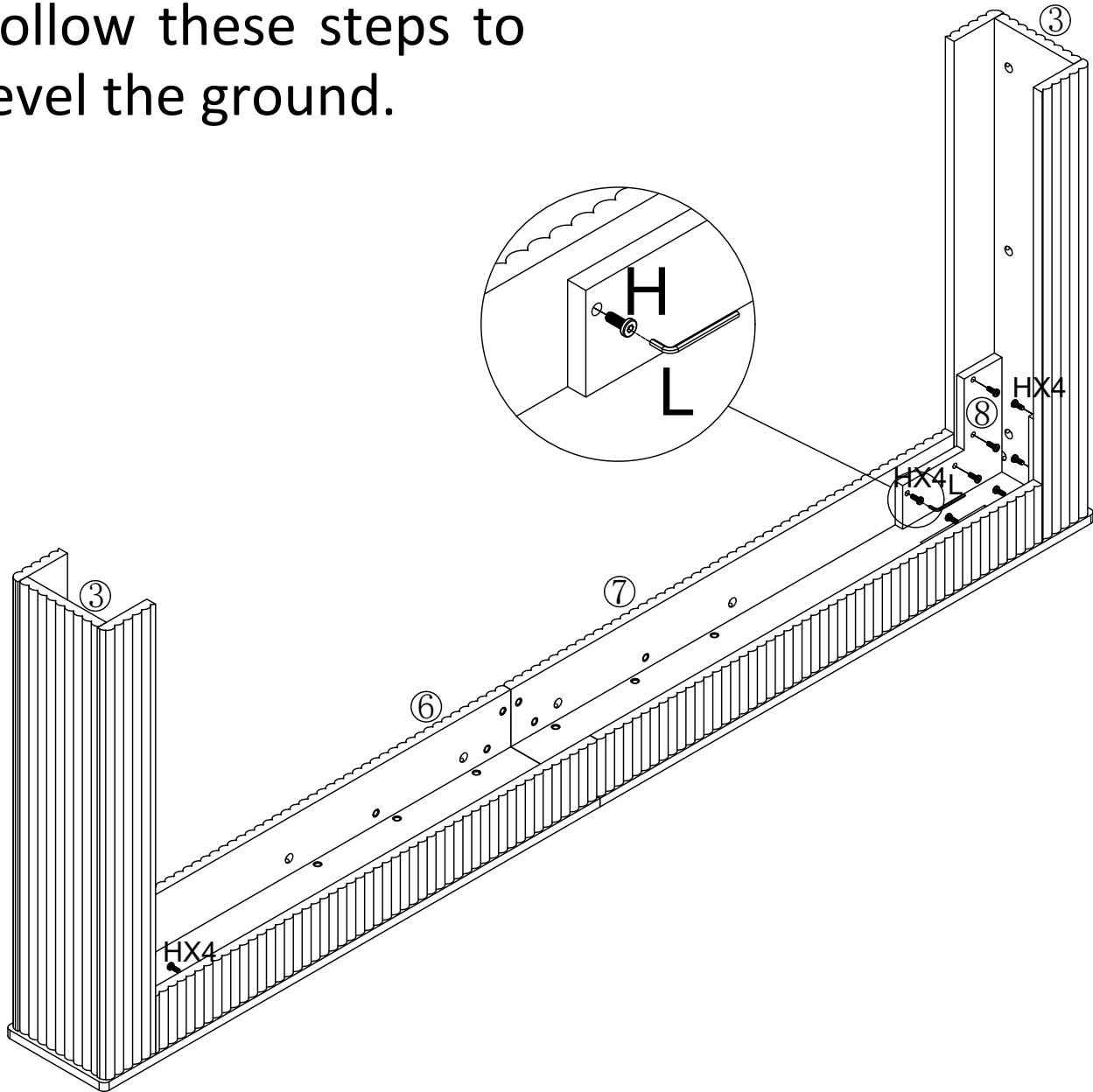

Follow these steps to level the ground.



Step 8

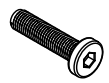

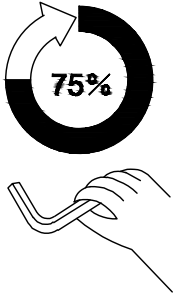

I	×12	L	×1
 M6X50MM			

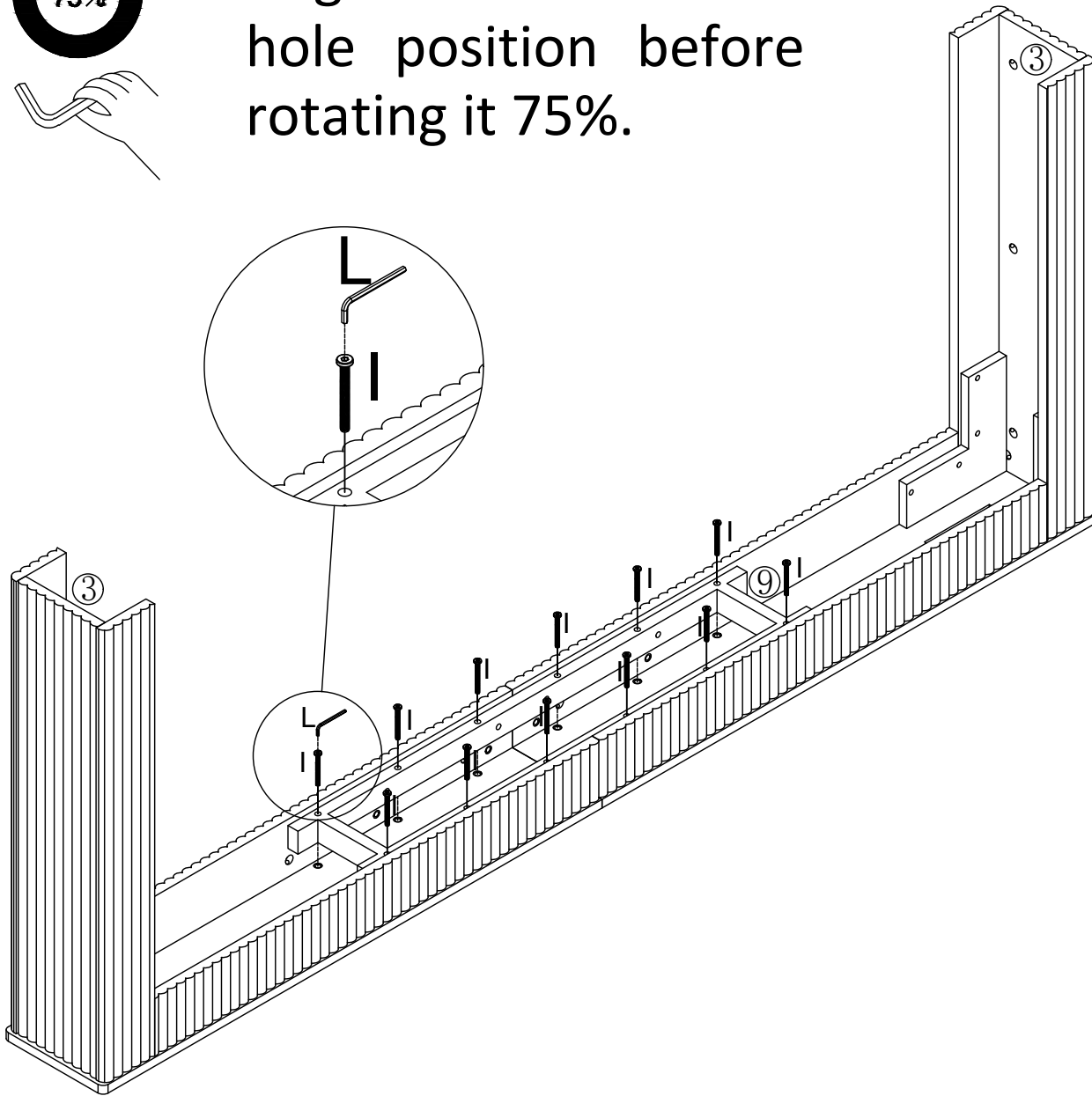

Align screw I with the hole position before rotating it 75%.

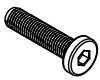

Step 9

J	×8	L	×1
 M6X30MM			

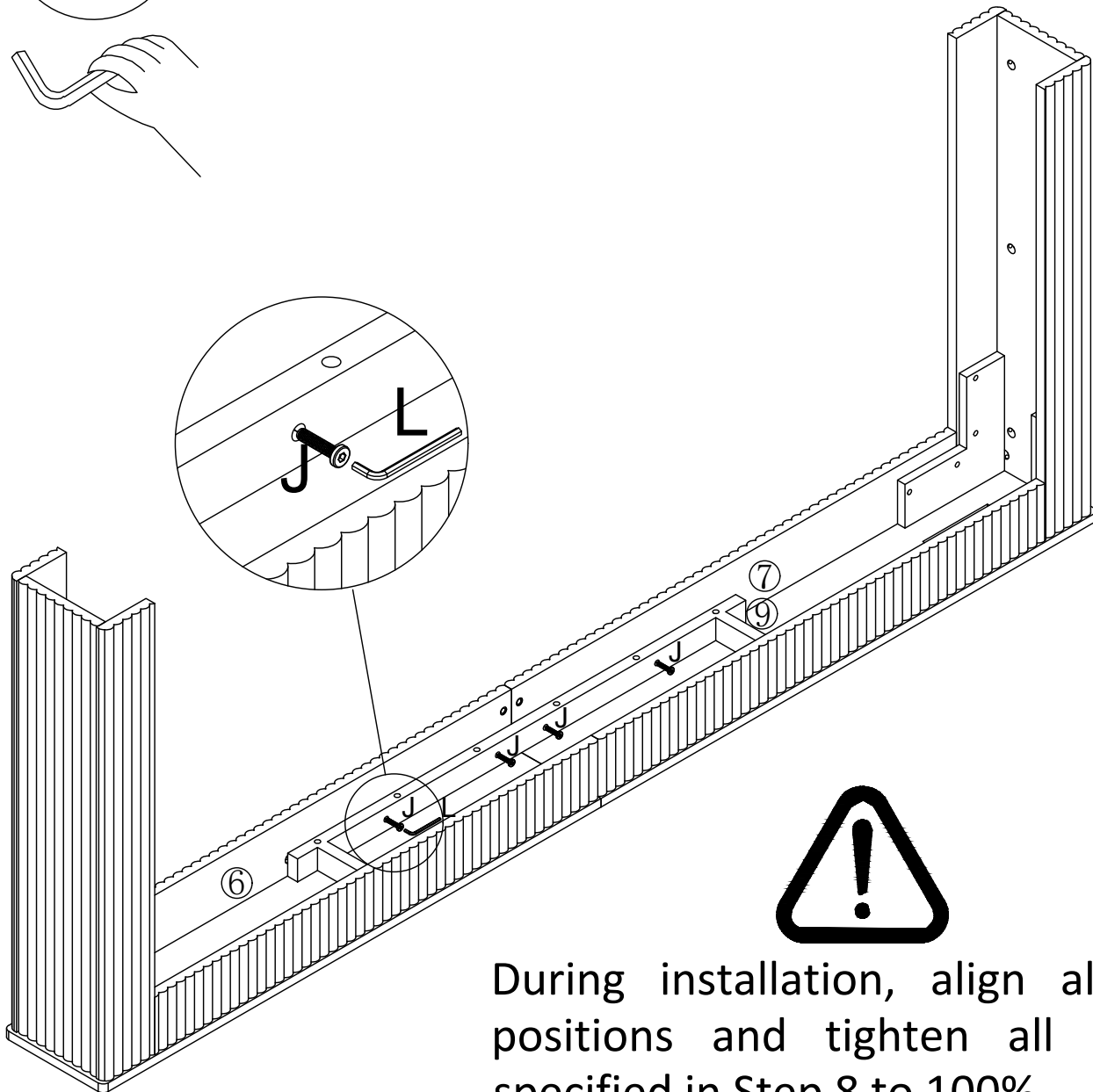
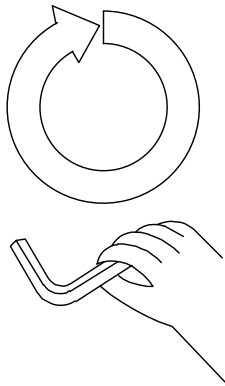

During installation, align all hole positions and tighten all screws specified in Step 8 to 100%.

Step 10

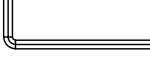
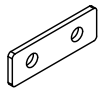
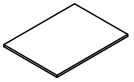
K	×4	L	×1	P	×2
 M6X15MM					
M			×6		

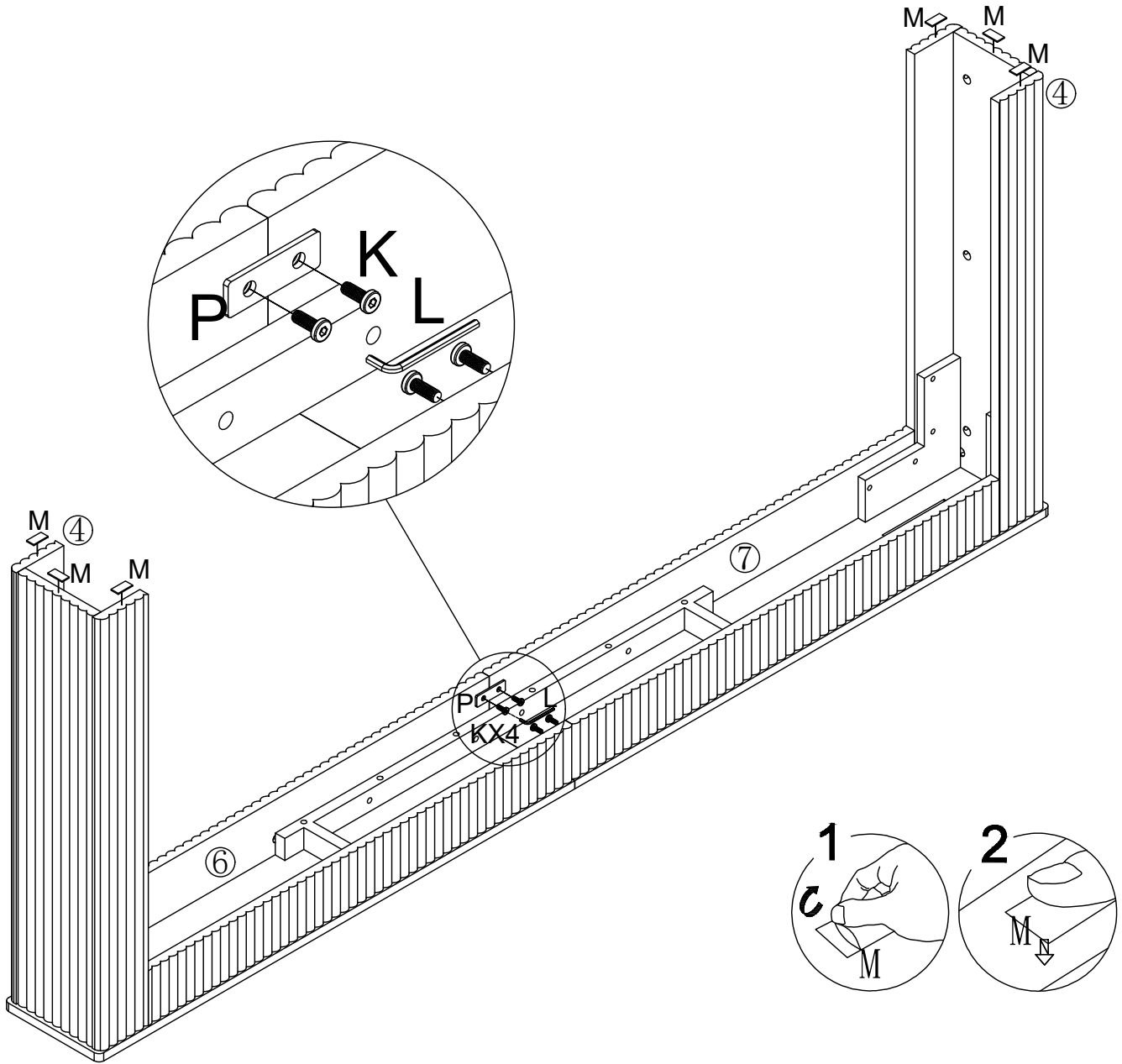

Step 11

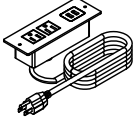
E	×2	Q	×1
			

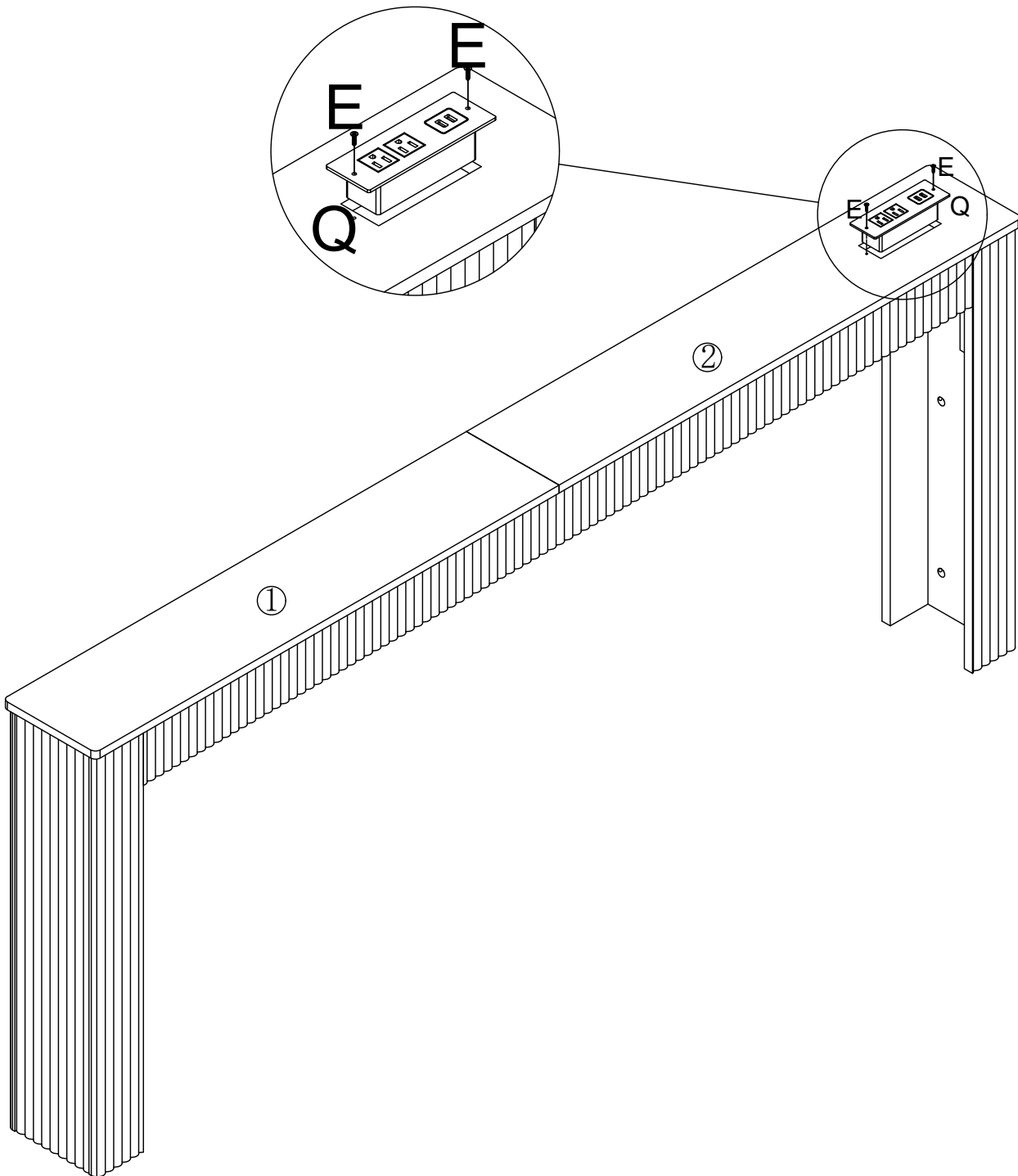

Step 12

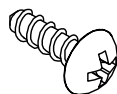
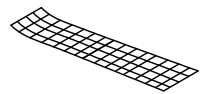
G	×2	N	×2
			

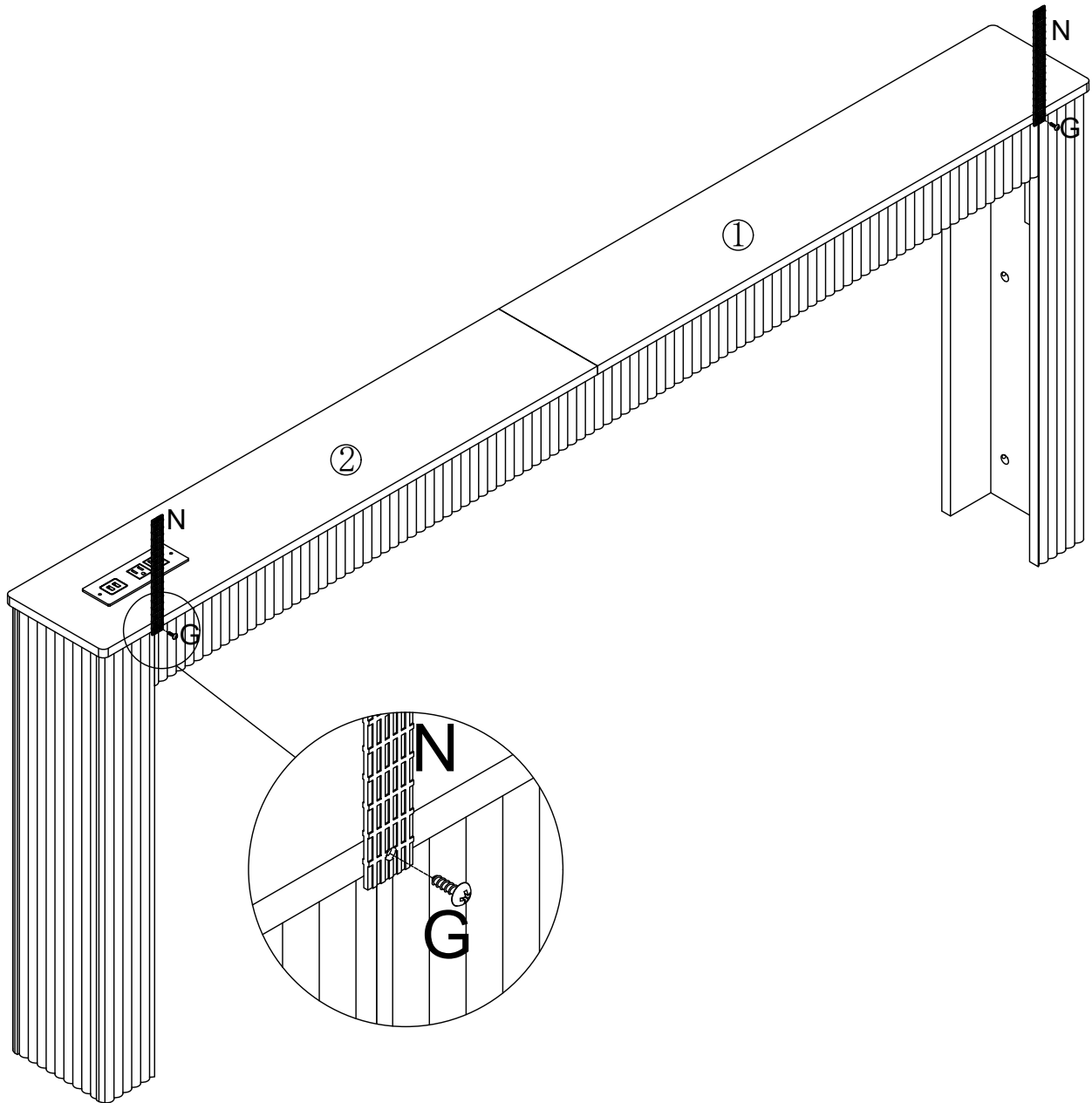

Step 13

D	×2	O	×2
