

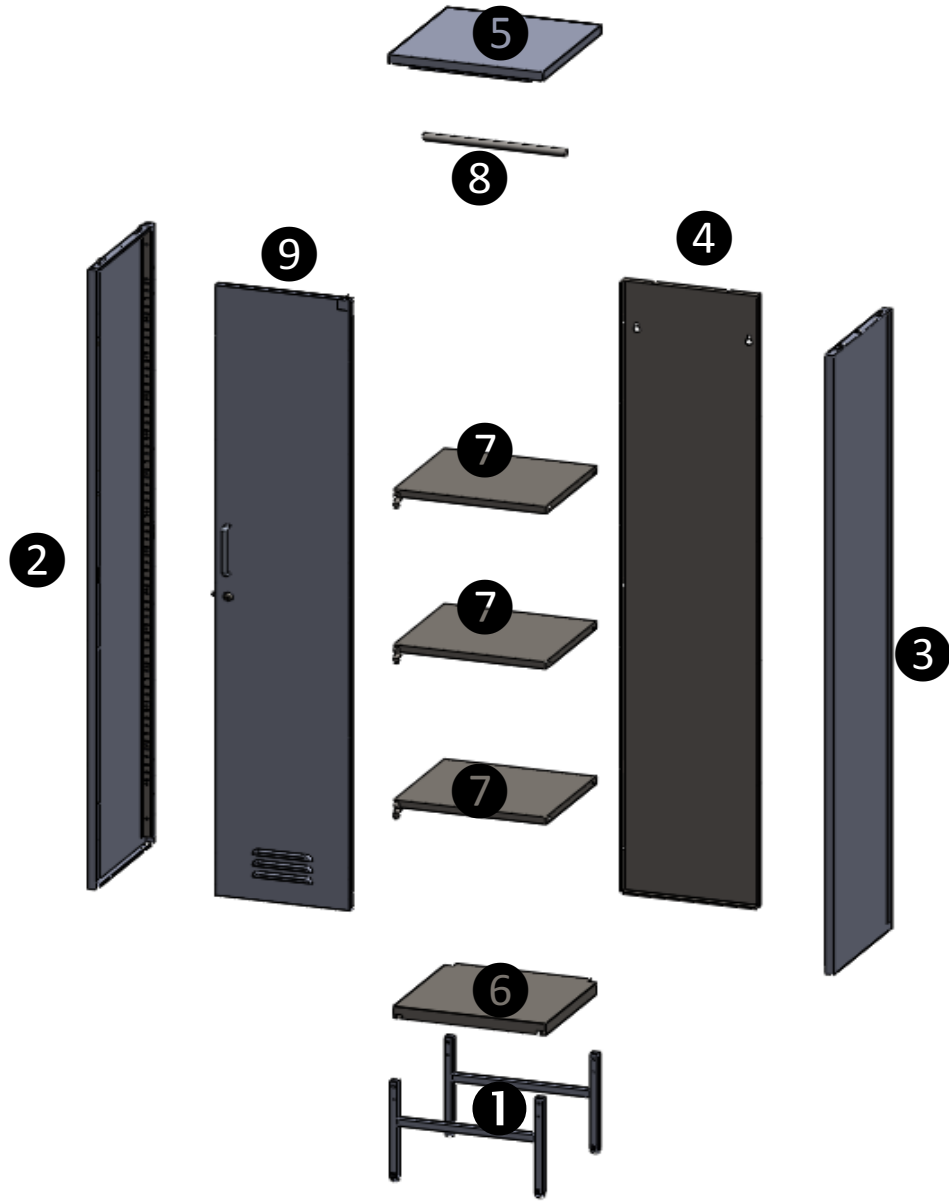

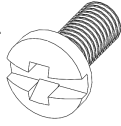

assembly guide

parts breakdown

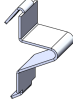
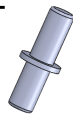

A  M4*5 X2	B  X12	C  X1	D  X12	E  X1
---	---	--	---	--

step 1

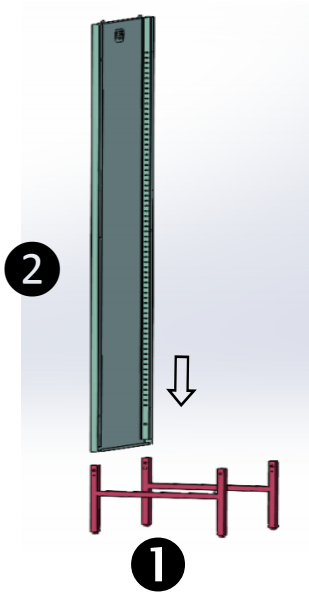

Assemble the left side panel and the legs with two screws on the bottom.

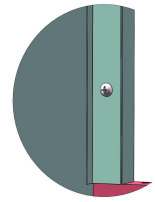
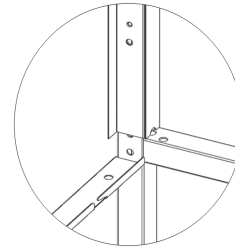
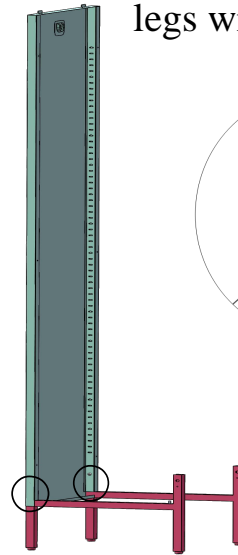

X2

step 2

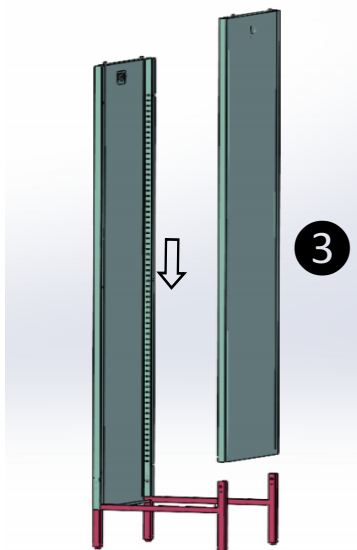

Assemble the right side panel and the legs with two screws on the bottom.

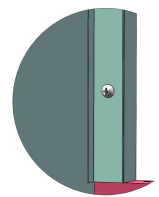
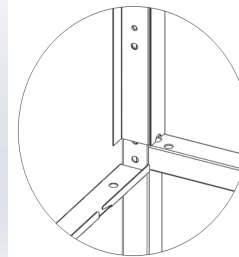
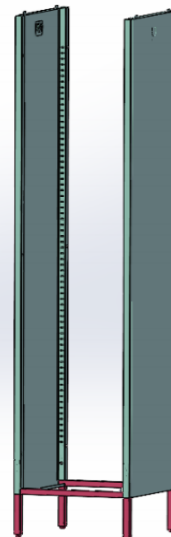

X2

step 3

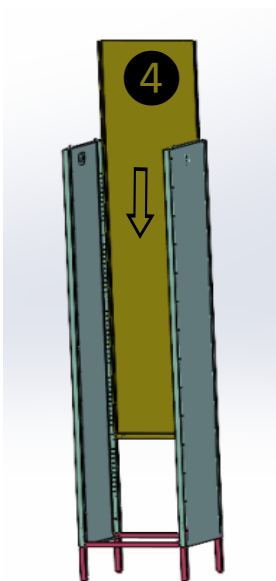

Assemble the back panel and two side panels with 3 screws on each side.

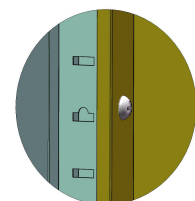
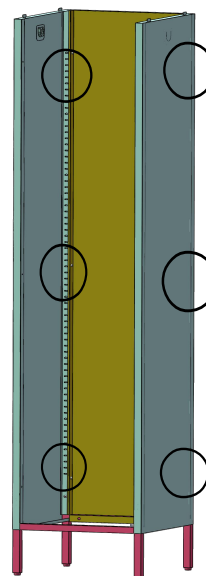
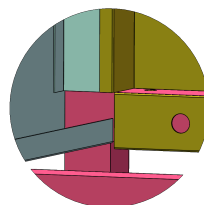

X6

step 4

Cover the top on the side panel and back panel, pls make sure the chip on the side panels plug into the holes of the top panel "5".

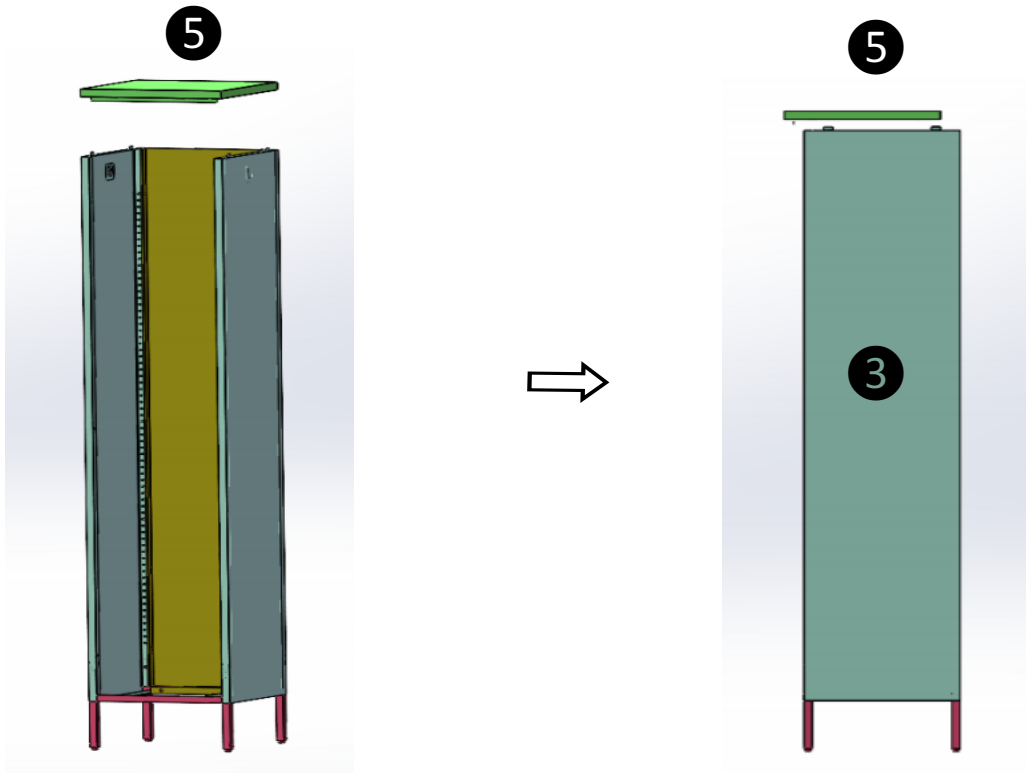

Fix the top panel and back panel with 2 screws on the back.

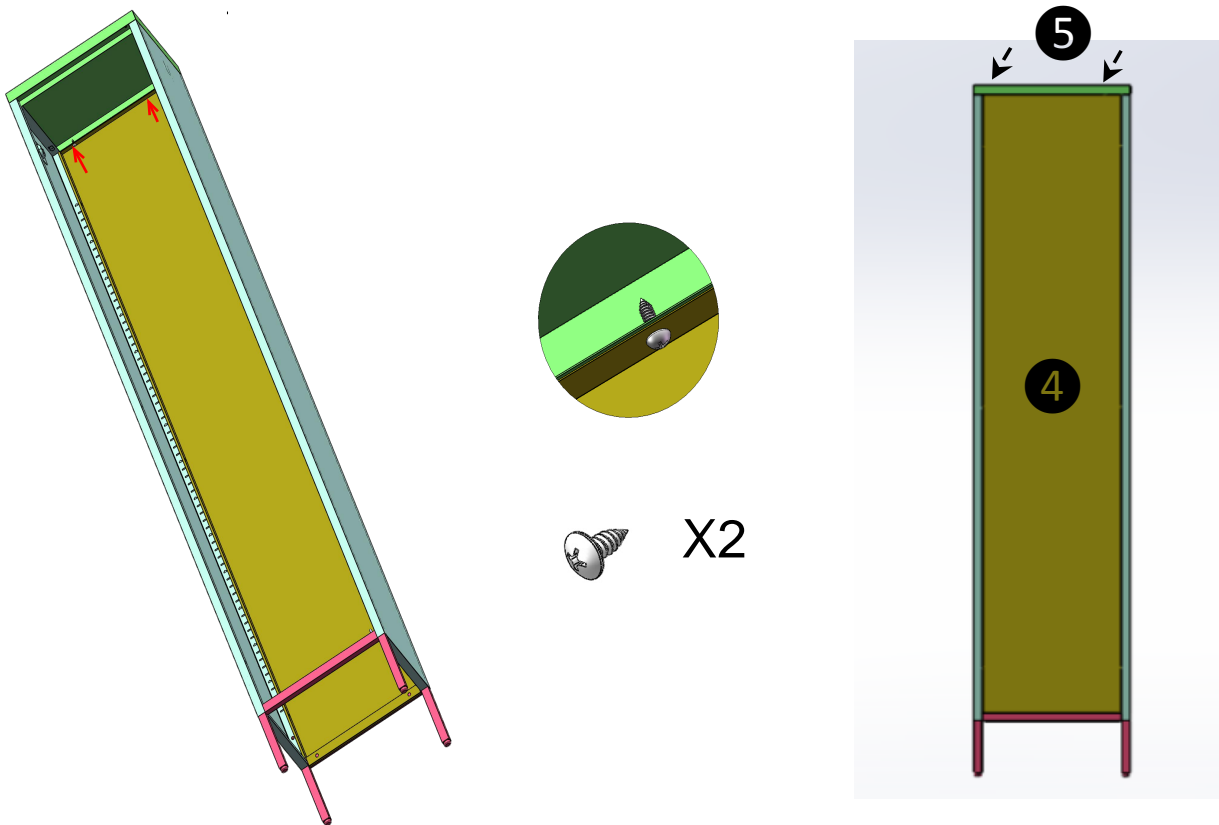

step 5

Assemble the bottom panel "6" to make it cover on the leg.

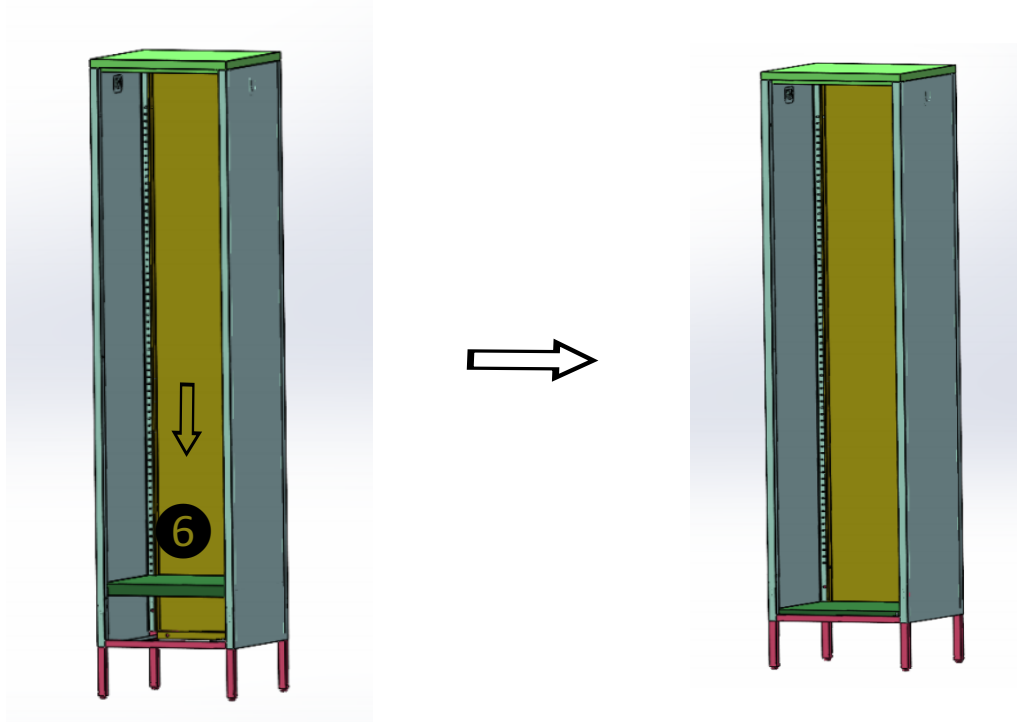

Plug the below clips into the holes on the side panel to support the shelf, 4 clips for one shelf, pls make sure the 4 clips are in the same level.
You can change the height of the shelf as you need.

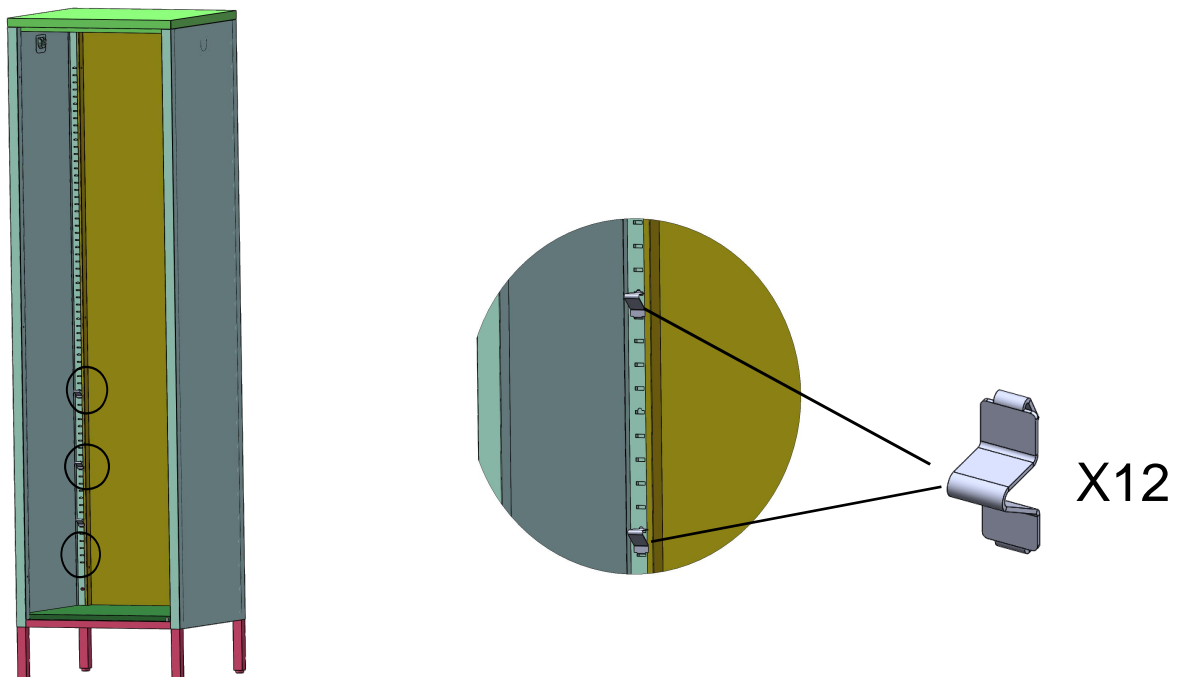

step 6

Assemble the other shelves as the picture below.

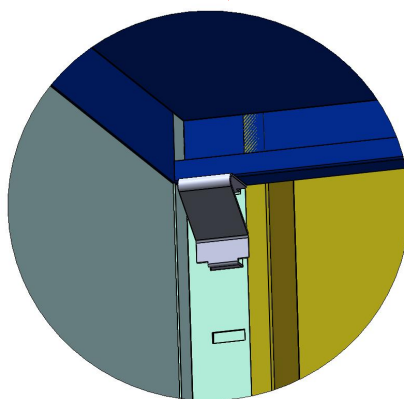
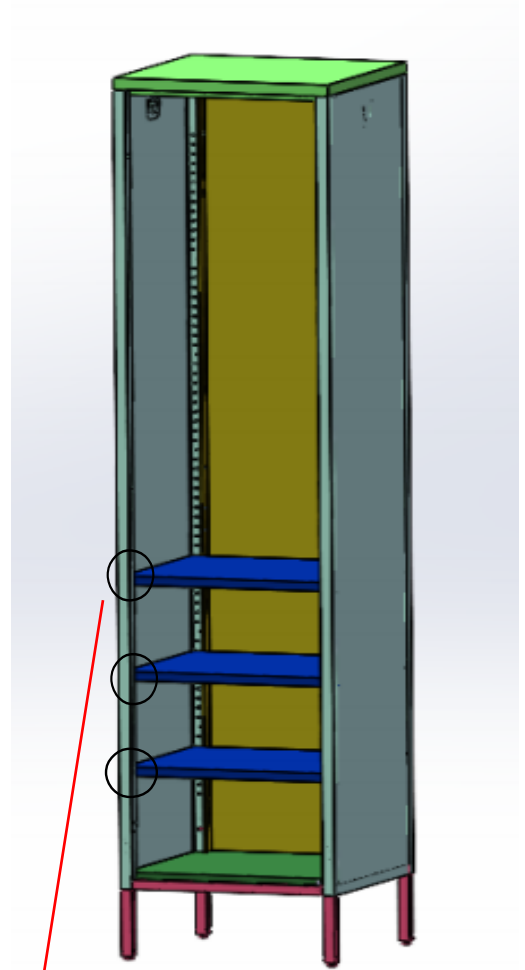
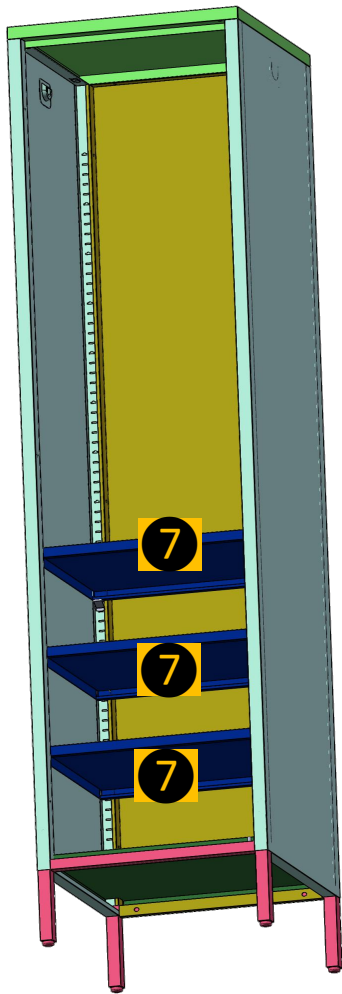

step 7

Assemble the hanger into the holders on the side panel.

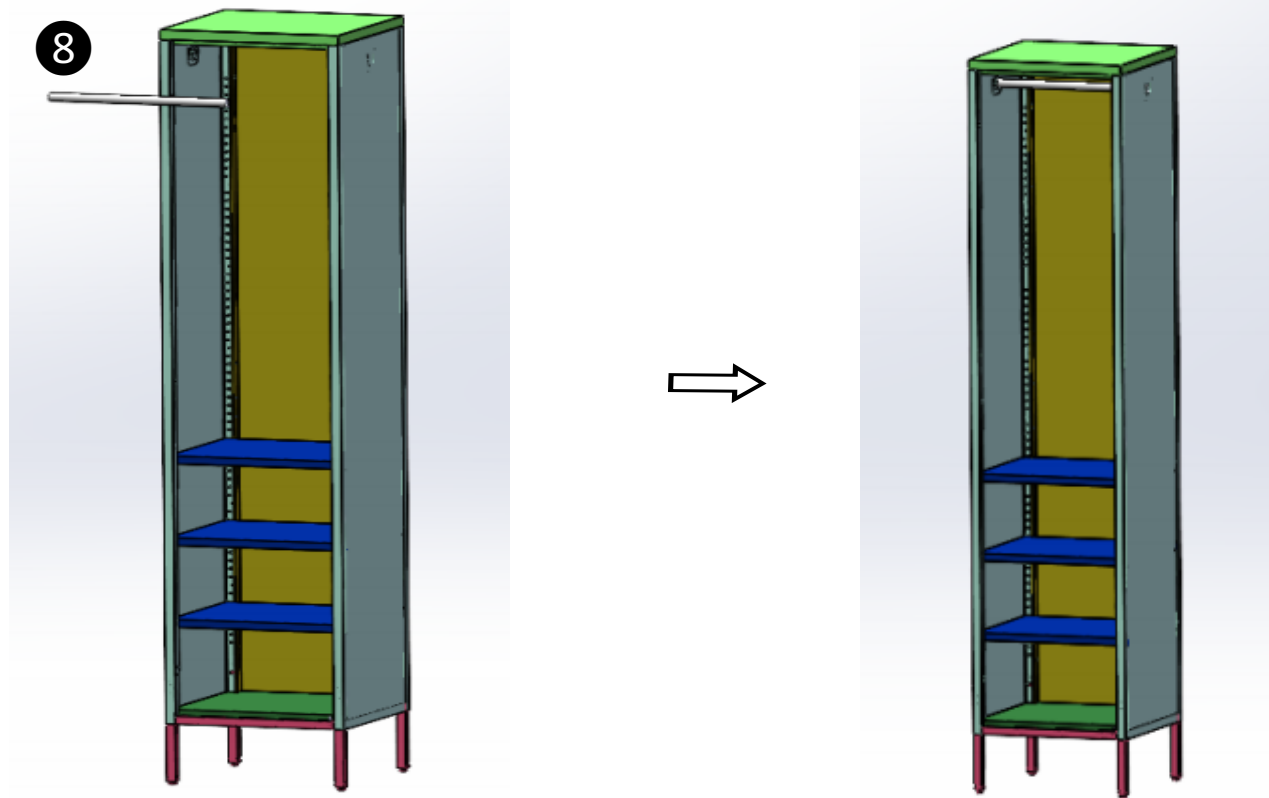

Assemble the handle on the door with 2 screws.

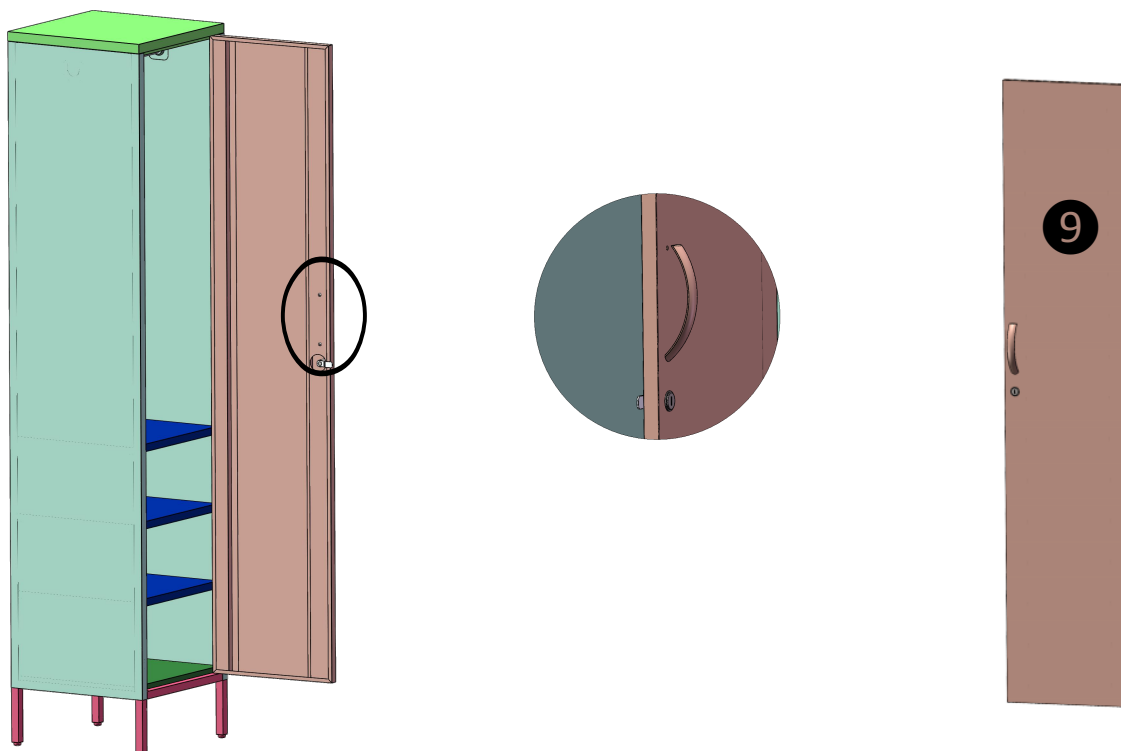

step 8 Insert the door hinges on the bottom and the spring clip on the top to assemble the door to finish the installation.

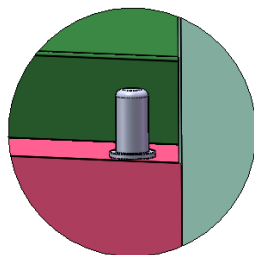
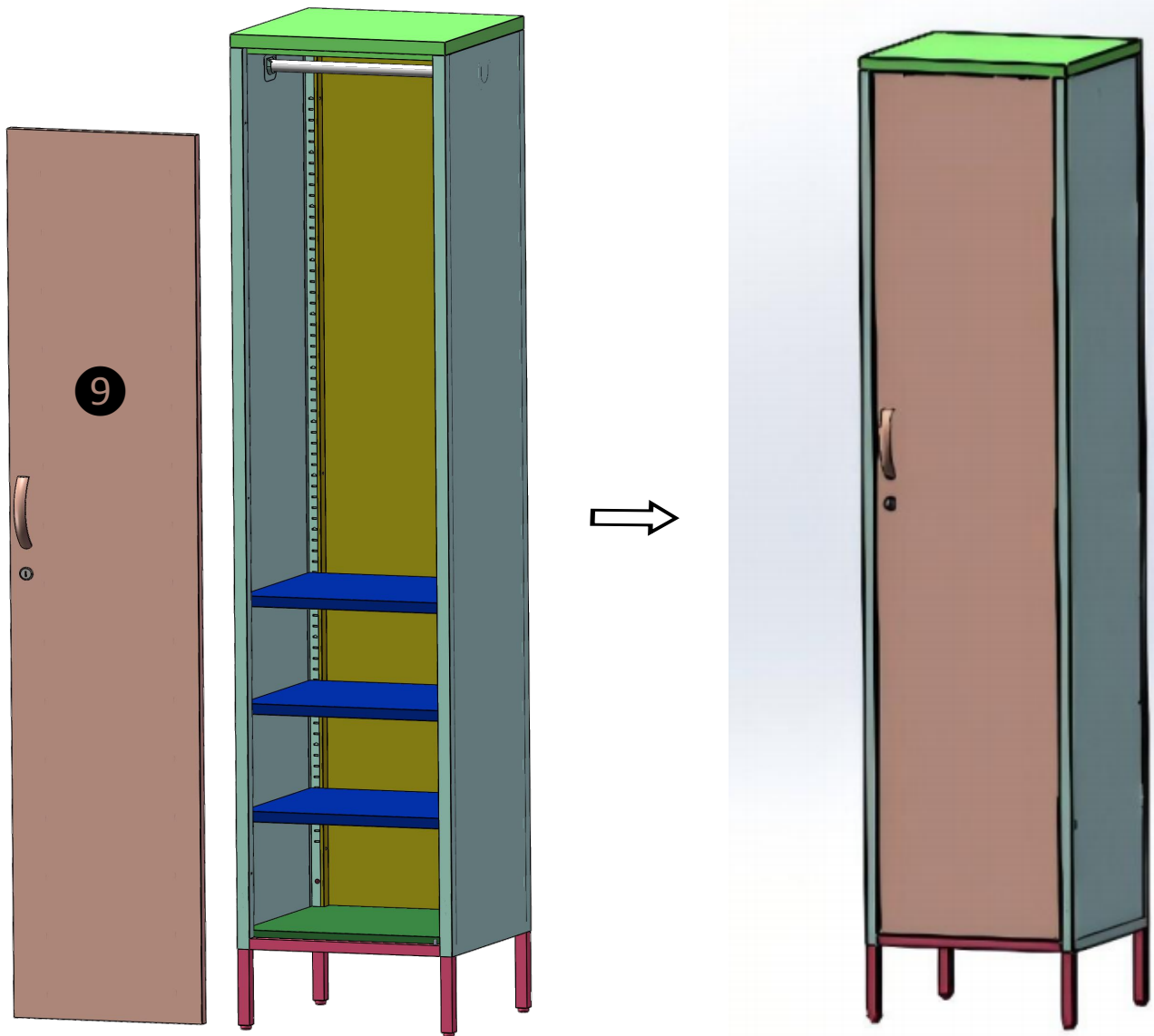

X1