

ASSEMBLY INSTRUCTIONS

Read this instruction carefully. See hardware and furniture part list for guidance. Be sure all parts are complete, before you assemble. Place all wooden furniture parts on a clean and flat soft surface to prevent from being scratched. Follow the figure to start assembling.

CAUTIONS : 1. Do not FULLY - TIGHTEN the nut or nut bolt until all nut or bolt is ready assembled.
2. Do not OVER - TIGHTEN the nut or bolt to avoid causing damages to the thread.
3. Keep all hardware parts out of reach of children.

PART LIST		
ITEM	DESCRIPTION	QTY
A	CUSHION SEAT	1pc
B	FRONT STRETCHER	1pc
C	BACK STRETCHER	1pc
D	LEG	2pcs

HARDWARE LIST		
ITEM	DESCRIPTION	QTY
1	JCBB Bolt M8 x 50mm 	4pcs
2	Wood Screw M4 x 38mm 	10pcs
3	M8 Spring Washer 	4pcs
4	Wood Dowel M10 x 30mm 	5pcs
5	M5 Allen Key (Ball Shape) 	1pc

NOTE : THE LIST AND QUANTITY SHOWN ARE FOR 1 UNIT ASSEMBLY.

Tool needed : Screwdriver & Hammer (not provided).

STEP 1

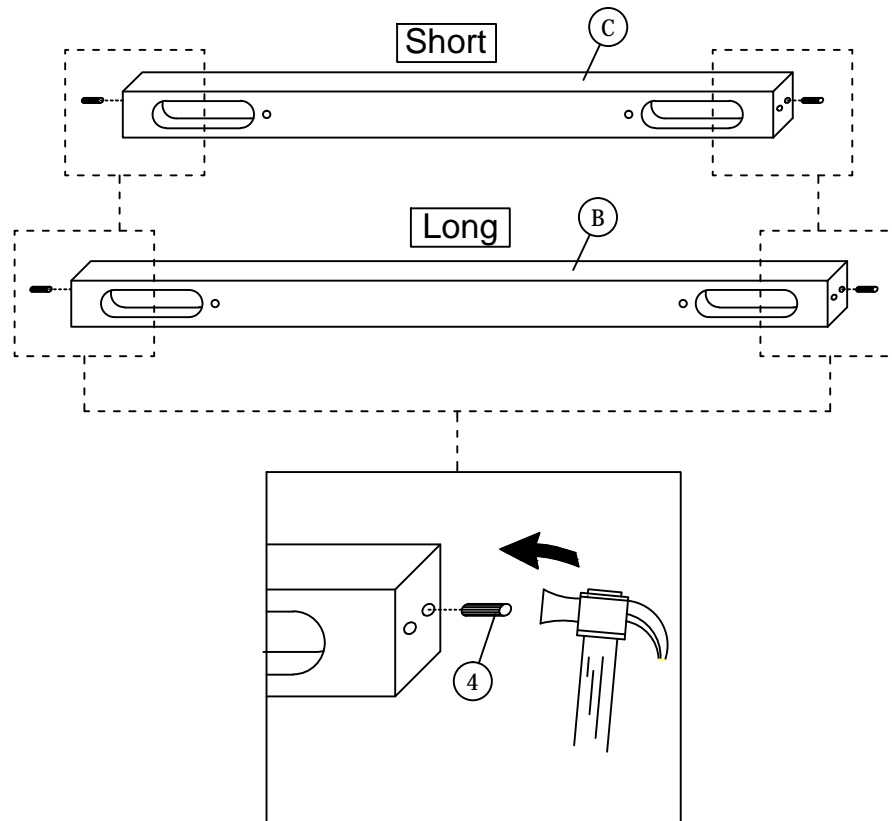

STEP 2

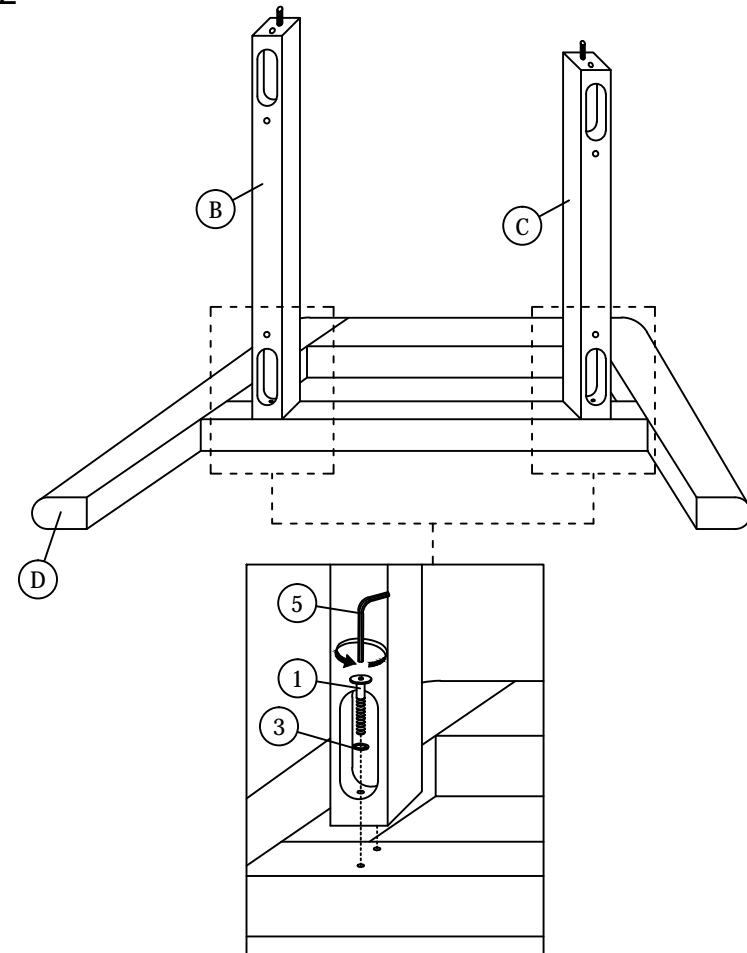

ASSEMBLY INSTRUCTIONS

STEP 3

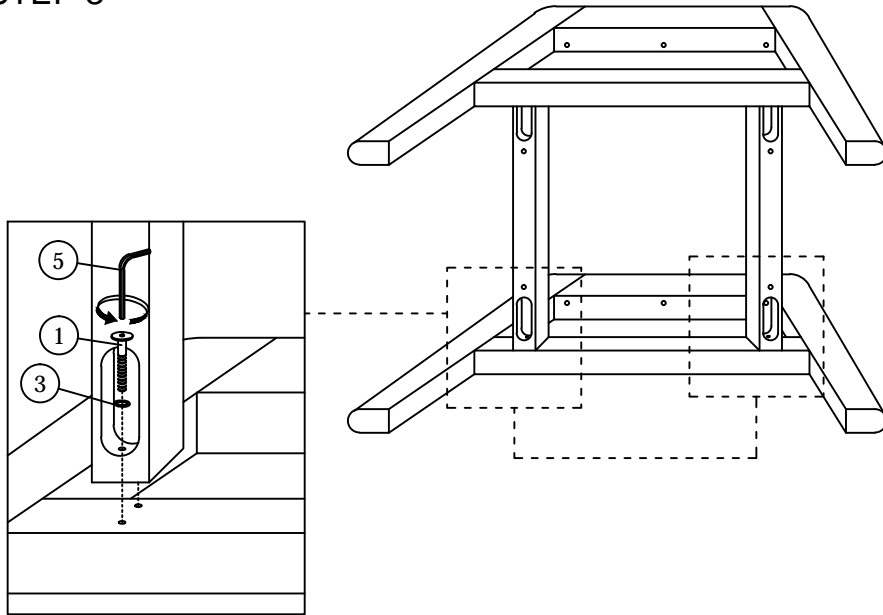

STEP 4

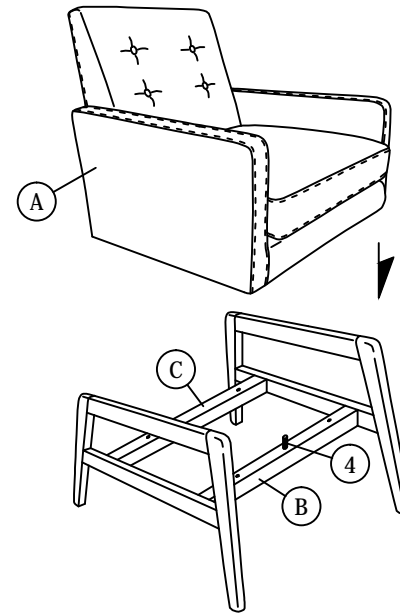

STEP 5

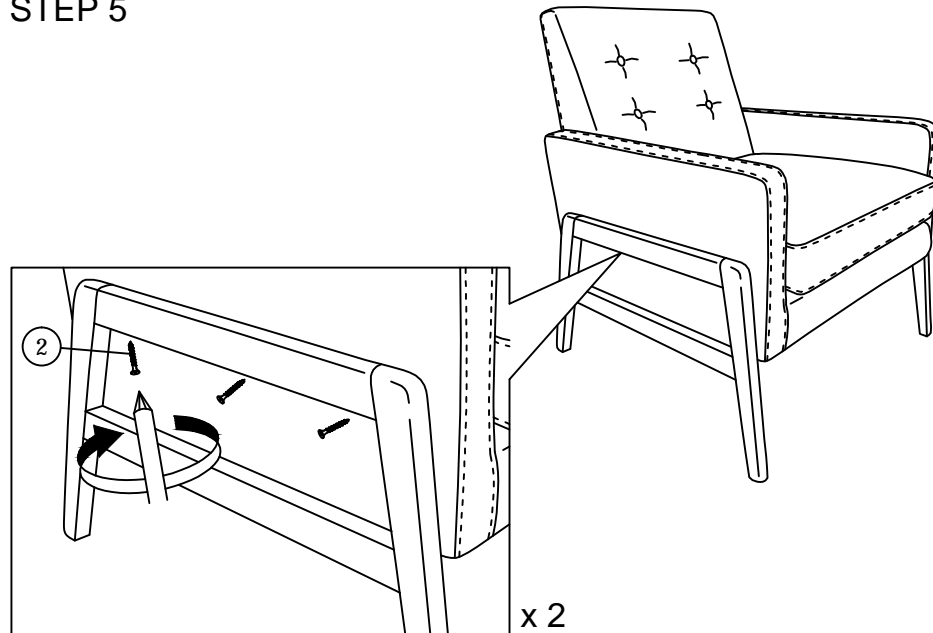

STEP 6

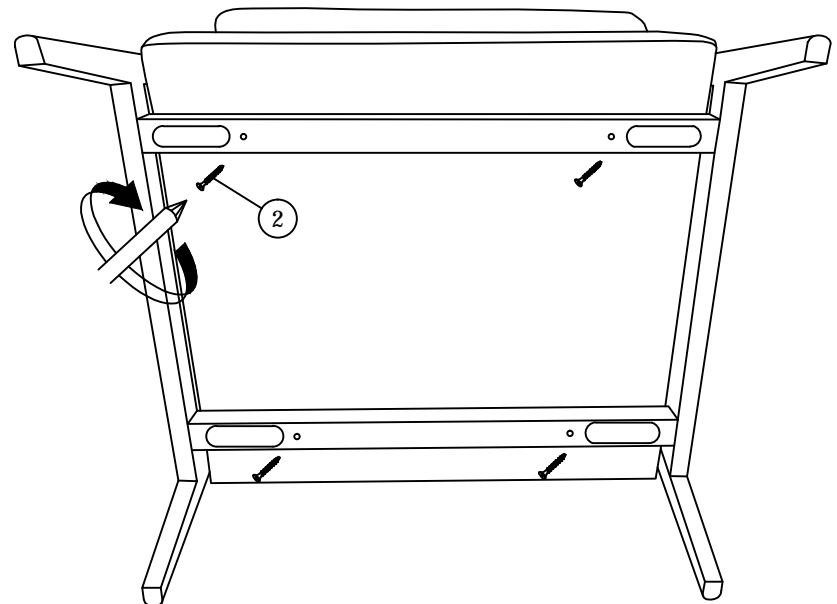

ASSEMBLY INSTRUCTIONS

STEP 7

