

Kitchen Island Card

Assembly instructions-Please keep for future reference

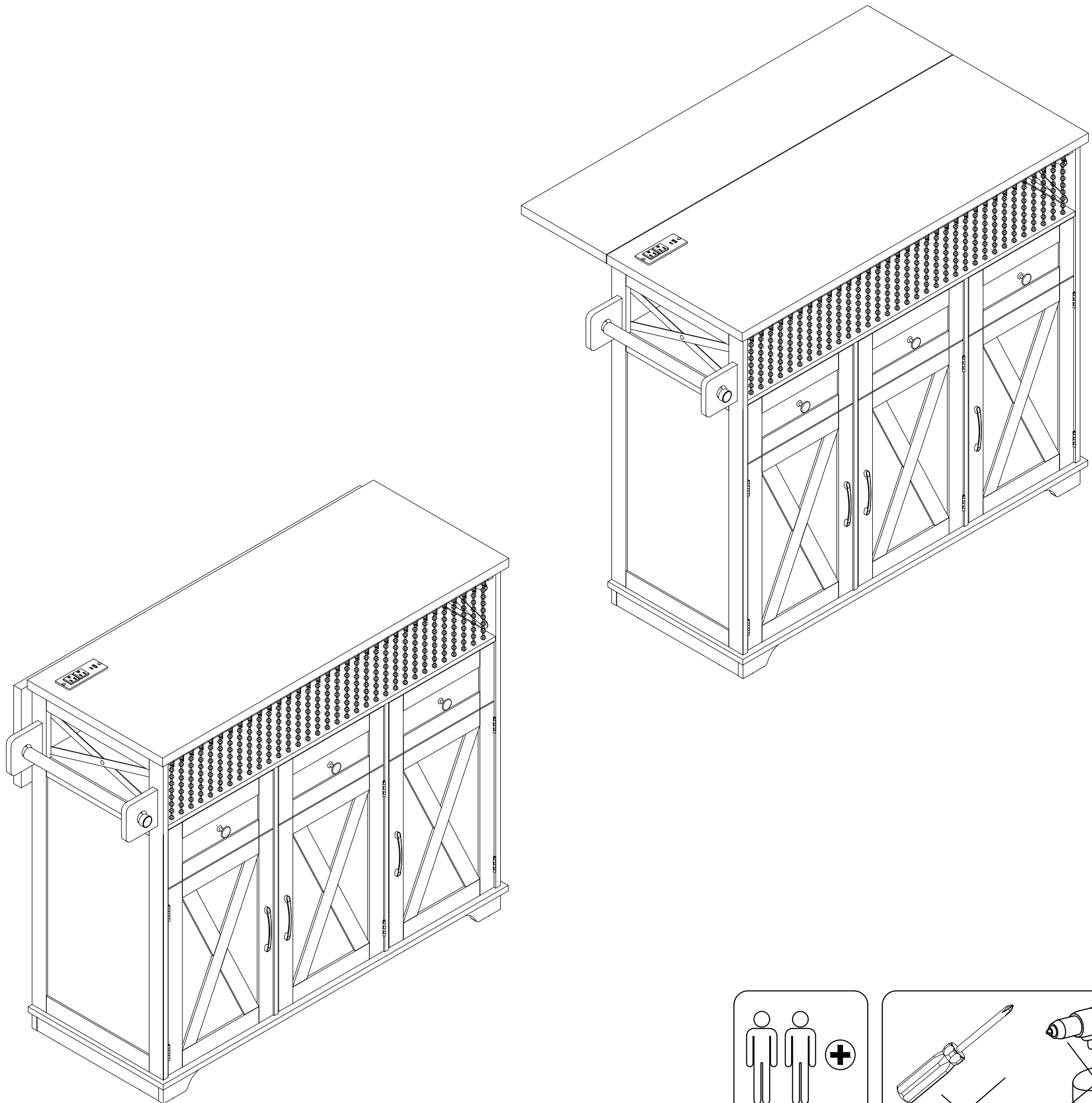

Important-Please read these instructions fully before starting assembly

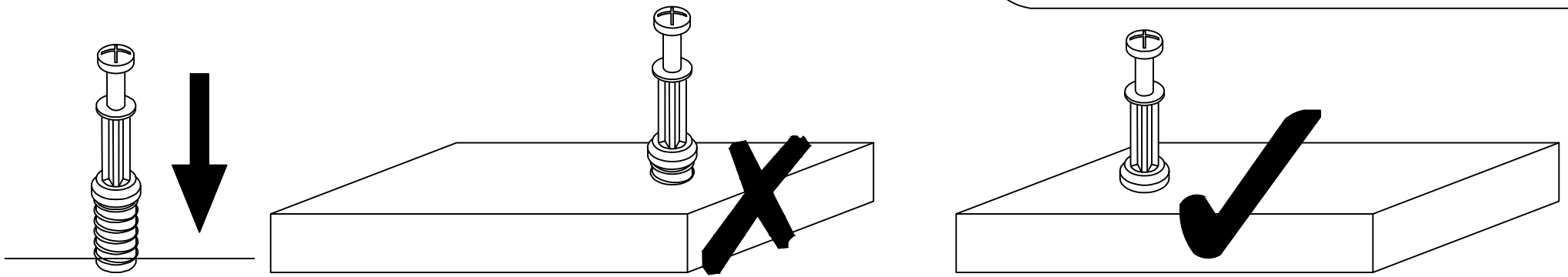

QUICKFIT: Tighten quickfit until shoulder is flush with panel. Do not overtighten or undertighten.

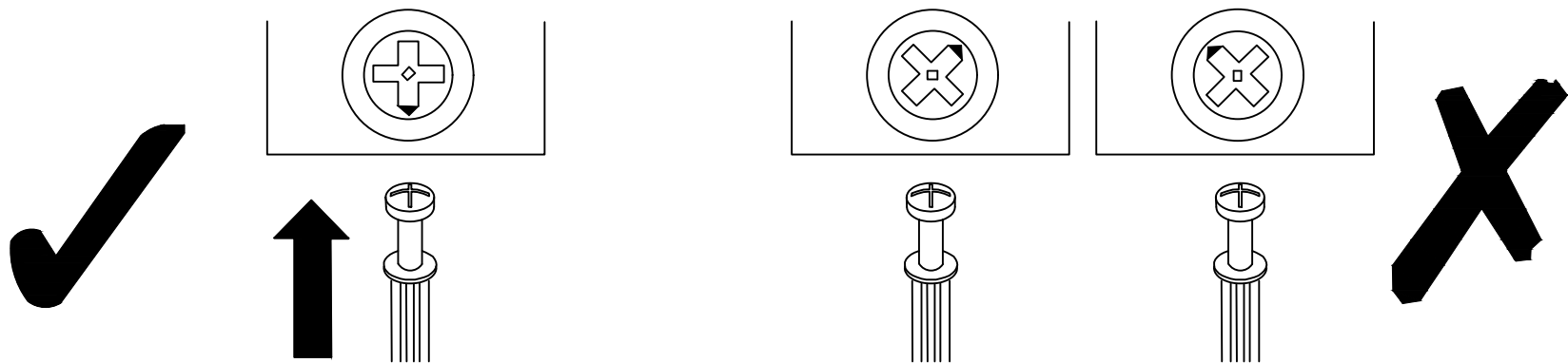

LOCK: When fitting cam lock, ensure starting position is correct before you insert connecting quickfit.

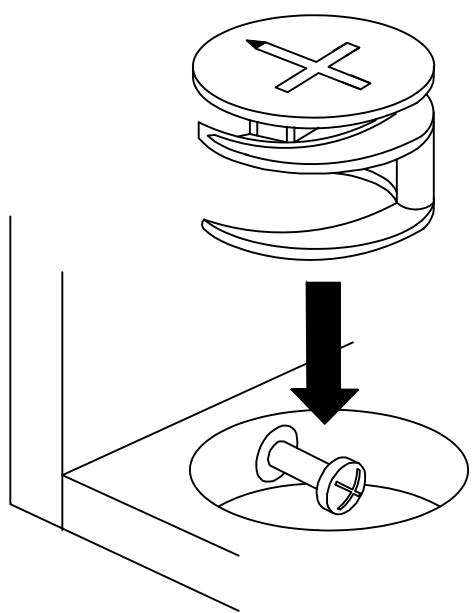

Quickfit head should be in the centre of the cam lock when the two panels are joined. Cam lock should be inserted before quickfit.

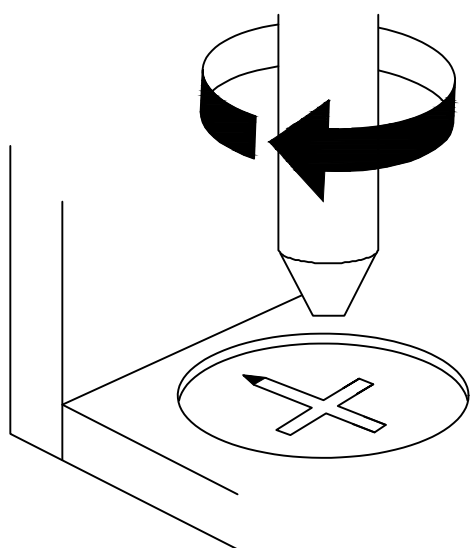

Turn cam lock clockwise to tighten.

Assembly Instructions

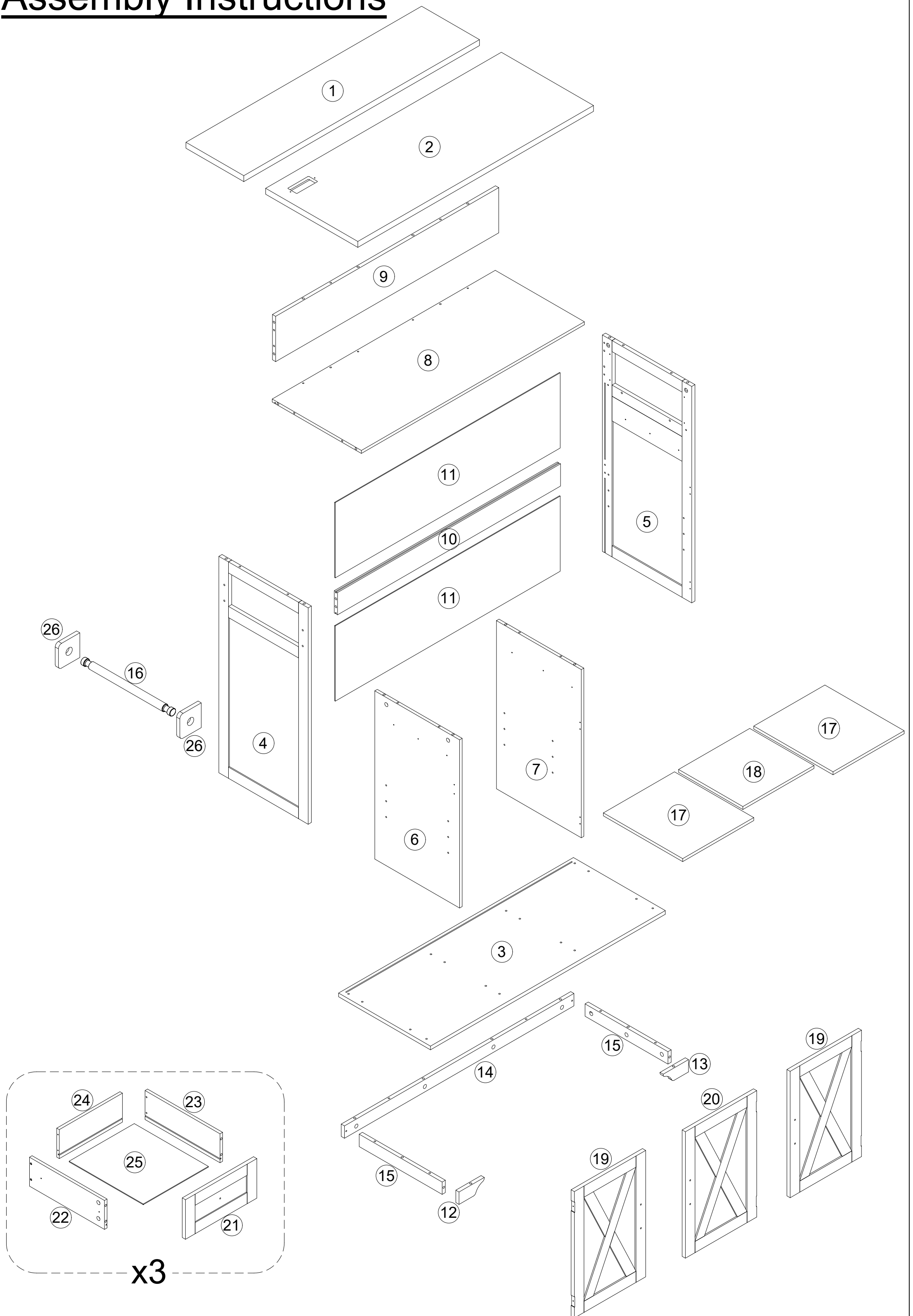



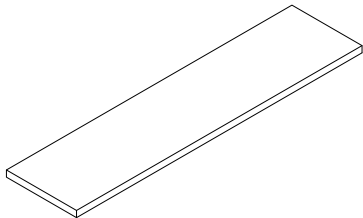
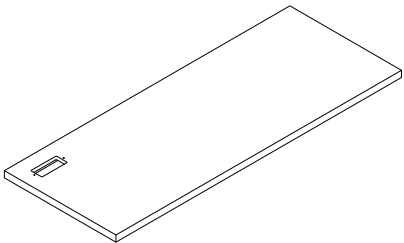
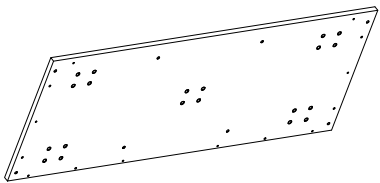
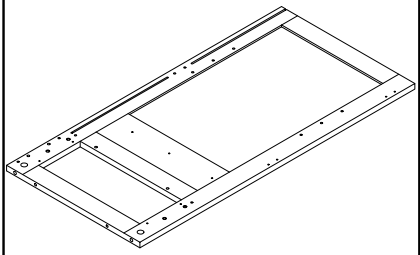
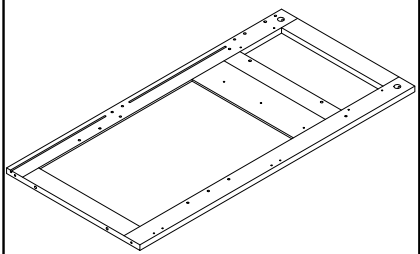
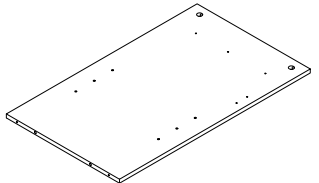
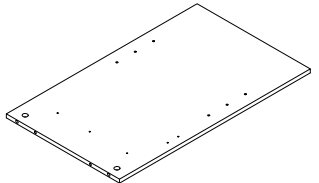
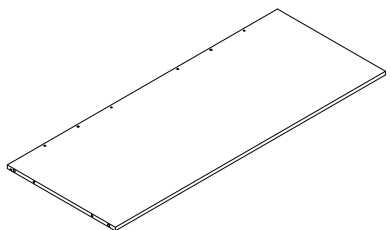
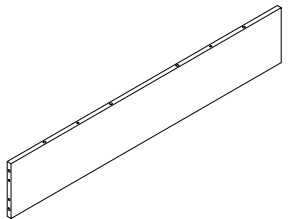
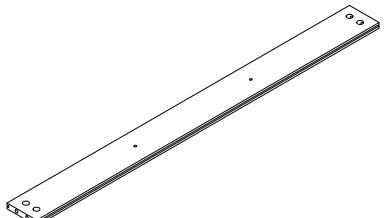

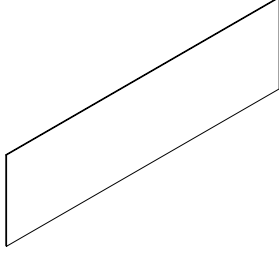
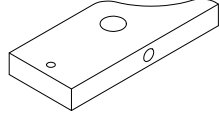
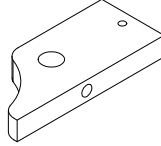
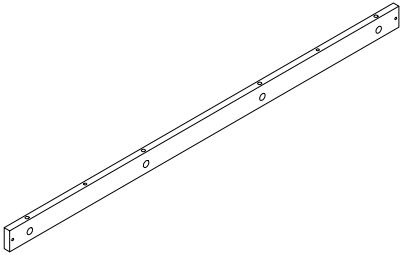
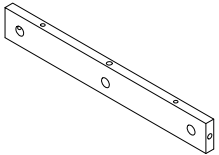
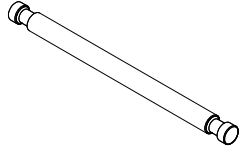
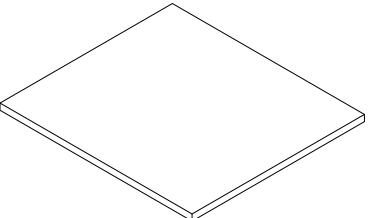
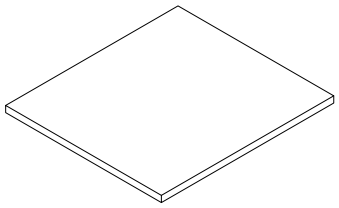
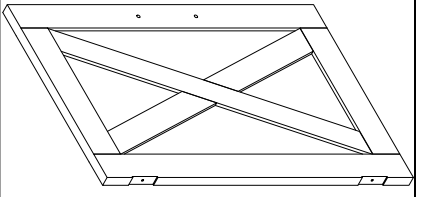
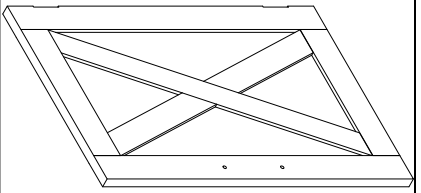

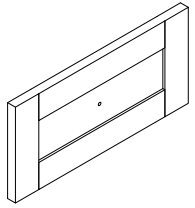
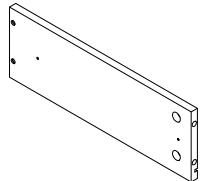
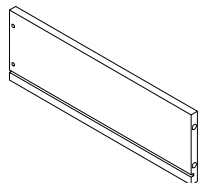
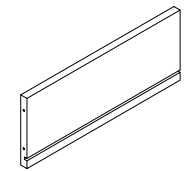
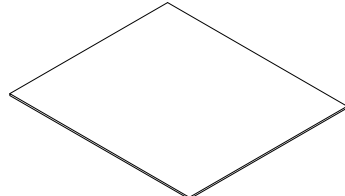
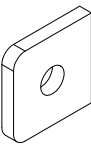



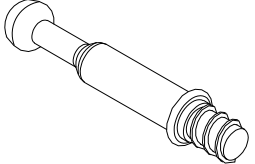
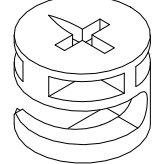

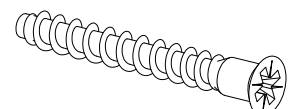
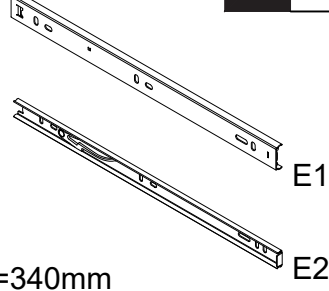
Parts List

NO.	PARTS	QTY
①		x1
②		x1
③		x1
④		x1
⑤		x1
⑥		x1
⑦		x1
⑧		x1
⑨		x1
⑩		x1

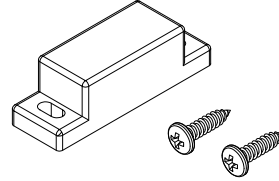
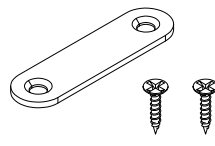
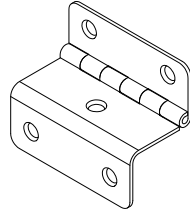
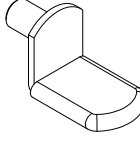
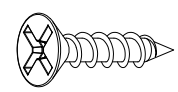
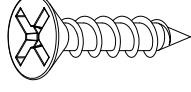
NO.	PARTS	QTY
⑪		x2
⑫		x1
⑬		x1
⑭		x1
⑮		x2
⑯		x1
⑰		x2
⑱		x1
⑲		x2
⑳		x1

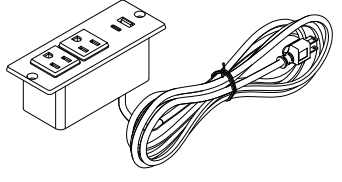
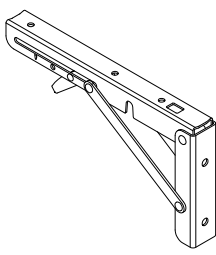
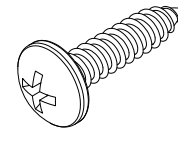
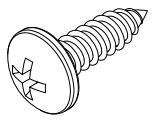
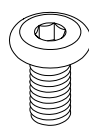
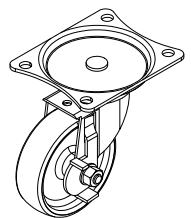
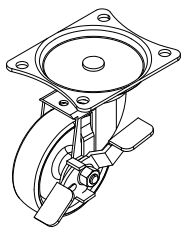
NO.	PARTS	QTY
⑳		x3
㉑		x3
㉒		x3
㉓		x3
㉔		x3
㉕		x2

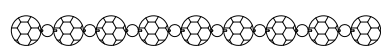
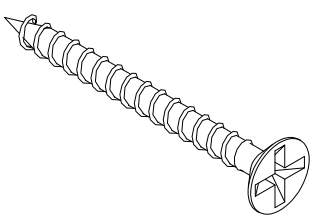
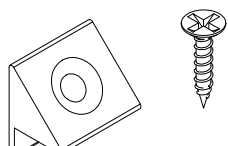
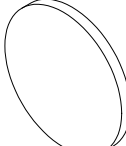
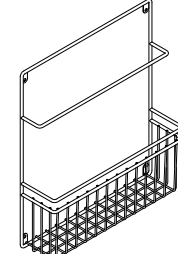
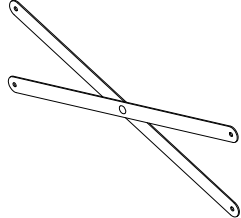
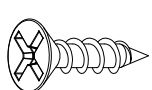
Hardware

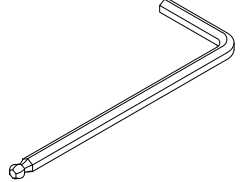
<p>A x52</p> 	<p>B x52</p> 	<p>C x34 6x30mm</p> 	<p>D x14 5x38mm</p> 	<p>E x6</p> 
<p>F x3</p> 	<p>G x3</p> 	<p>H x3 M4x10mm</p> 	<p>I x6 M4x16mm</p> 	<p>J x3 3x14mm</p> 
<p>K x3 3x10mm</p> 	<p>L x6</p> 	<p>M x12</p> 	<p>N x30 3x12mm</p> 	<p>O x34 3.5x12mm</p> 
<p>P x1</p> 	<p>Q x1</p> 	<p>R x3</p> 	<p>S x9 4x16mm</p> 	<p>T x12 4x12mm</p> 
<p>U x26 M6x10mm</p> 	<p>V x3</p> 	<p>W x2</p> 	<p>X x33</p> 	<p>Y x33</p> 
<p>Z x12 3.5x35mm</p> 	<p>AA x10 3x16mm</p> 	<p>BB x20</p> 	<p>CC x1</p> 	<p>DD x2</p> 
<p>EE x6 3x10mm</p> 				

Assembly Steps

1

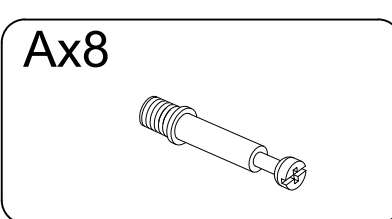
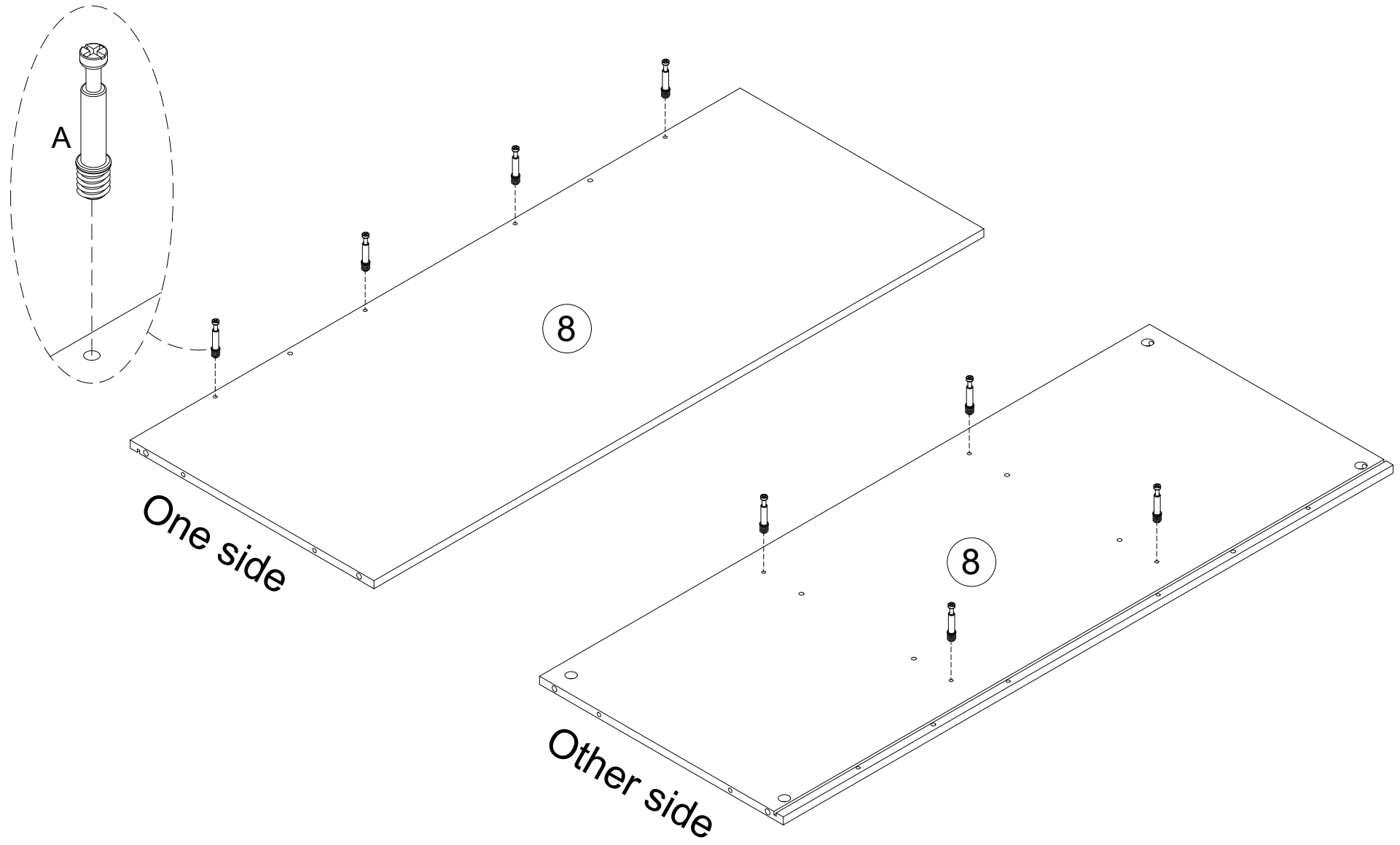

2

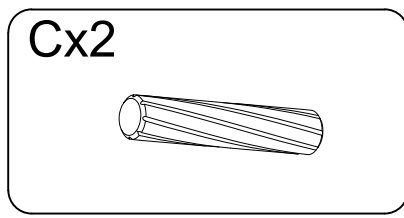
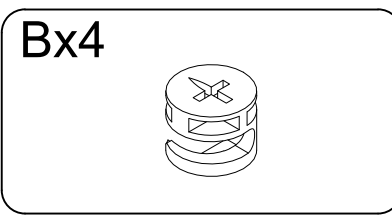
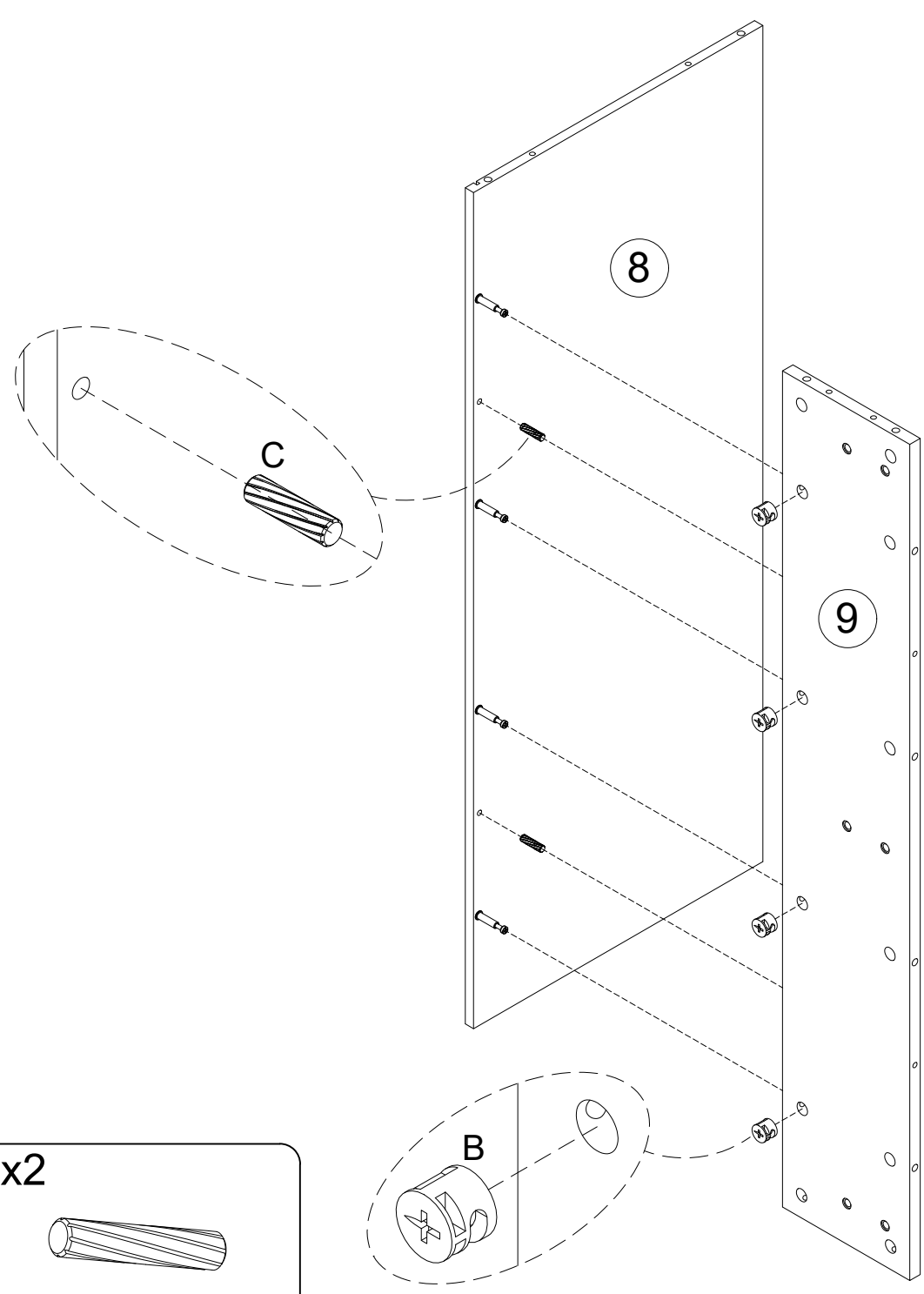

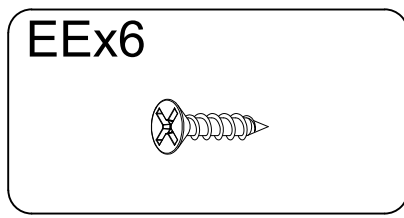
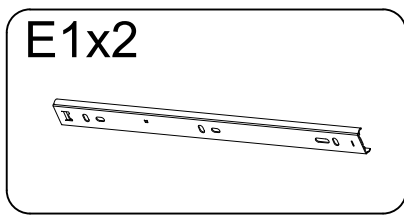
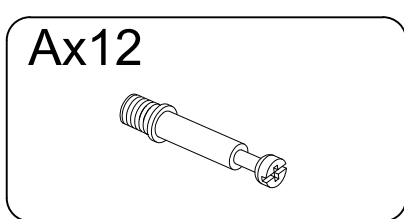
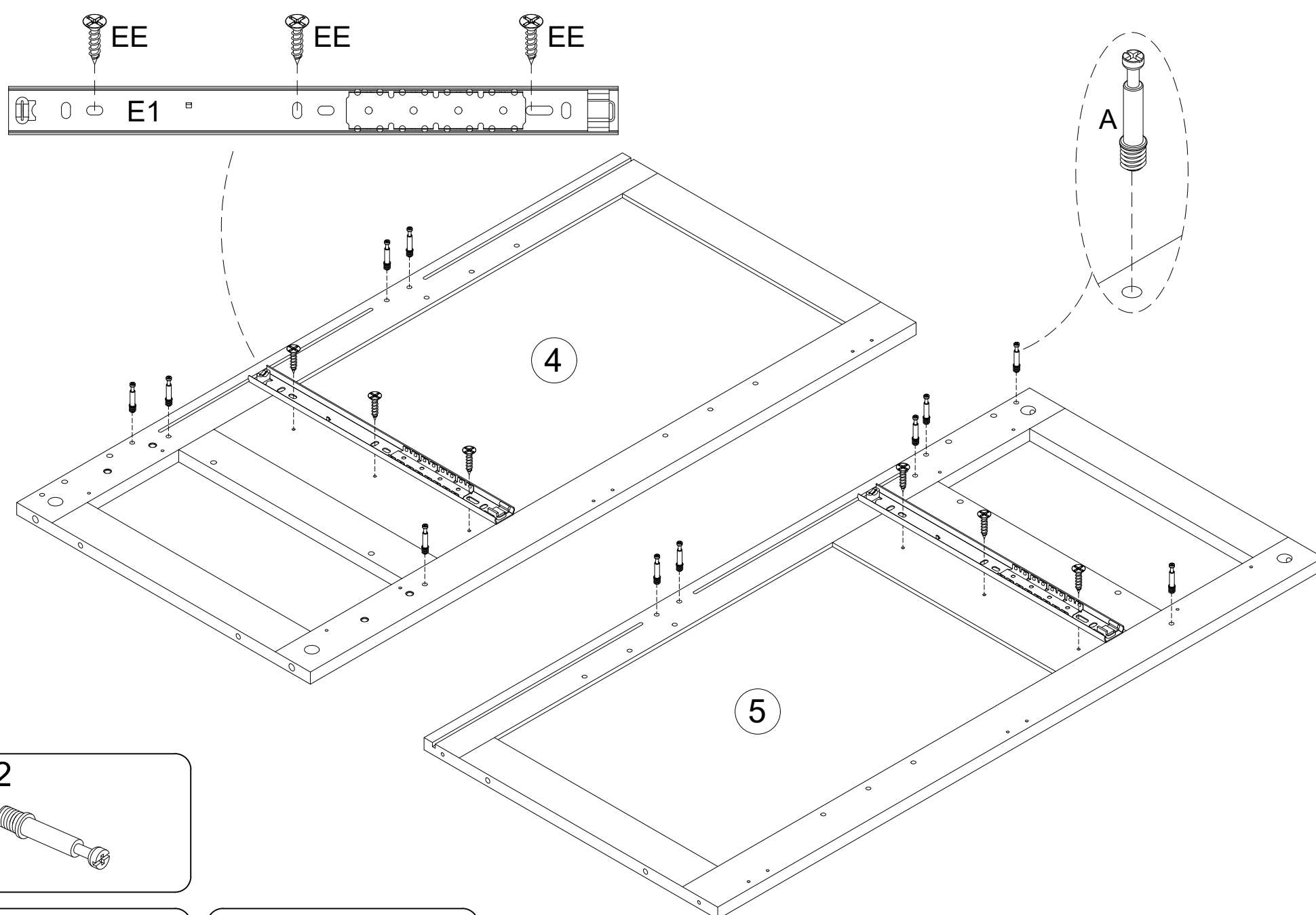
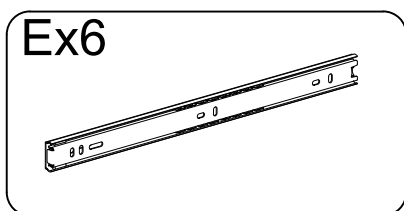
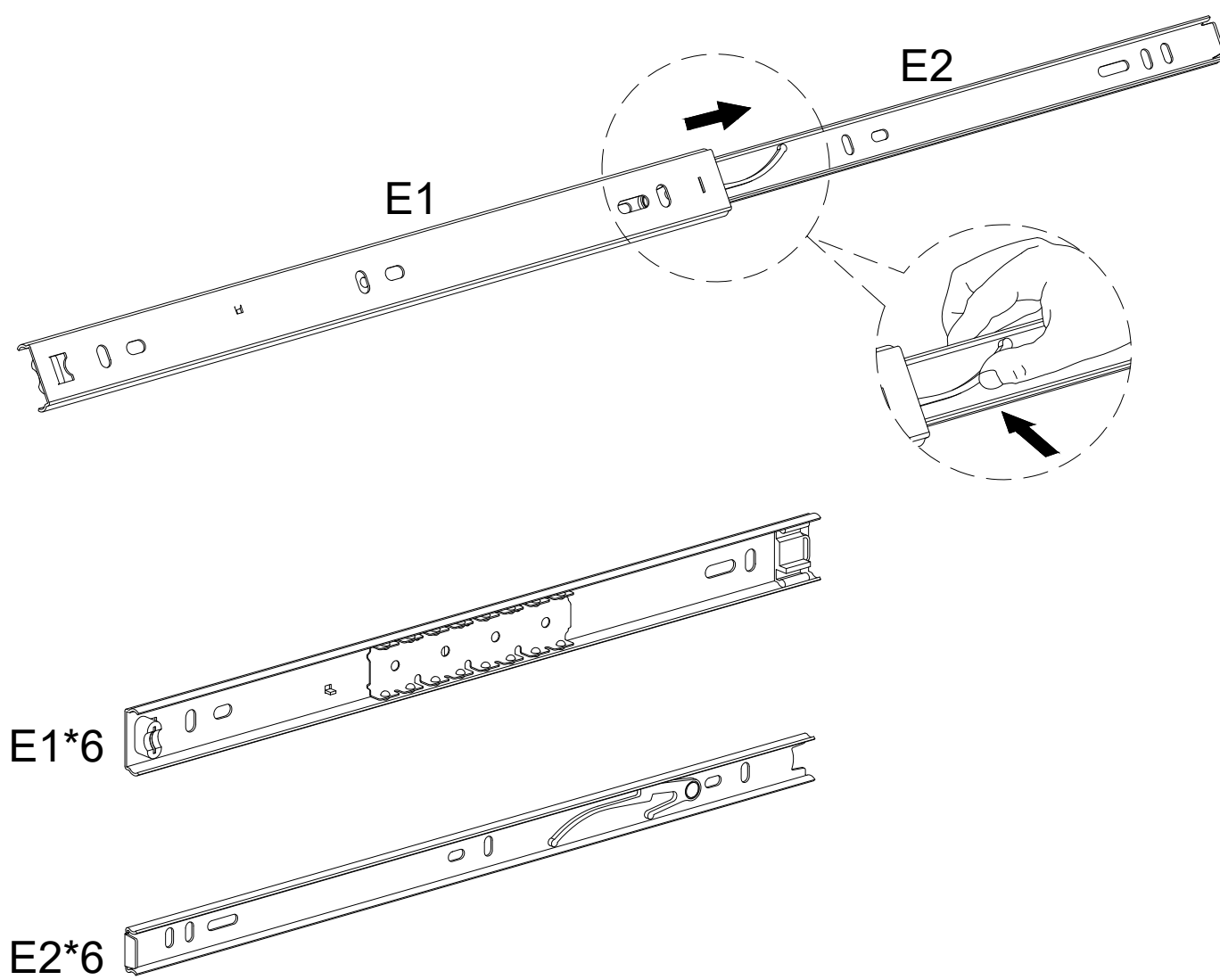

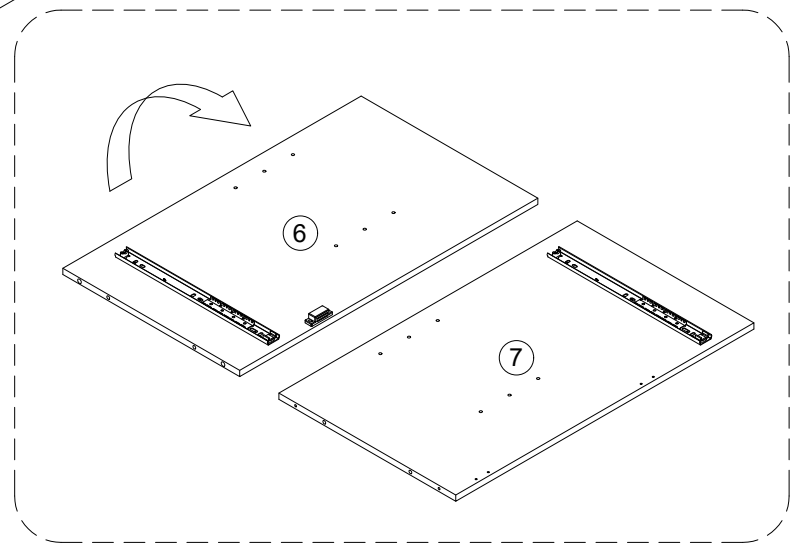
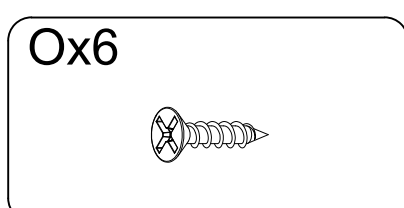
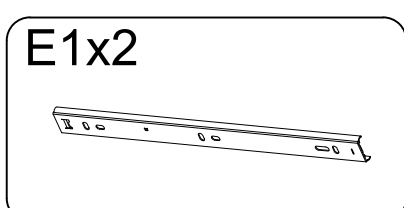
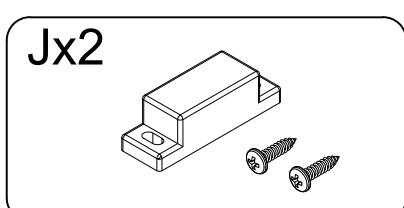
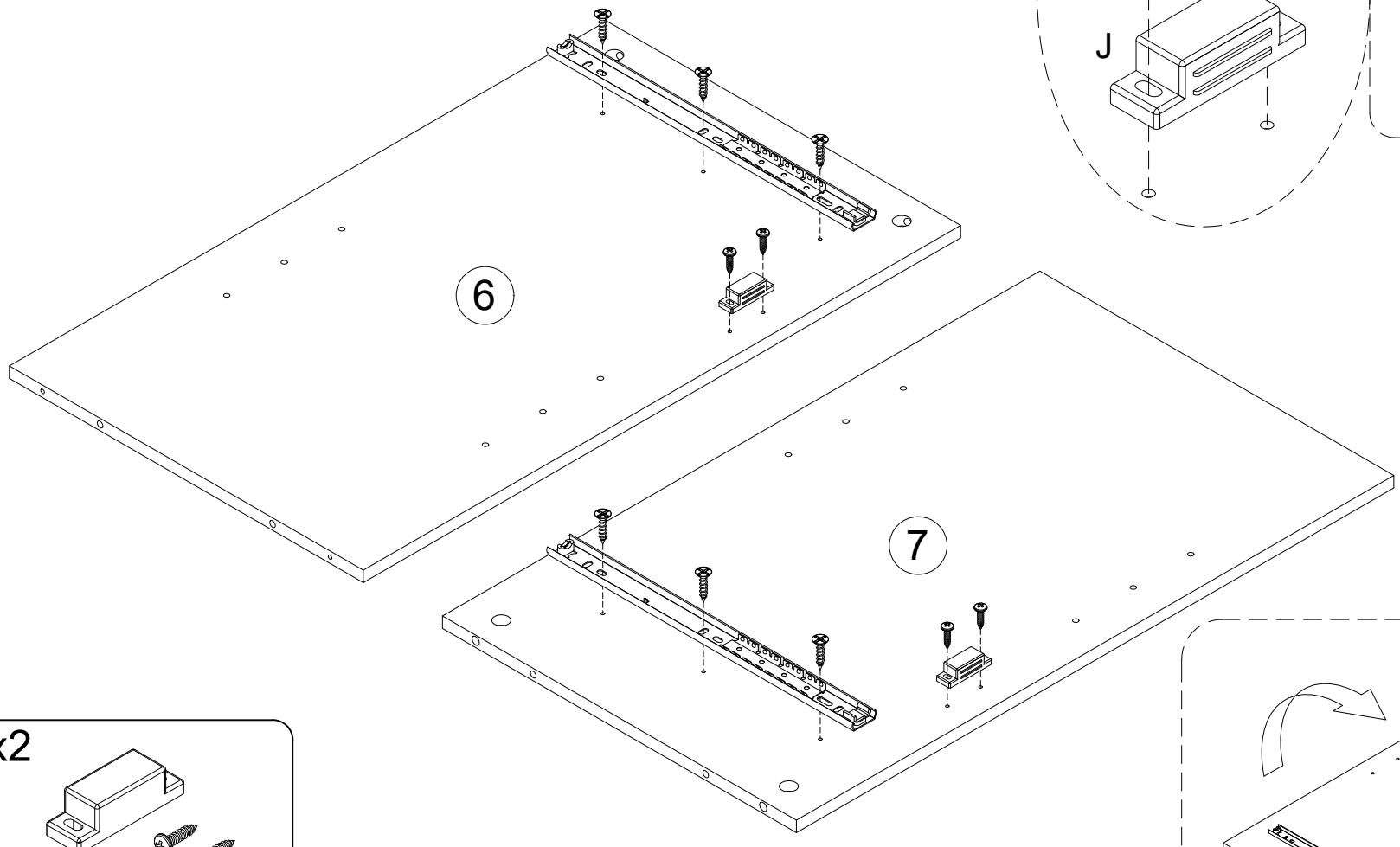
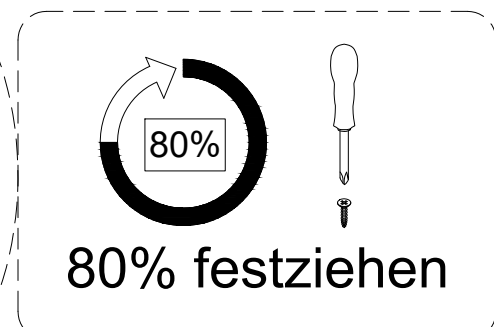
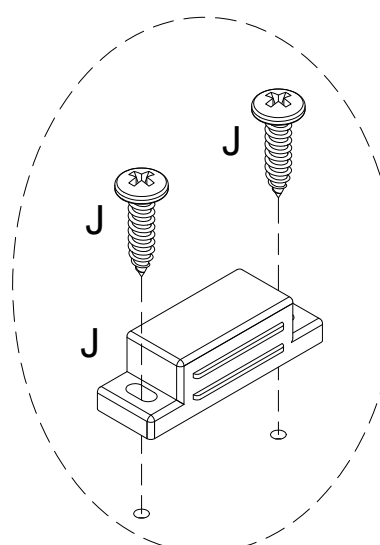
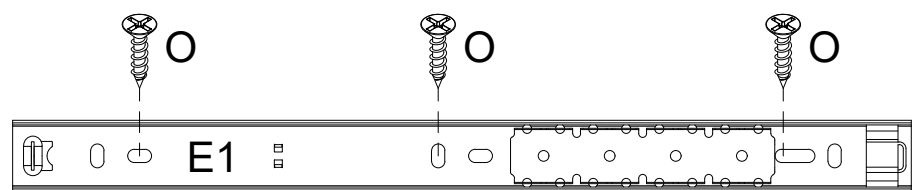
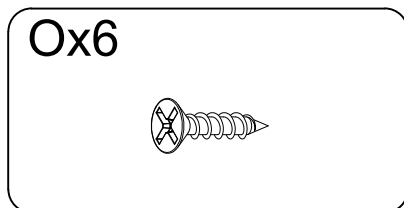
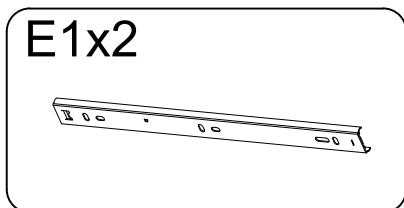
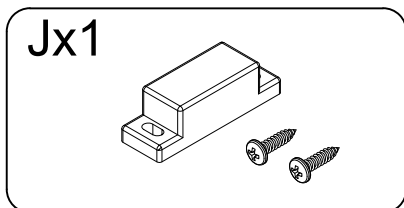
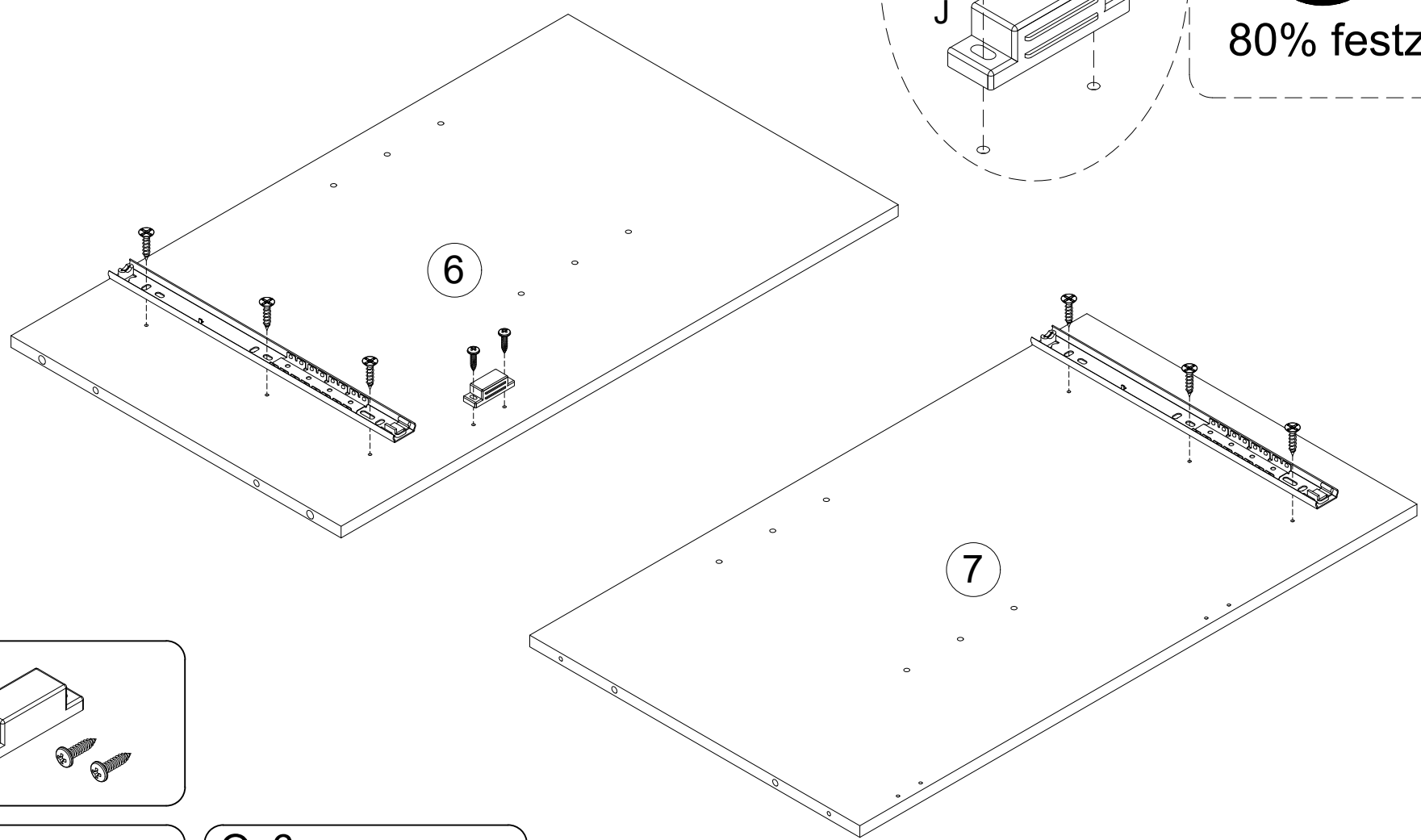
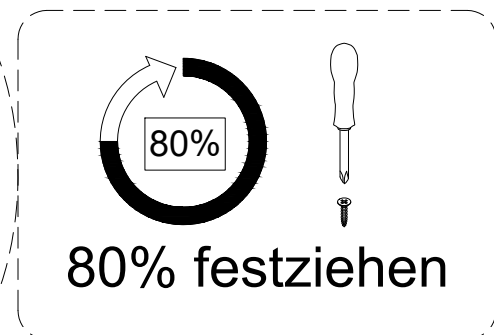
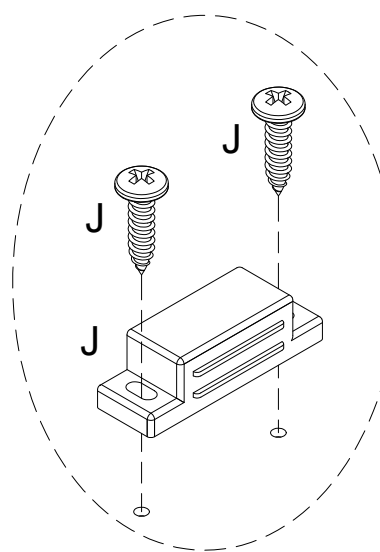
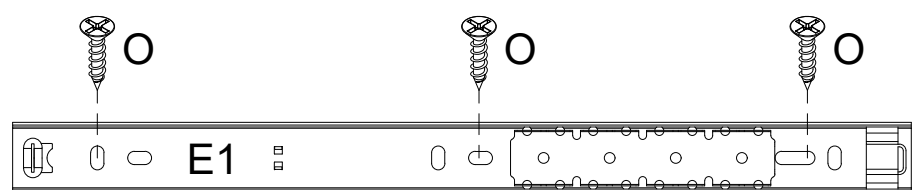

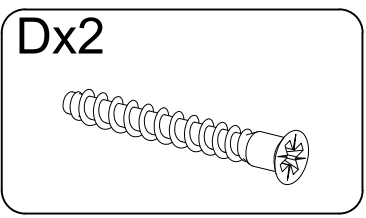
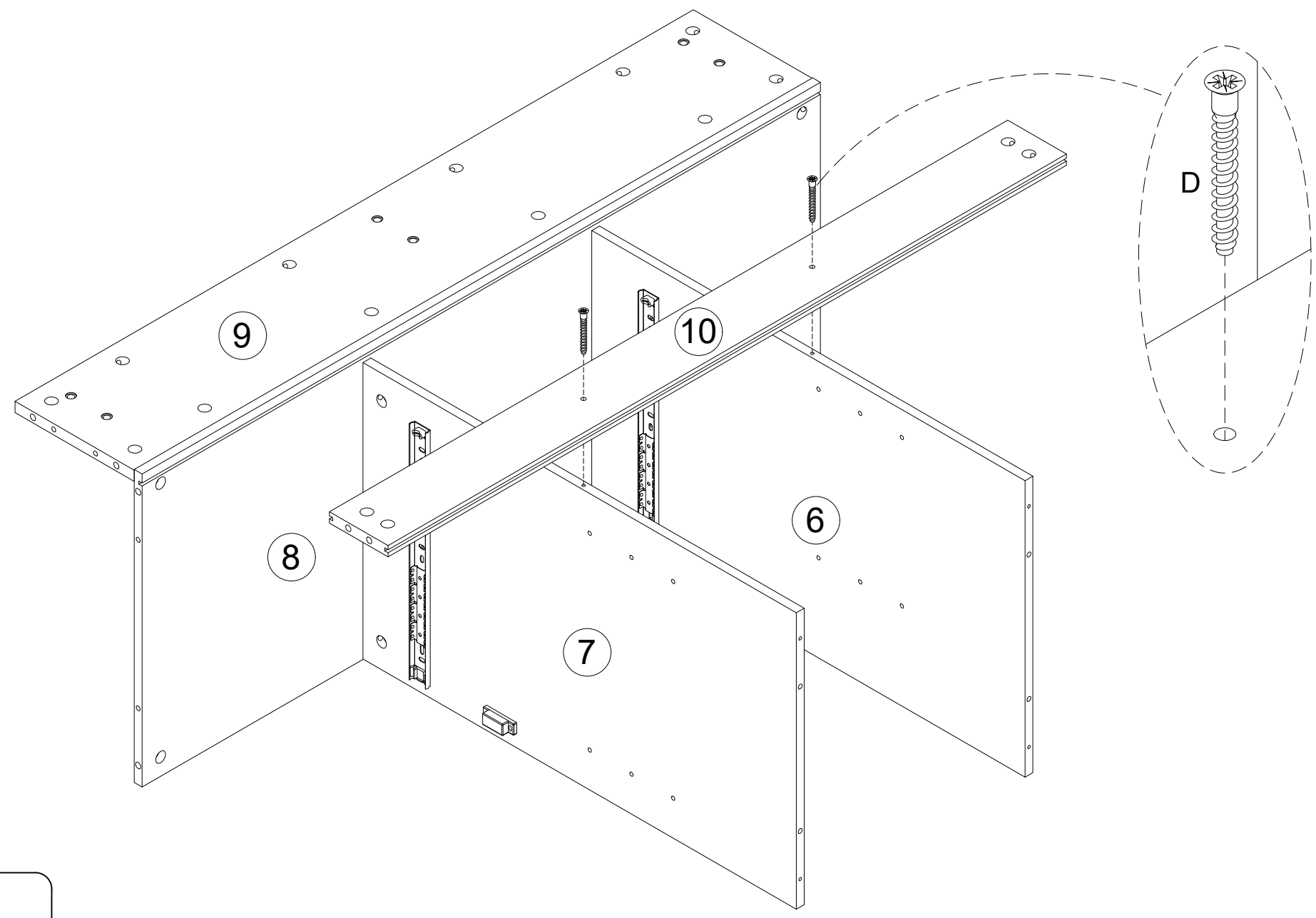
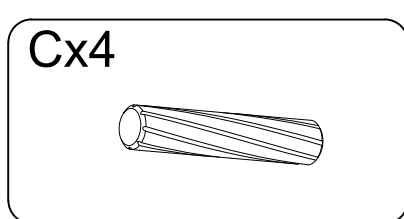
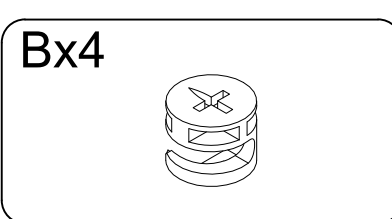
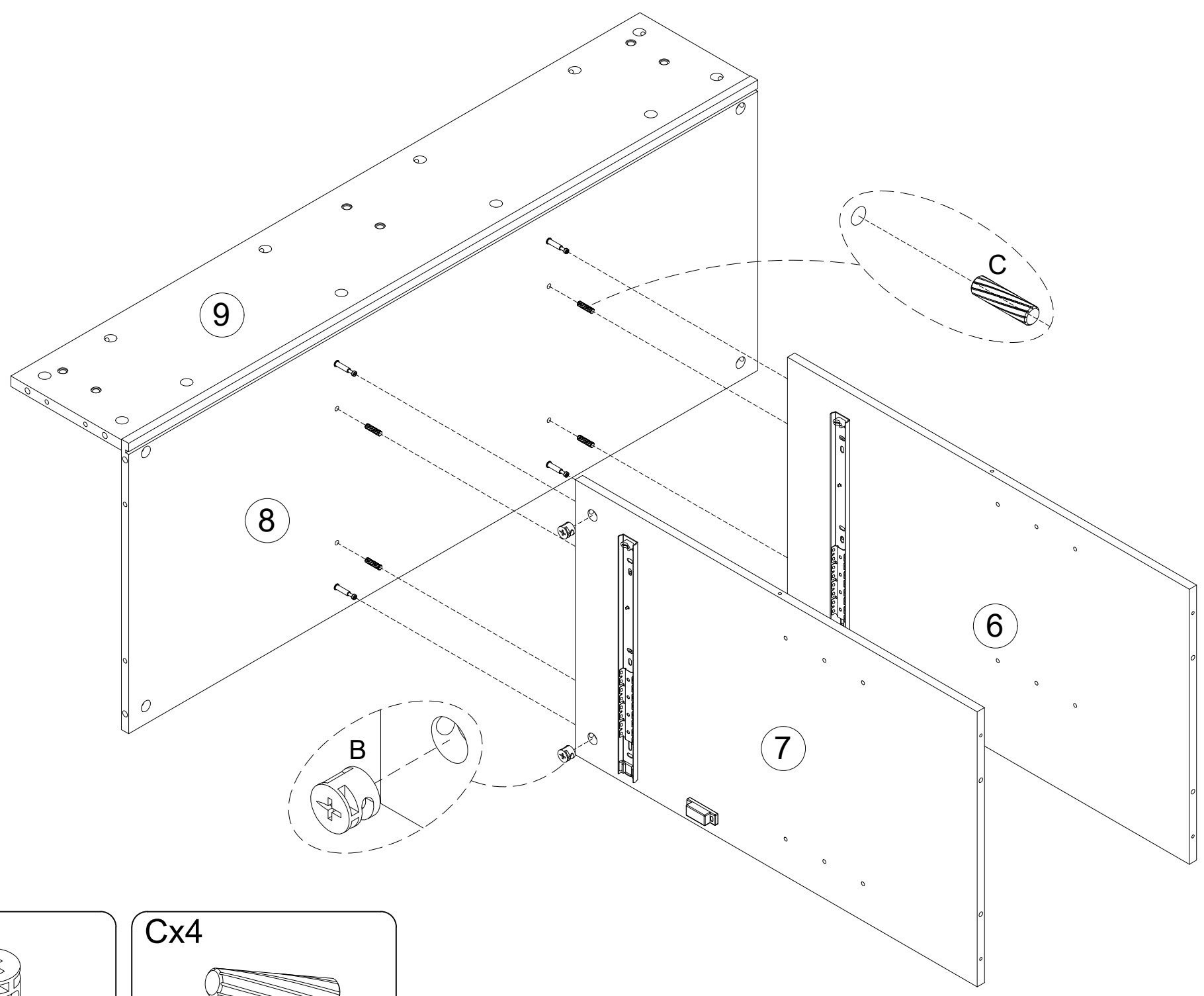

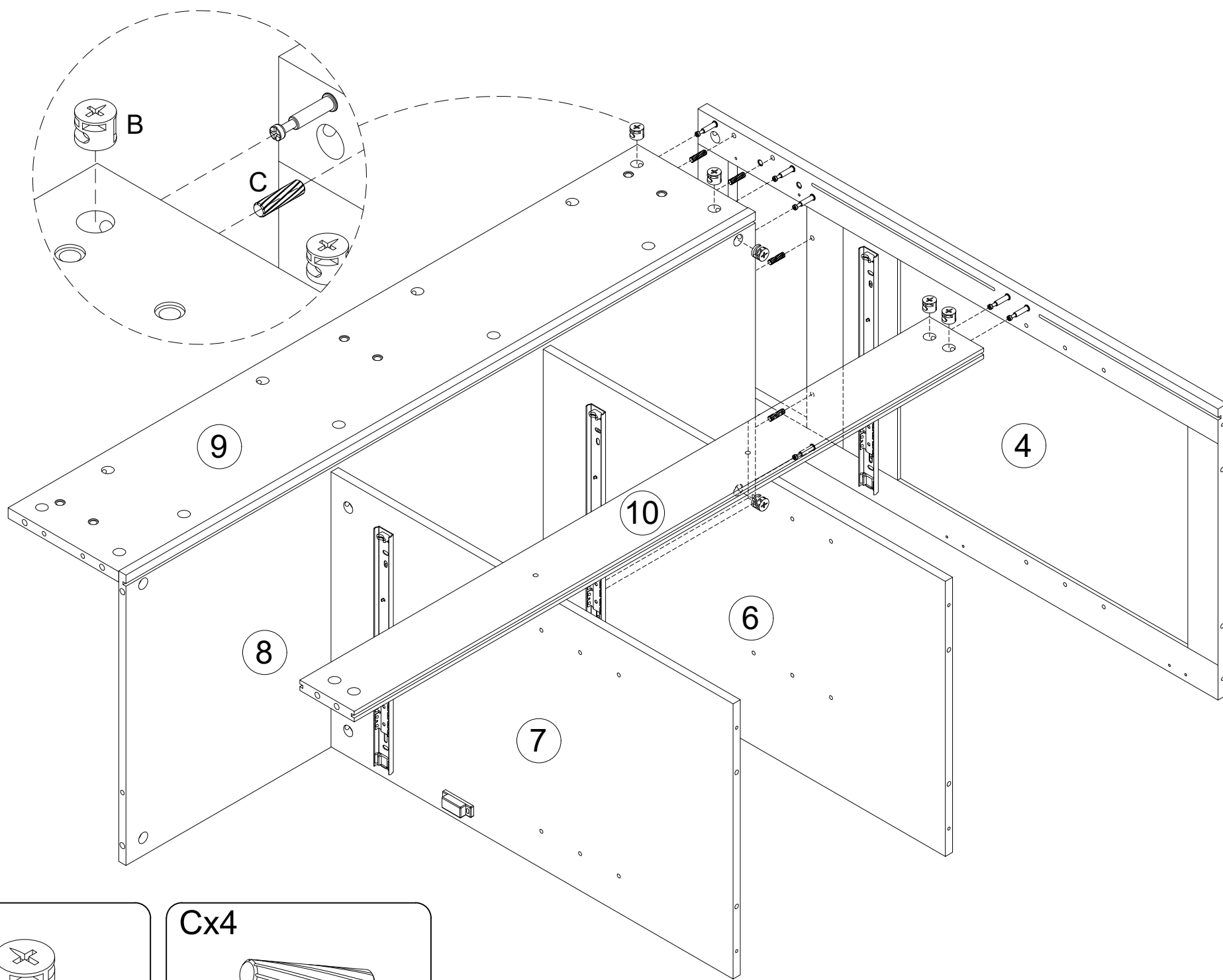

Bx6

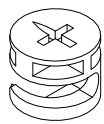

Cx4

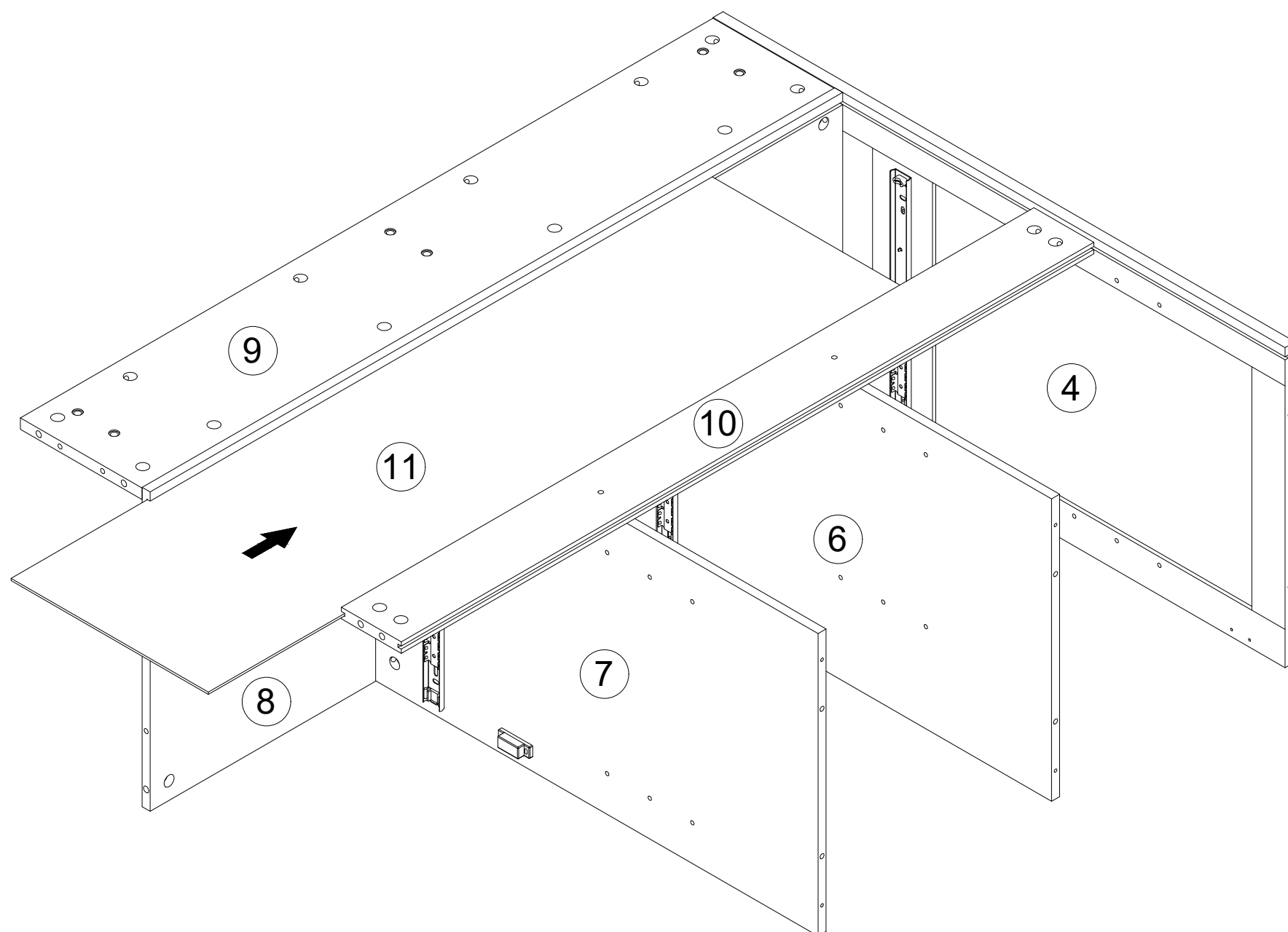

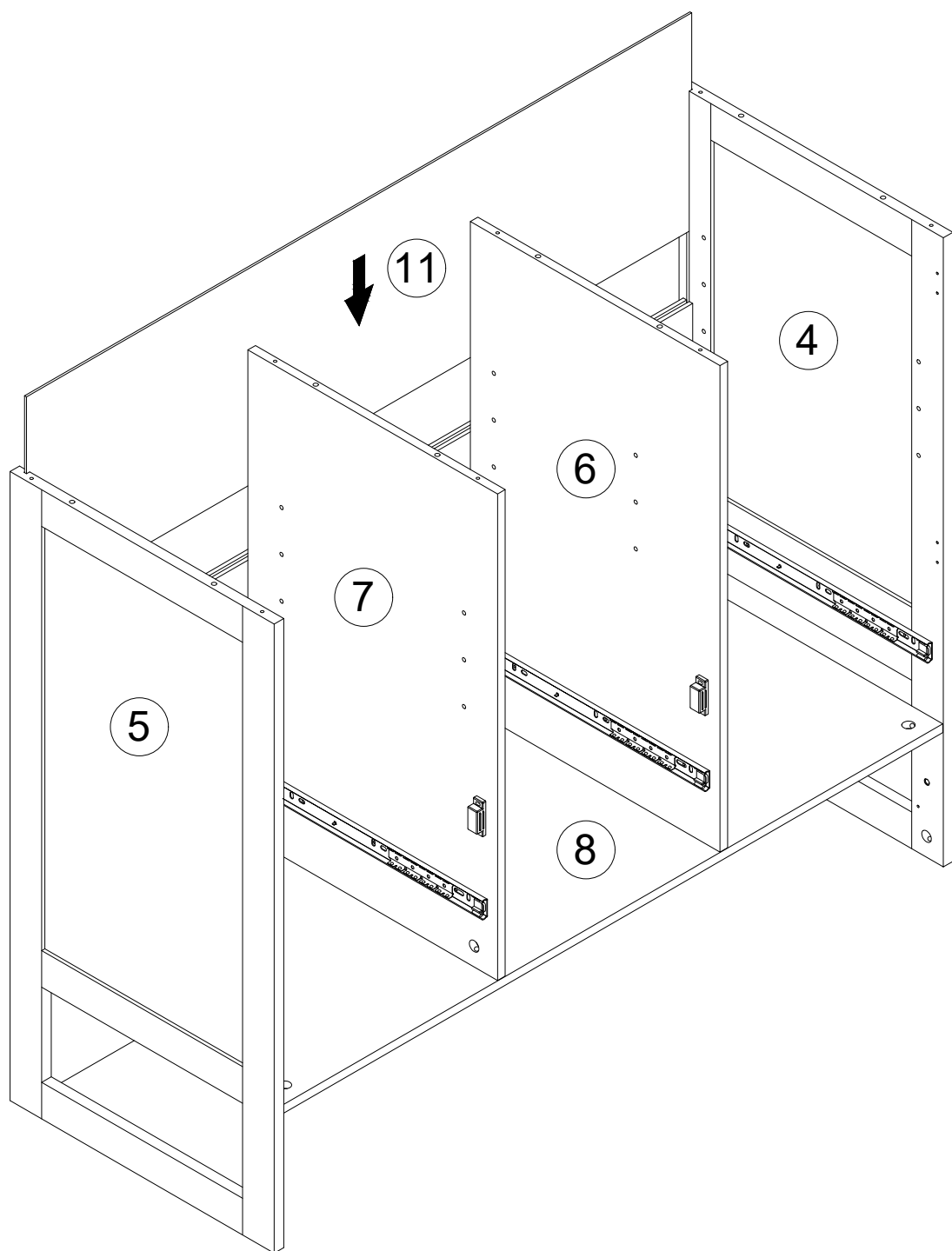
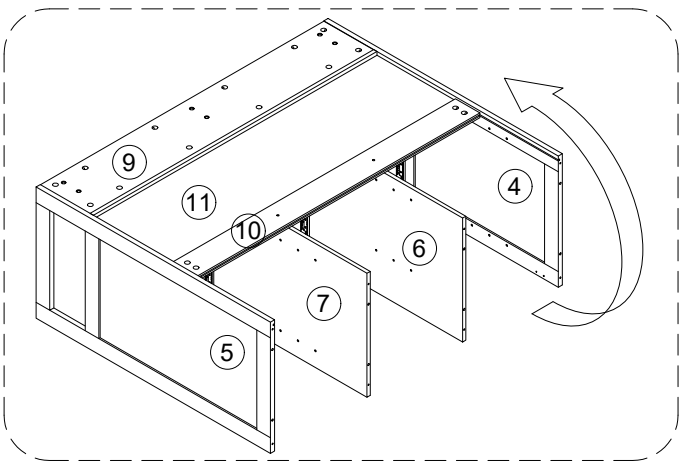
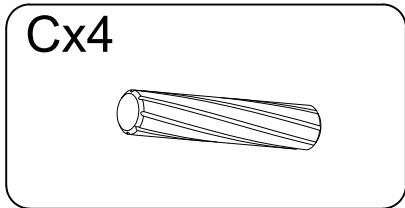
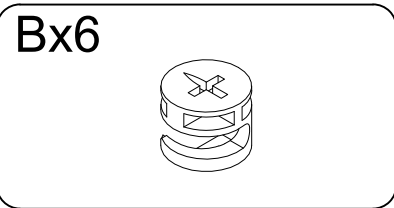
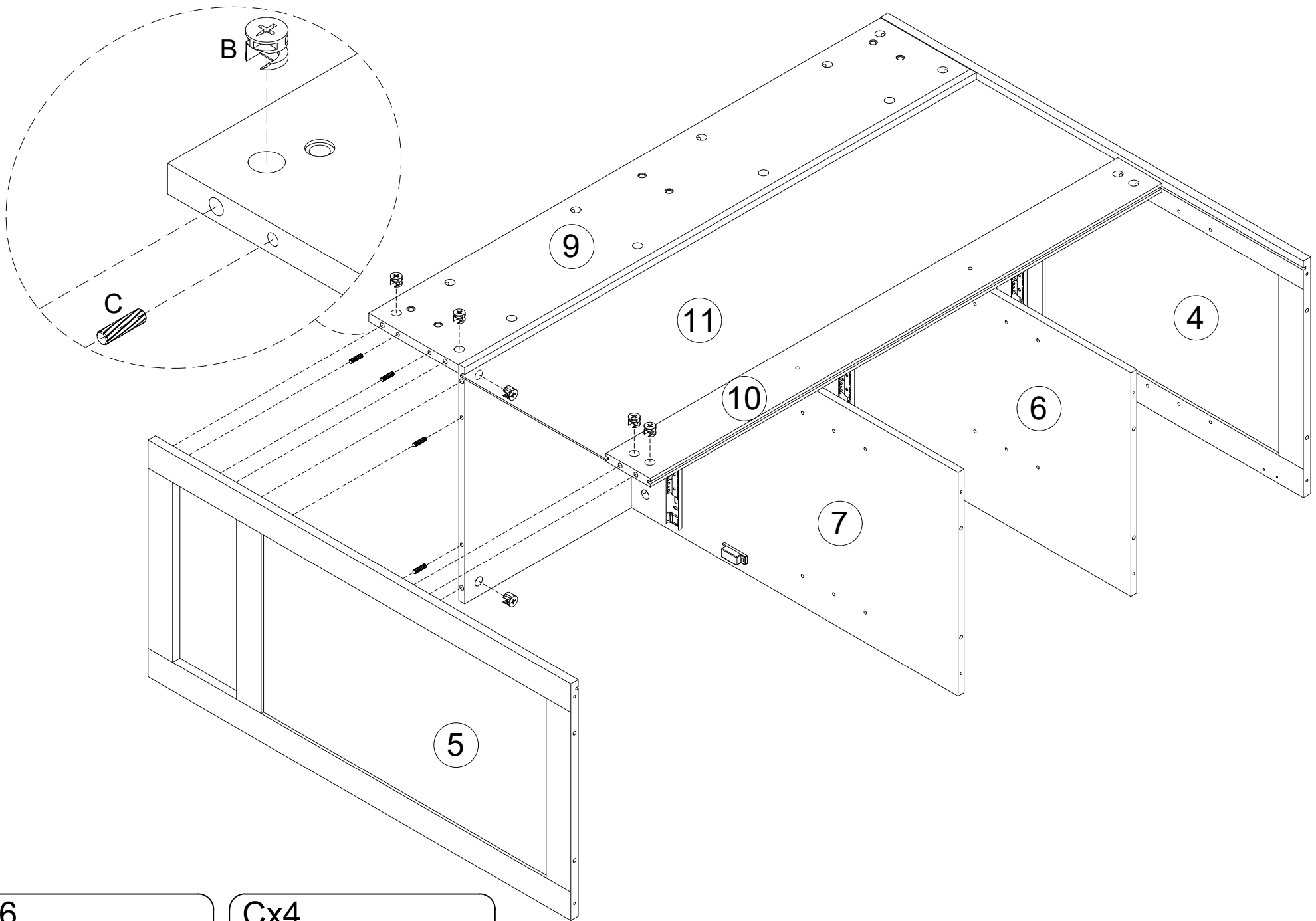

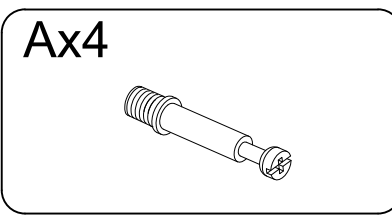
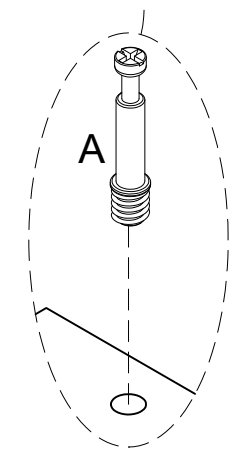
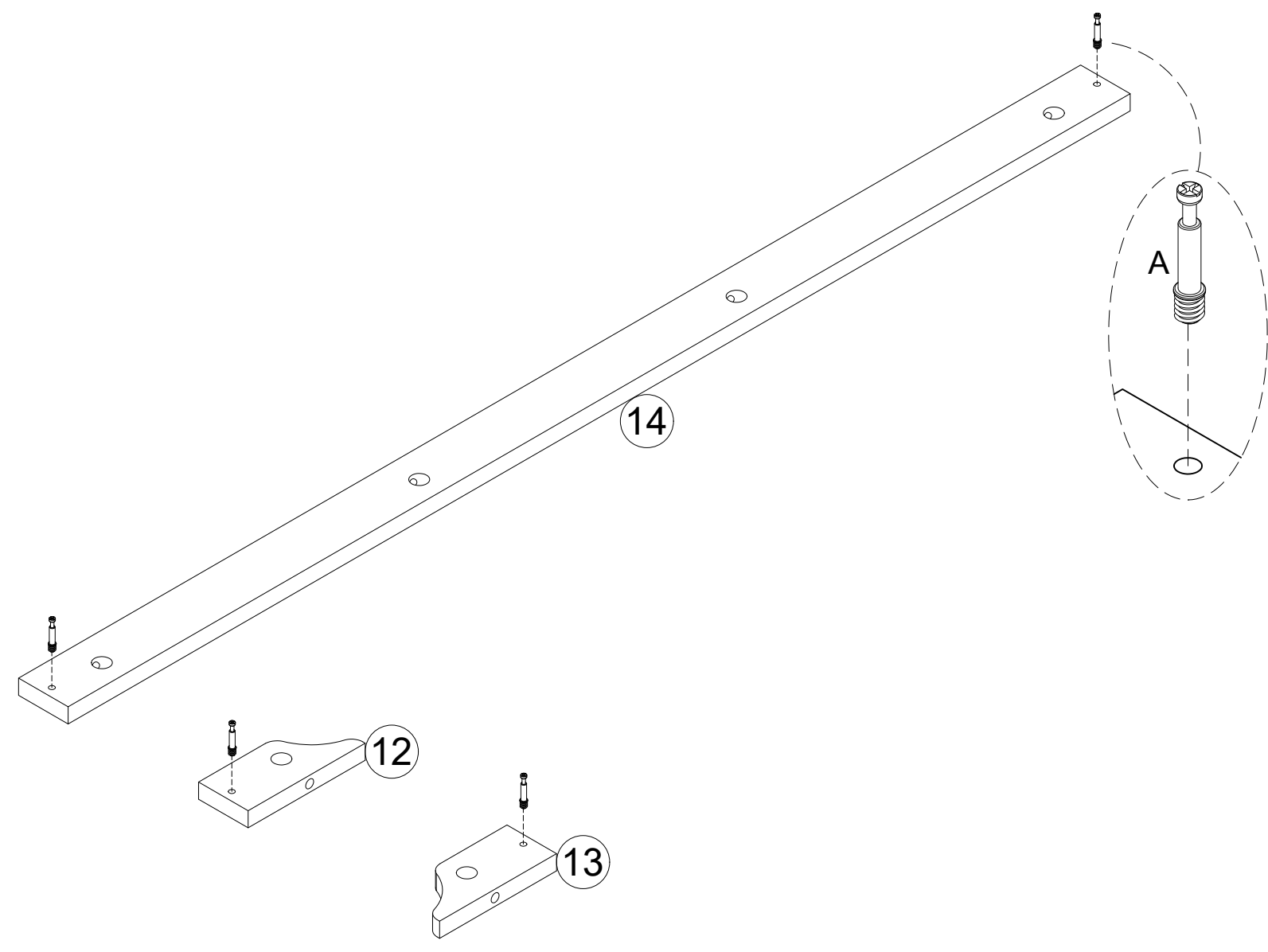
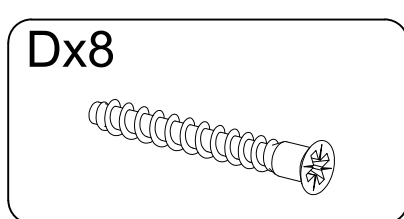
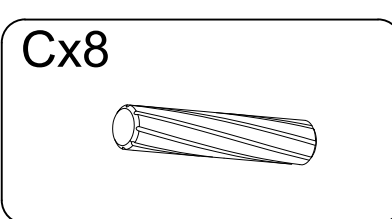
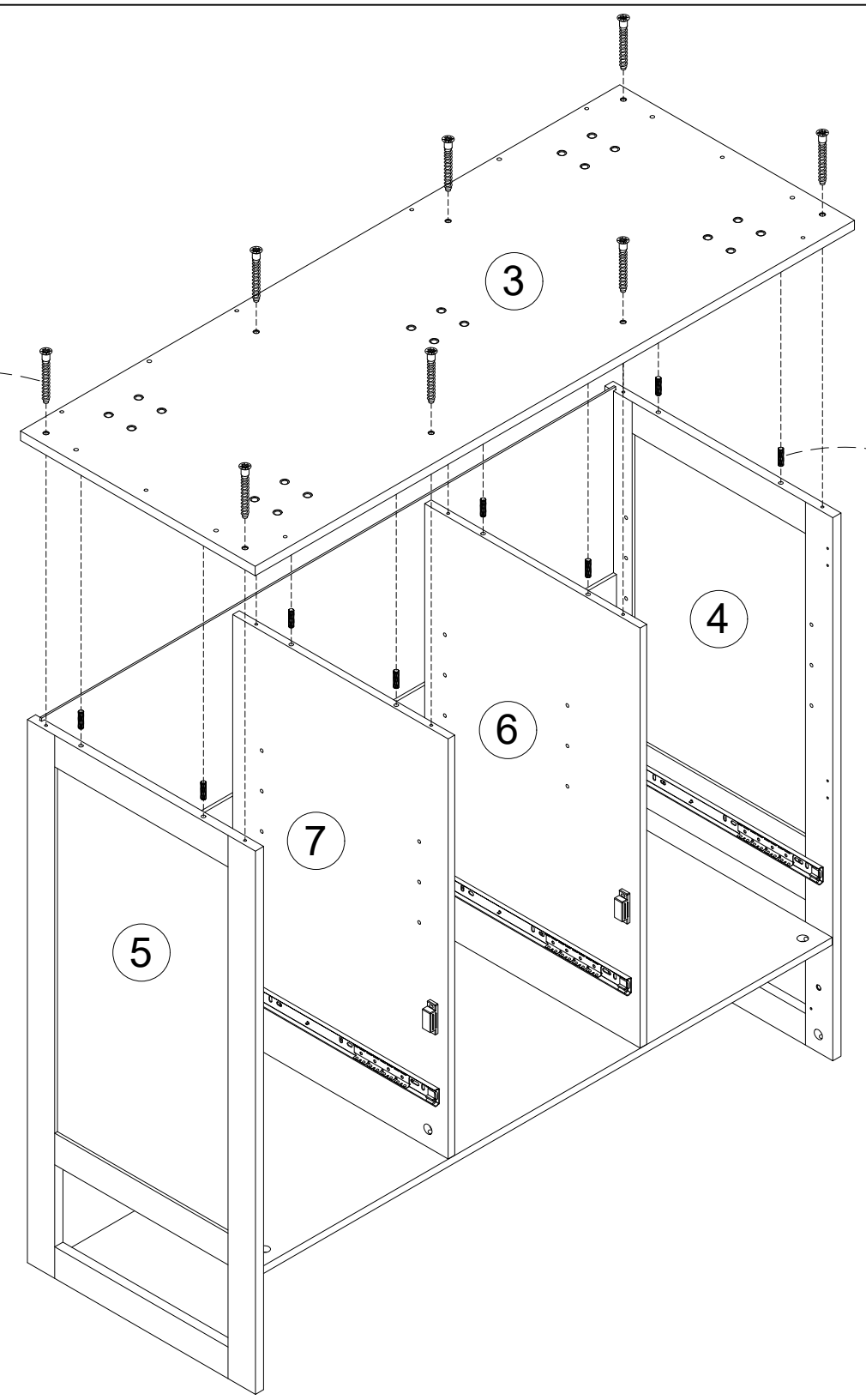
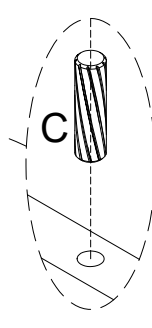
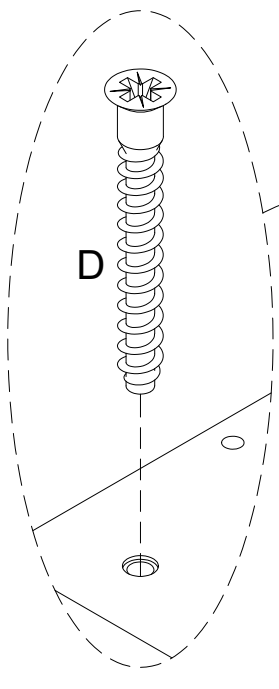

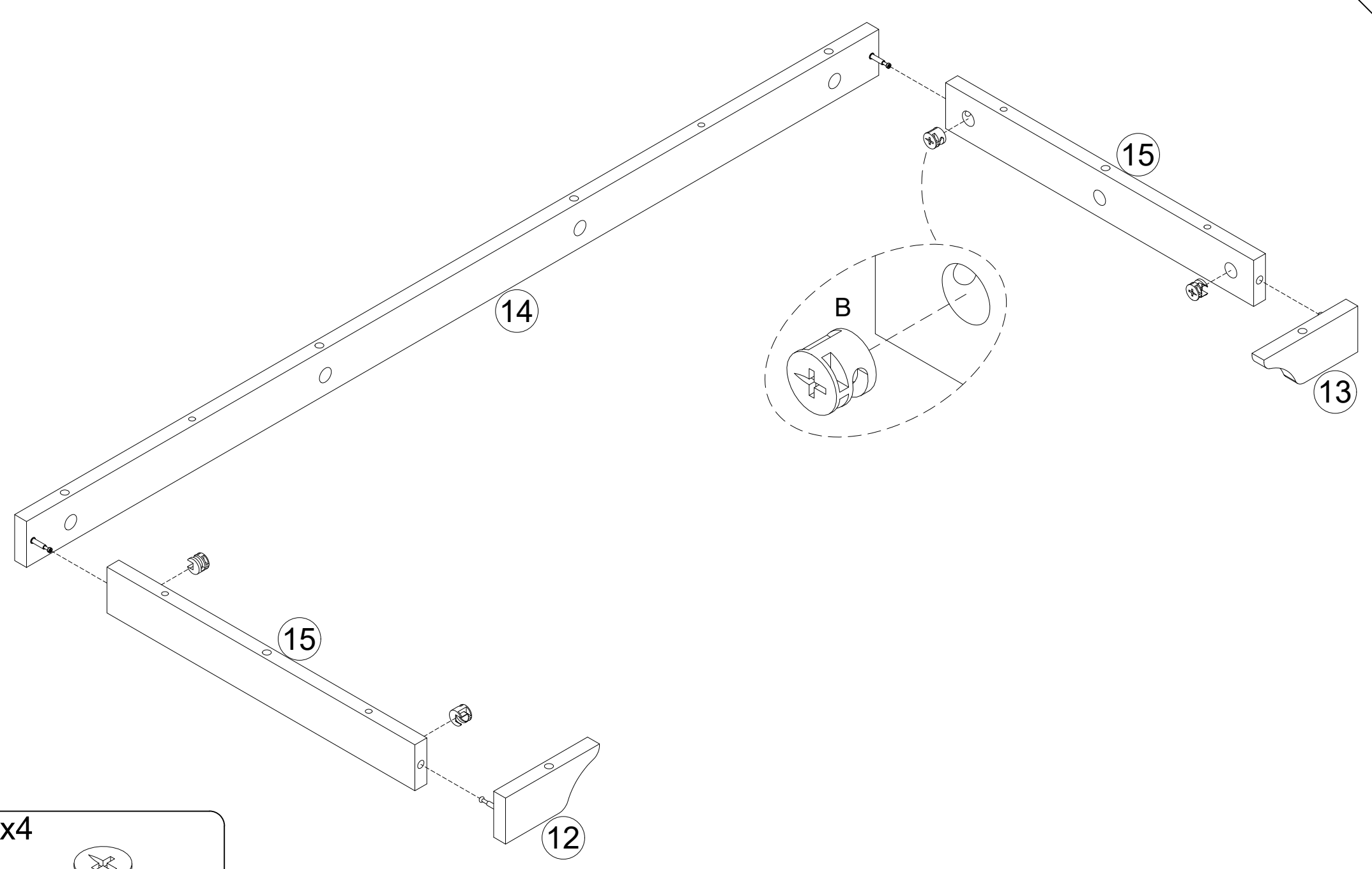

Bx4

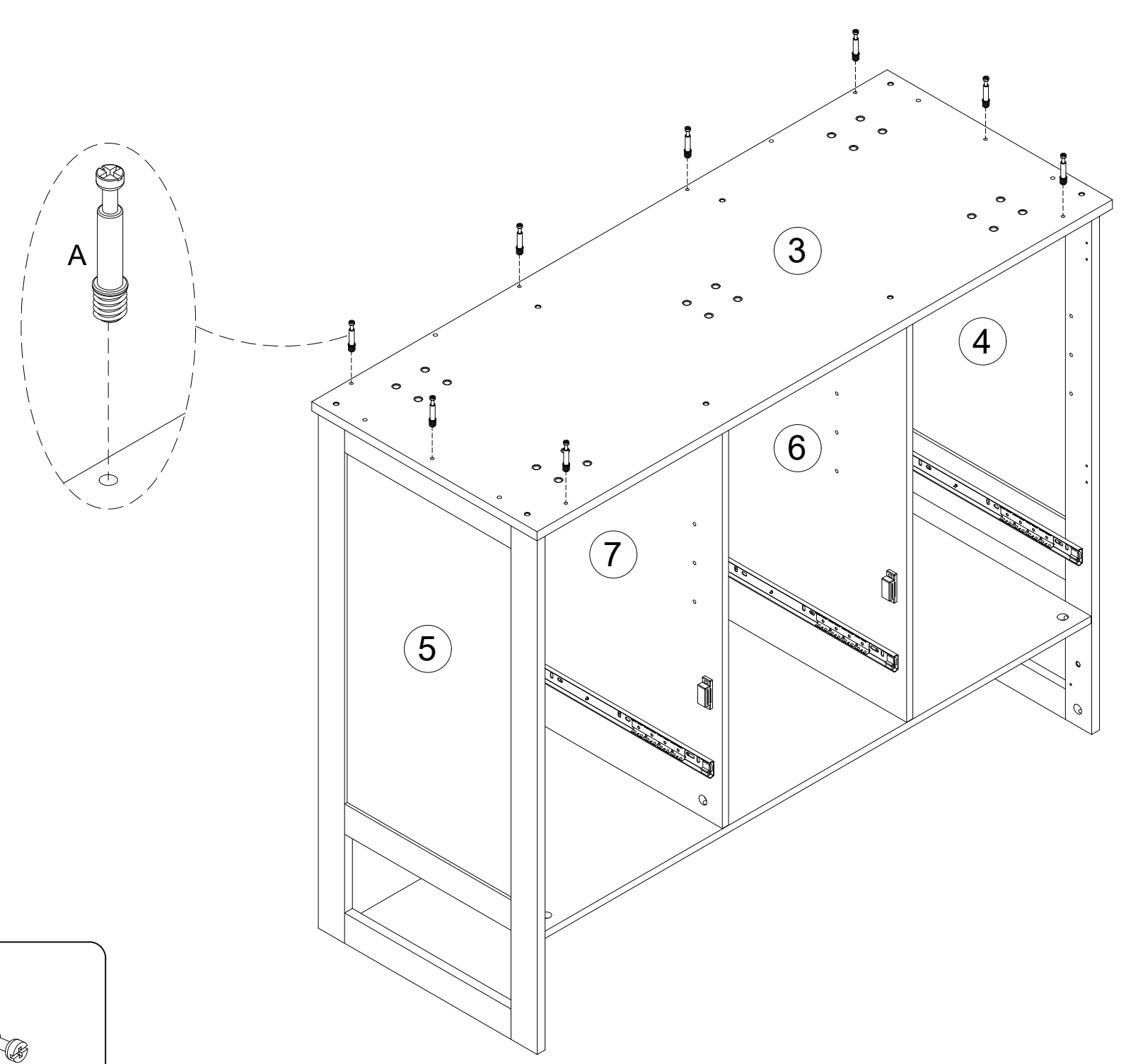

Ax8

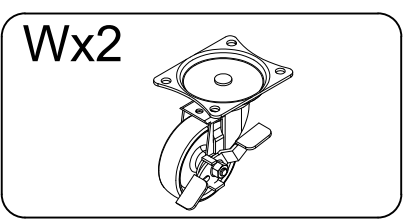
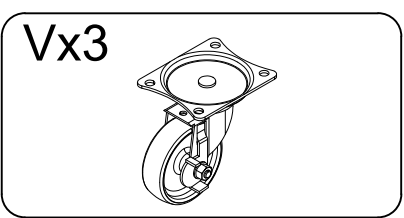
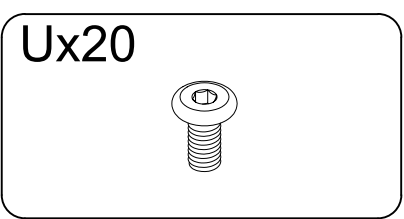
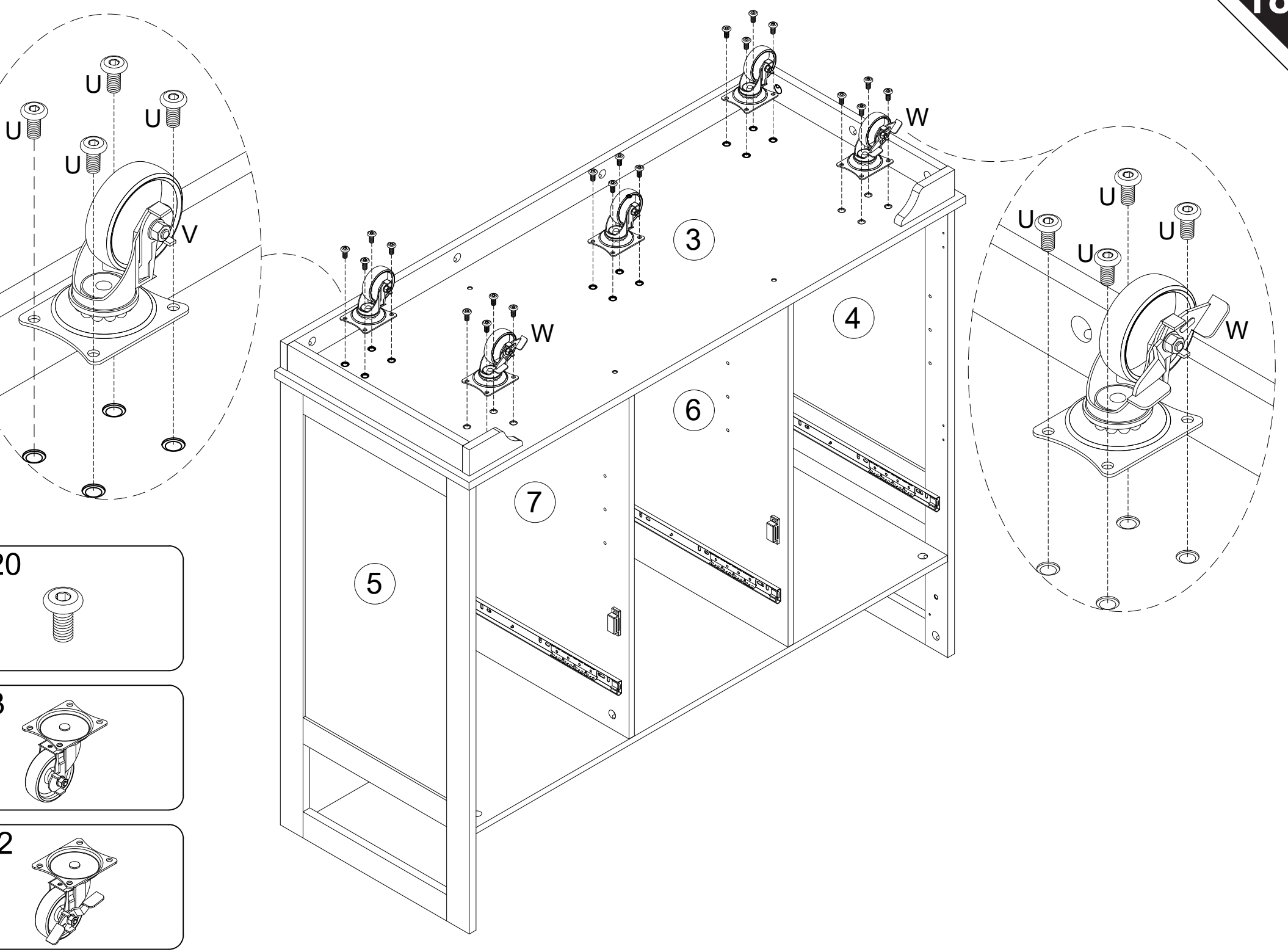
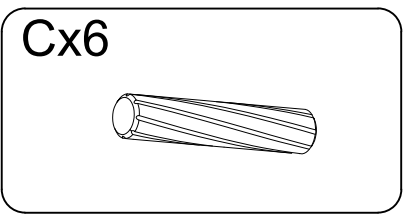
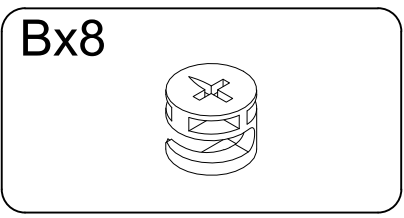
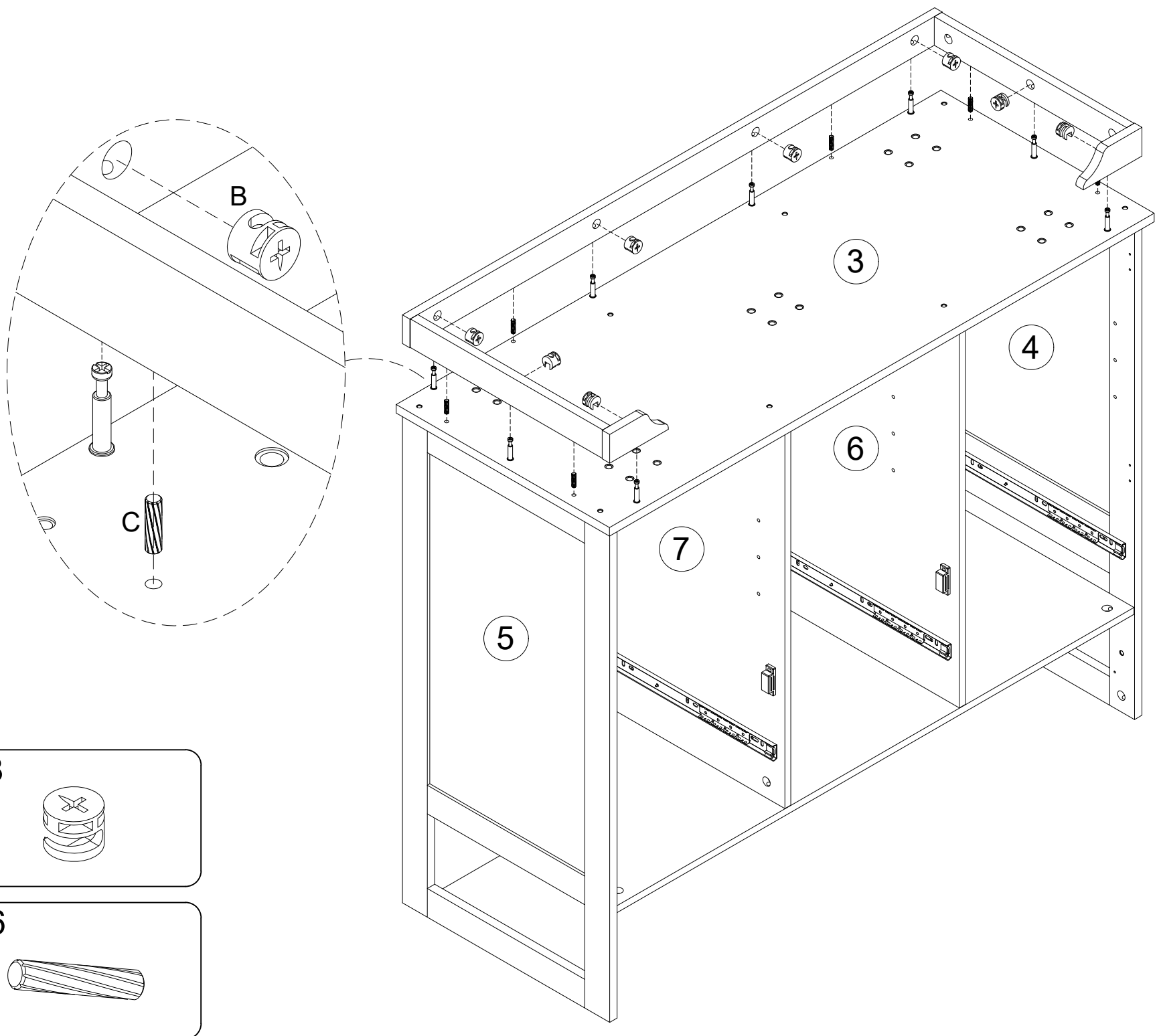

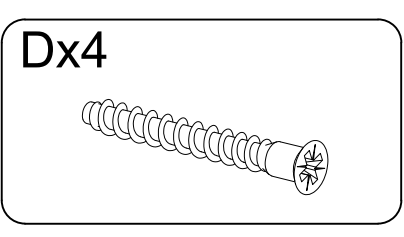
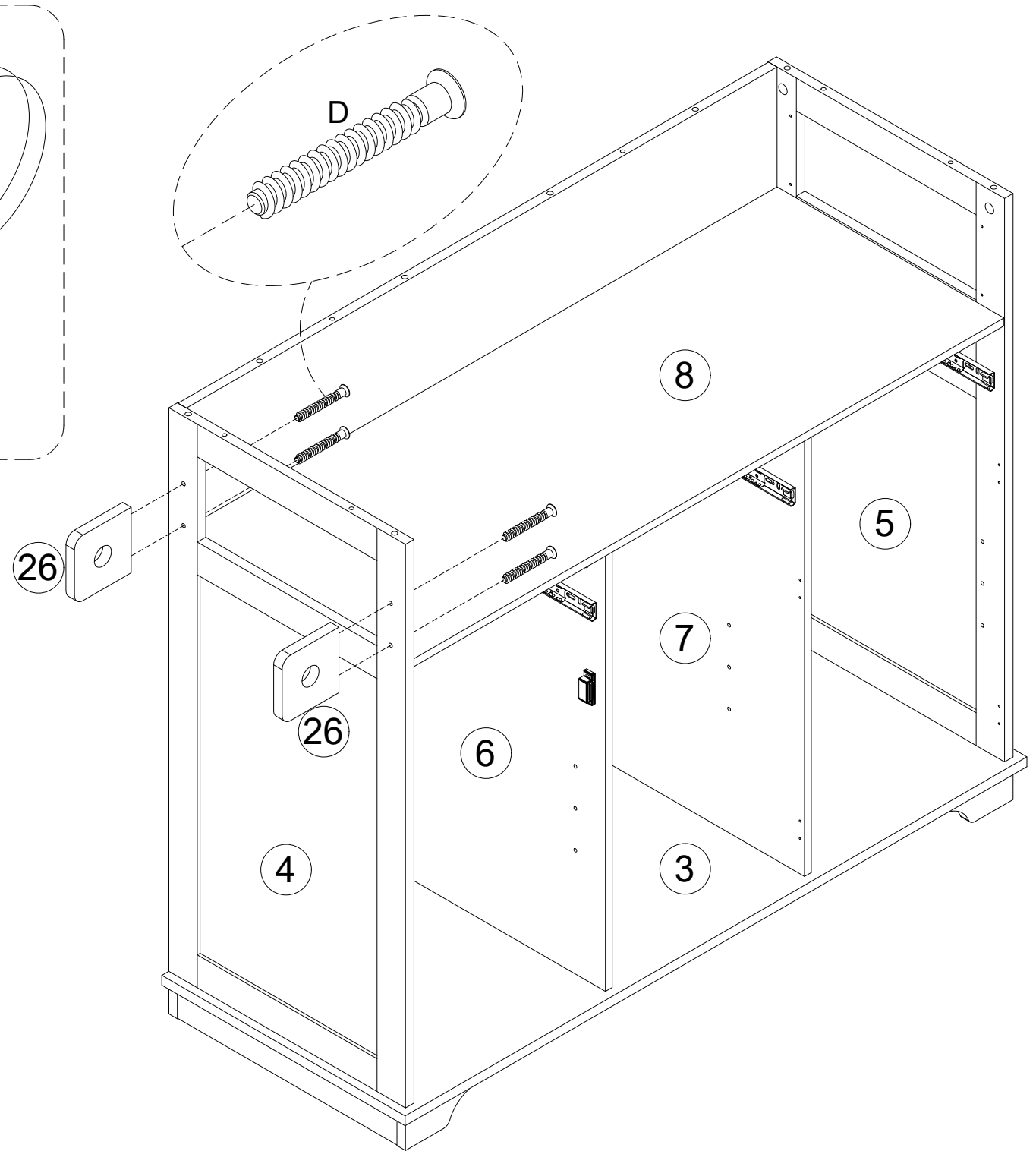
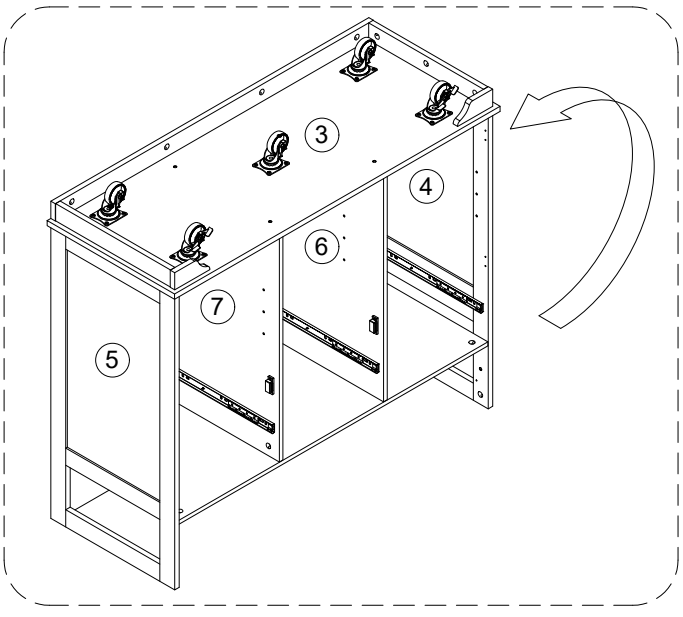

Pay attention to the obverse and the reverse of the X-shaped iron frame

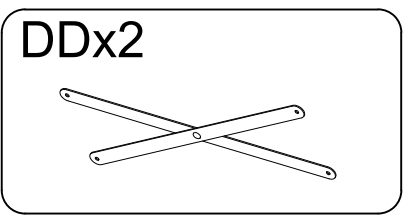
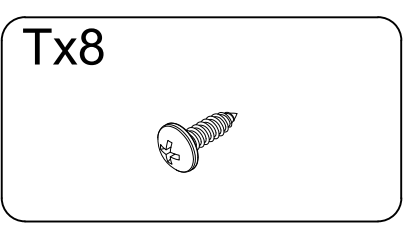
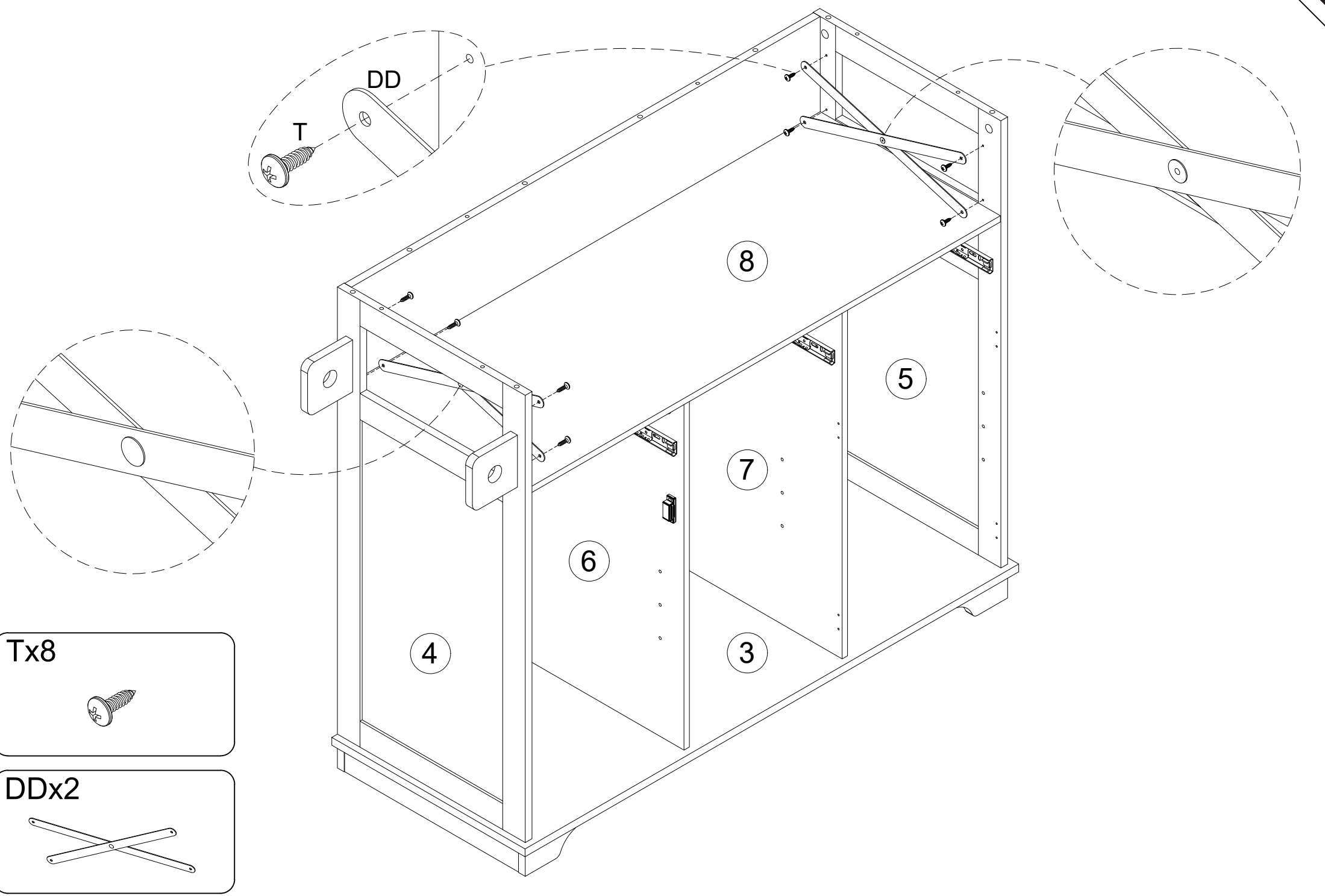

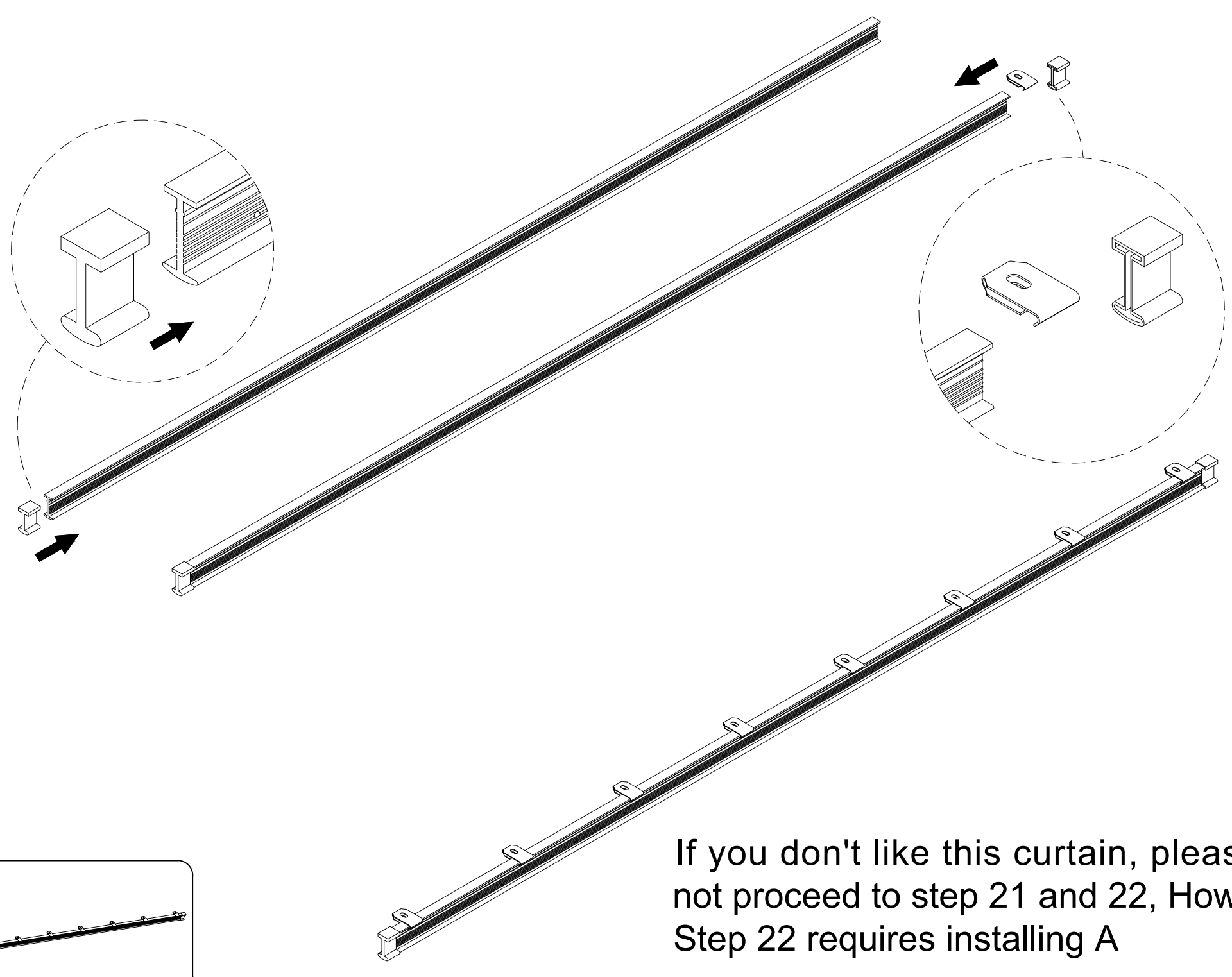

If you don't like this curtain, please do not proceed to step 21 and 22, However, Step 22 requires installing A

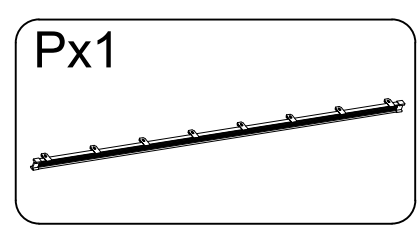

The clasp can be moved to the correct hole position

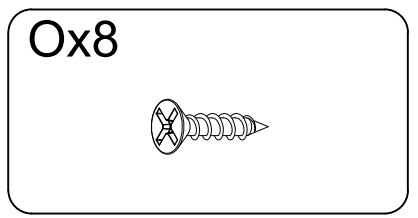
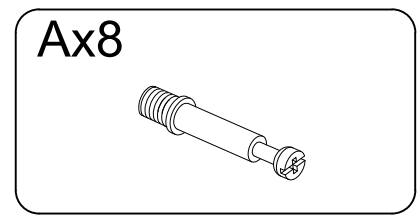
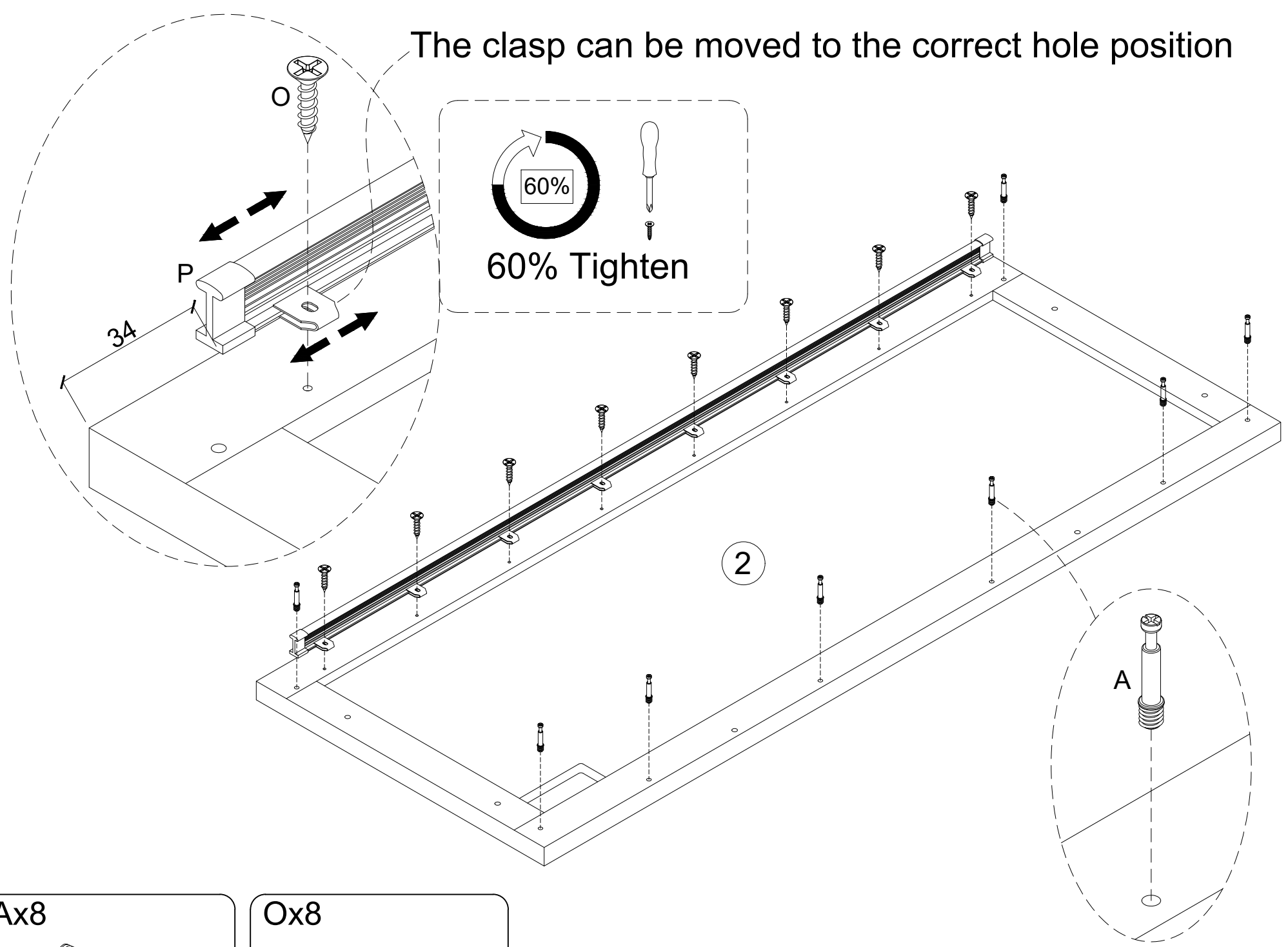

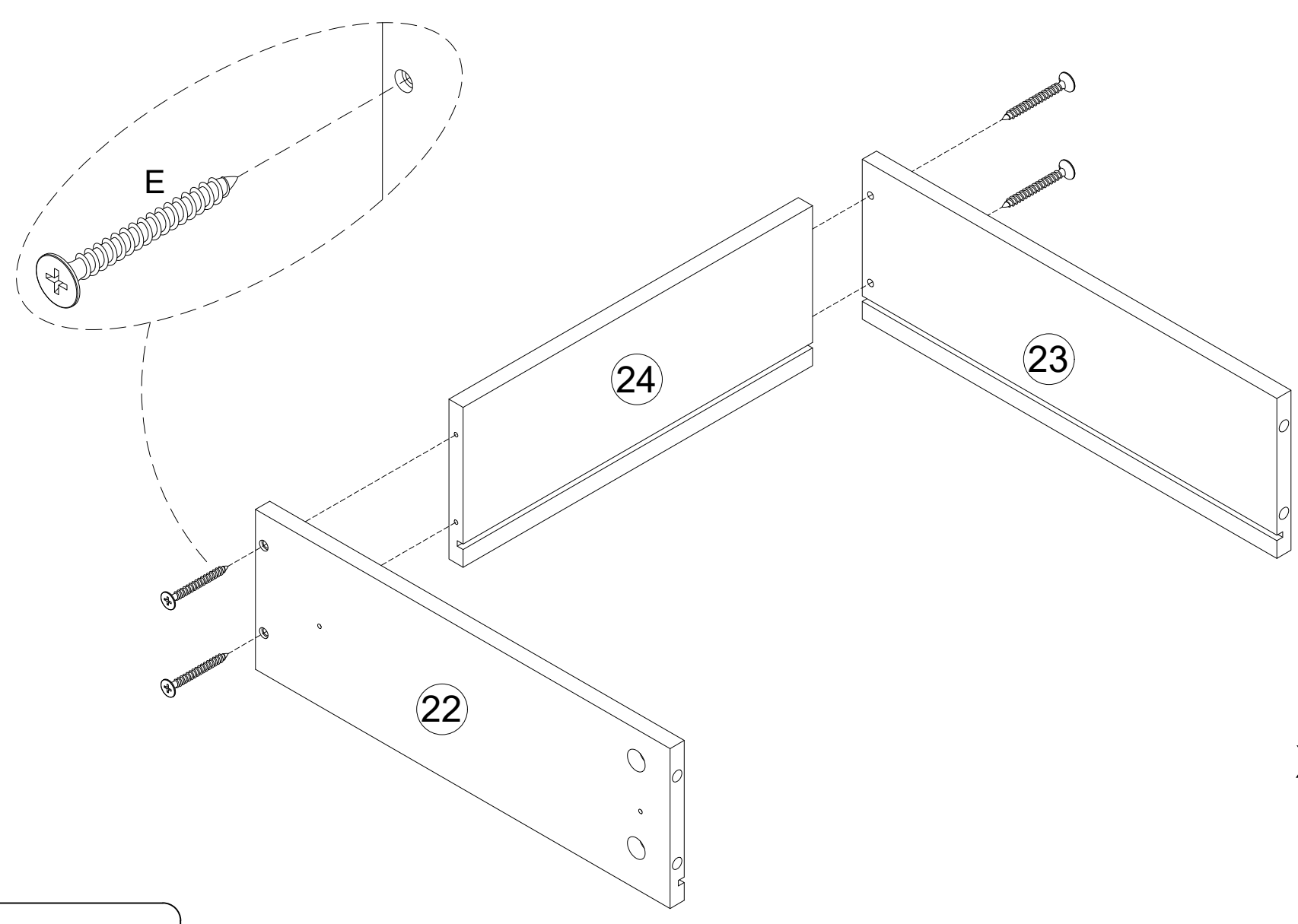
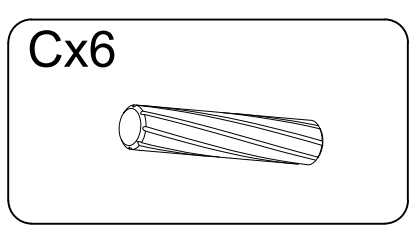
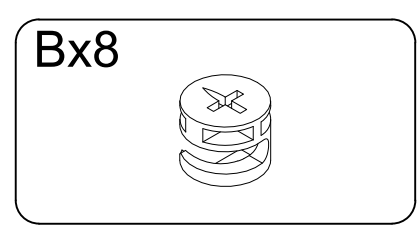
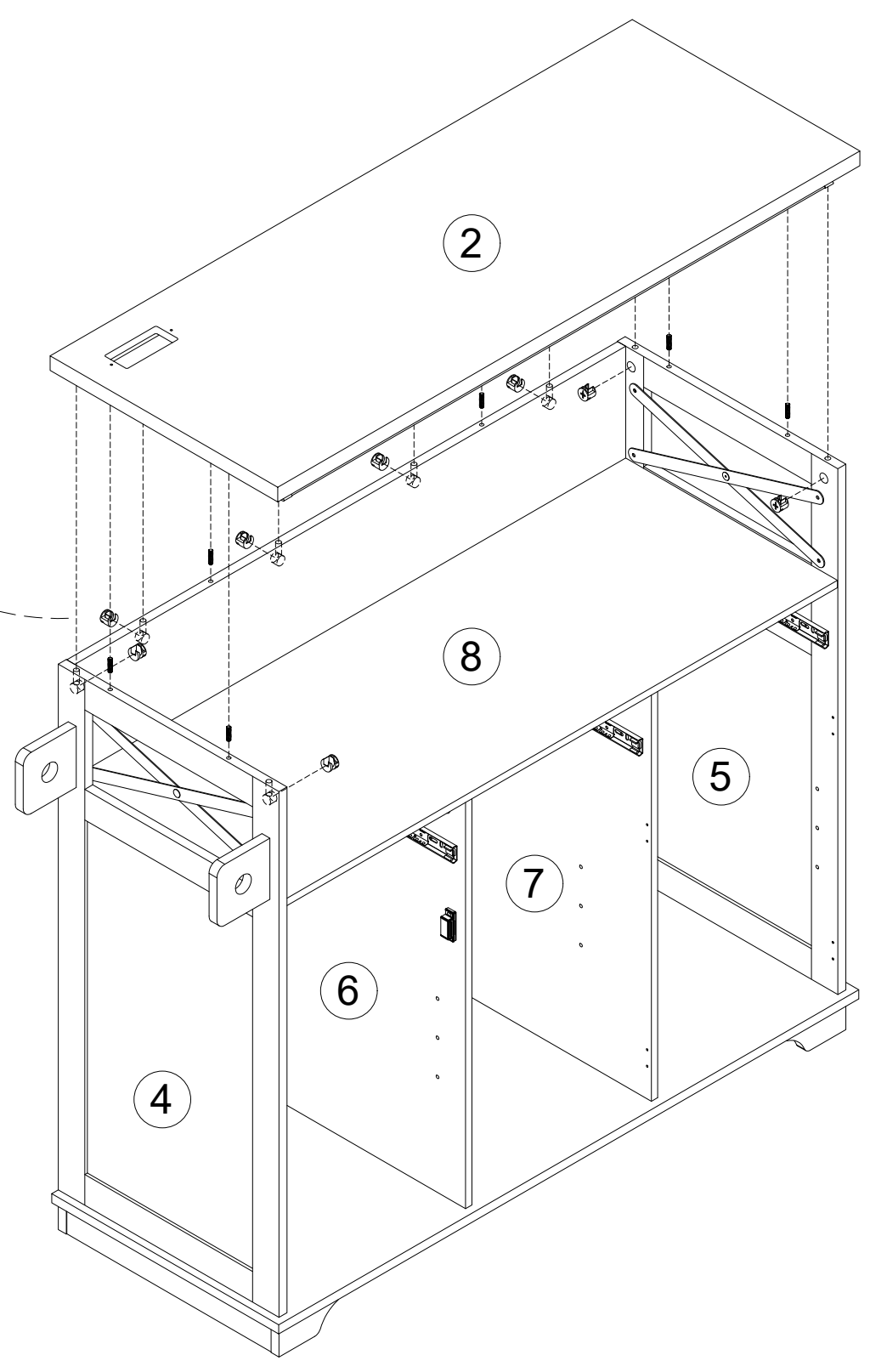
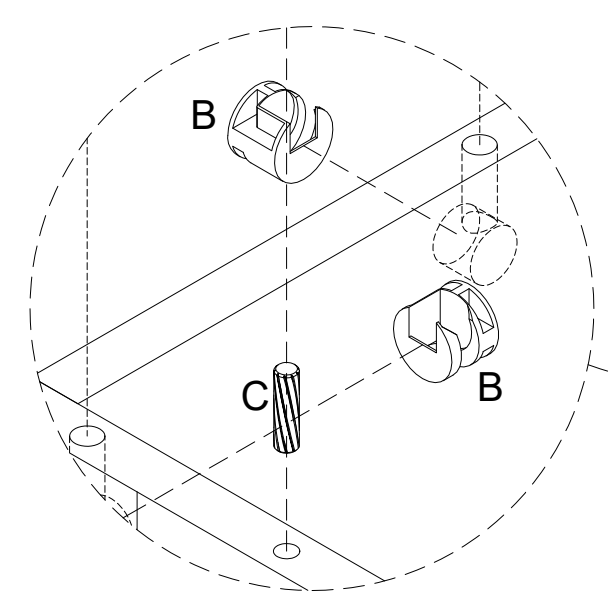

x3

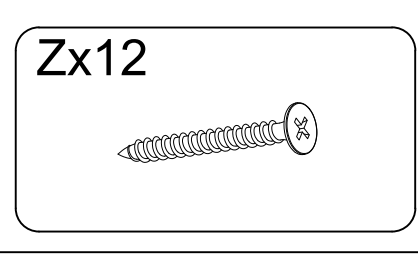

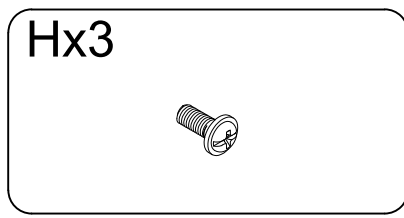
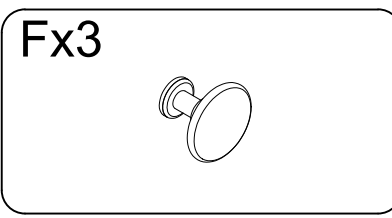
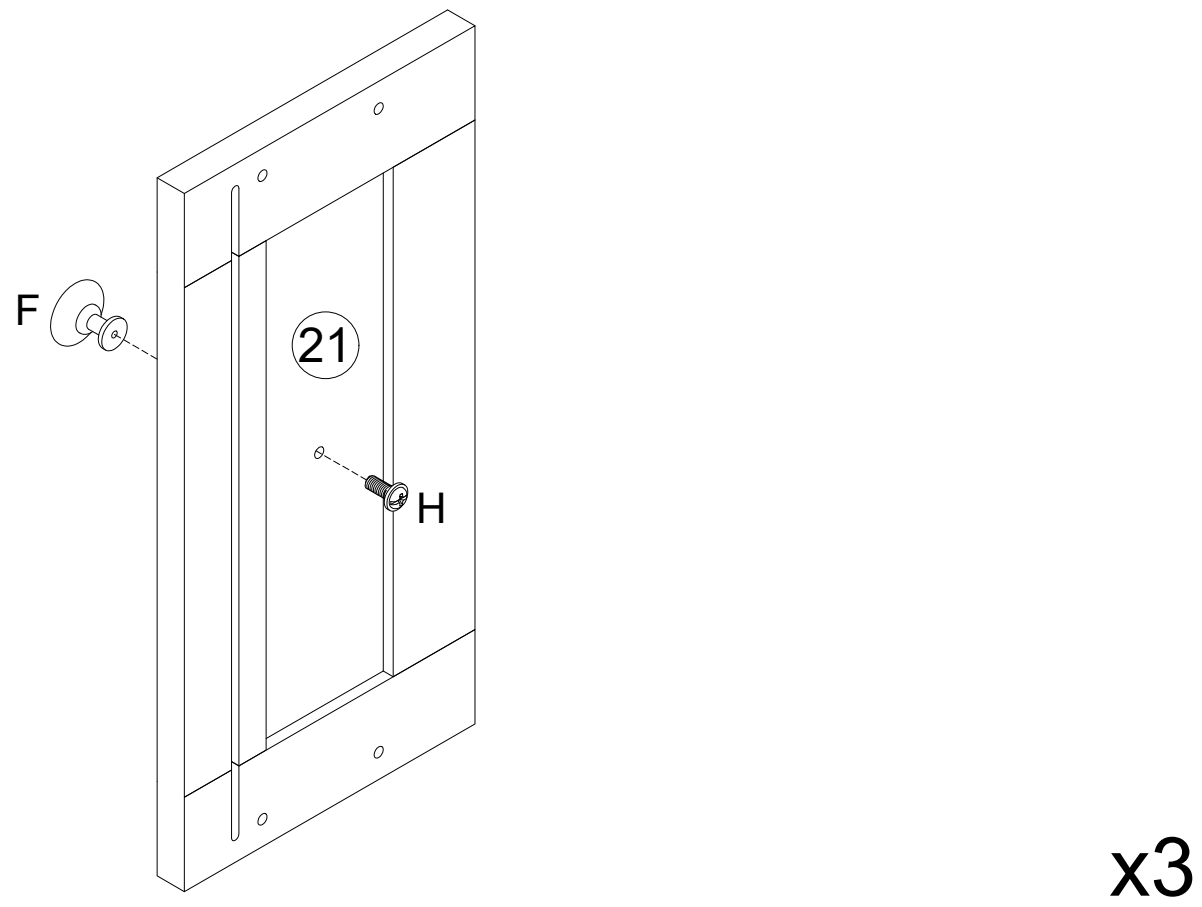
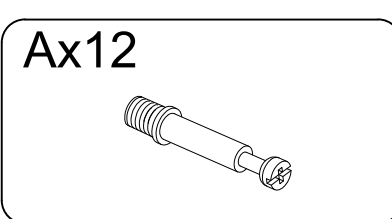
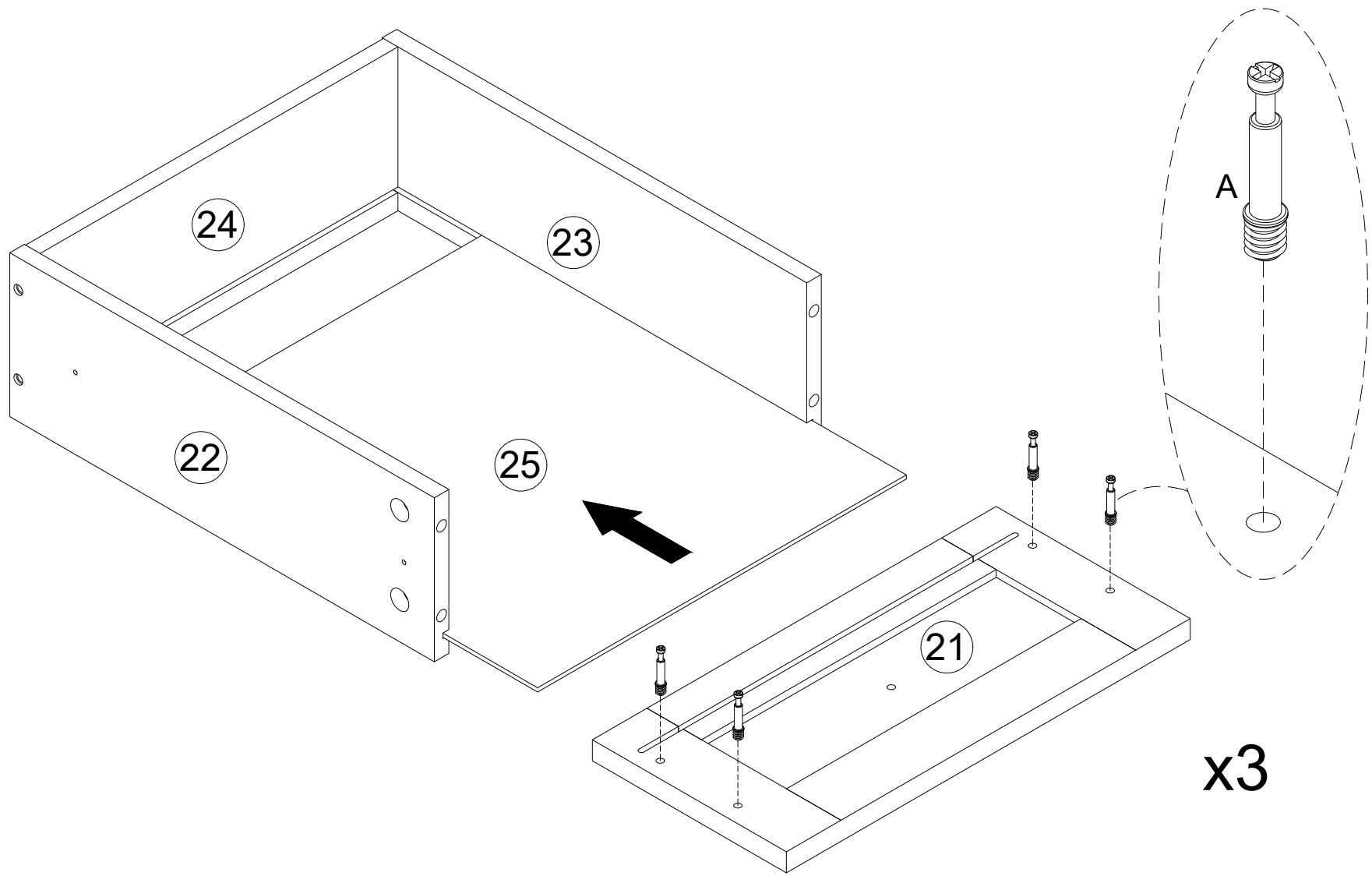

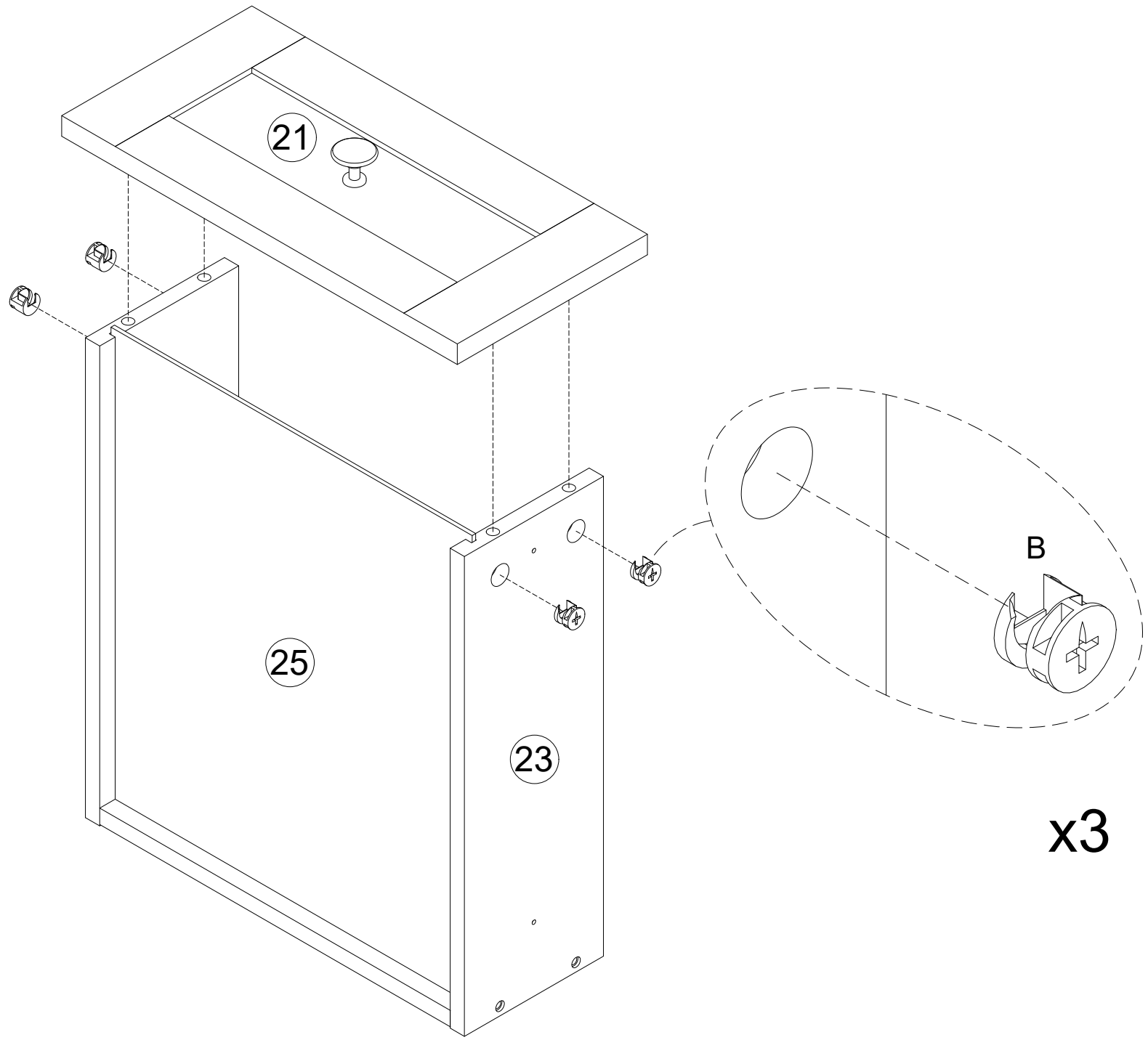

Bx12

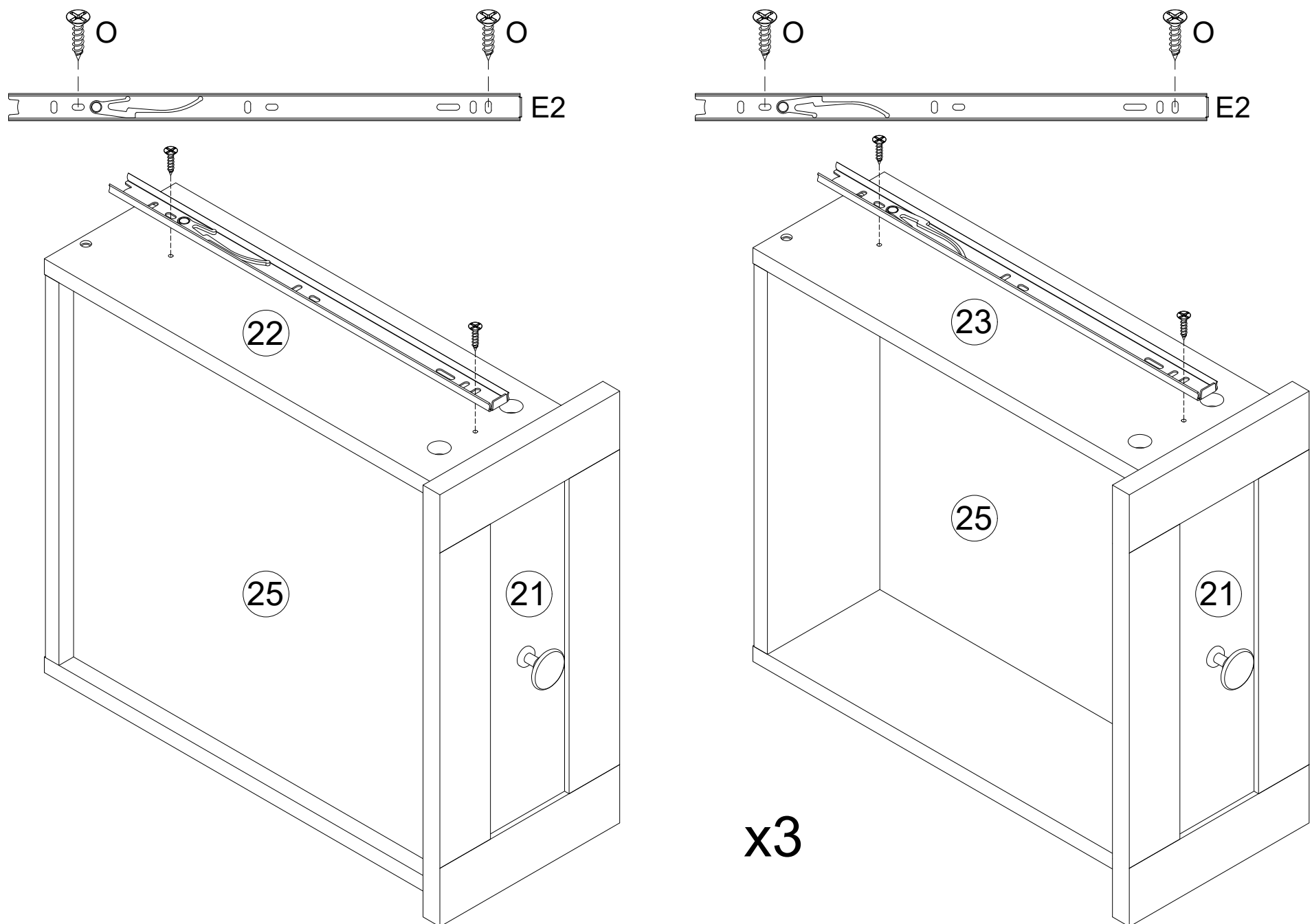
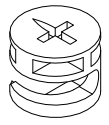

E2x6



Ox12

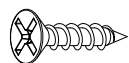

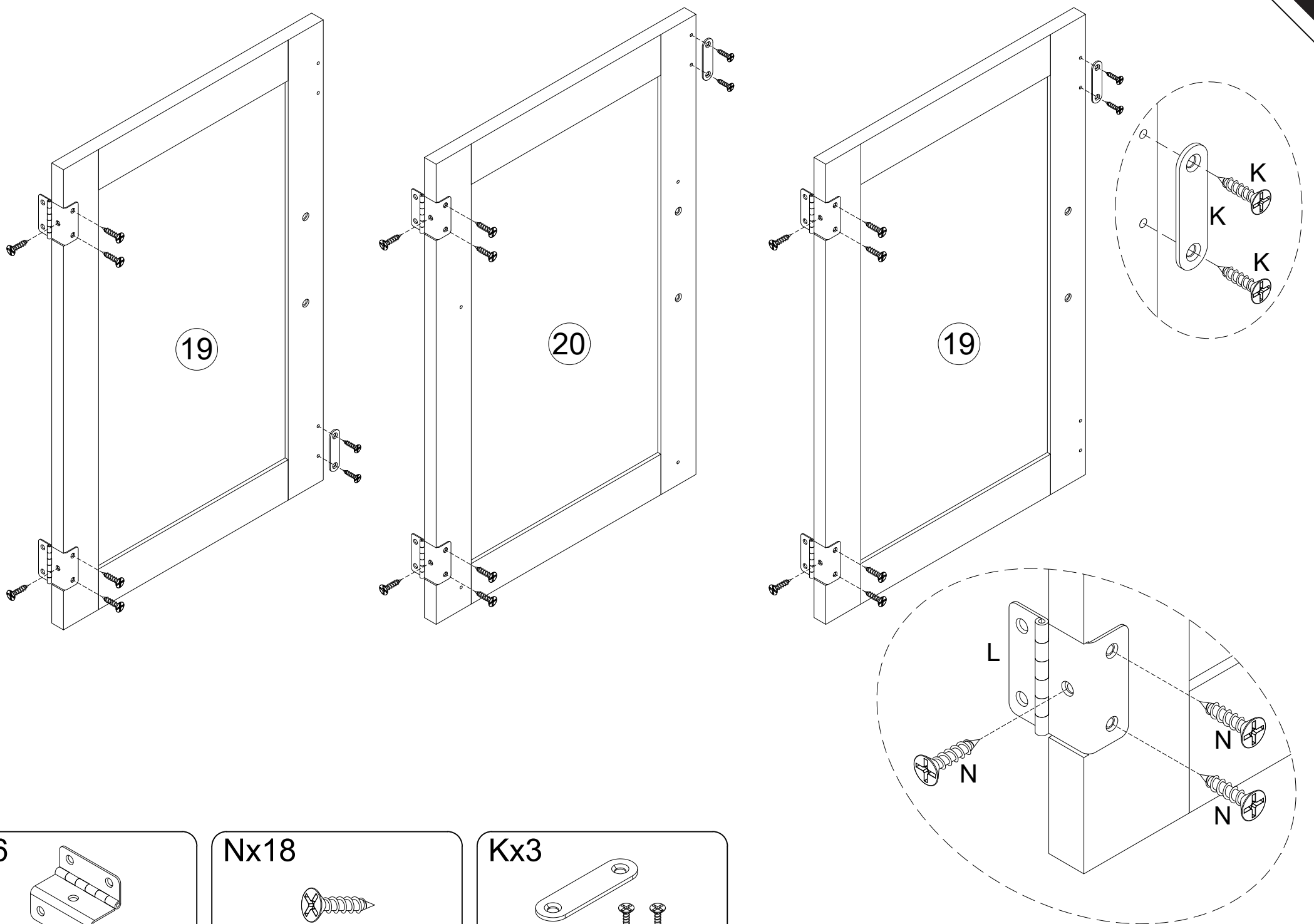
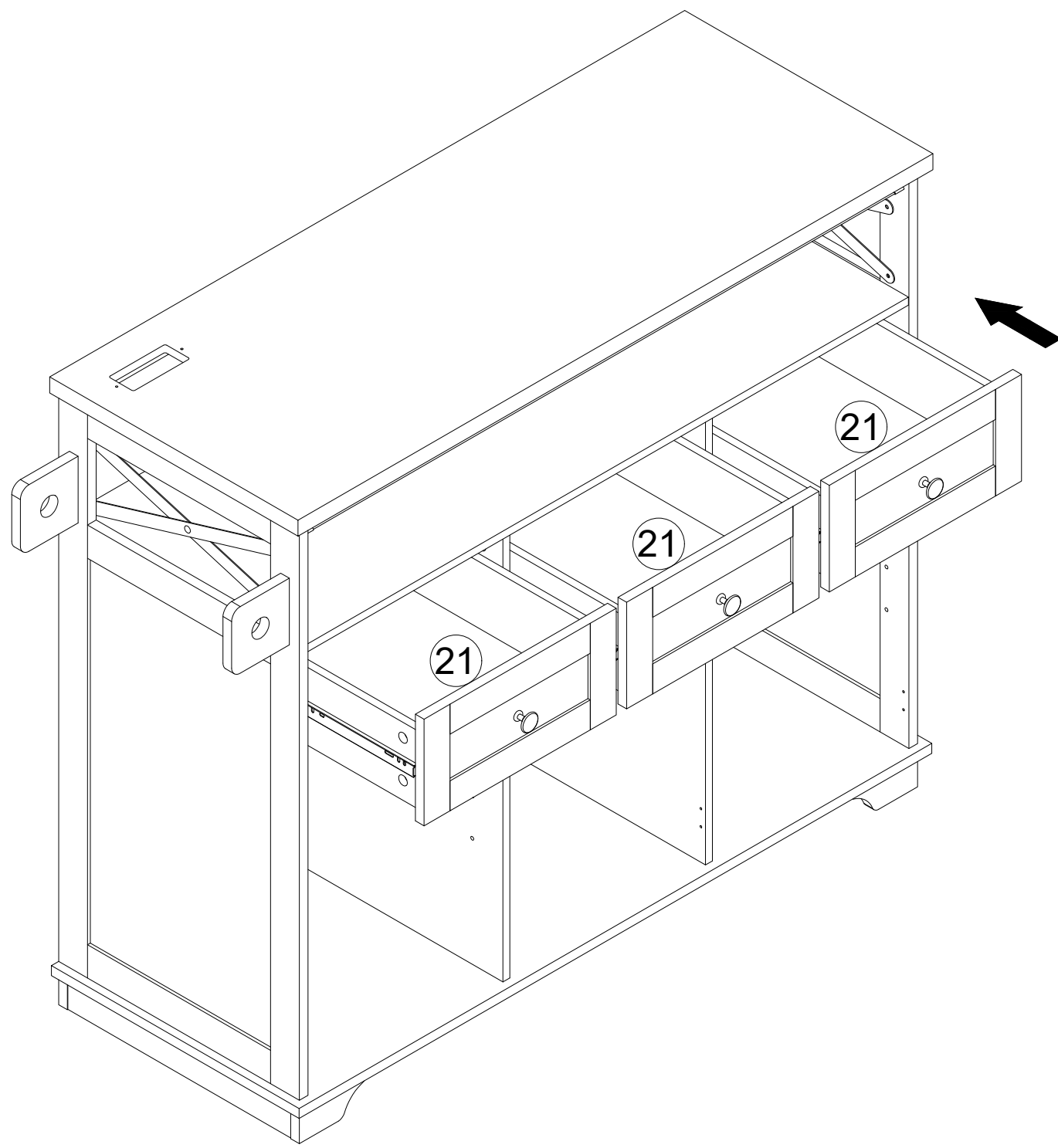

Lx6

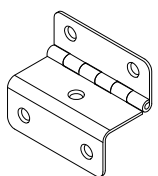

Nx18

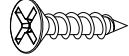

Kx3

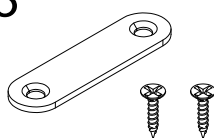

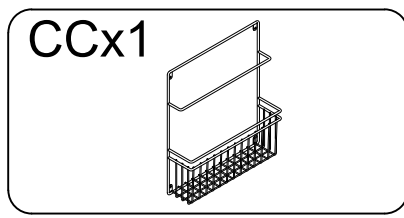
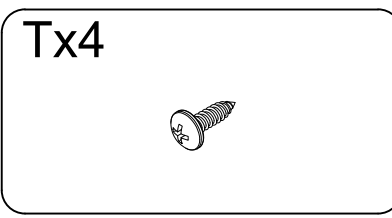
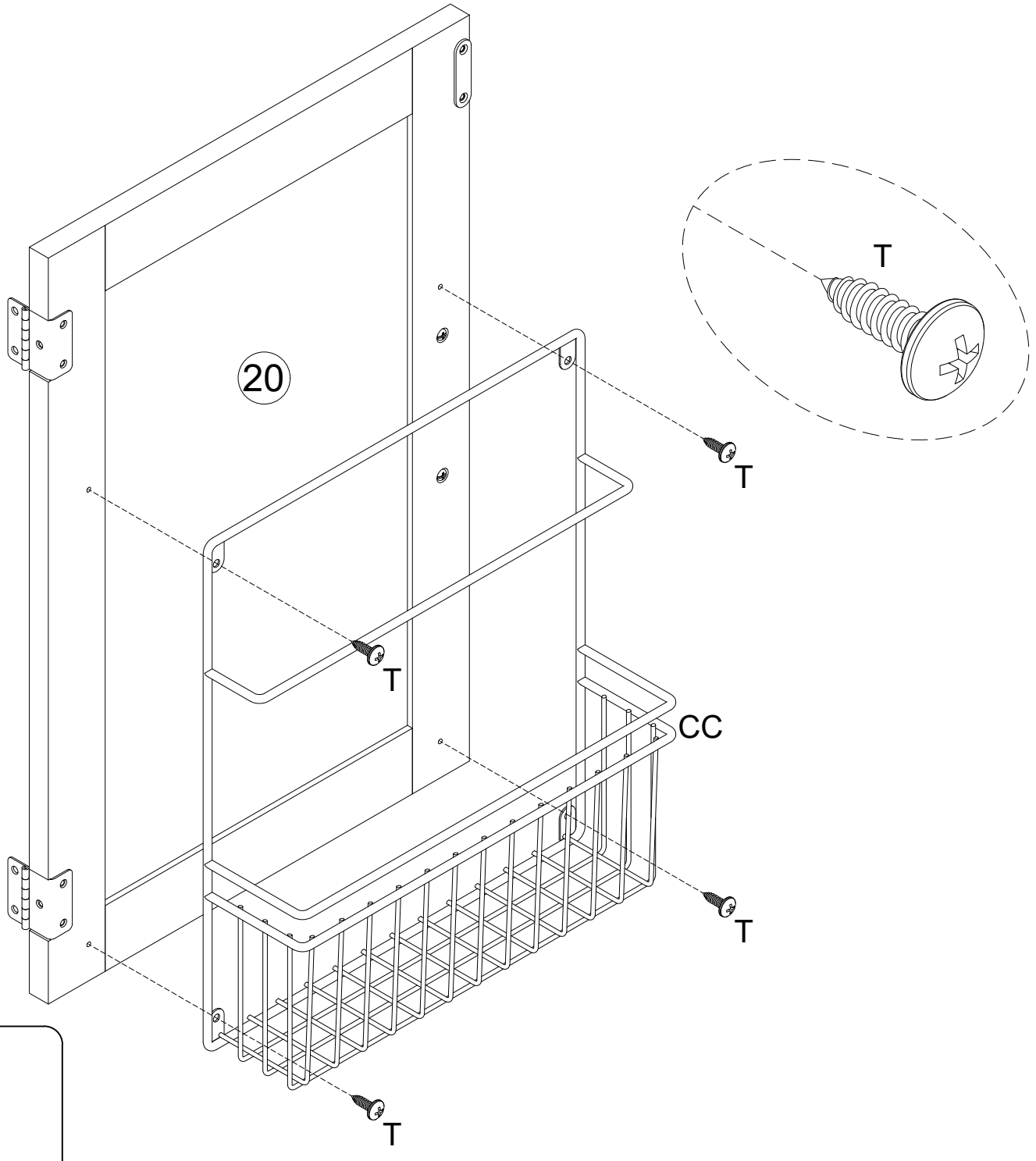
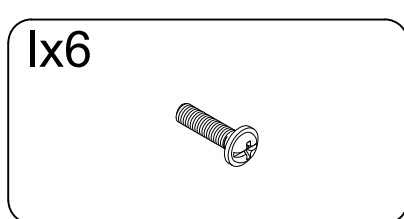
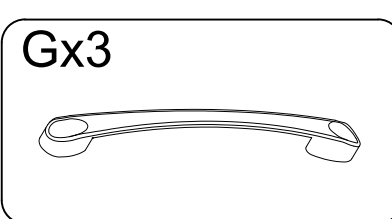
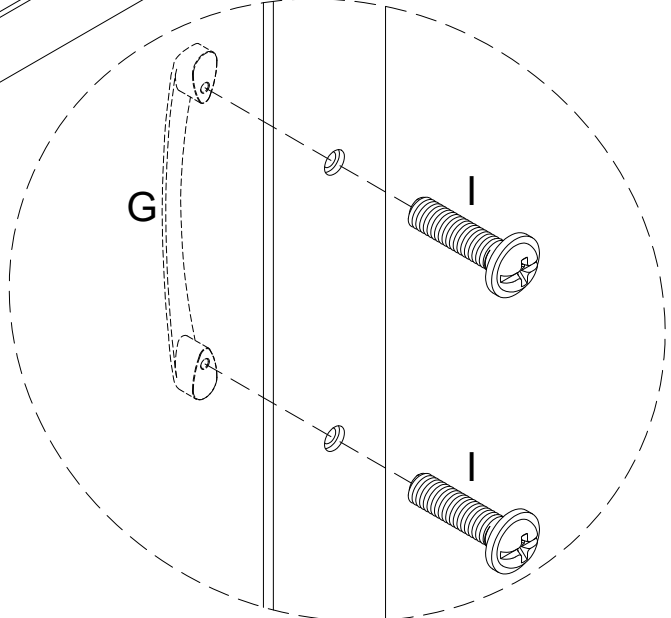
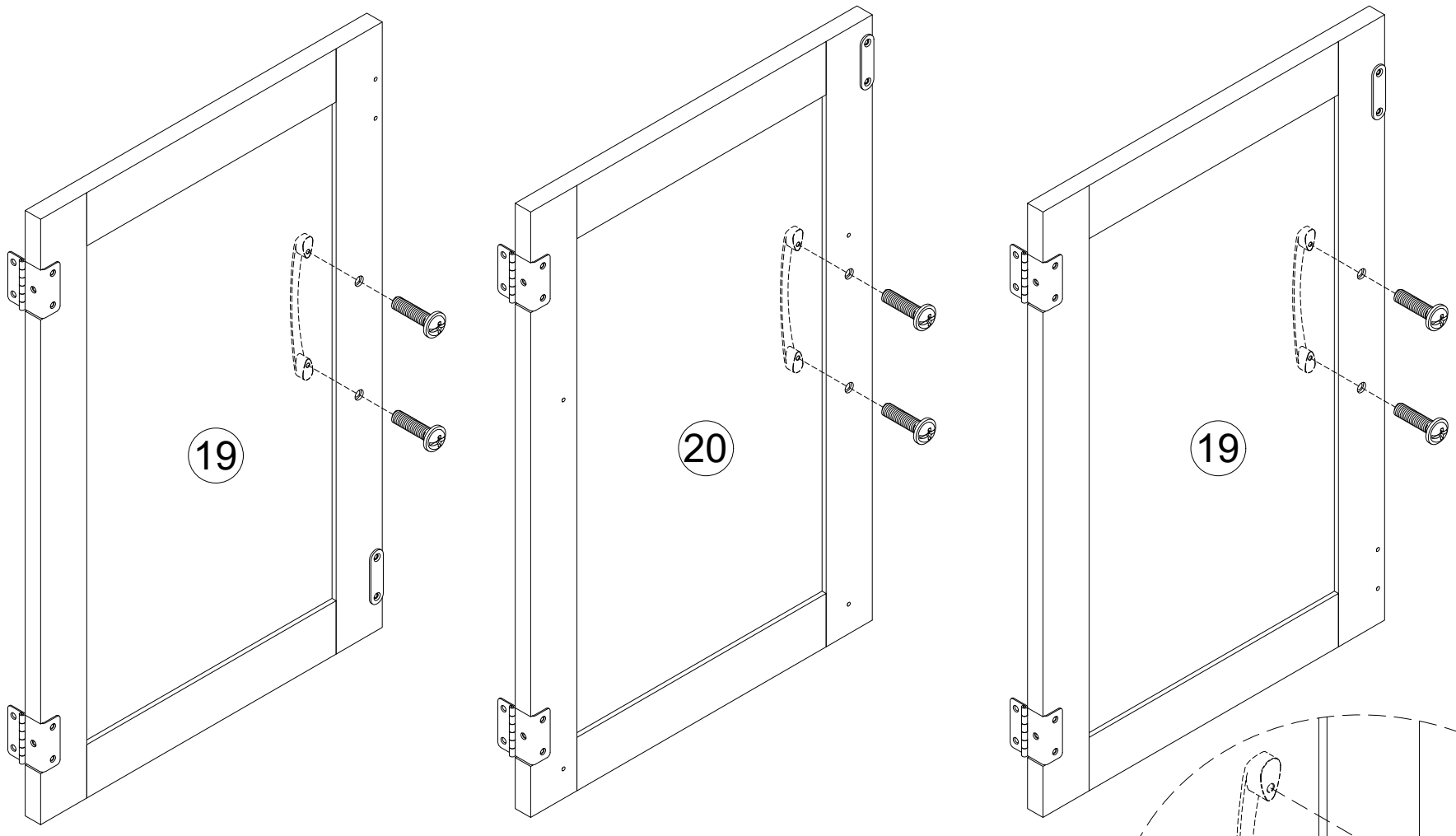

Install the door first, then adjust the suction position of the door, so that the door is level with the front, and finally lock the screw of the door suction **J** to 99%

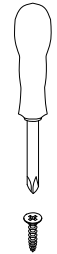
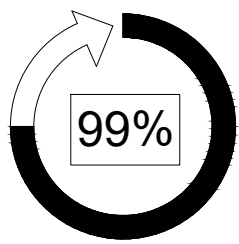

99% festziehen

Nx12

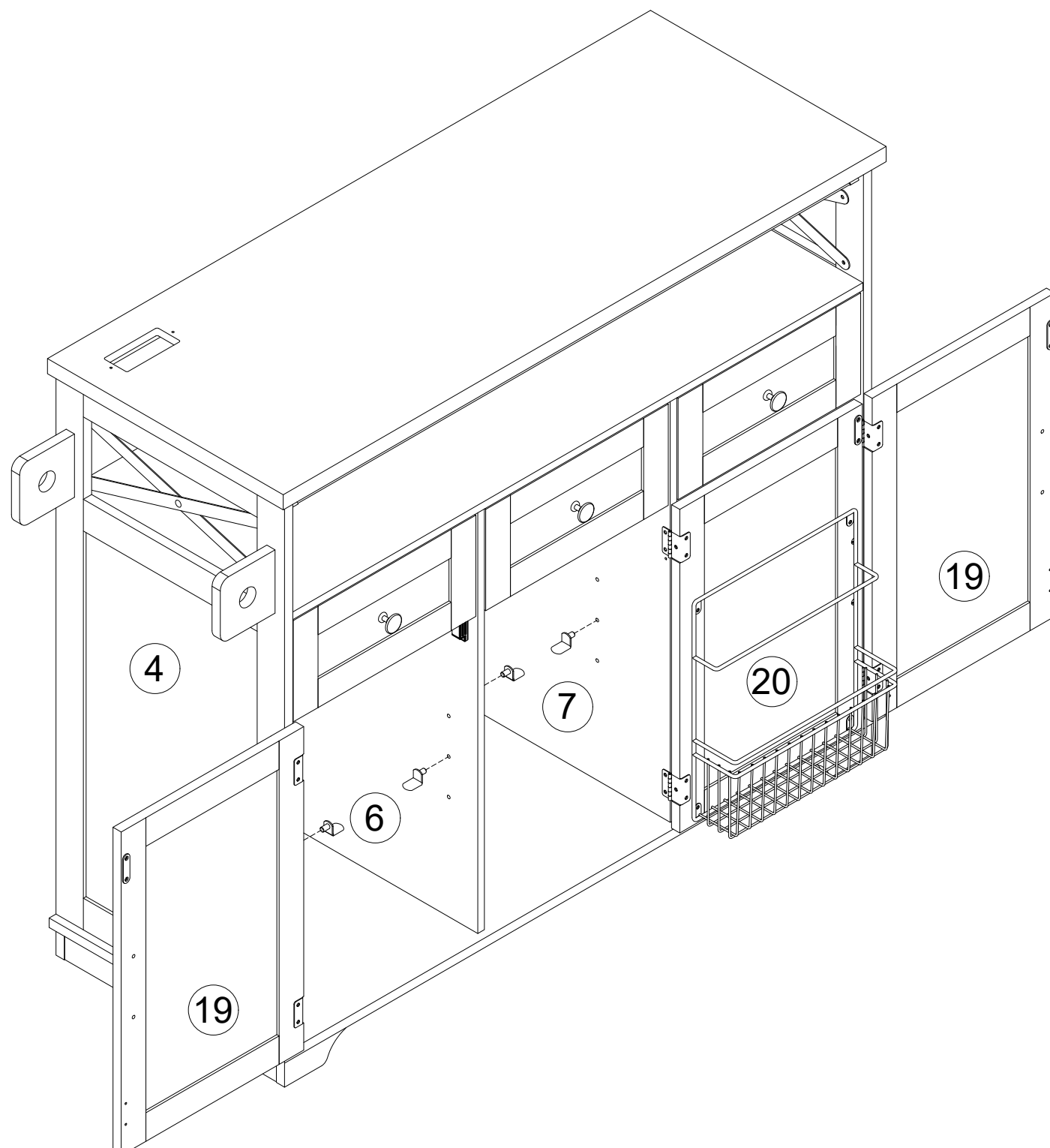
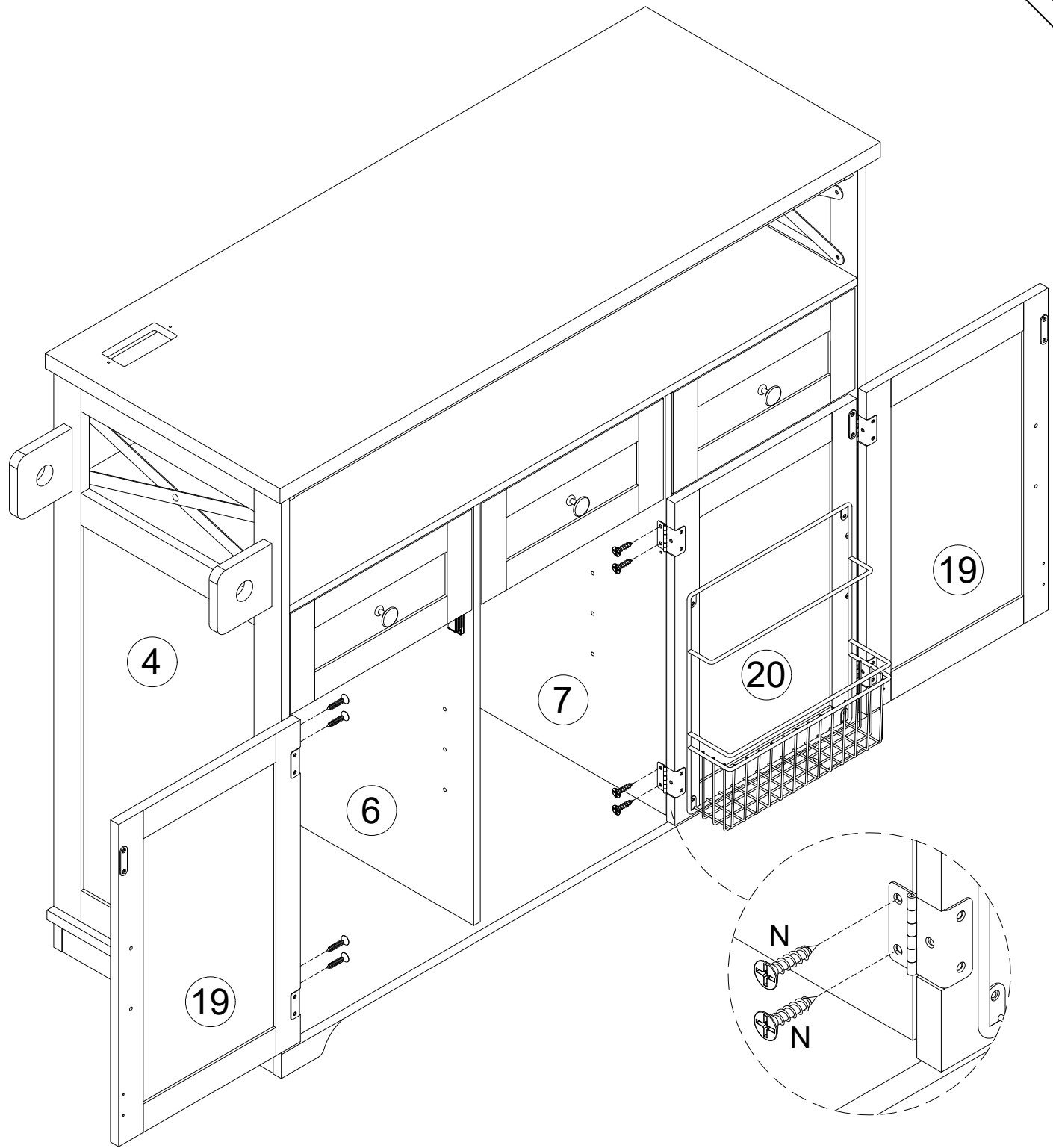
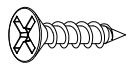

Mx8

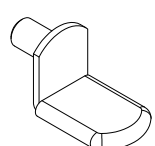

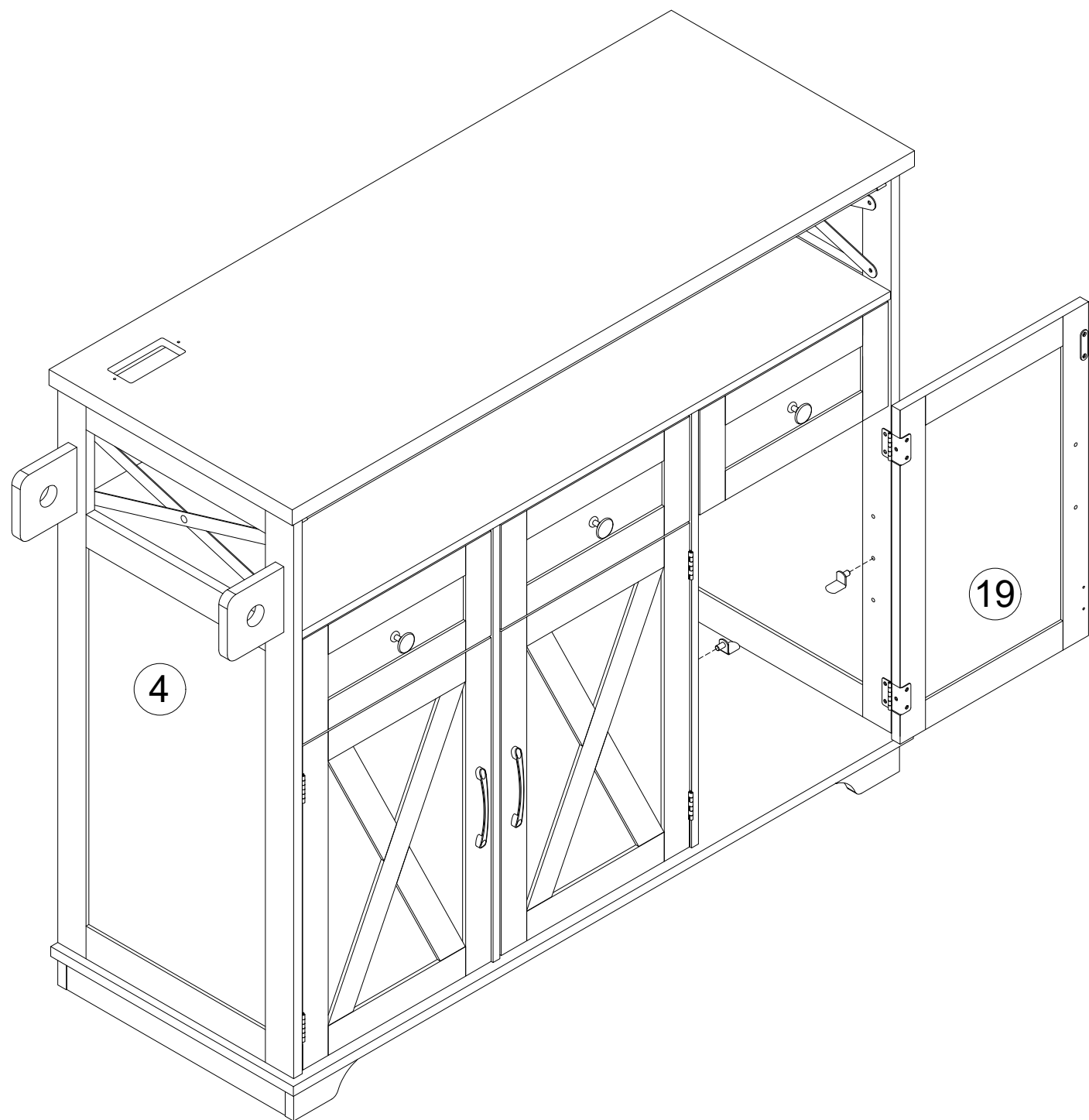
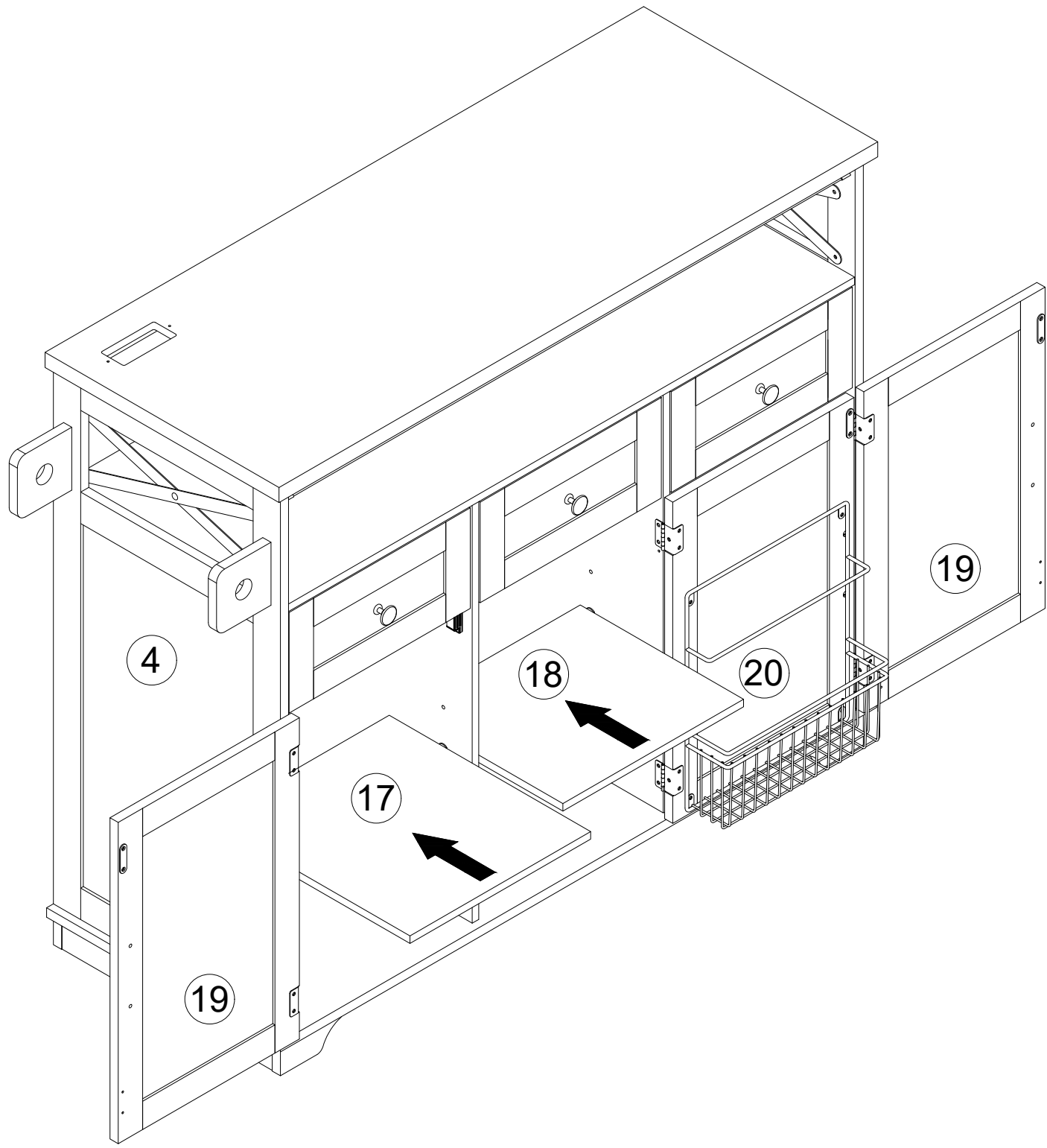

Mx4

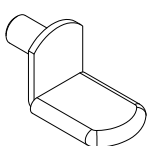

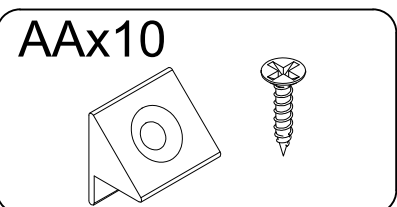
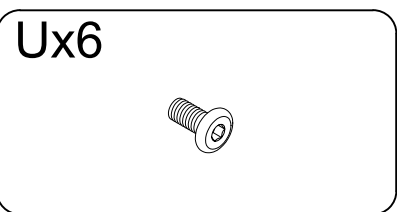
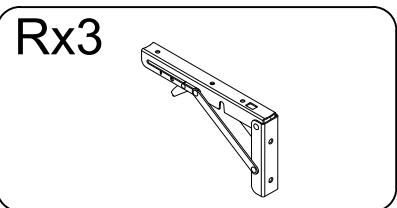
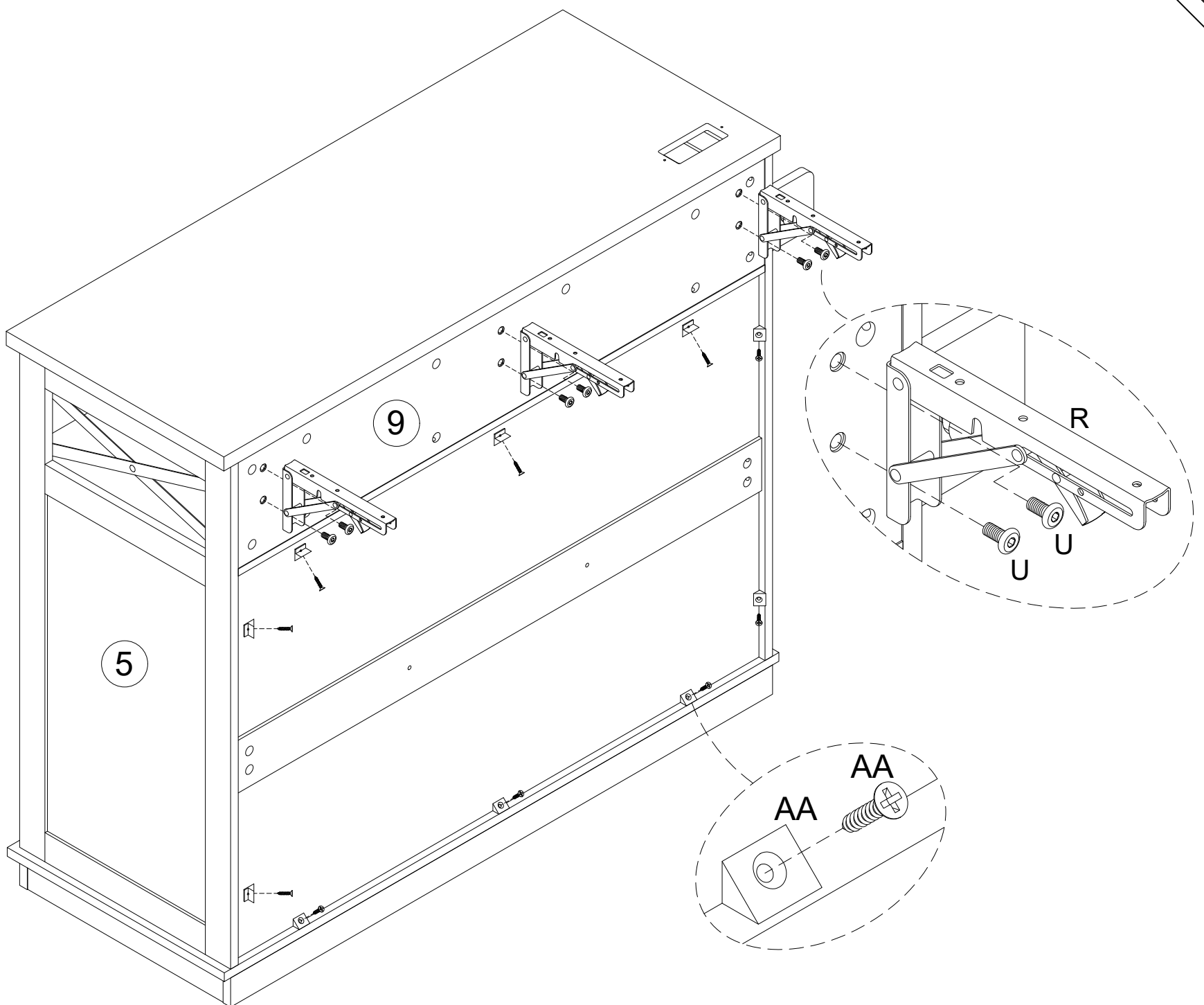
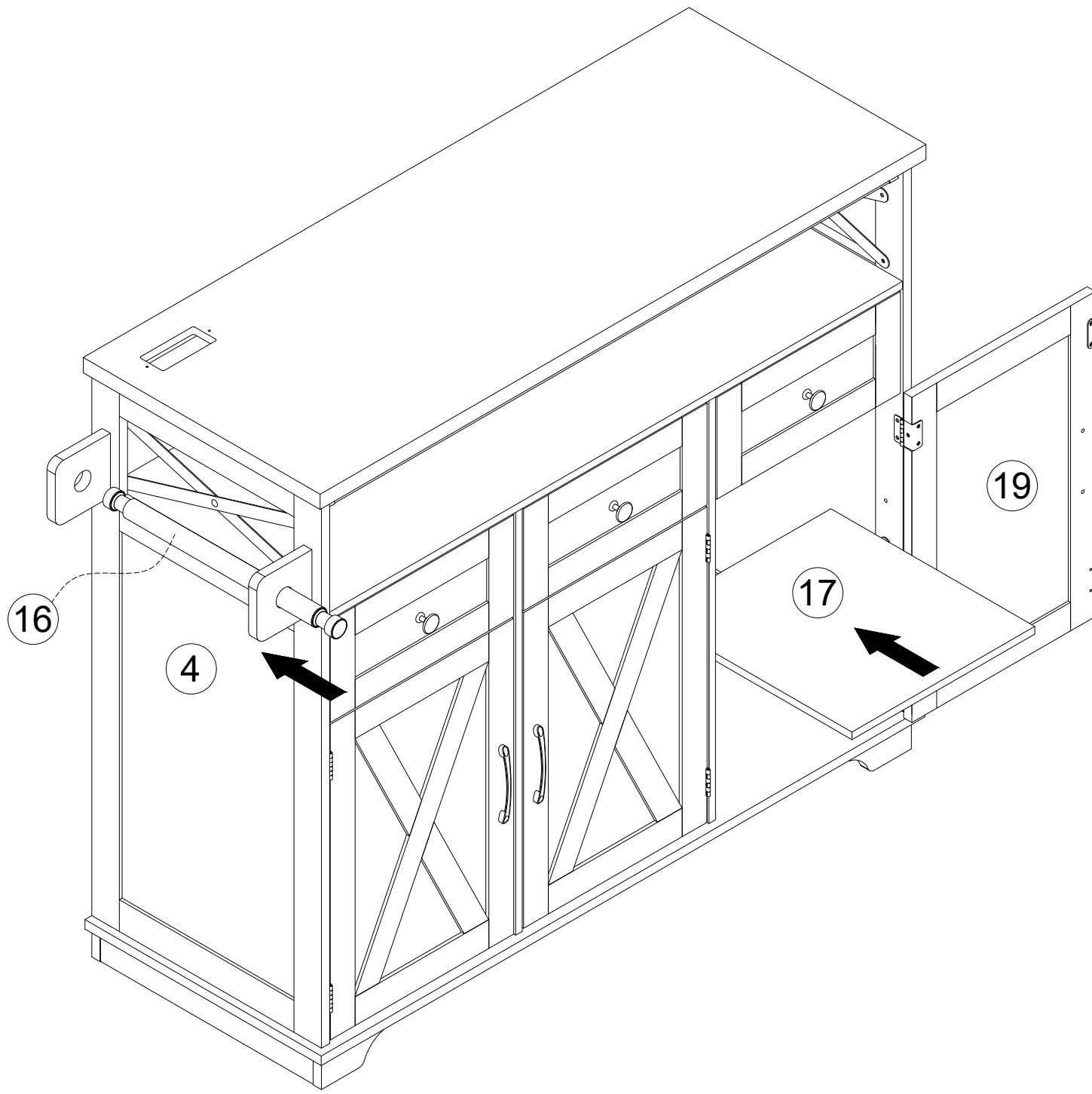

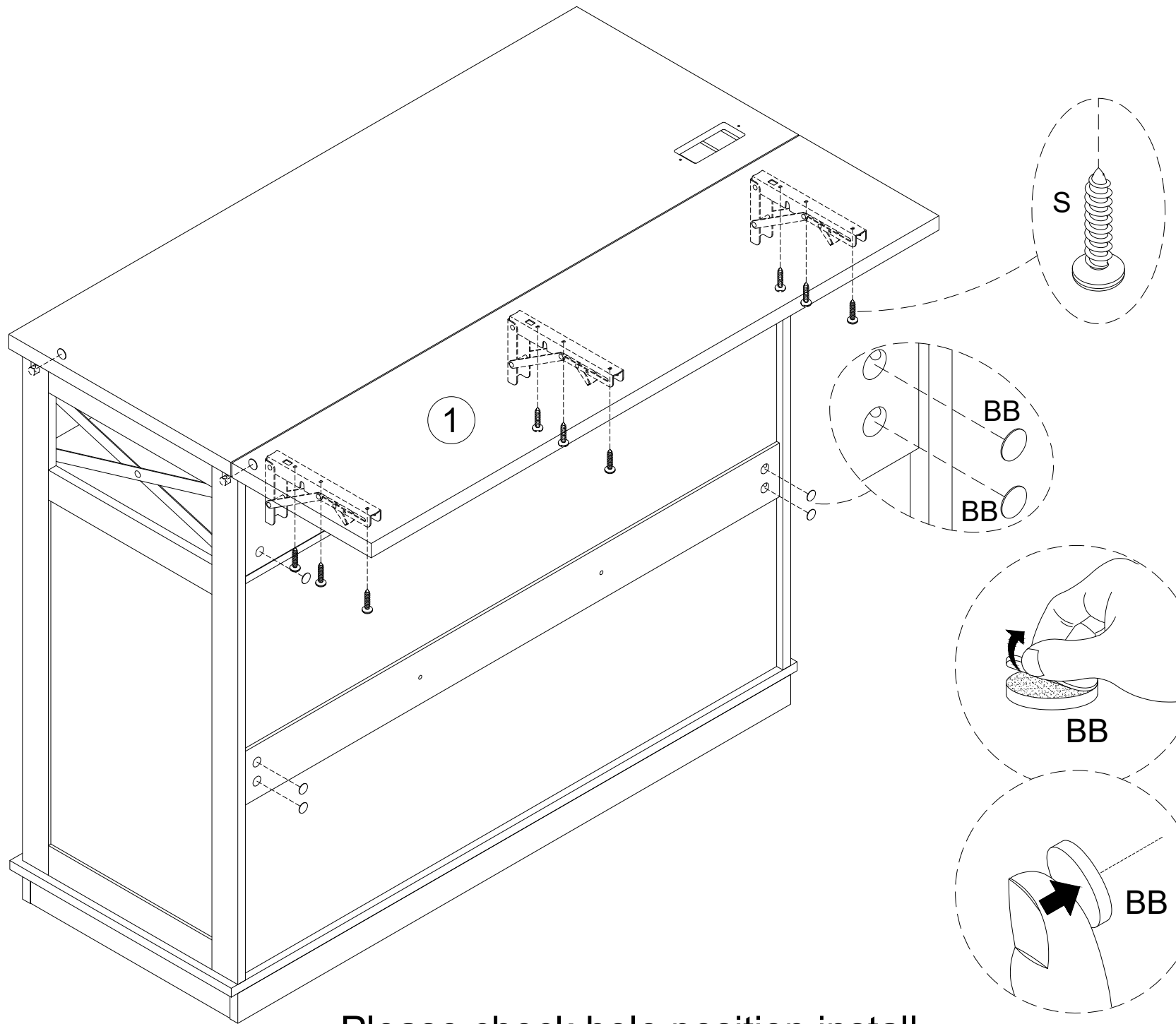

1

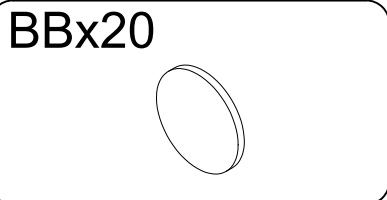
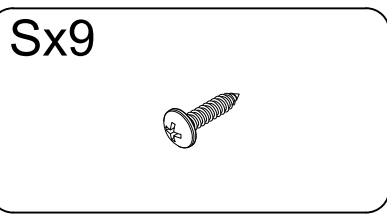

Please check hole position install

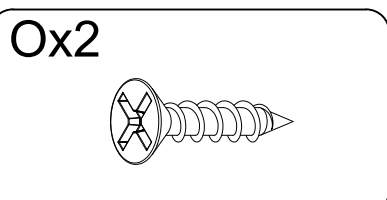
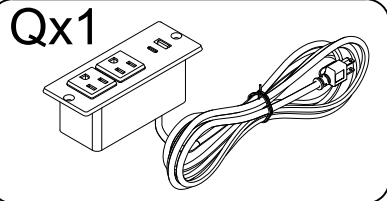
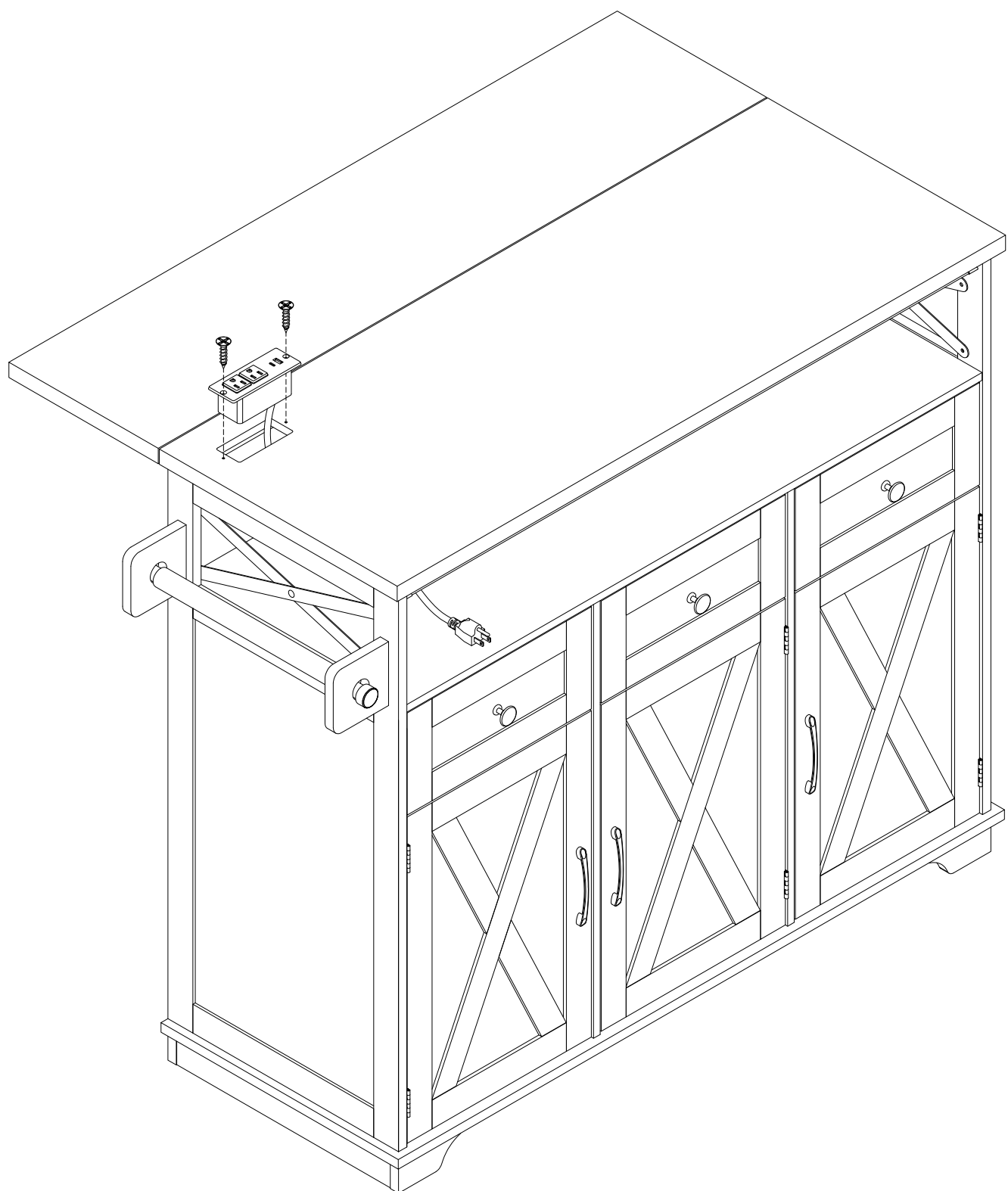



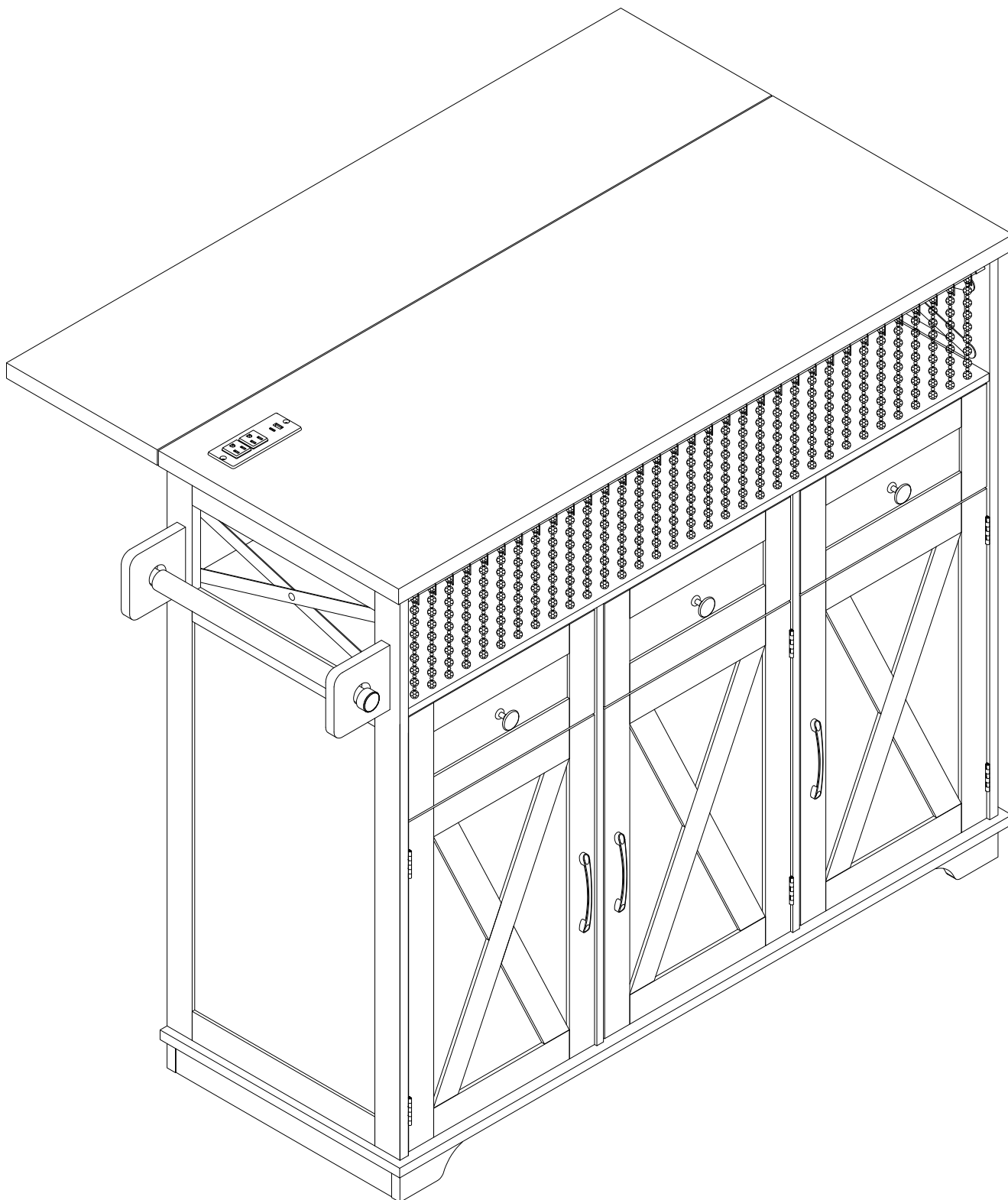
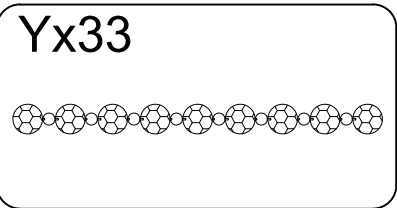
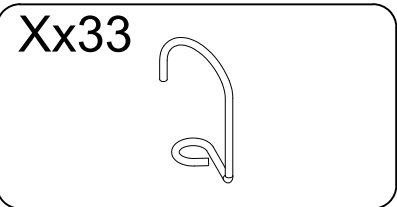
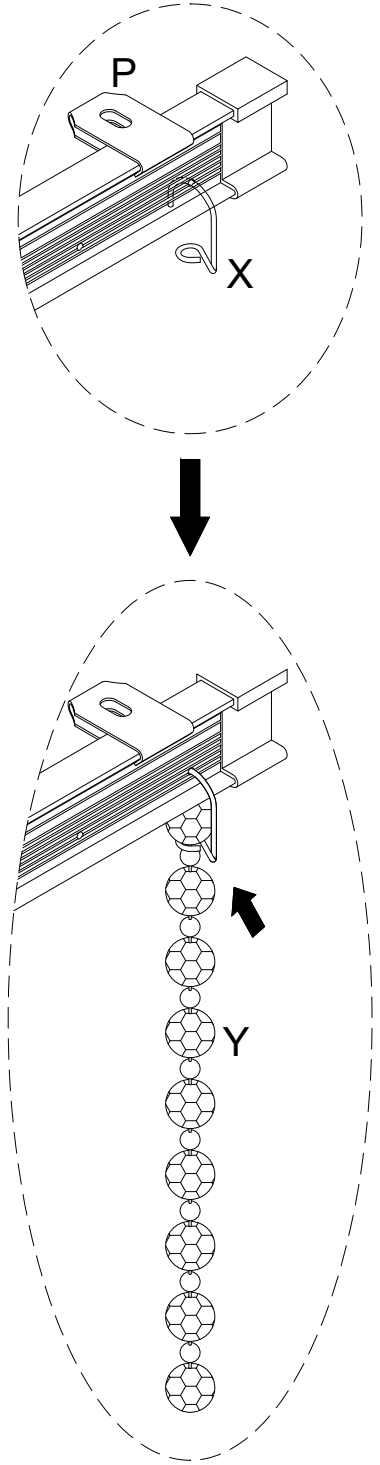
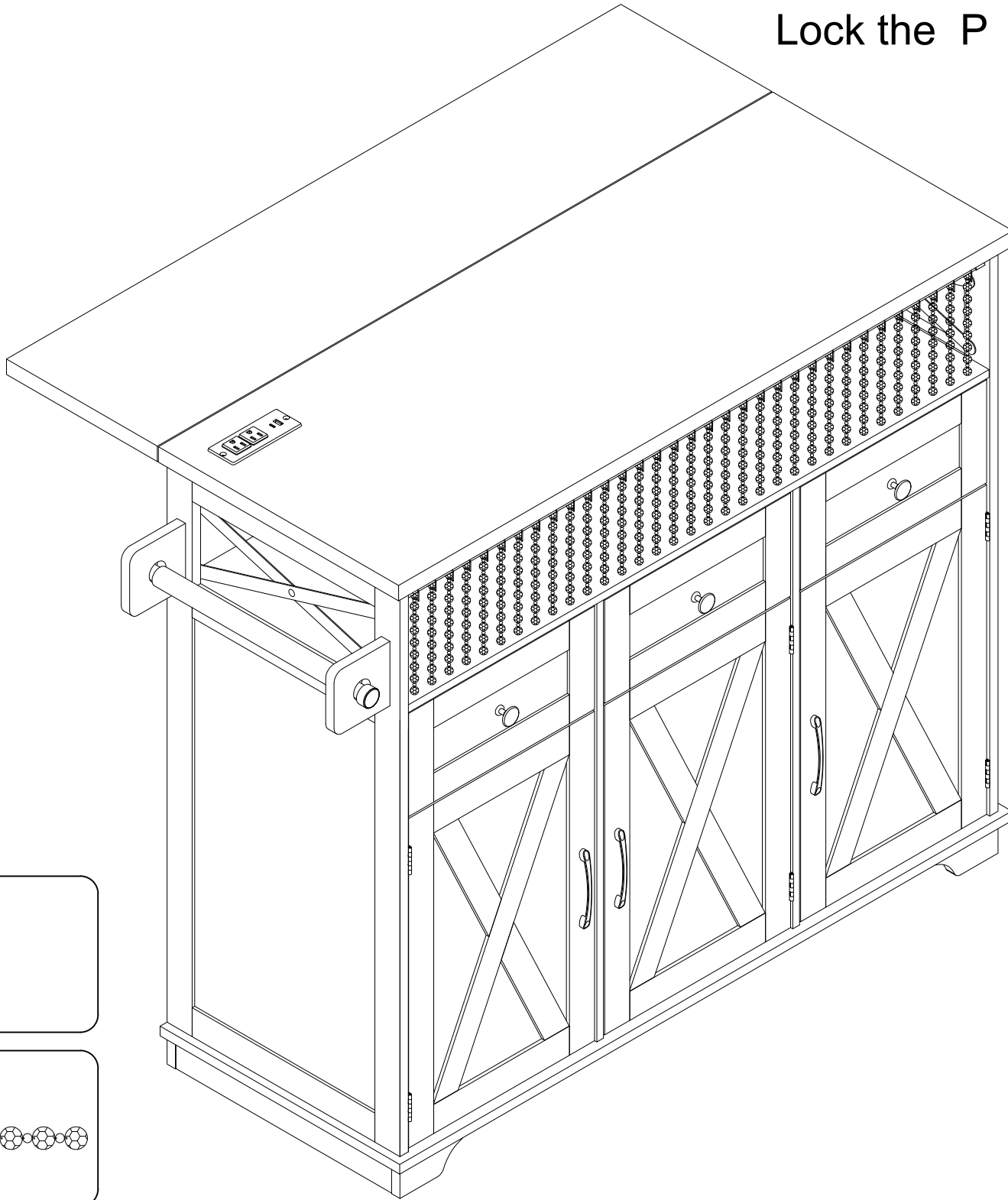







Lock the P screws to 99%



Assembly Instructions

Caution : You must read this before you proceed

Care & Maintenance

- ⊘  ● Not for commercial use. For residential use only.
 - ✓  ● Furniture may scratch floors. We recommend using furniture pads to protect your floors.
 - ⊘  ● Do not put hot items directly on furniture surface.
 - ⊘  ● Do not clean furniture with harsh cleansers or polish.
 - ⊘  ● Do not place furniture under direct sunlight.
 - ⊘  ● Do not place furniture near heating or cooling vents.
 - ⊘  ● Do not write on furniture without a padded barrier to protect the surface.
 - ⊘  ● Do not place furniture outside . For indoor use only.
 - ⊘  ● Stains may be removed with mild soap solution and damp cloth.
 - ⊘  ● Children should not climb or jump on the furniture.
- ✓  ● Dust and pick-up spills using a clean, non-colored, lint-free cloth.

Please look in carton for hardware packs and legs.
Sets often ship in multiple boxes and may arrive a day or two apart.