

Installation & Assembly

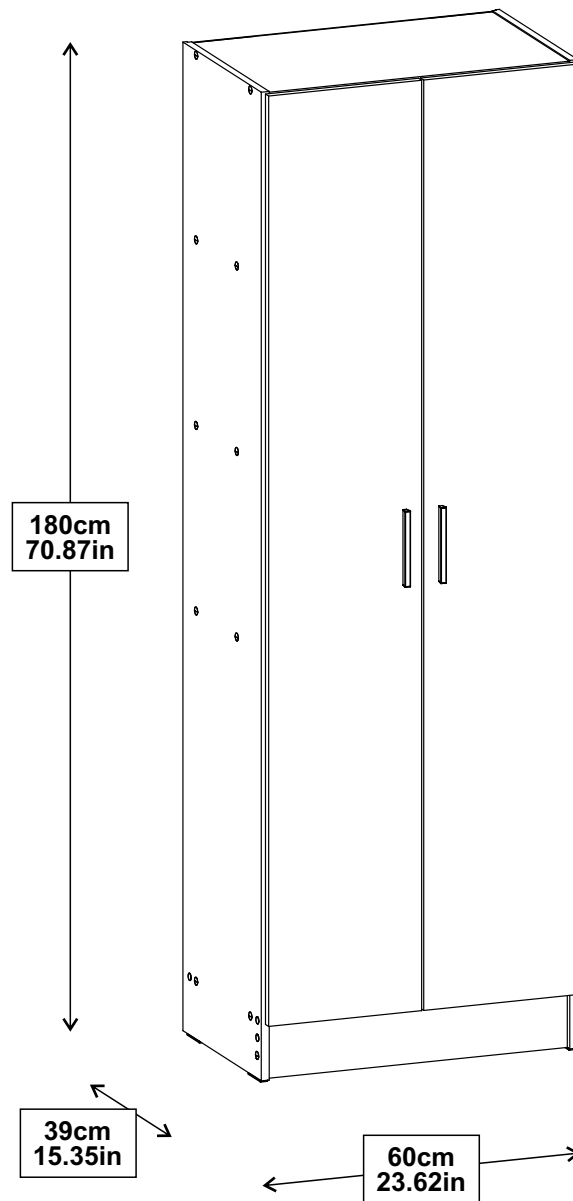

Tools needed to assemble the furniture: - Outils nécessaires pour assembler les meubles:

Werkzeuge, die für die Montage der Möbel benötigt werden: - Herramientas necesarias para armar el mueble:

Ferramentas necessárias para montar o móvel: - Strumenti necessari per assemblare il mobile:

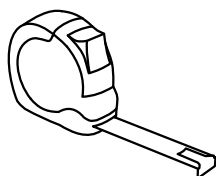
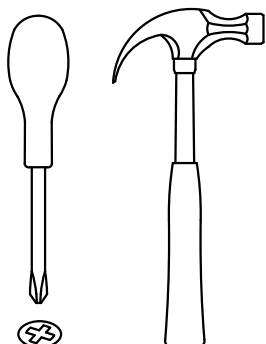

Comes with the product
Fournie avec le produit
Wird mit dem Produkt geliefert
Viene con el producto
Acompanha o produto
Accompagna il prodotto



The assembly must be done by two people.

L'assemblage doit être effectué par deux personnes.

Es wird empfohlen, dass zwei Personen den Artikel montieren.

El montaje debe ser efectuado por dos personas.

A montagem deve ser efetuada por duas pessoas.

Il montaggio deve essere effettuato da due persone.

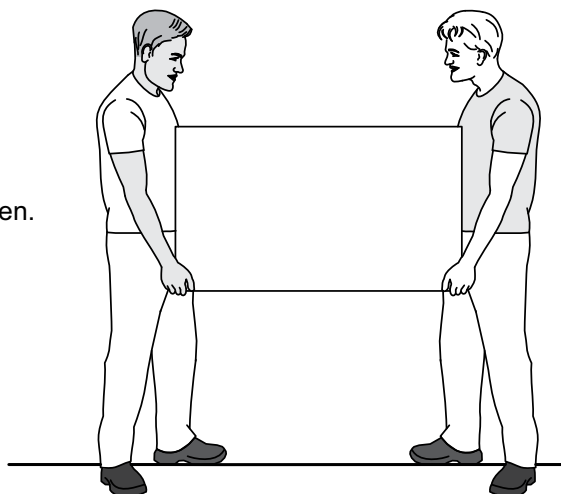

This product contain small parts, please,
keep out of reach of children.

Ce produit contient de petites pièces, s'il vous plait,
à conserver hors de portée des enfants.

Bitte halten Sie kleine Teile außerhalb der Reichweite von Kindern.

Este producto contiene piezas pequeñas,
mantener fuera del alcance de los niños.

Este produto contém peças pequenas, por favor,
mantenha fora do alcance das crianças.

Questo prodotto contiene piccole parti,
si prega di tenerle fuori dalla portata dei bambini.

In case of doubt, compare the hardware with the full-size images below.

En cas de doute, veuillez comparer le matériel avec les images en taille réelle ci-dessous.

Vergleichen Sie im Zweifelsfall die Schrauben mit den Abbildungen in Originalgröße.

En caso de dudas, compare las herrajes con las imágenes a seguir en tamaño real.

Em caso de dúvida, compare as ferragens com as imagens abaixo em tamanho real.

In caso di dubbio, confronta le ferramenta con le immagini sottostanti a grandezza reale.

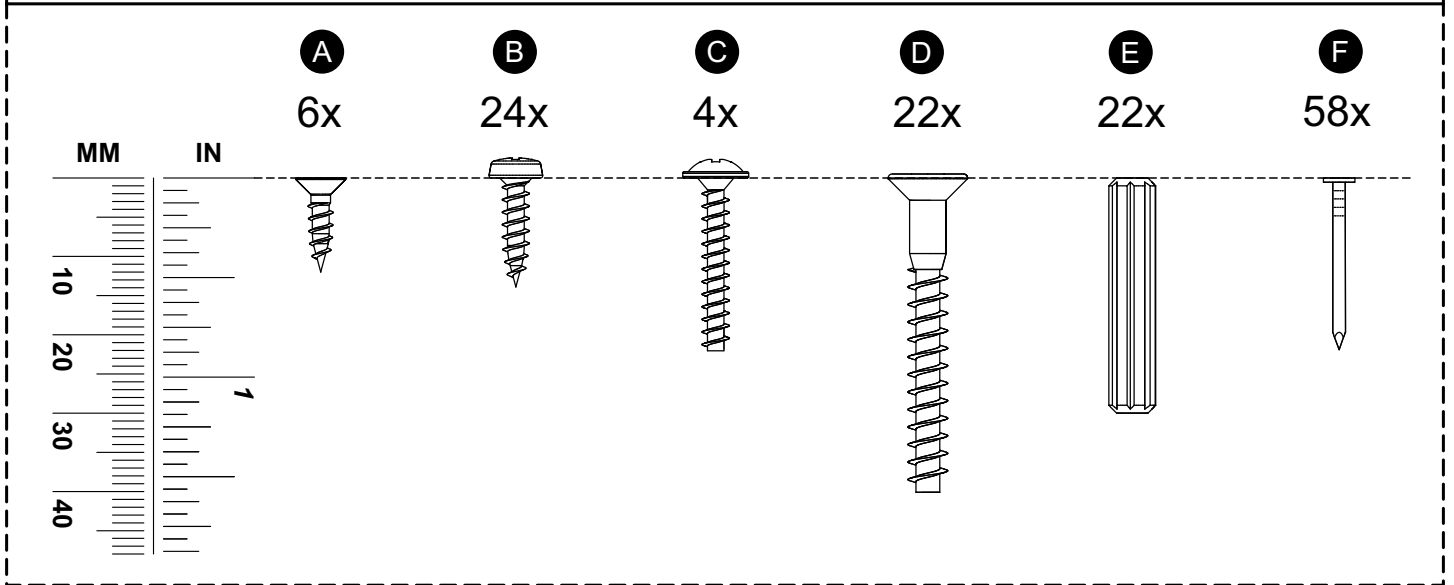
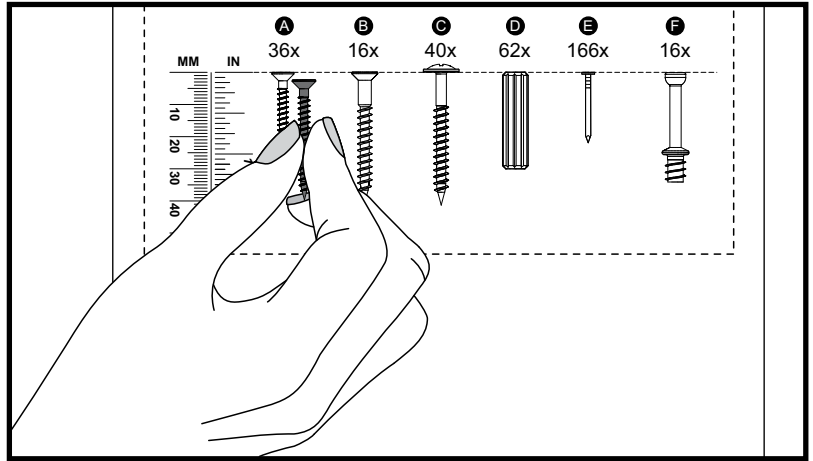

G
4x



H
6x



I
22x



J
4x



K
1x



L
1x

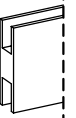

1674mm
65.91in

M
4x

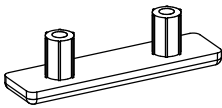

O
2x

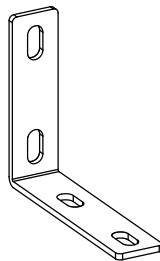

N
1x

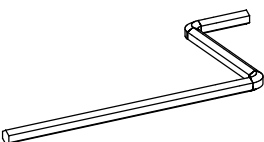

P
2x

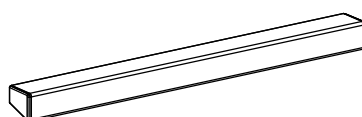

Q
6x

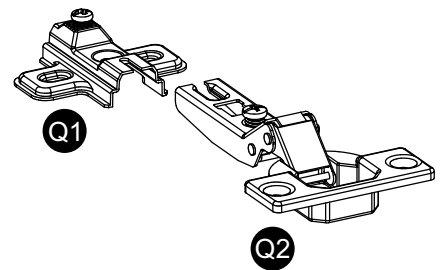

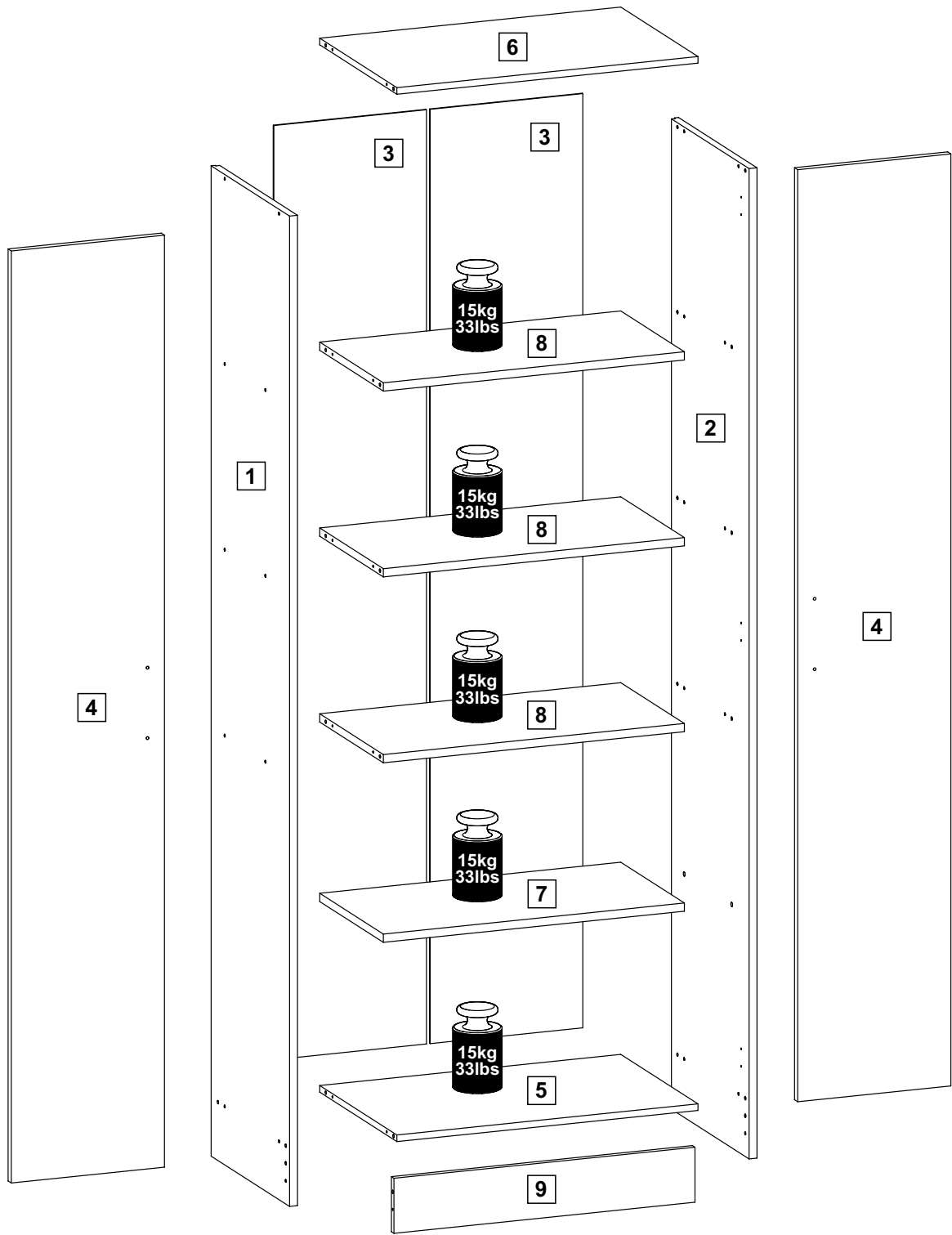

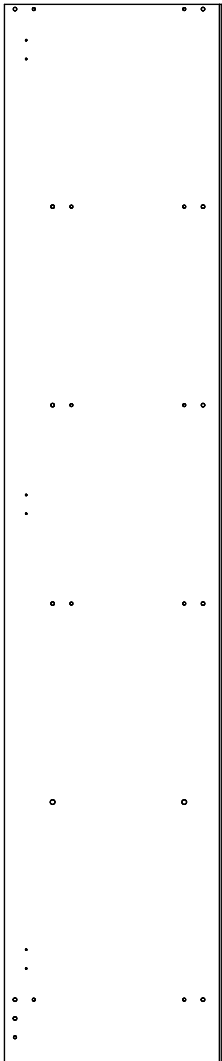

1 (370 x 1800 mm)
(14.57 x 70.87 in)

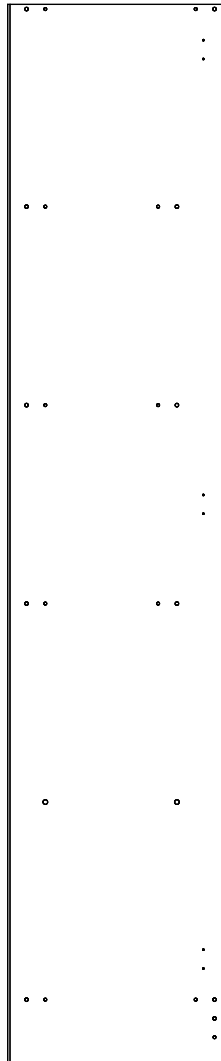

2 (370 x 1800 mm)
(14.57 x 70.87 in)



3 (289 x 1698 mm) - 2x
(11.38 x 66.85 in)

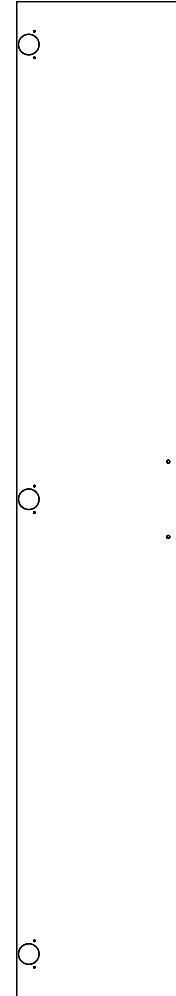

4 (290 x 1694 mm) - 2x
(11.42 x 66.69 in)

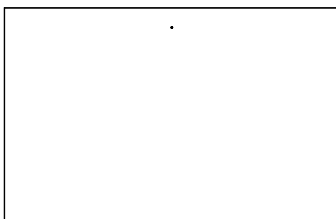

5 (364 x 570 mm)
(14.33 x 22.44 in)



6 (364 x 570 mm)
(14.33 x 22.44 in)



7 (300 x 570 mm)
(11.81 x 22.44 in)



8 (300 x 570 mm) - 3x
(11.81 x 22.44 in)

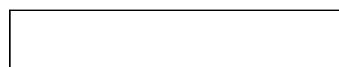

9 (100 x 570 mm)
(3.94 x 22.44 in)

ATTENTION - AVERTISSEMENT - ACHTUNG - ATENCIÓN - ATENÇÃO - ATTENZIONE

Assemble the furniture on a clean and flat surface and cover it with the cardboard of the packaging.

Assemblez le meuble sur une surface propre et plane et couvrez-le avec le carton de l'emballage du produit.

Um Beschädigungen zu vermeiden, montieren Sie den Artikel auf einer weichen, sauberen Unterlage.
Tipp: Legen Sie den Artikel auf dem Verpackungskarton.

Montar el mueble sobre una superficie limpia y plana y cubrirlo con el cartón del embalaje del producto.

Montar o móvel sobre uma superfície limpa e plana e forrá-la com o papelão da embalagem do produto.

Montare il mobile su una superficie pulita e piana e rivestirla con il cartone d'imballaggio del prodotto.

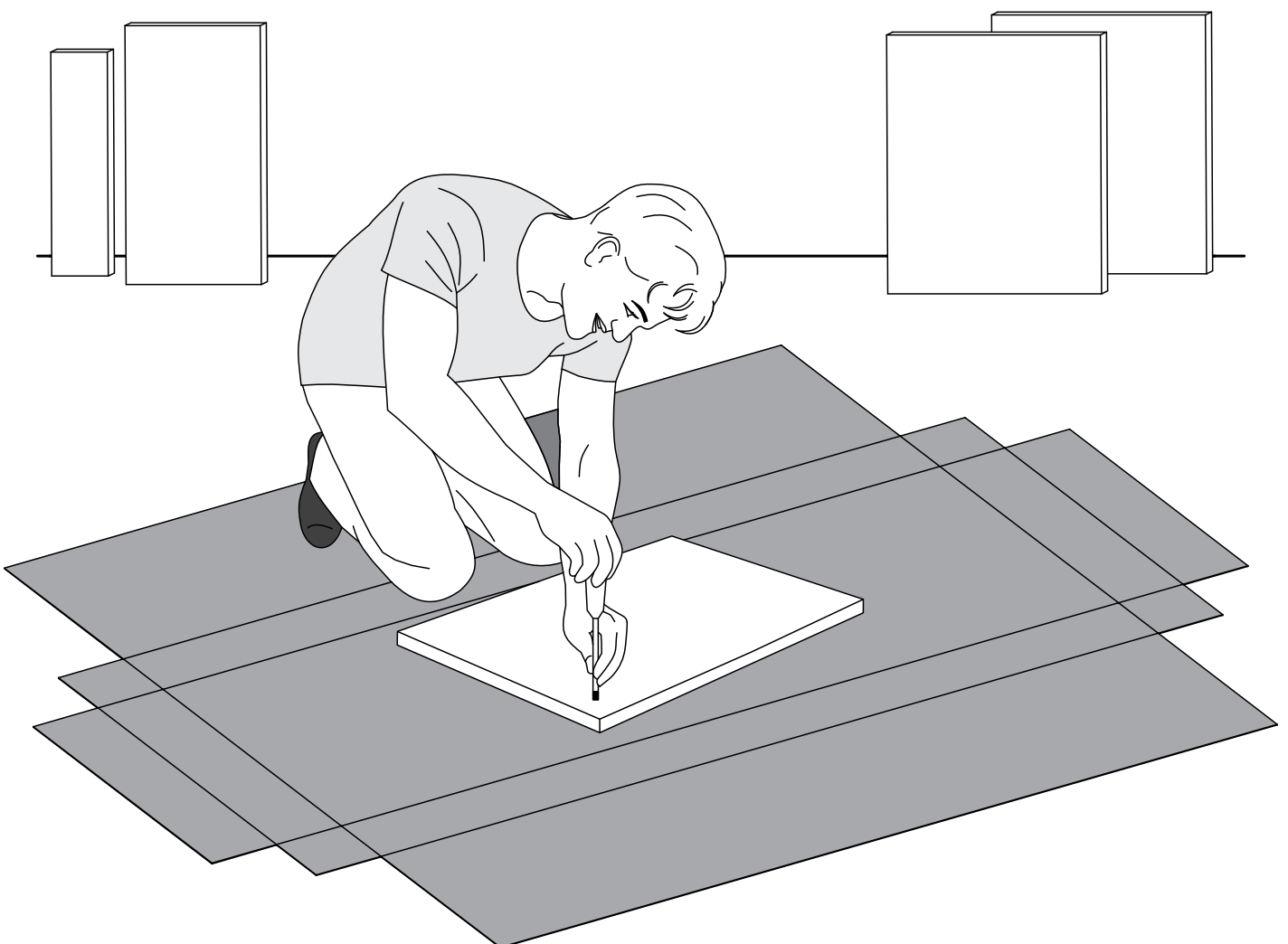
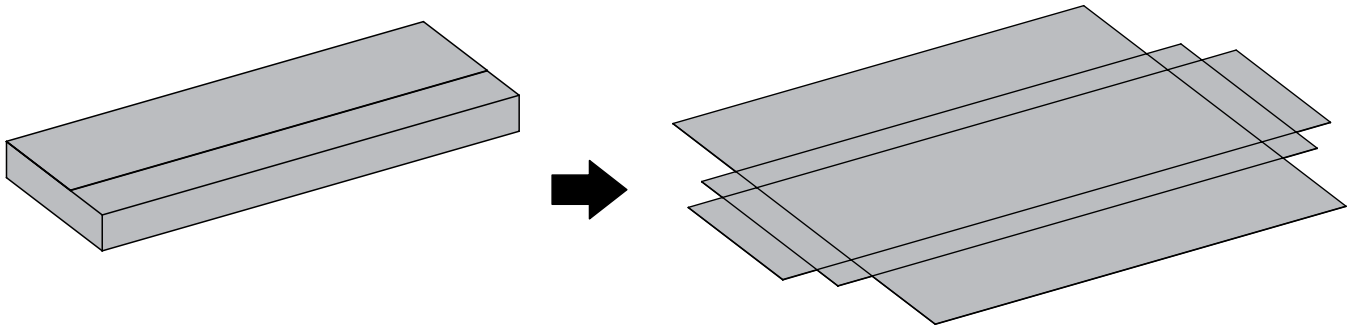

1

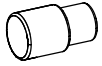
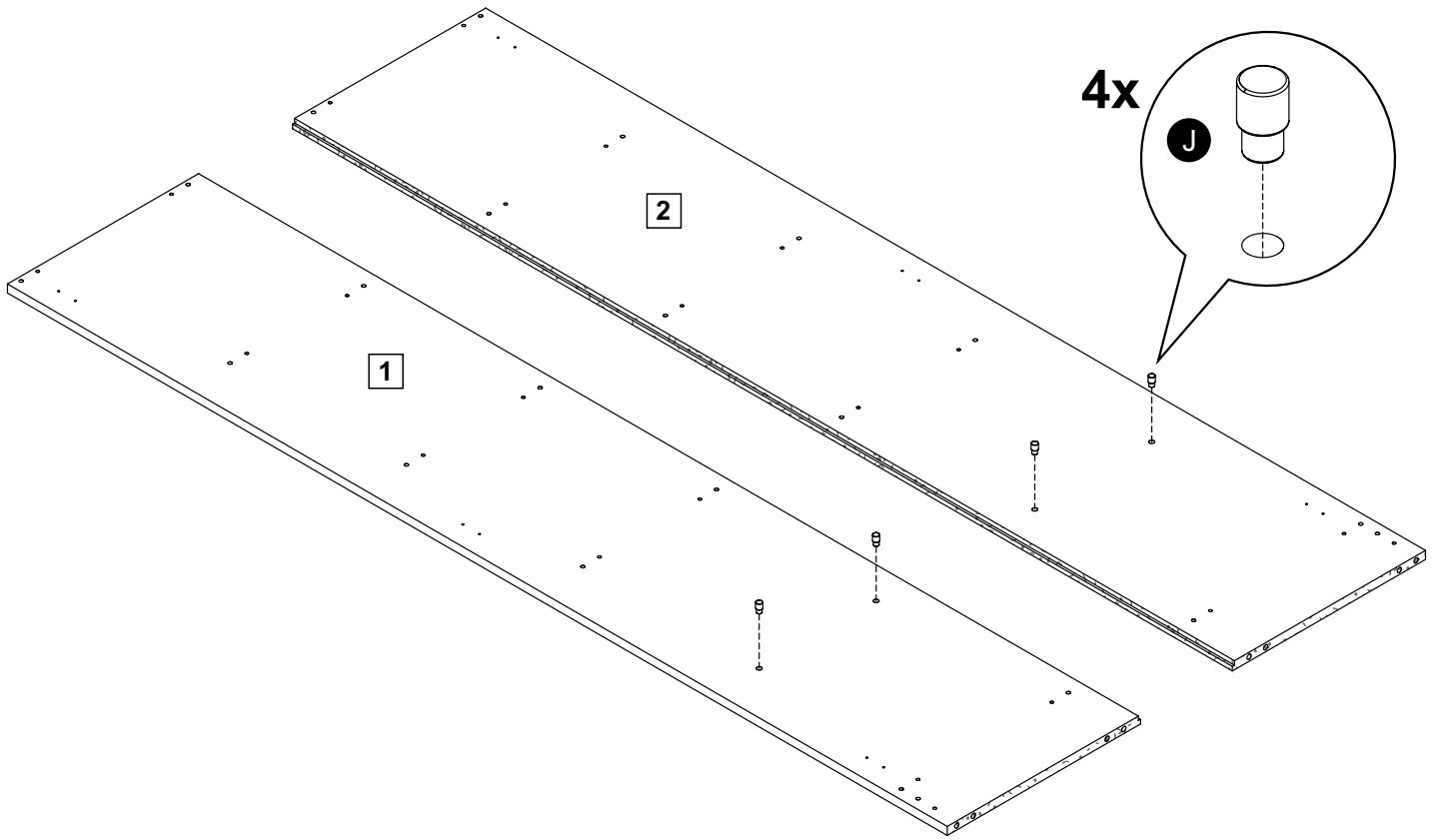
J**4x**

2

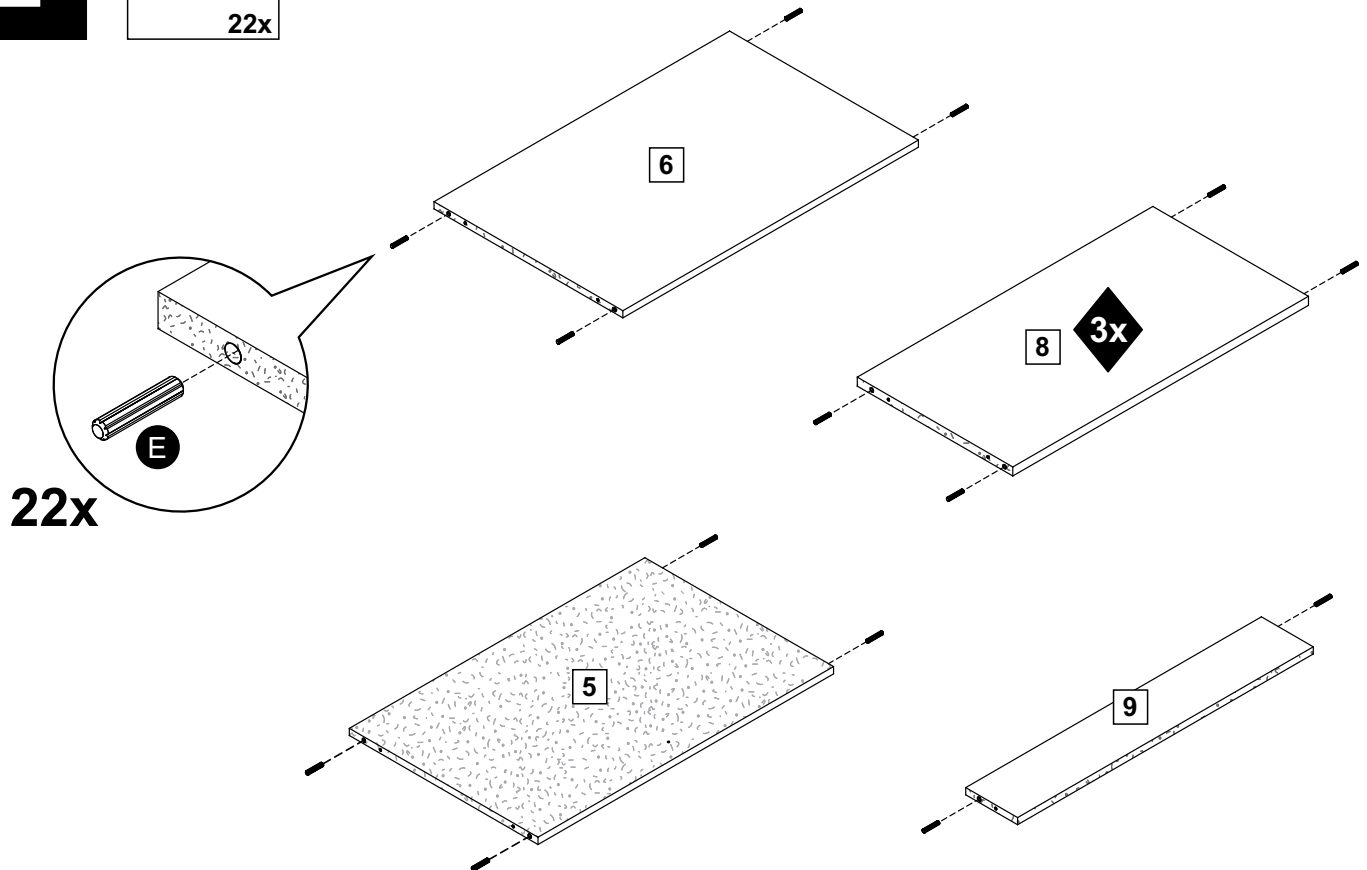
E**22x**

3

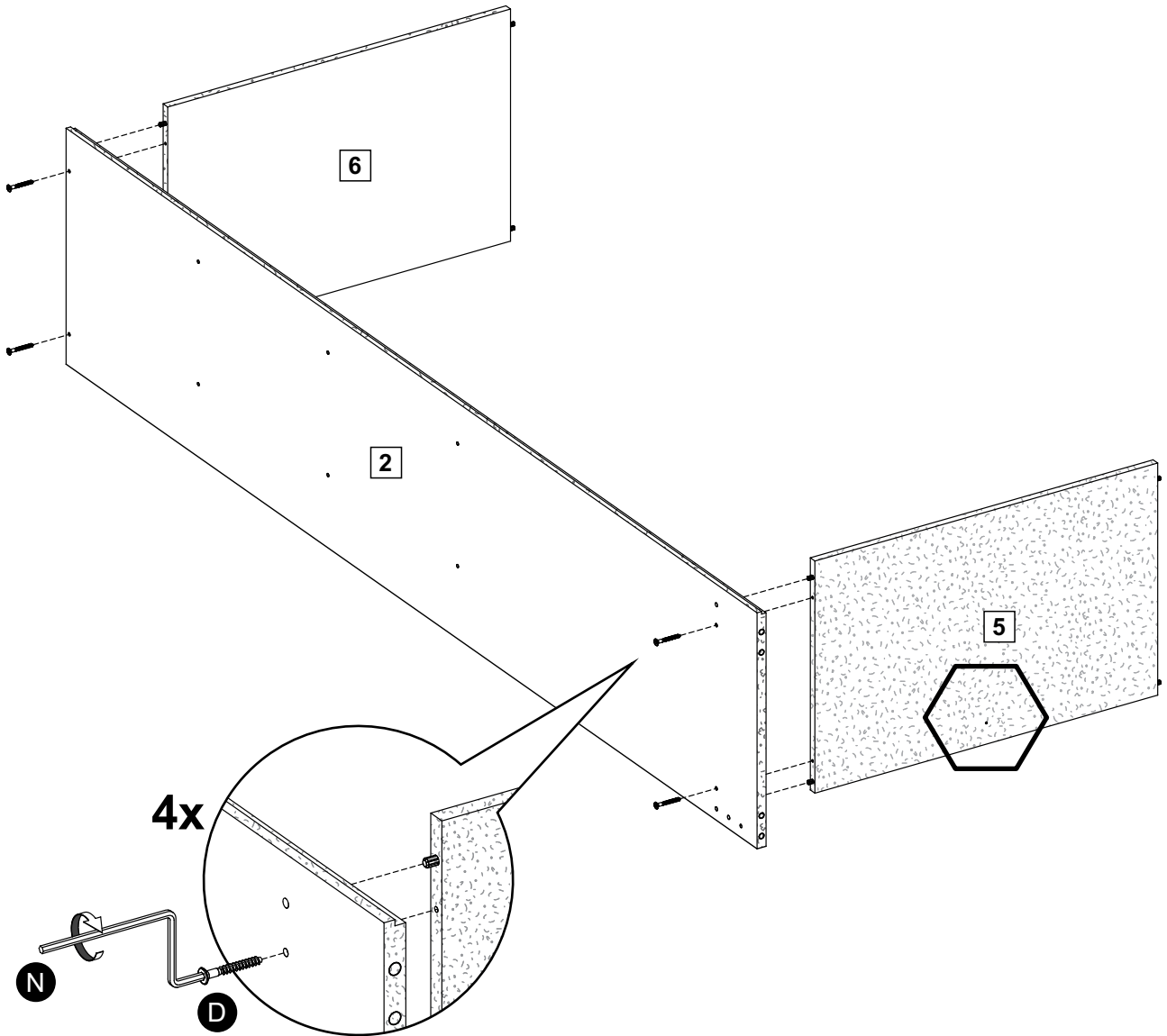
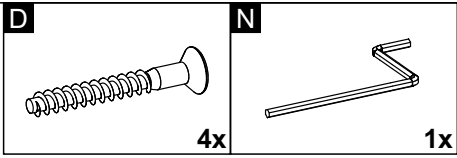

4

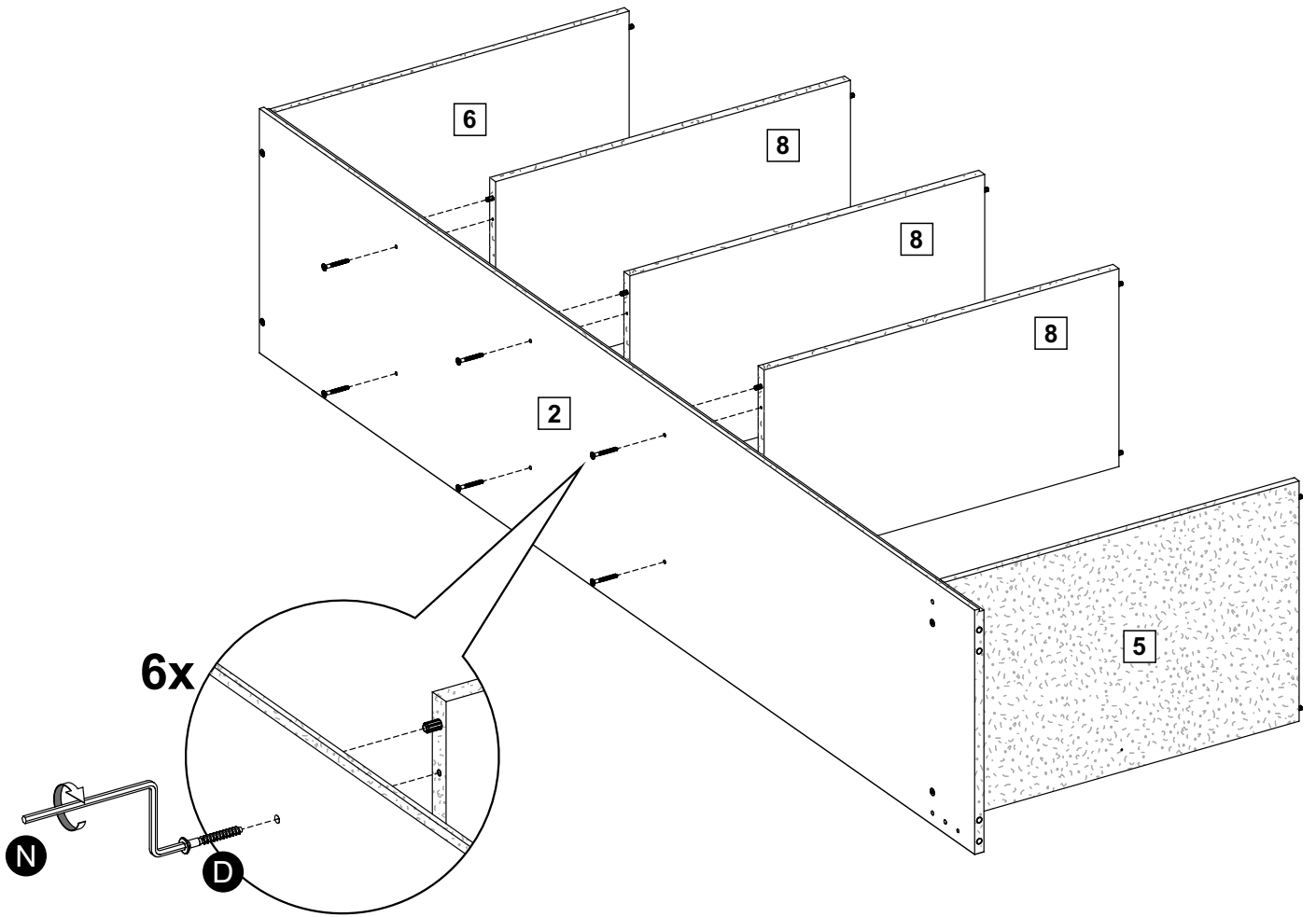
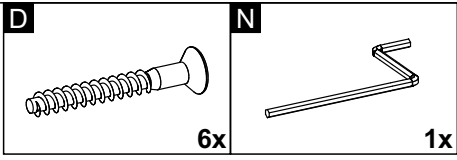

5

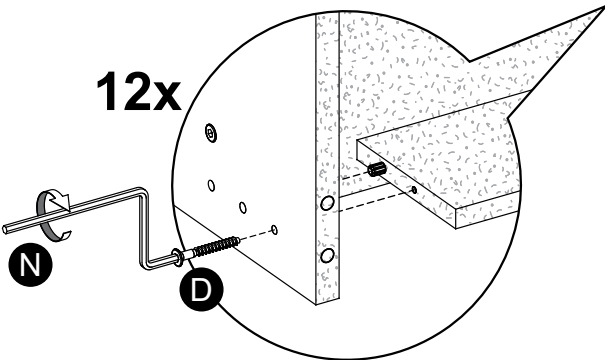
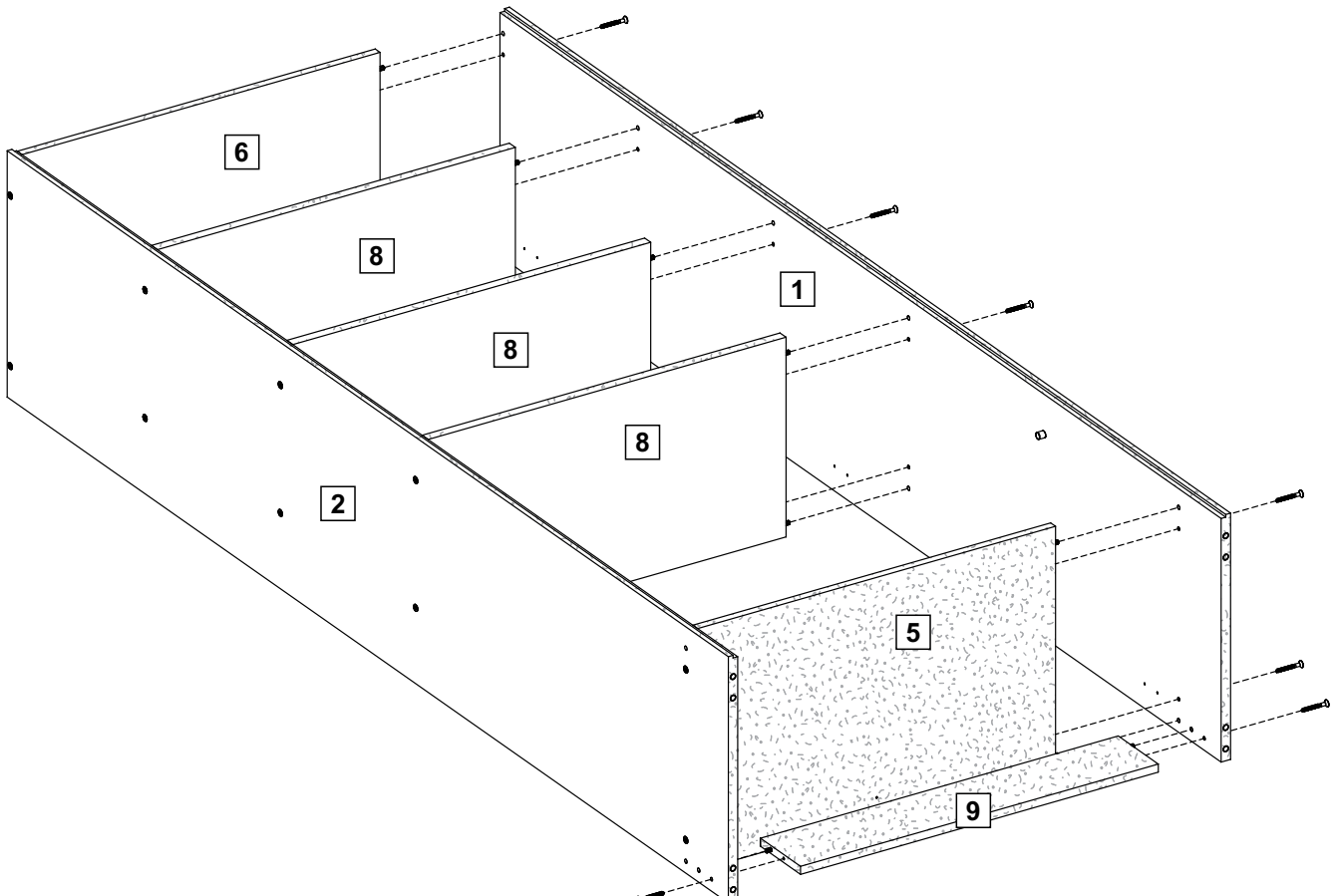
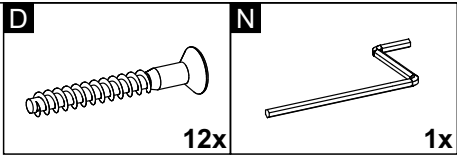

6

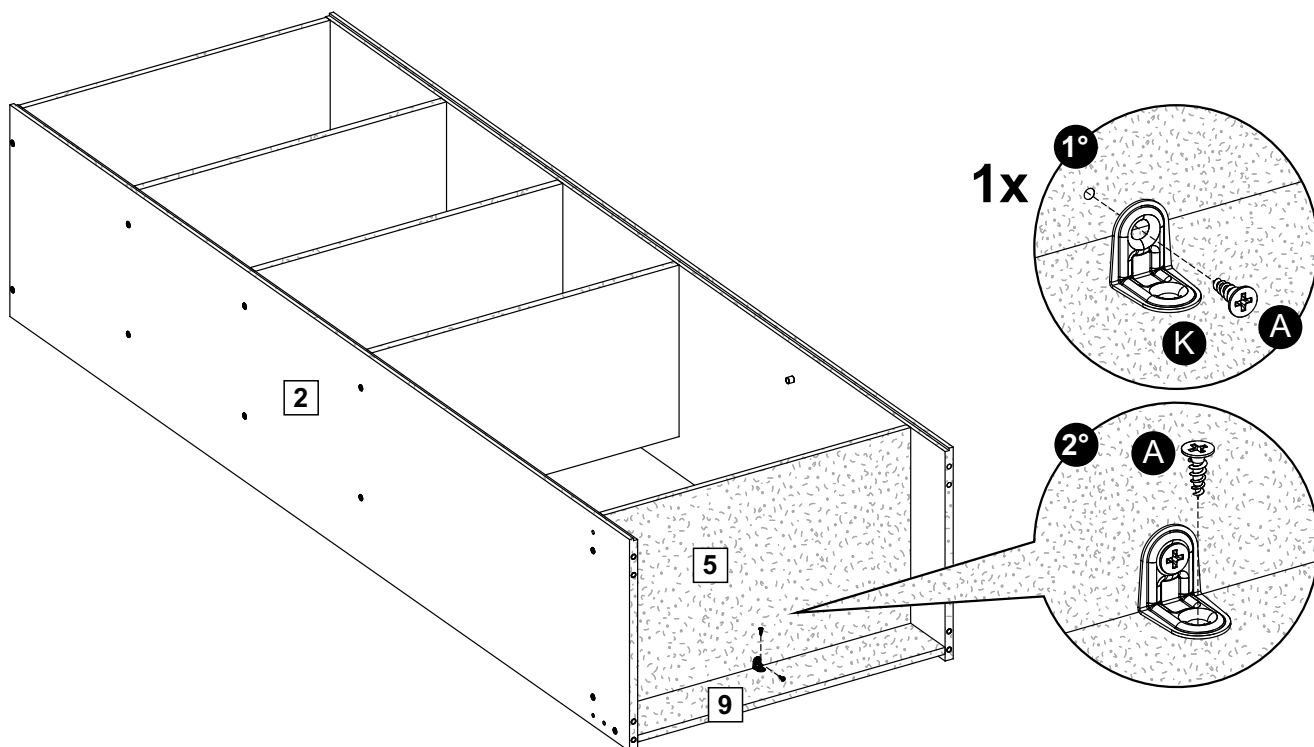
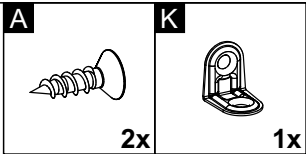

7

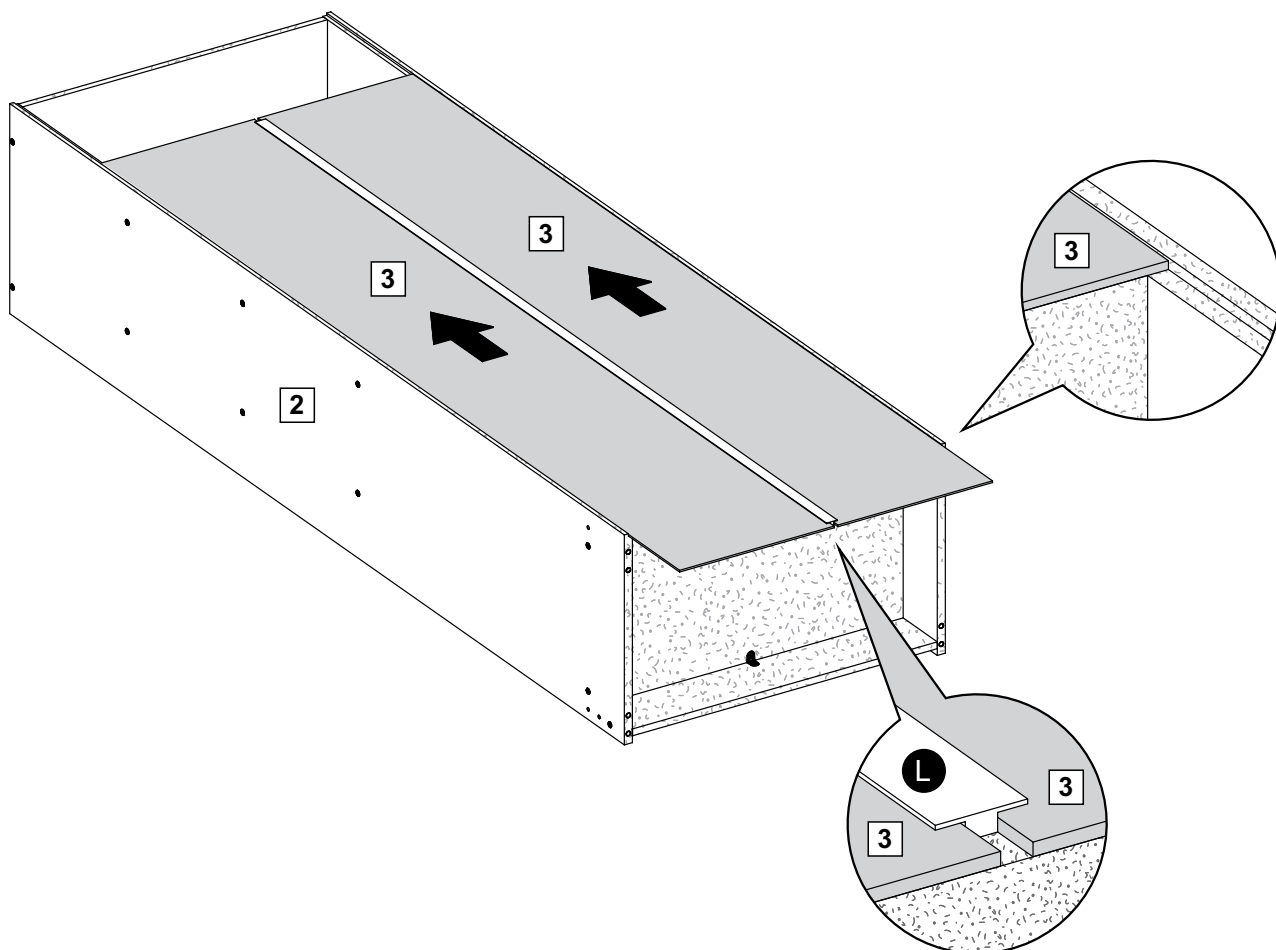
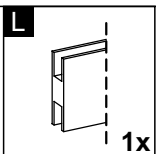

8

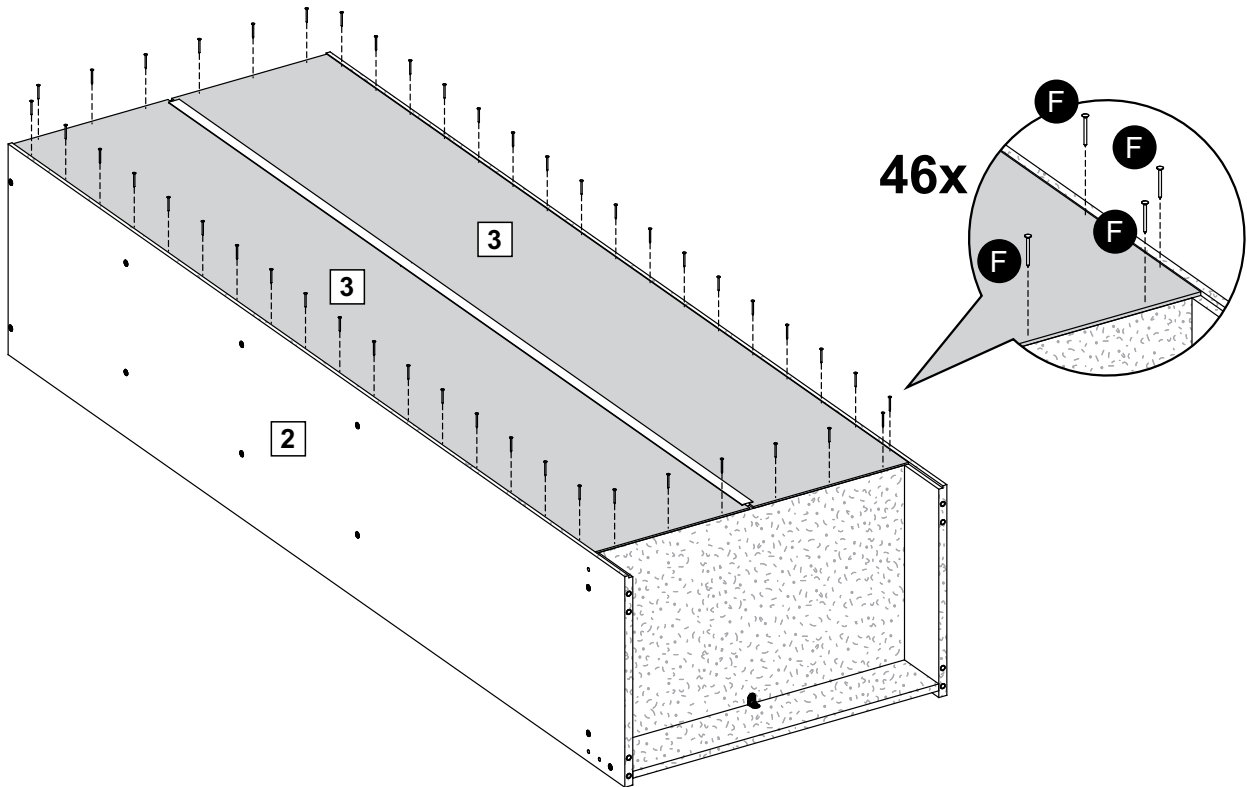
F**46x**

9

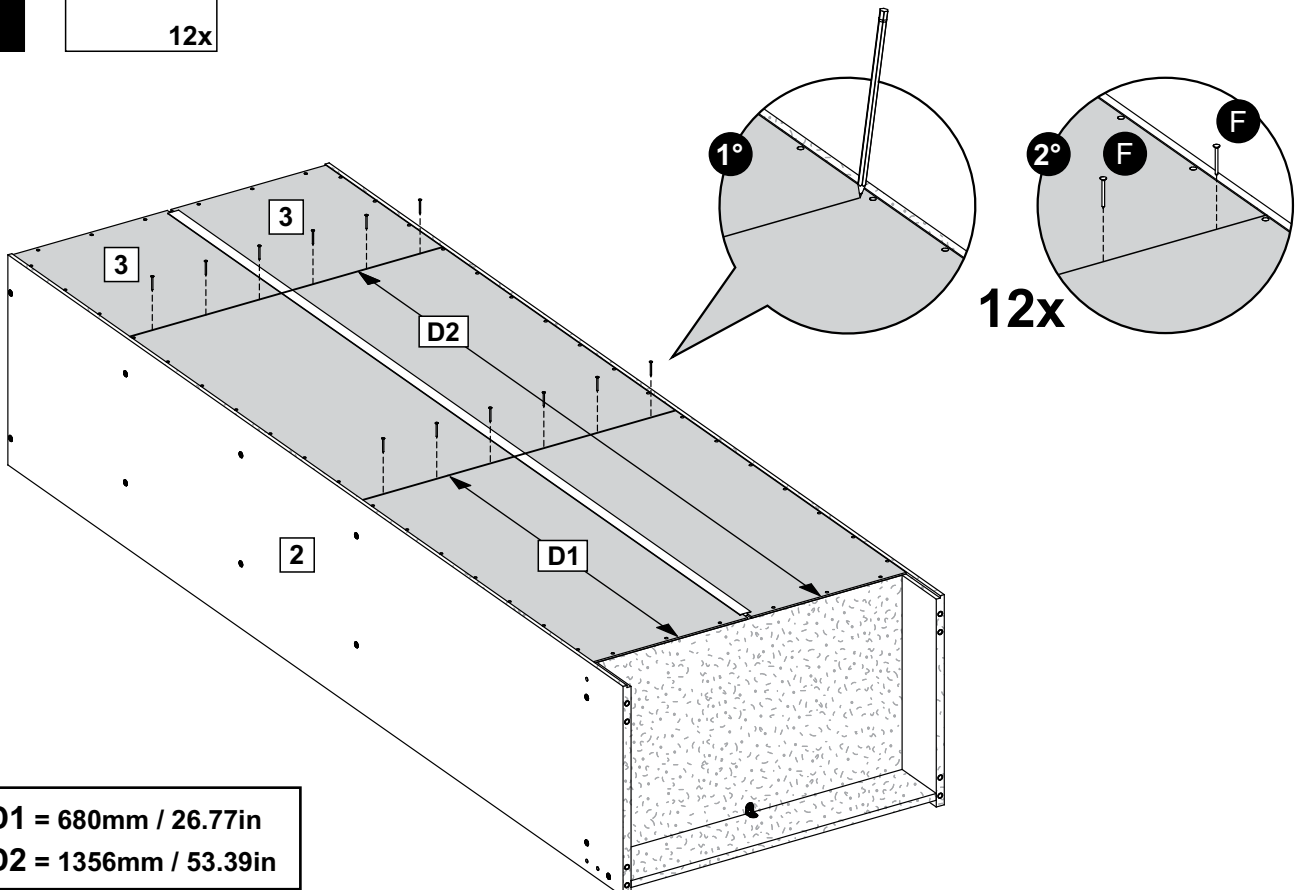
F**12x**

10

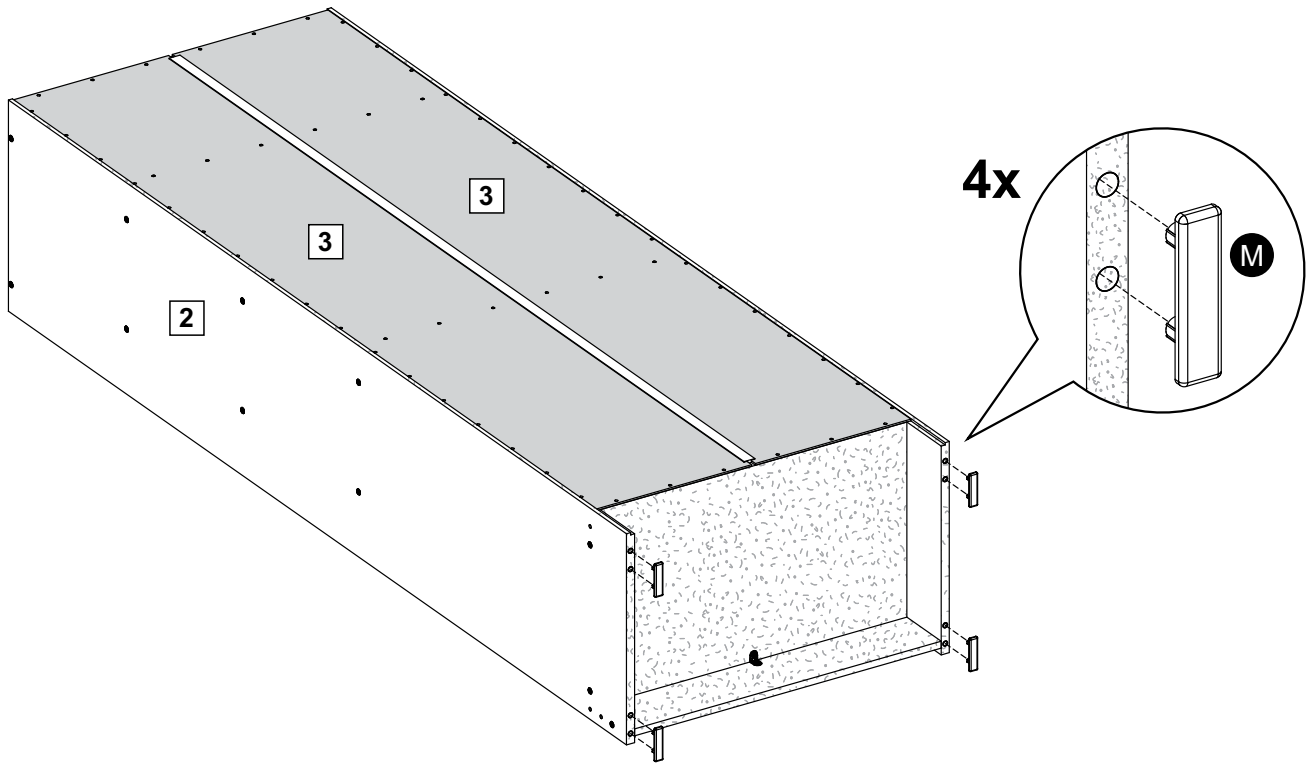
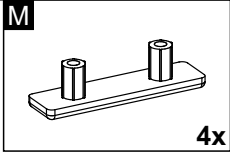

11

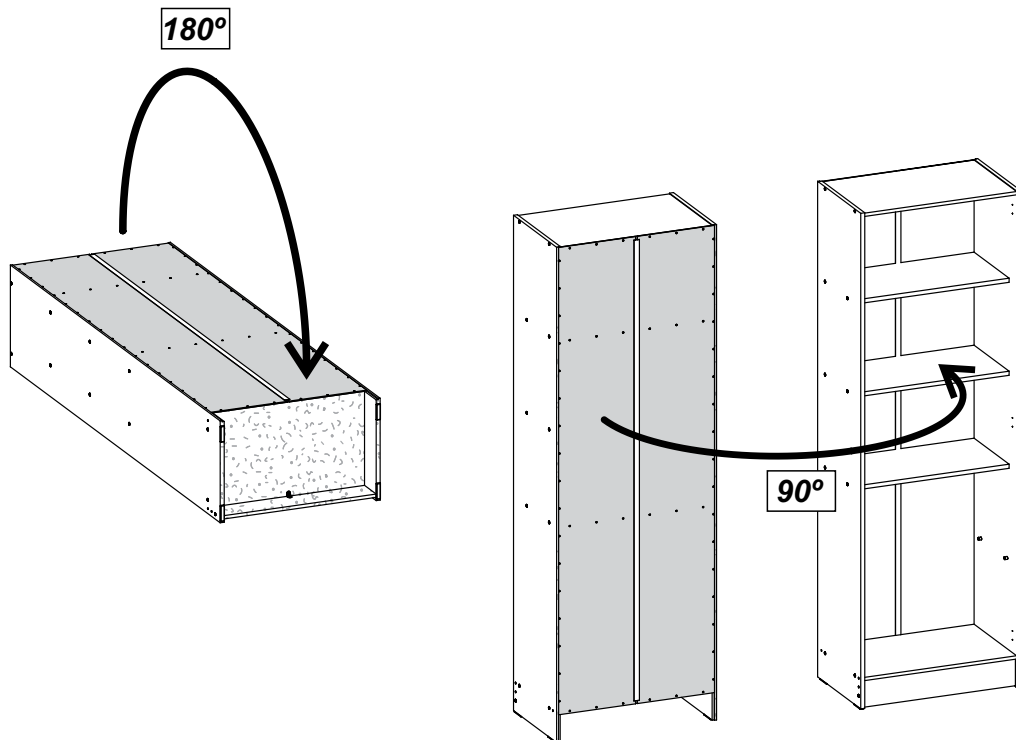

12

B

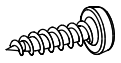

12x

Q2

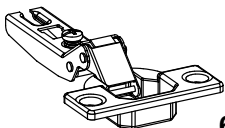

6x

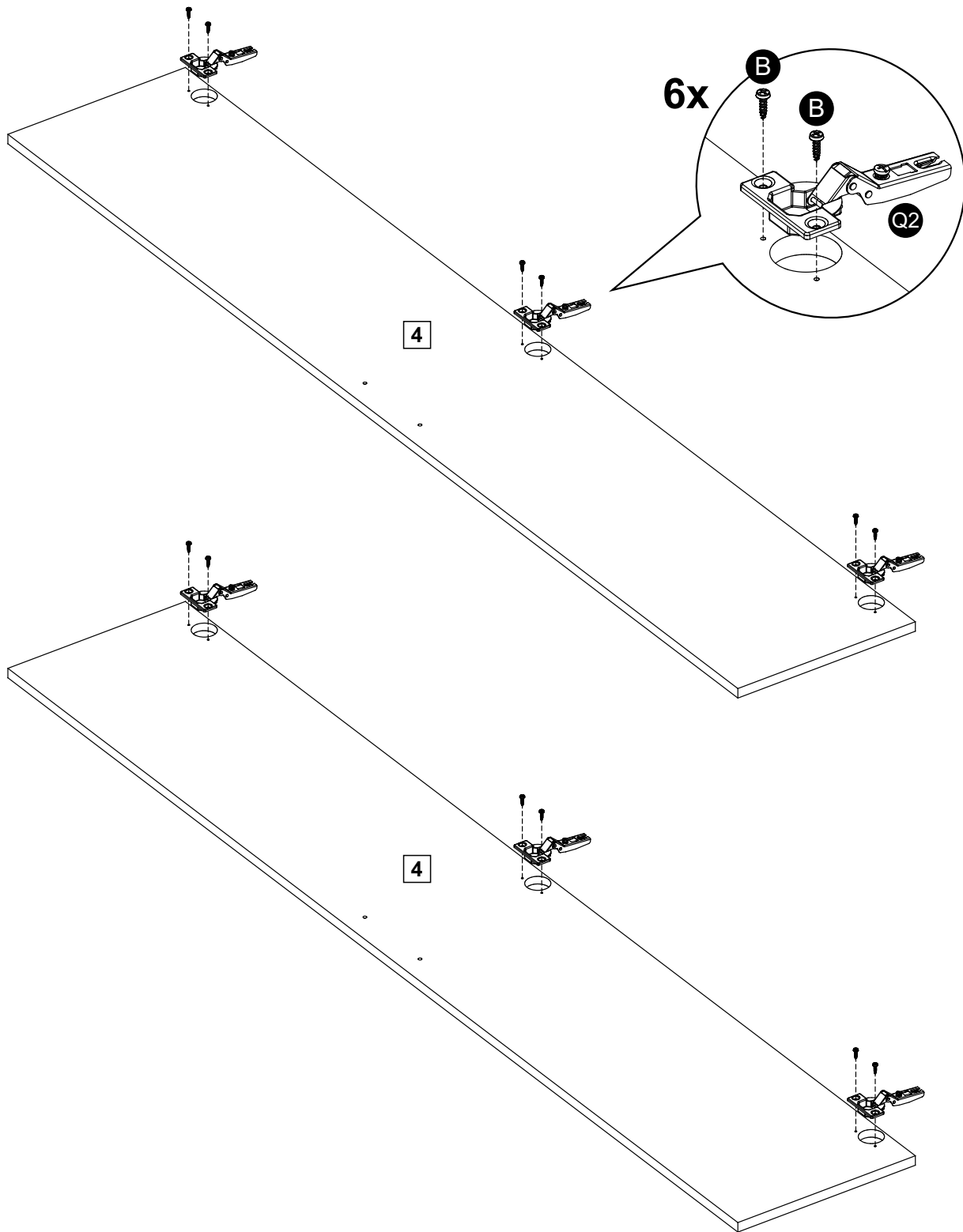

13

B



12x

Q1



6x

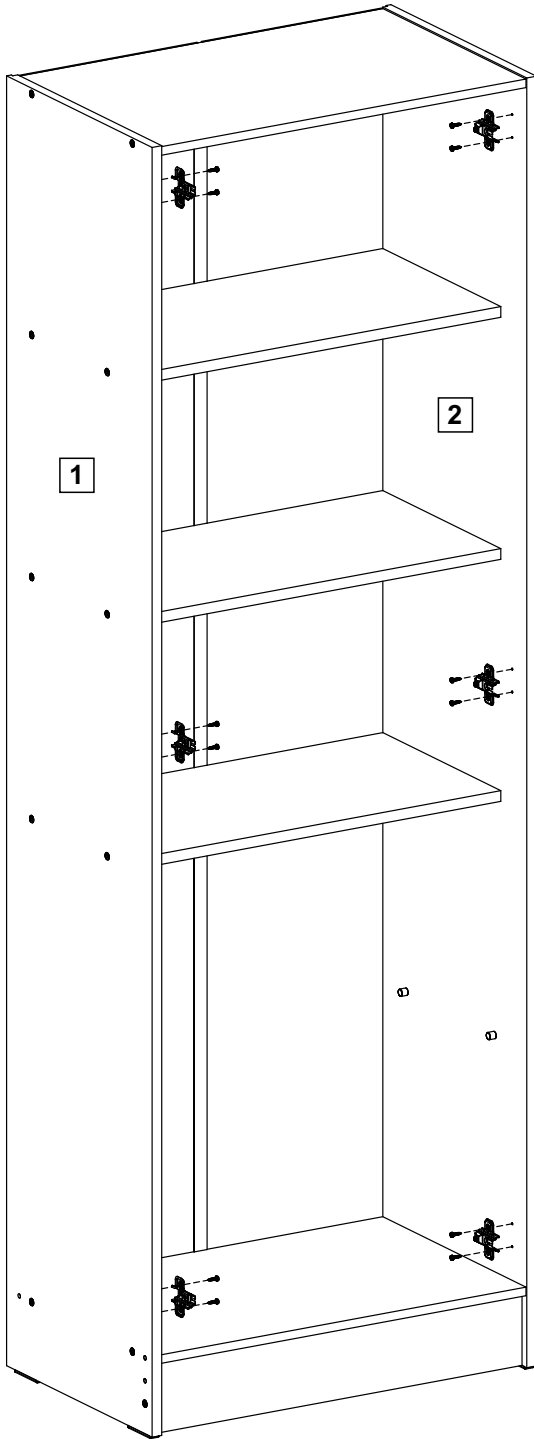

6x

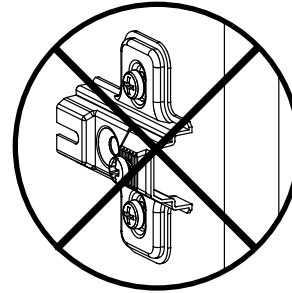
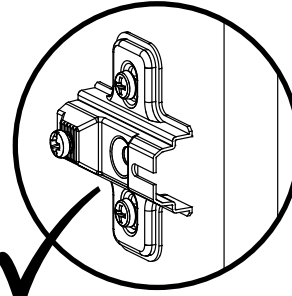
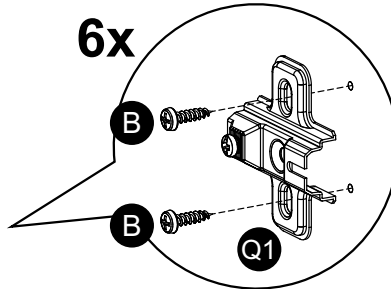

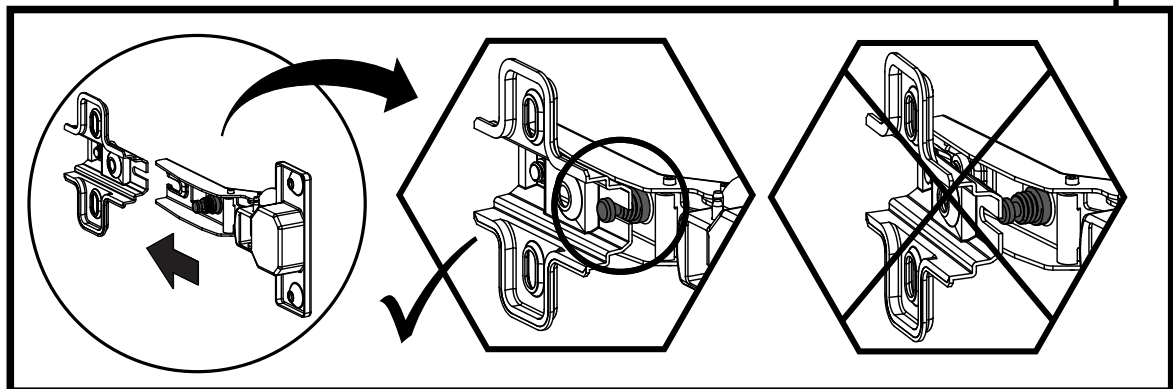
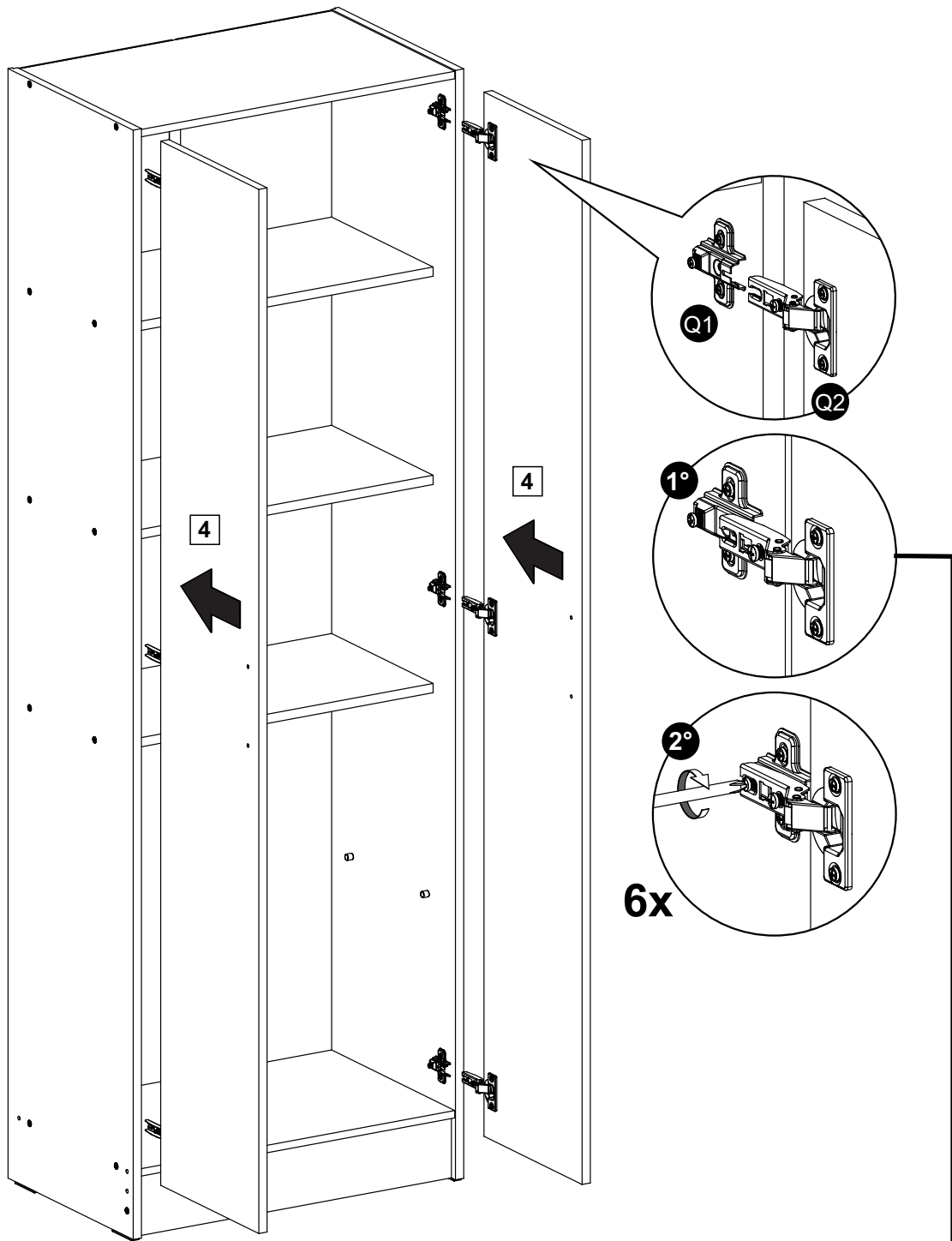

15

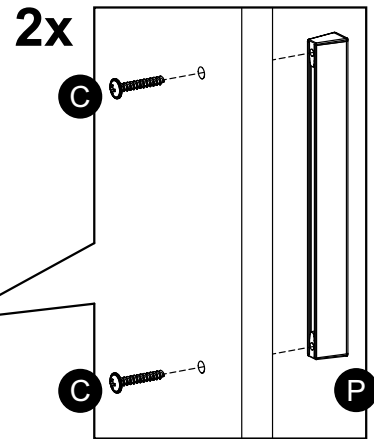
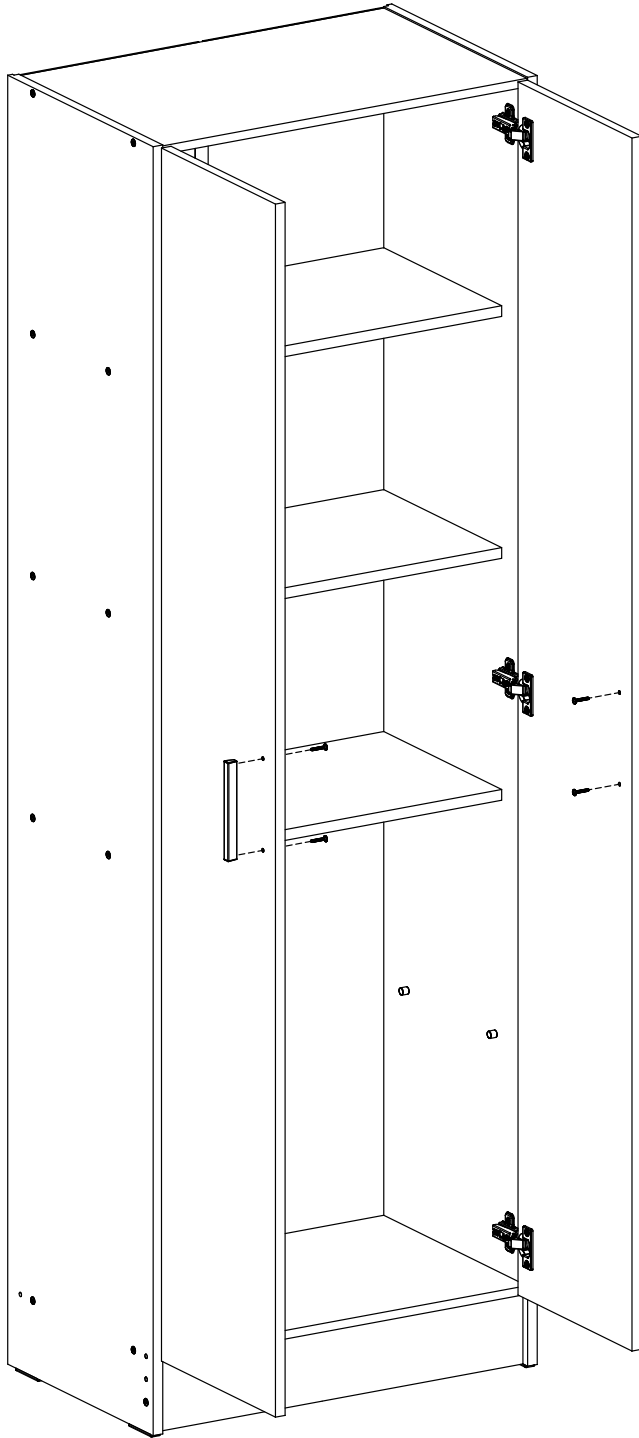
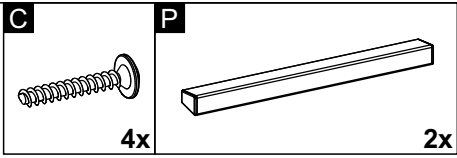

16

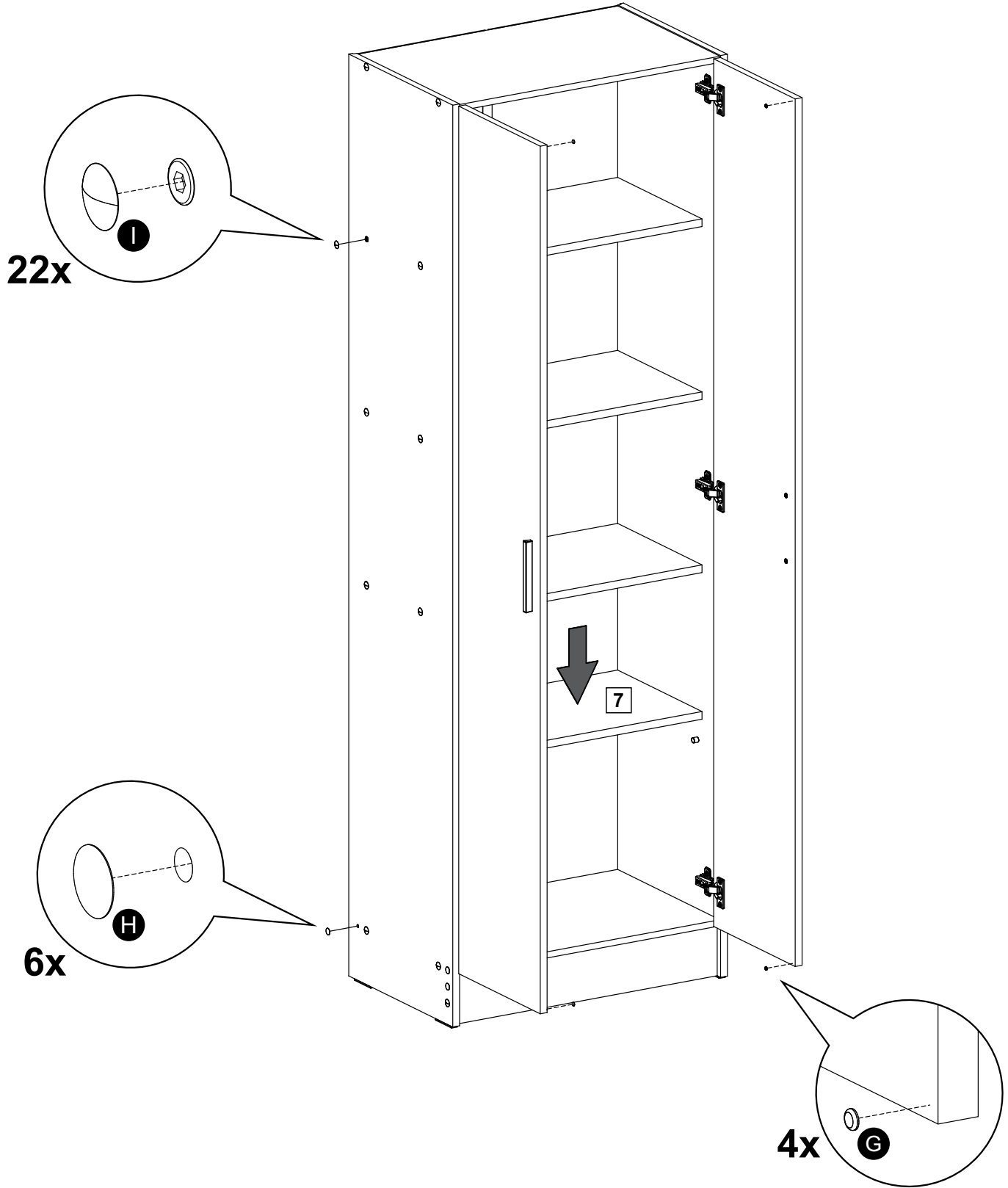
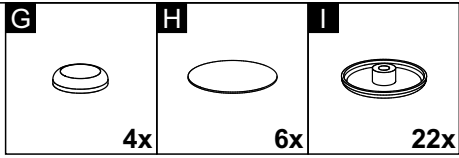

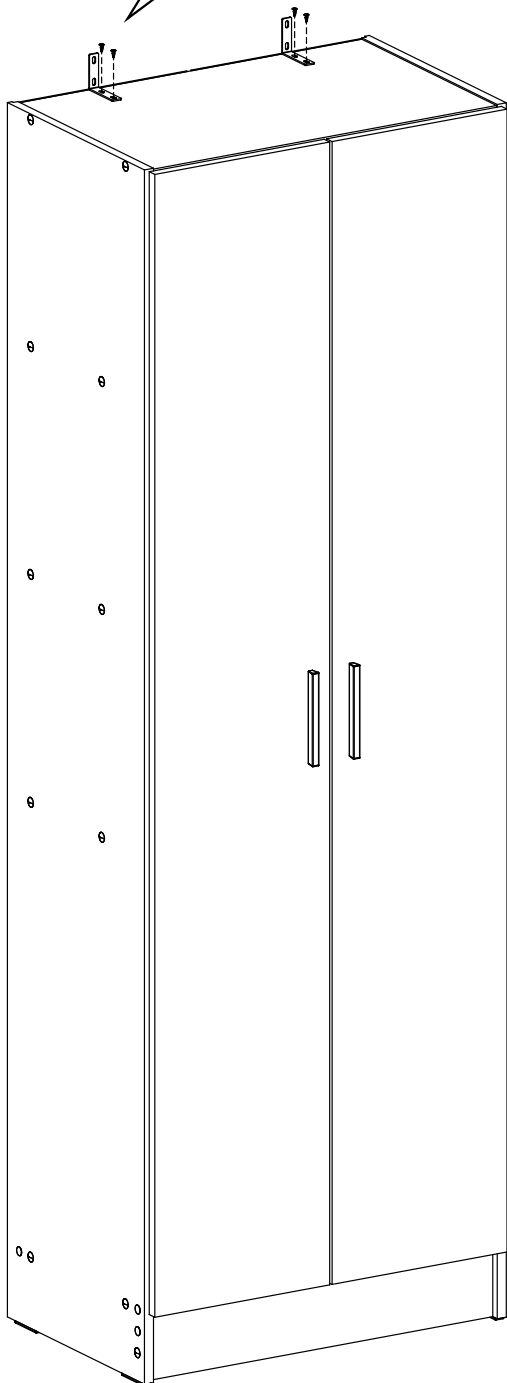
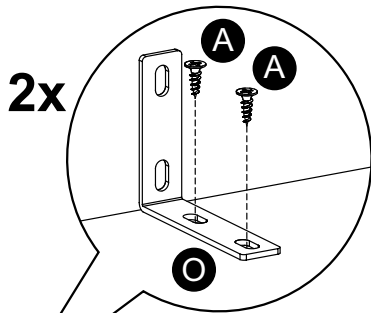
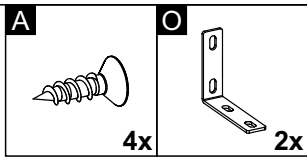

**ATTENTION - AVERTISSEMENT - ACHTUNG
ATENCIÓN - ATENÇÃO - ATTENZIONE**

Falling furniture can cause serious injury or death. To ensure your safety, fix this furniture to the wall using the safety kit provided.

La chute des meubles peut entraîner des blessures graves, ou mortelles. Pour assurer votre sécurité, fixez ce meuble au mur à l'aide du kit de sécurité fourni.

Möbelstürze können schwere oder tödliche Verletzungen verursachen. Um Ihre Sicherheit zu gewährleisten, sichern Sie dieses Möbelstück an der Wand mit dem mitgelieferten Sicherheitsset.

Las caídas de muebles pueden causar lesiones graves o fatales. Para asegurar su seguridad, fije este mueble a la pared utilizando el kit de seguridad proporcionado.

Quedas de móveis podem causar ferimentos graves ou fatais. Para garantir sua segurança, fixe este móvel na parede usando o kit de segurança fornecido.

Le cadute di mobili possono causare gravi o fatali lesioni. Per garantire la tua sicurezza, fissare questo mobile al muro utilizzando il kit di sicurezza fornito.

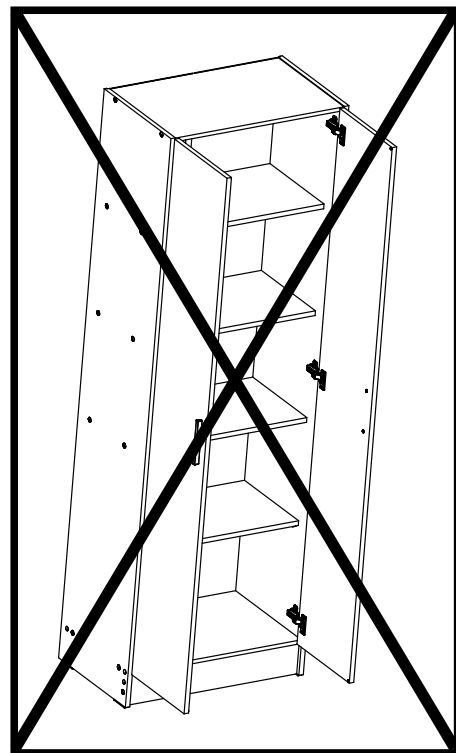

2x

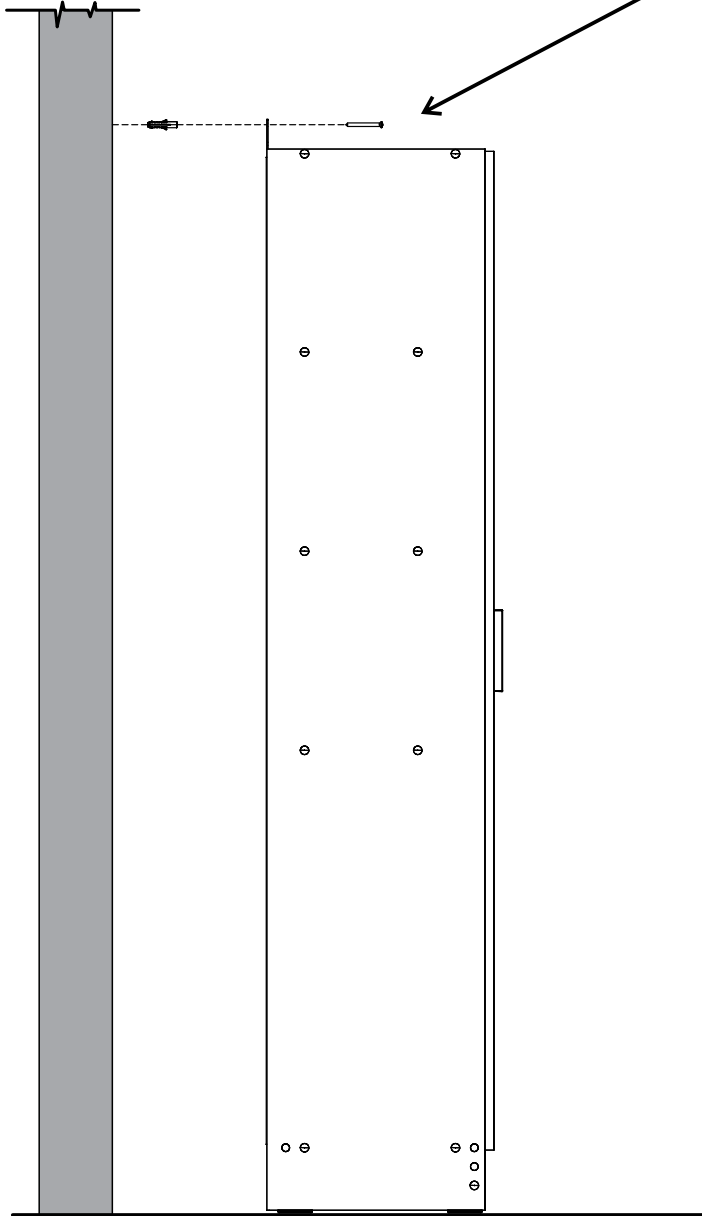
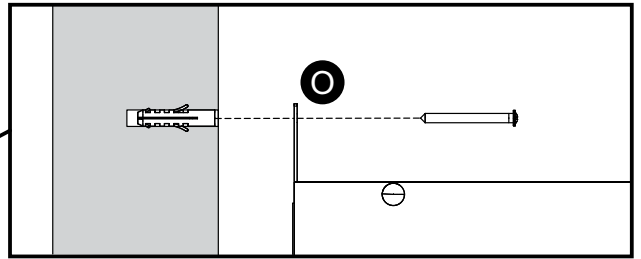

As wall materials vary, the plugs and screws to attach the security kit to the wall are not included and must be purchased separately. If in doubt, seek help from a professional.

Comme les matériaux des murs varient, les chevilles et les vis pour fixer le kit de sécurité au mur ne sont pas incluses et doivent être achetées séparément. En cas de doutes, demandez l'aide d'un professionnel.

Da die Wandmaterialien variieren, sind die Dübel und Schrauben zur Befestigung des Sicherheitssets an der Wand nicht im Lieferumfang enthalten und müssen separat erworben werden. Bei Fragen suchen Sie die Hilfe eines Fachmanns.

Dado que los materiales de las paredes varían, los anclajes y tornillos para fijar el kit de seguridad a la pared no están incluidos y deben adquirirse por separado. Si tiene alguna duda, busque la ayuda de un profesional.

Como os materiais das paredes variam, as buchas e parafusos para fixar o kit de segurança na parede não estão inclusos e precisam ser adquiridos separadamente. Em caso de dúvidas, procure a ajuda de um profissional.

Poiché i materiali delle pareti variano, i tasselli e i bulloni per fissare il kit di sicurezza al muro non sono inclusi e devono essere acquistati separatamente. In caso di dubbi, cerca l'aiuto di un professionista.

Doors Adjustment - Réglage des Portes - Türeinrichtungen - Ajuste de las Puertas - Ajuste das Portas

Vertical Adjustment: Up & Down

Réglage Vertical: Haut et Bas

Vertikale Einstellung: Hoch und Runter

Ajuste Vertical: Arriba y Abajo

Ajuste Vertical: Para Cima e para Baixo

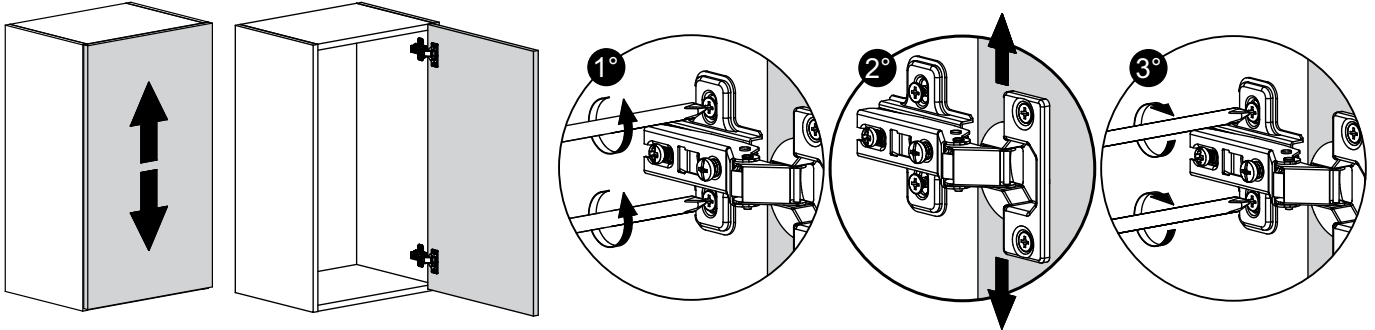

Front Adjustment: In & Out

Réglage Avant: Dedans et Dehors

Vordere Einstellung: Nach Innen und Außen

Ajuste Frontal: Adentro y Afuera

Ajuste Frontal: Para Dentro e para Fora

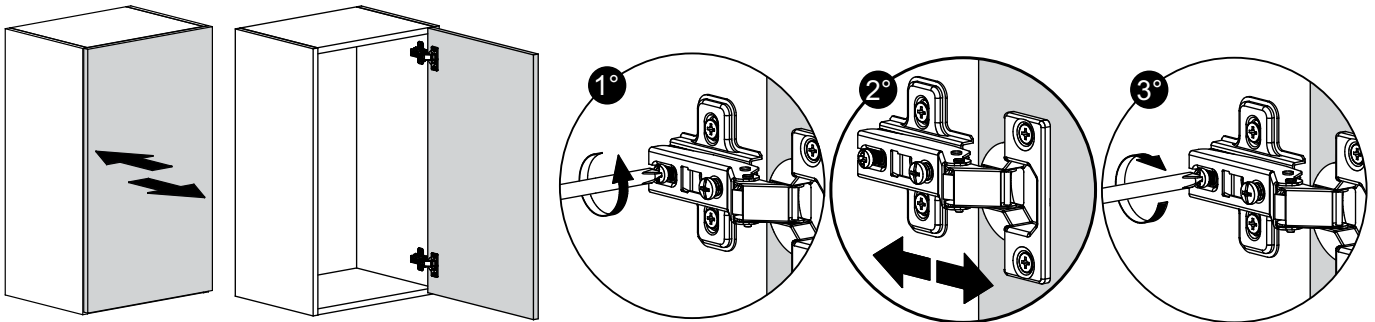

Overlay Adjustment: Side to Side

Réglage du Chevauchement: Cote à Cote

Einstellung der Überlappung: Seite an Seite

Ajuste de Superposición: De Lado a Lado

Ajuste de Sobreposição: Lado a Lado

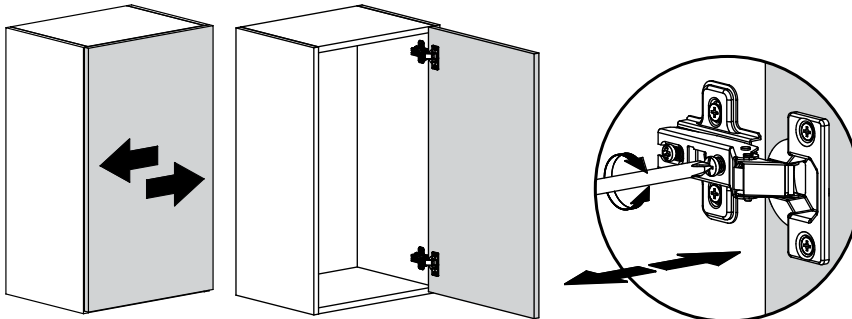

IT	DESCRIPTION / DESCRIÇÃO	THICK ESP	WIDTH LAR	LENGHT COMP	QTY QTD
1	LEFT SIDE PANEL - LATERAL ESQUERDA	15	370	1800	1
2	RIGHT SIDE PANEL - LATERAL DIREITA	15	370	1800	1
3	BACK PANEL - COSTAS	3	289	1698	2
4	DOOR - PORTA	15	290	1694	2
5	BASE - BASE	12	364	570	1
6	TOP PANEL - TAMPO	12	364	570	1
7	SHELF - PRATELEIRA	15	300	570	1
8	FIXED SHELF - PRATELEIRA FIXA	15	300	570	3
9	PLINTH - RODAPÉ	12	100	570	1
A	3,5x12 CC SCREW - PARAFUSO 3,5x12 CC				6
B	3,5x14 CP SCREW - PARAFUSO 3,5x14 CP				24
C	3,5x22 CF SCREW - PARAFUSO 3,5x22 CF				4
D	5x40mm CC10mm FSI SCREW - PARAFUSO 5x40mm CC10mm FSI				22
E	6x30mm DOWEL - CAVILHA 6x30mm				22
F	NAIL - PREGO				58
G	DOOR/DRAWER STOPPER - BATENTE DE SILICONE				4
H	13mm SELF ADHESIVE - TAPA FURO ADESIVO 13mm				6
I	CC10mm PLASTIC CAP - CAPA P/ PAR CC10mm				22
J	8x7mm SHELF SUPORT - SUPORTE PRATELEIRA 8x7mm				4
K	METAL CORNER - CANTONEIRA METÁLICA 18x18x0,75mm				2
L	1674mm H PROFILE - UNIÃO DE COSTAS 1674mm				1
M	FEET - SAPATA DESLIZADORA				4
N	4mm ALLEN KEY - CHAVE ALLEN Z 4mm				1
O	WEDGE - CANTONEIRA COM FURO OBLONGO				2
P	128mm HANDLE - PUXADOR 128mm (NILO – NUBIA)				2
Q1	35mm DOOR HINGE - CALÇO MÉDIO PARA DOBRADIÇA CANECO 35mm				6
Q2	35mm DOOR HINGE - DOBRADIÇA COLO ALTO CANECO 35mm				6