



# Instruction booklet



The type and quantity of components may vary for different style sheds.  
 Assembly of all shed styles is by the same method as detailed.

Before assembling the shed, please check that all parts are present. Report any shortages or other issues immediately.

**DO NOT** attempt to modify the shed or any of it's parts as this may invalidate the warranty.

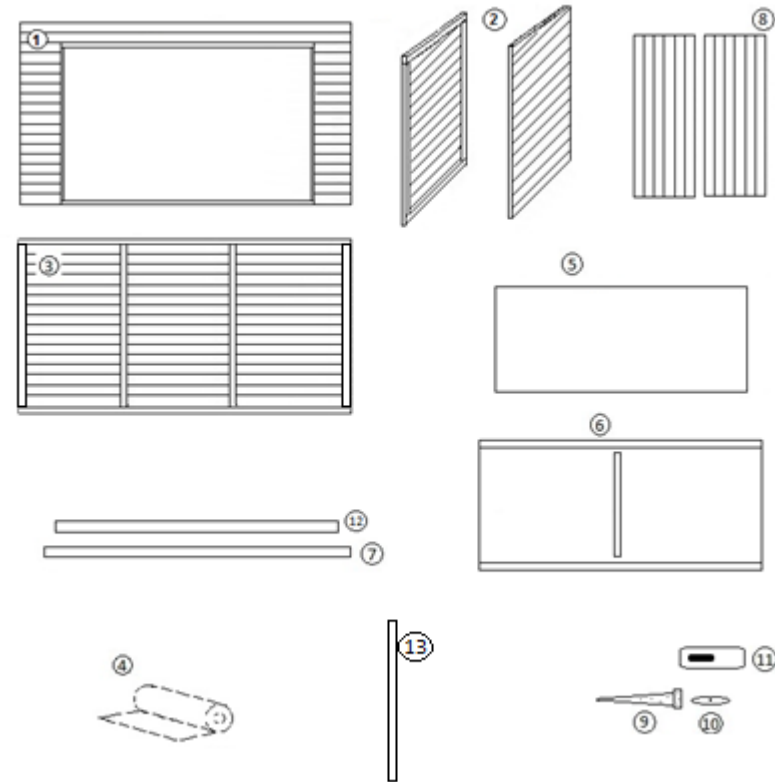

No.	Componets	Number
1	Front panels	1
2	Side panels	1
3	Rear panel	1
4	Felt	1
5	Floor (may be 1 or 2 panels)	1 or 2
6	Roof panel	1
7	Floor bearers tanalised 26mm x 38mm	Variable
8	Door	2
9	Tee Hinges	6
10	Turn button	2
11	Hasp & staple	1
12	Barge boards	Variable
13	Corner cover strips 11mm x 41mm	4
14		
15		
16		
16		

No.	Fixings	
1	60mm screws	
2	40mm screws	
3	25mm black screws	
4	30mm nails	
5	10mm clout nails	
6		

**1. Floor Section**

The floor and floor bearers are supplied separately. The ROOF is supplied with batons attached.

If your floor has more than one floor board please go to section 1b

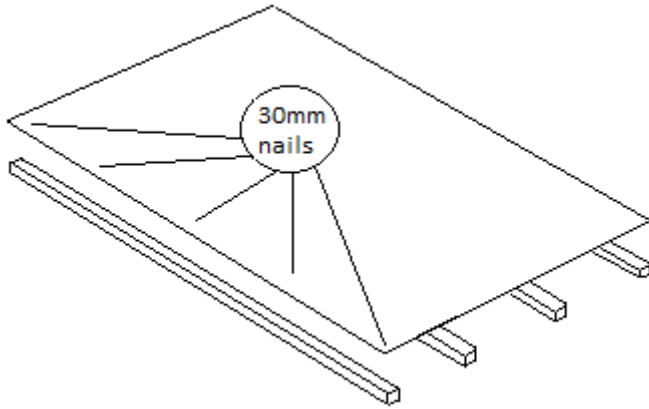

The floor bearers will be either the same length as the width or the depth of the floor.

Place each floor bearer approx. 30cms apart ensuring that one bearer is fixed along both outer edges of the floor.

Fix the floor bearers to the floor using the 30 nails. Lay the floor board on top of bearers and nail through the floor into the bearers.

**1b. Floor section**

If your shed has two or more floor boards, please follow one of the following methods shown in the diagram below.

The floor bearers will be either the same length as the width or the depth of the floor.

Place each floor bearer approx. 30cms apart ensuring that one bearer is fixed along both outer edges of the floor.

Fix the floor bearers to the floor using the 30 nails. Lay the floor board on top of bearers and nail through the floor into the bearers.

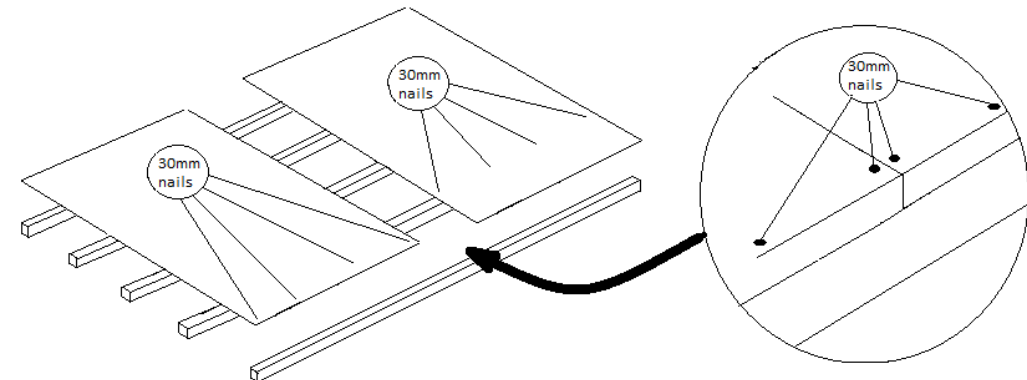
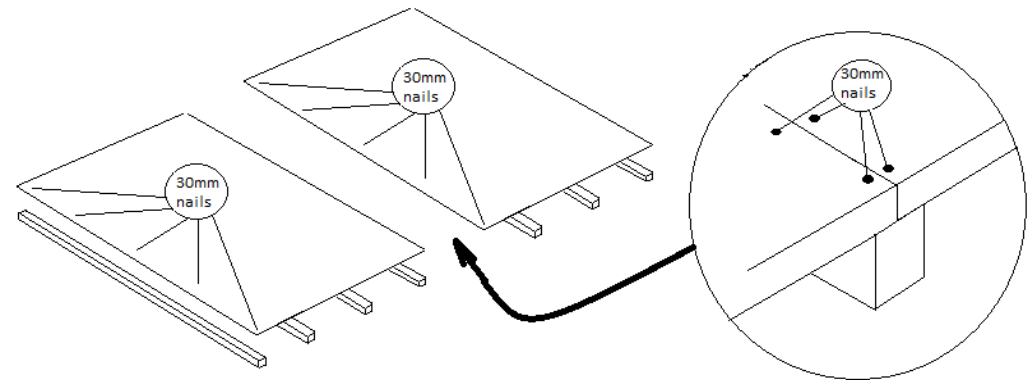

## 2. Wall Panels

### Step 1

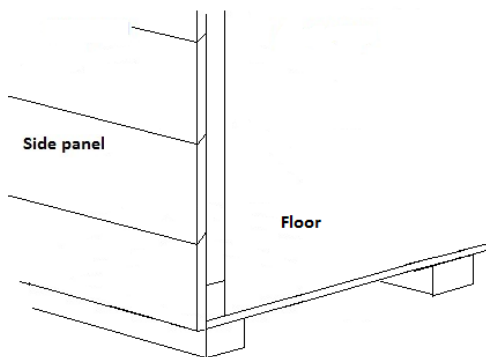

### Step 2

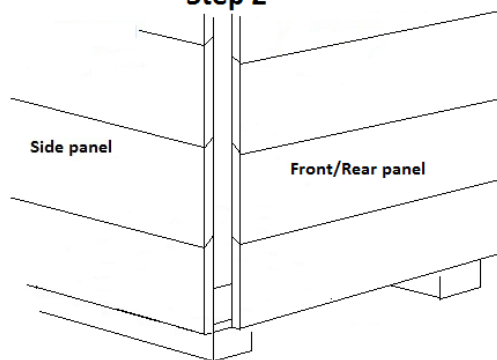

**Step 1.** Position the first side panel so that the edge of the panel is flush with the edge of the floor and the overhang on the bottom of the panel is butted up to the floor.

**Step 2.** Then place the front or rear panel along the edge of the floor and line up the framework of both of the panels to make a corner.

### Step 3.

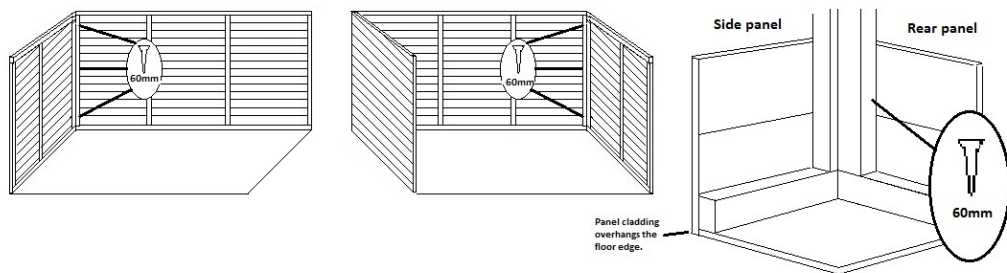

Secure the rear and side panels together as shown below, using 60mm screws. Note that the framework of the panels rests on the floor with the cladding over hanging. Continue until all sides including the front panel are in place and fixed together.

### Step 4.

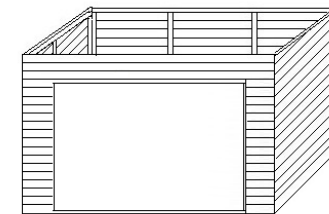
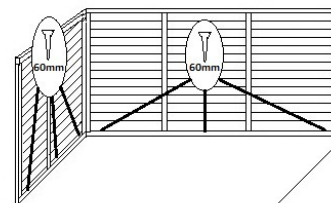

Once all of the side panels are in place, make sure that they are sitting squarely on the floor and fix each side panel to the floor as shown. Use 60mm screws and ensure that the screws go through the floor into the bearers.

All the sides of the shed should be assembled and fixed to the floor.

### Step 5.

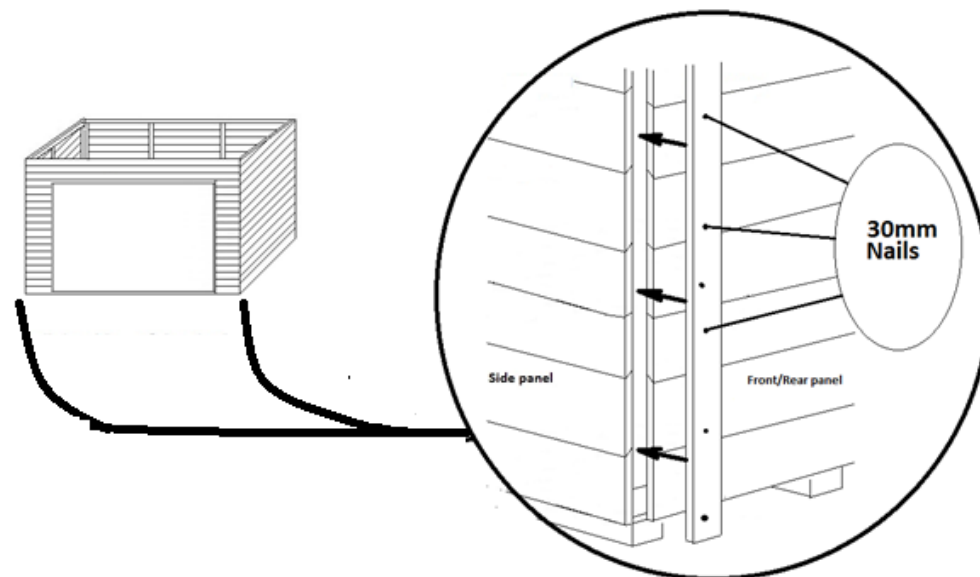

Position the corner cover strips as shown above and fix with 30mm nails.

The roof board(s) have been supplied with the batons attached.

### Step.1

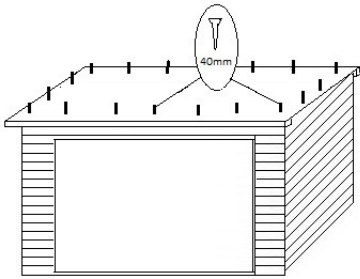

Lay the roof on the shed as shown. Using the 40mm screws, fix the roof into position by screwing through the roof panel into the internal framework of the shed.

### Step.2

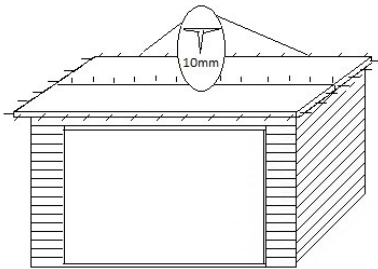

Lay the roof felt with an overhang all round. Fold down the felt at the front and secure using the 10mm clout nails. Tension the felt over the roof and secure to the rear of the roof. Space the clout nail approx. 15cm. Follow the above steps for the sides of the roof. Once the felt is secure trim off any excess.

If the shed has two more lengths of felt, position the first piece along the lower edge of the roof and fix as shown. Then overlap the second piece and fix as shown, ensuring that the felt overhangs on all sides.

### Step.3

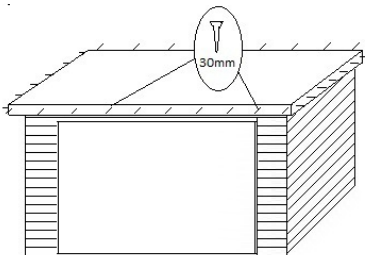

Attach a short barge board to each side of the roof with the 30mm nails, ensuring that the board is flush with the top and front line of the roof.

Attach the front and rear barge boards making sure board is flush with the topline.

Lie the door on a flat surface with the cladding facing upwards. Take one T hinge and position on the door as shown below, making sure that the T hinge is directly above the brace on the underside of the door. Fix the T hinge into place with the 25mm black screws. Repeat for the next T hinge. With the T hinges secured, position the door squarely in the door frame. Fix the top hinge first and the bottom hinge second with the 25mm black screws. Make sure that the door can open and close freely.

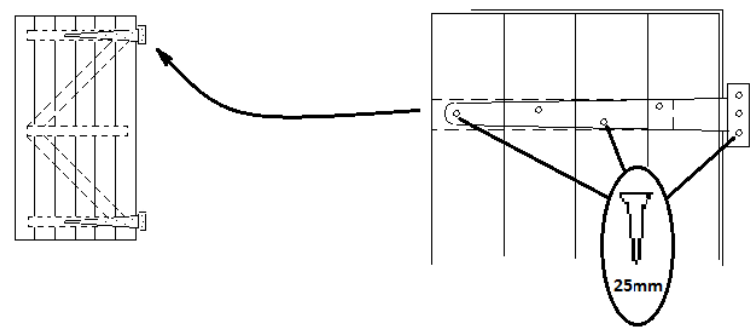

### 5. Hasp & Staple

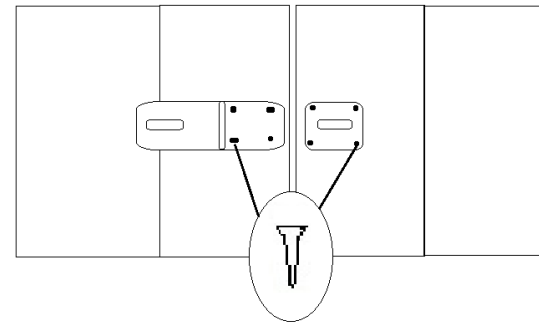

Position the two parts of the hasp & staple across the joint in the doors. Make sure that they are both level and will fit together when fixed into place.

Use the screws provided to fix each part of the hasp & staple to the doors.

### Important Information

Adequate provision must be made to ensure that the building does not come into direct contact with the ground and air is able circulate underneath. A concrete or paving slab base is acceptable, but the building must not be allowed to sit in pooled water during wet conditions. **Timber Information.** Timber is a natural product and can therefore be subject to warping, shrinkage, splitting etc...Periods of excessive dry spells can cause the timber to lose internal moisture resulting in shrinkage on a panel. During periods of excessive wet spells, the timber may experience some swelling. Unfortunately this process cannot be avoided. If you have problems with certain boards shrinking, try to decrease the amount of direct sunlight it gets. During hot spells spray any shrunken boards with a hose pipe, this will replenish the moisture in the timber. If you have any questions or queries during the assembly of your building please contact us:-

**HELP LINE: 01384 897257**

We are constantly improving and updating the quality of our products and as such some components may differ from those shown. We reserve the right to change the specification of our products without prior notice.