

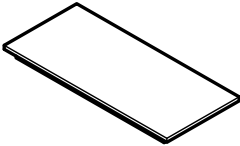

ASSEMBLY INSTRUCTION

Thank you for purchasing the quality product. Be sure to check all packing material carefully for small parts which may have come loose inside the carton during shipment. Separate, identify and count all parts and metal hardware. Compare with all parts list to be sure all parts are present. If any part(s) are missing or damaged, please contact your local furniture dealer. For efficient and speedy service, please indicate the model number and code letter of part(s) needed.





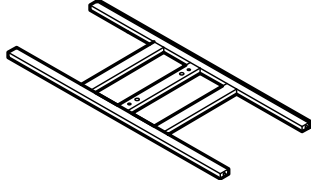
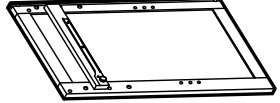
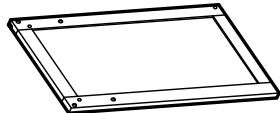
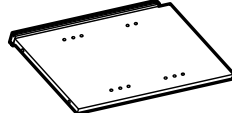
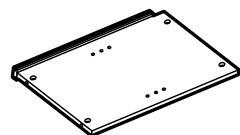
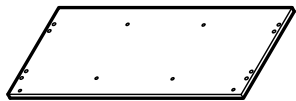
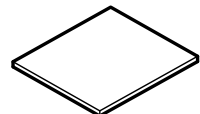

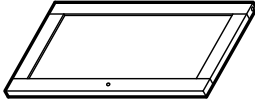
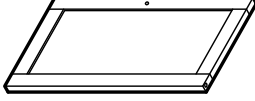



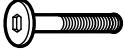

*** Do not fully tighten screws until fully assembled ***





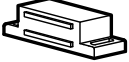

COMPONENT PARTS		
DESCRIPTION	PART NAME	QTY (PCS)
①	TOP 	1
②	DIVISION PANEL 	1
③	CENTER FRAME 	1
④	SIDE FRAME - LEFT 	1
⑤	SIDE FRAME - RIGHT 	1
⑥A	DIVISION CENTER - LEFT 	1
⑥B	DIVISION CENTER - RIGHT 	1
⑦	BOTTOM PANEL 	1
⑧	SIDE SHELF 	2

COMPONENT PARTS		
DESCRIPTION	PART NAME	QTY (PCS)
⑨	CENTER SHELF	2
⑩	BACK PANEL UP	1
⑪	BACK PANEL DOWN	3
⑫	SUPPORT BACK PANEL DOWN	1
⑬A	SIDE RACK - FRONT	1
⑬B	SIDE RACK - BACK	1
⑭	SIDE RACK PANEL	1
⑮	HOLDER	2
⑯	ROD TOWEL	1
⑰	DRAWER HEAD	2
⑱A	DRAWER SIDE PANEL - LEFT	2
⑱B	DRAWER SIDE PANEL - RIGHT	2
⑲	DRAWER BACK PANEL	2
⑳	DRAWER BOTTOM PANEL	2

COMPONENT PARTS		
DESCRIPTION	PART NAME	QTY (PCS)
(21A)	DOOR - LEFT 	1
(21B)	DOOR - RIGHT 	1

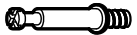
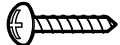
HARDWARE REQUIRED

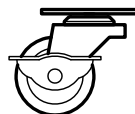
(A)		BOLT	M6 x40mm	10 PCS
(B)		BOLT	M6 x60mm	10 PCS
(C)		SPRING WASHER	1/4"	4 PCS
(D)		FLAT WASHER	M6 x 13mm	4 PCS
(E)		BARREL	M6 x 13mm	10 PCS
(F)		ALLEN KEY	M4	1 PC
(G)		KNOB		4 PCS
(H)		TRUSS HEAD	20mm	4 PCS
(I)		MAGNETIC CATCH		2 PCS
(J)		CHIPBOARD SCREW	M3 x 16mm	4 PCS
(K)		CHIPBOARD SCREW	M4 x 16mm	16 PCS
(L)		SHELF SUPPORT		16 PCS

(M)		DOOR SPRING		4 PCS
(N)		CAMLOCK	9mm	12 PCS
(O)		MINIFIX	24mm	12 PCS
(P)		PAN HEAD SCREW	#8 x 1 1/4"	18 PCS
(Q)		WOODEN PLUG	14.5Ø	8 PCS
(R)		ALUMINIUM PIPE	9Ø x 356mm	3 PCS
(S)		CASTER WITH PLATE (WITH LOCK)	50mm	2 PCS
(T)		CASTER WITH PLATE (WITHOUT LOCK)	50mm	2 PCS

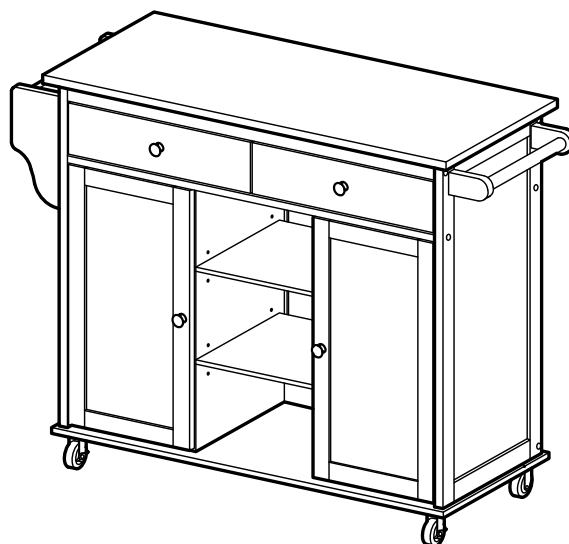

Attention

*** Some number parts listed on the instruction sheet may not to be in parts bag as they already be assembled. Carefully check parts and packing materials prior to ordering replacements.

How to assemble :

STEP 1

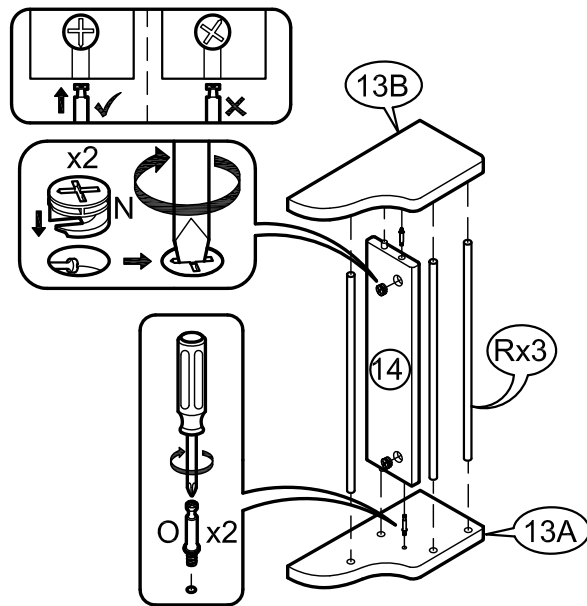

STEP 2

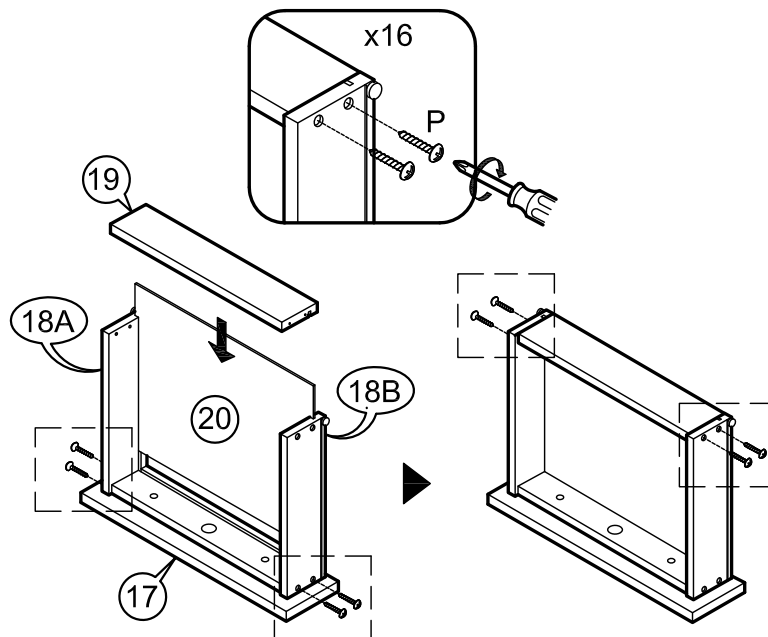

STEP 3

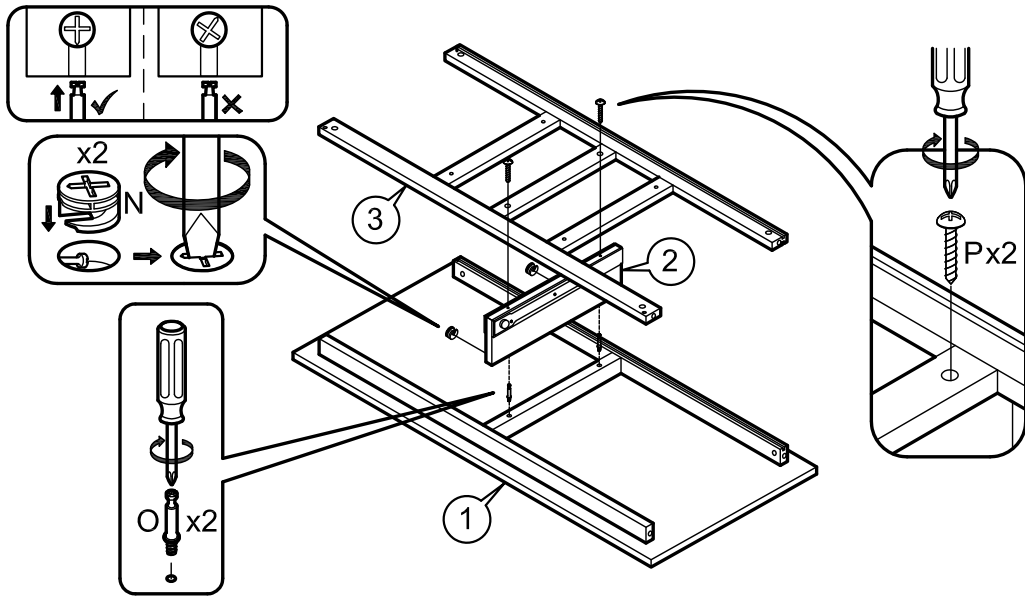

STEP 4

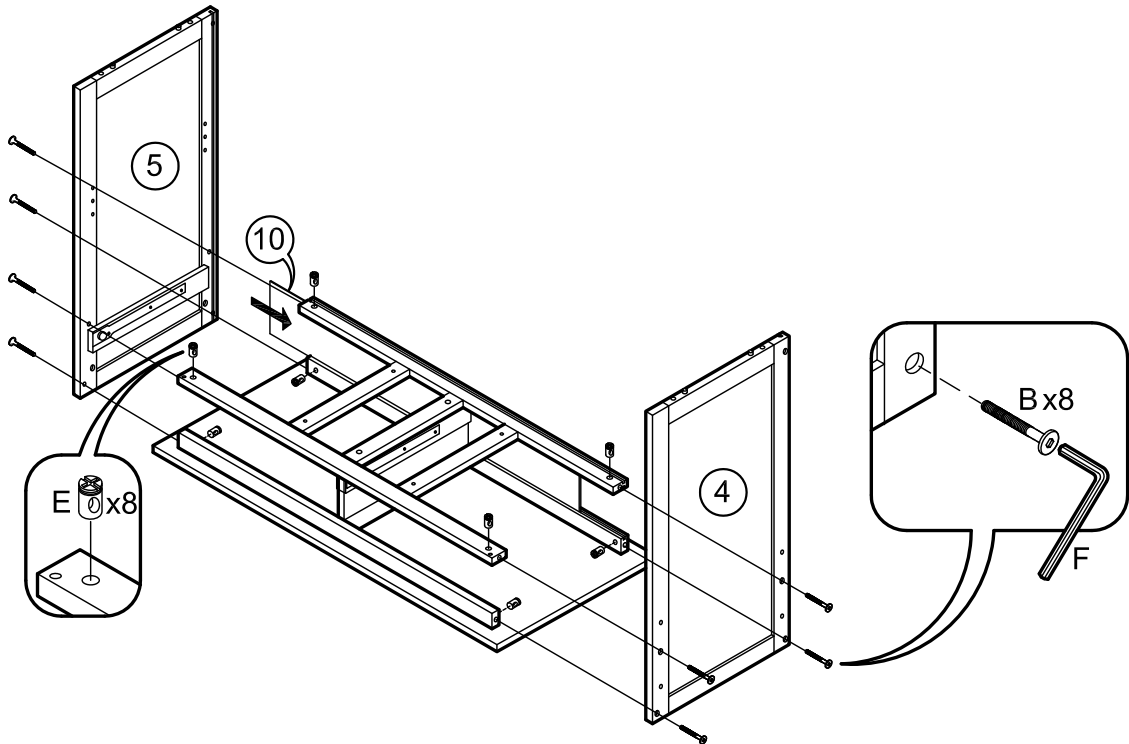

STEP 5

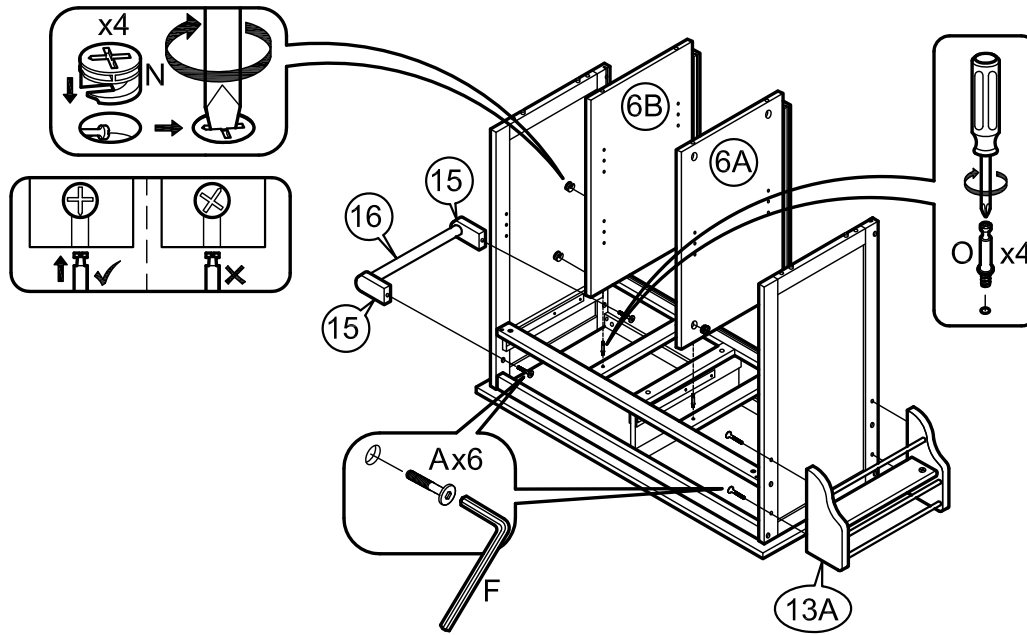

STEP 6

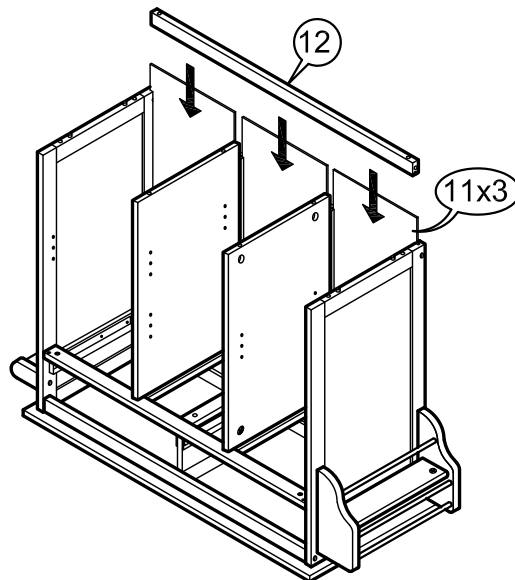

STEP 7

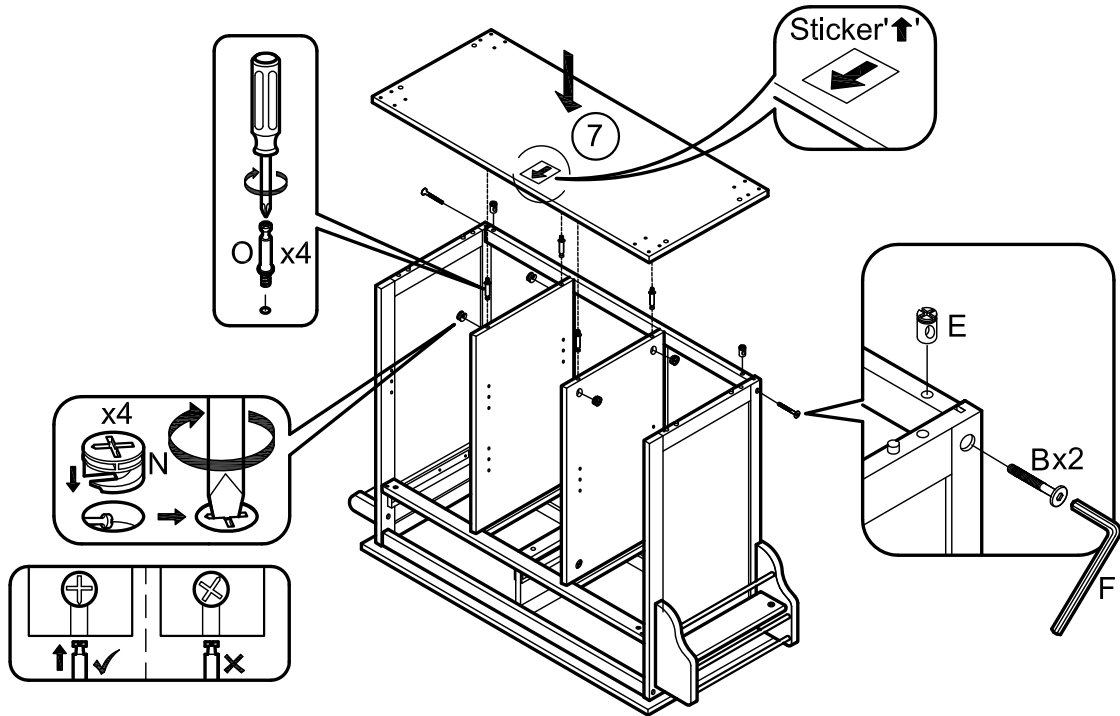

STEP 8

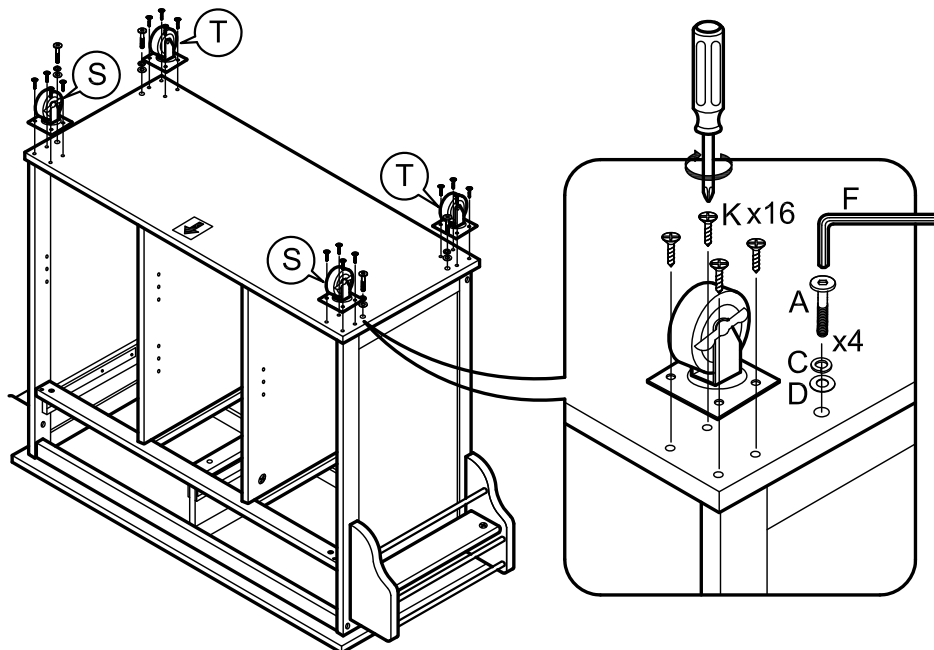

STEP 9

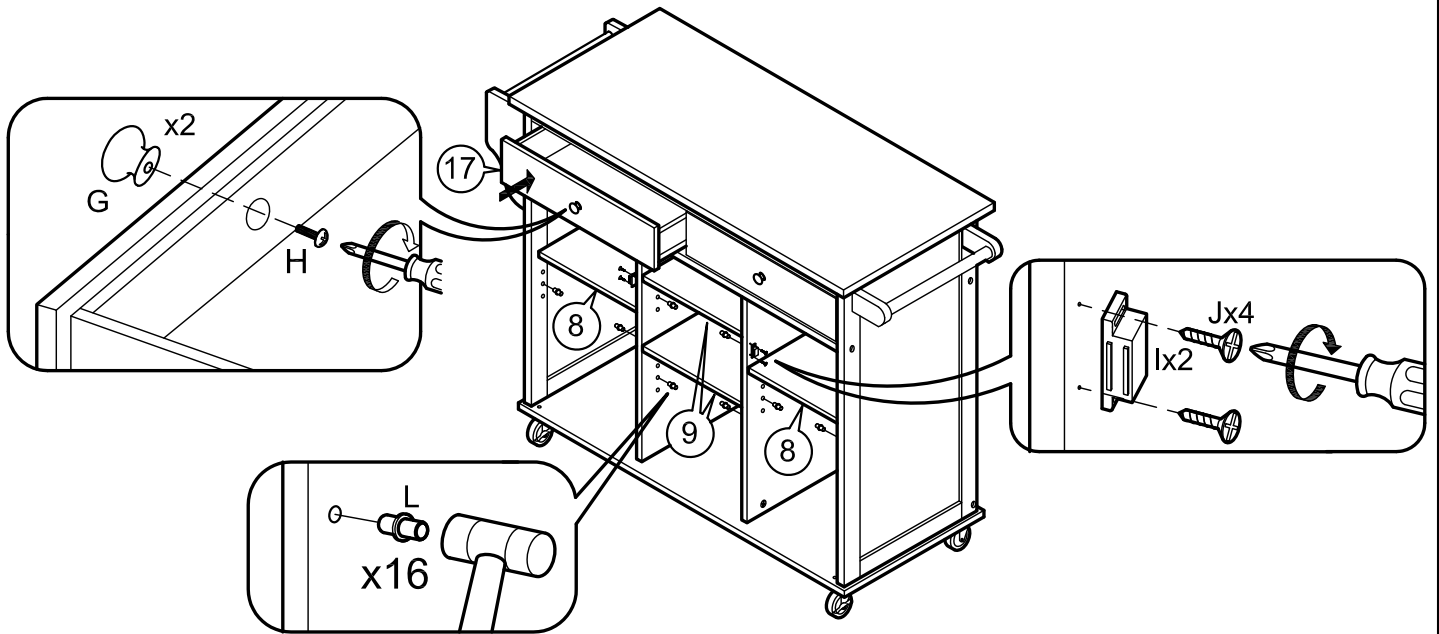

STEP 10

