

# Assembly Instructions

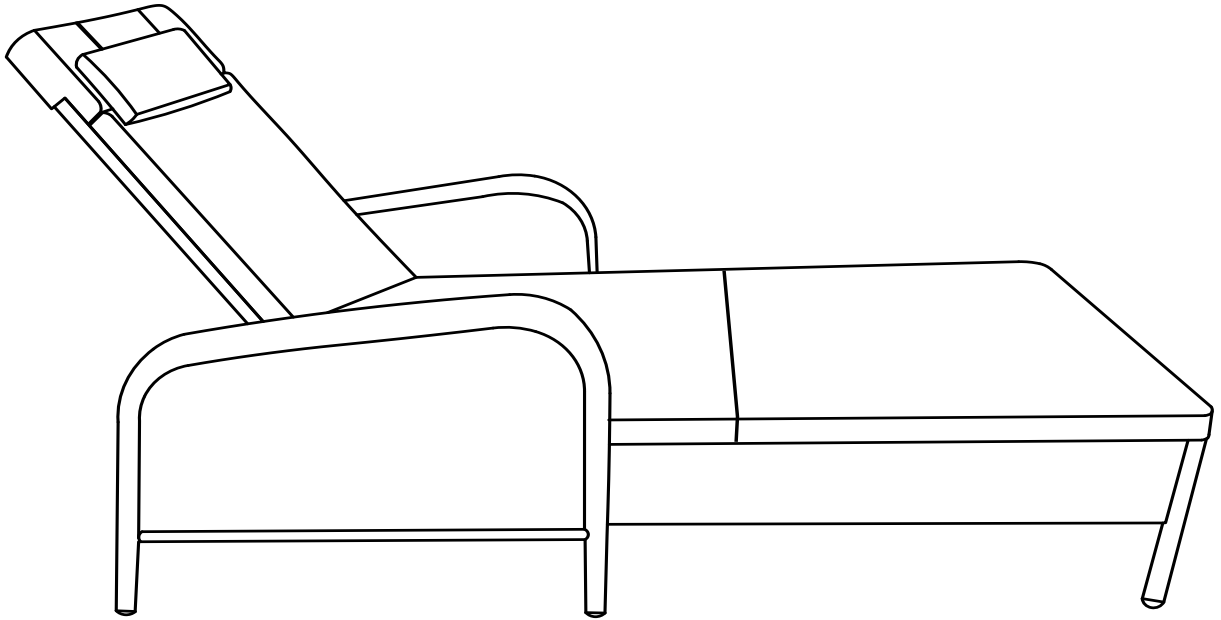

**\*Don't fully tighten all the bolts till the very end!**

## PRE-ASSEMBLY PREPARATION:

- Please read through the instructions before beginning assembly.
- Clear out the space for assembly and lay out all of the parts based on the Parts List, extra room will allow you to easily determine if all the pieces are present.
- Keep small parts and pieces away from children until fully assembled.

Part no.	Part	QTY	Image	Part no.	Part	QTY	Image
A1	Left arm	1		F	Bolt (M6*45mm)	2	
A2	Right arm	1		G	Washer Ø16*Ø6.5*1mm	14	
B	Seat	1		H	Allen wrench	1	
C	Back	1		I	Plastic gasket Ø16*Ø6.5*2mm	2	
D	Front panel	1		J	Cushion	1	
E	Bolt (M6*35mm)	12					

**Step 1:** Attach back C to seat B with 2pcs bolts F, 2pcs washers G and 2pcs plastic gaskets I, using Allen wrench H.

Note: Part I is between part C and part B for protection and against friction.



Bolt F x 2  
M6\*45mm



Washer G x 2



Plastic gasket I x 2

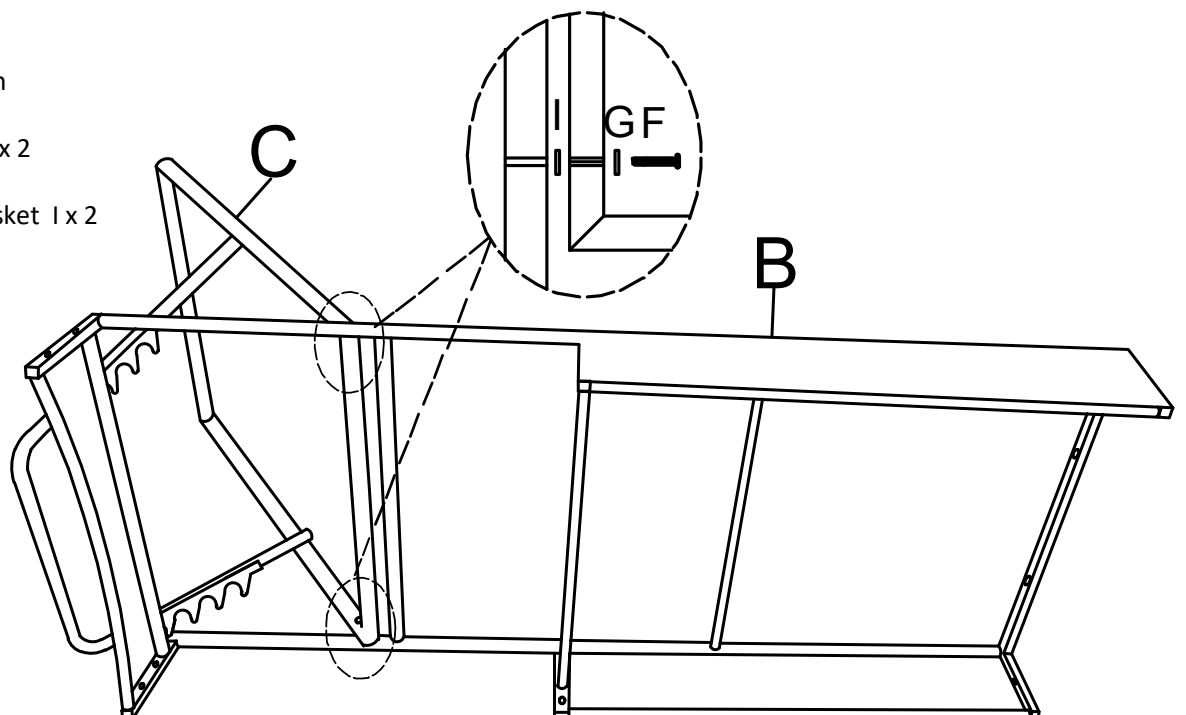

**Step 2:** Attach front panel D to seat B with 4pcs bolts E and 4pcs washers G, using Allen wrench H.

 Bolt E x 4  
M6\*35mm

 Washer G x 4

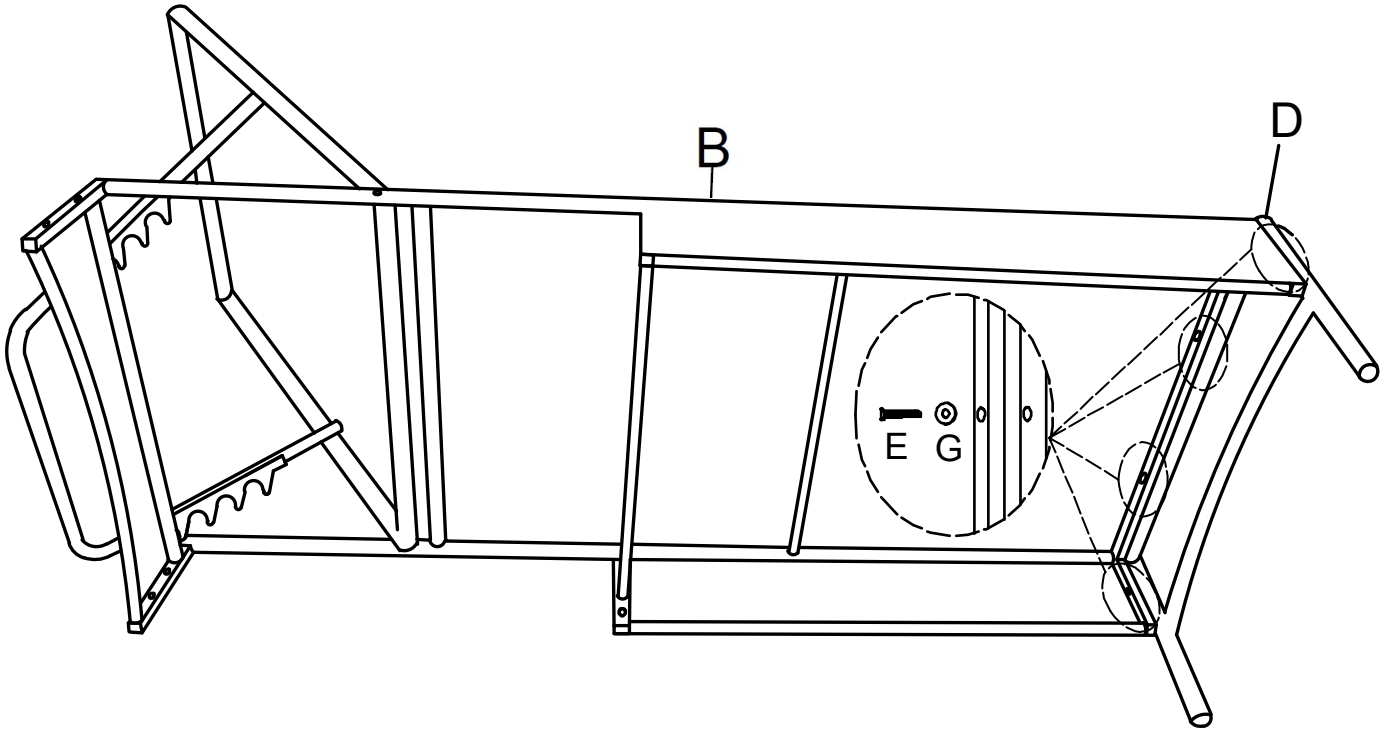

**Step 3:** Attach left arm A1 to seat B with 4pcs bolts E and 4pcs washers G, using Allen wrench H.

 Bolt E x 4  
M6\*35mm

 Washer G x 4

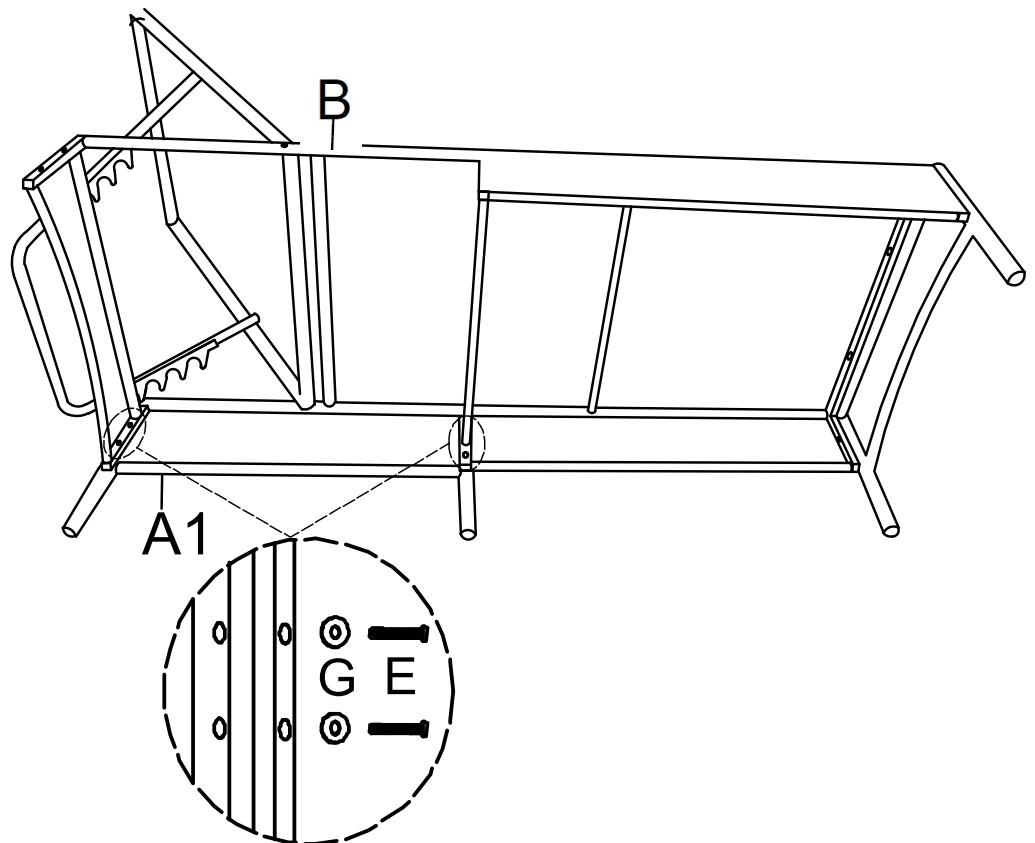

**Step 4:** Attach right arm A2 to seat B with 4pcs bolts E and 4pcs washers G, using Allen wrench H.



Bolt E x 4  
M6\*35mm



Washer G x 4

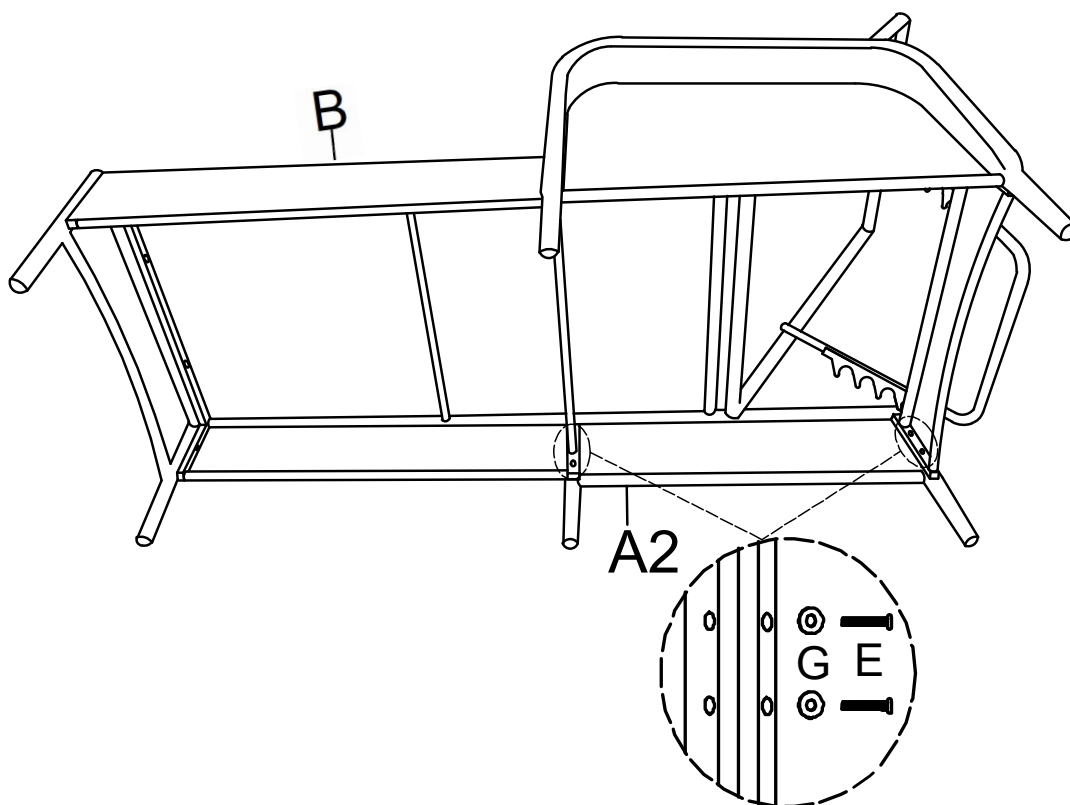

**Step 5:** Put cushion J onto the seat. Assembly is now complete and the product is ready for use.

