

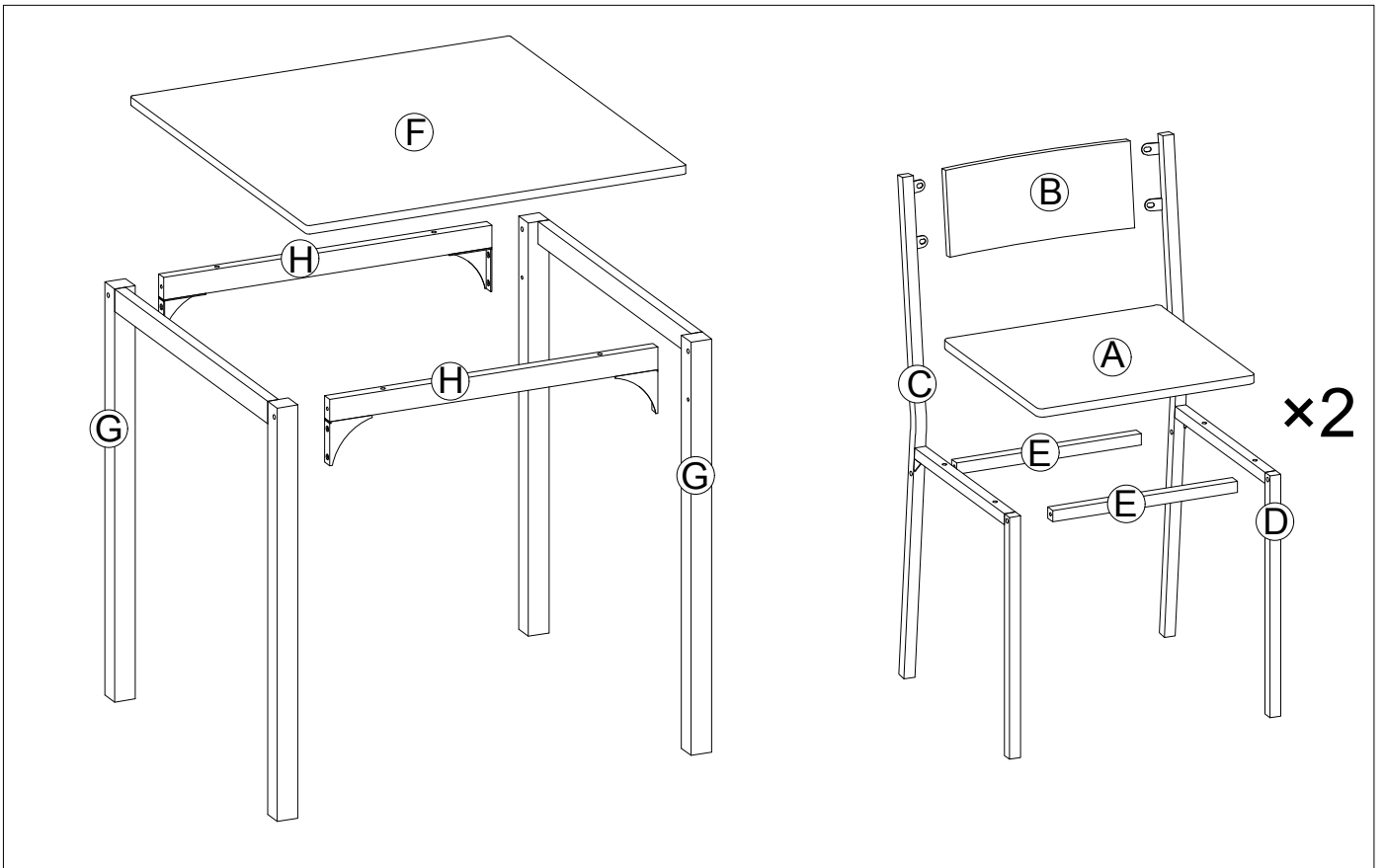

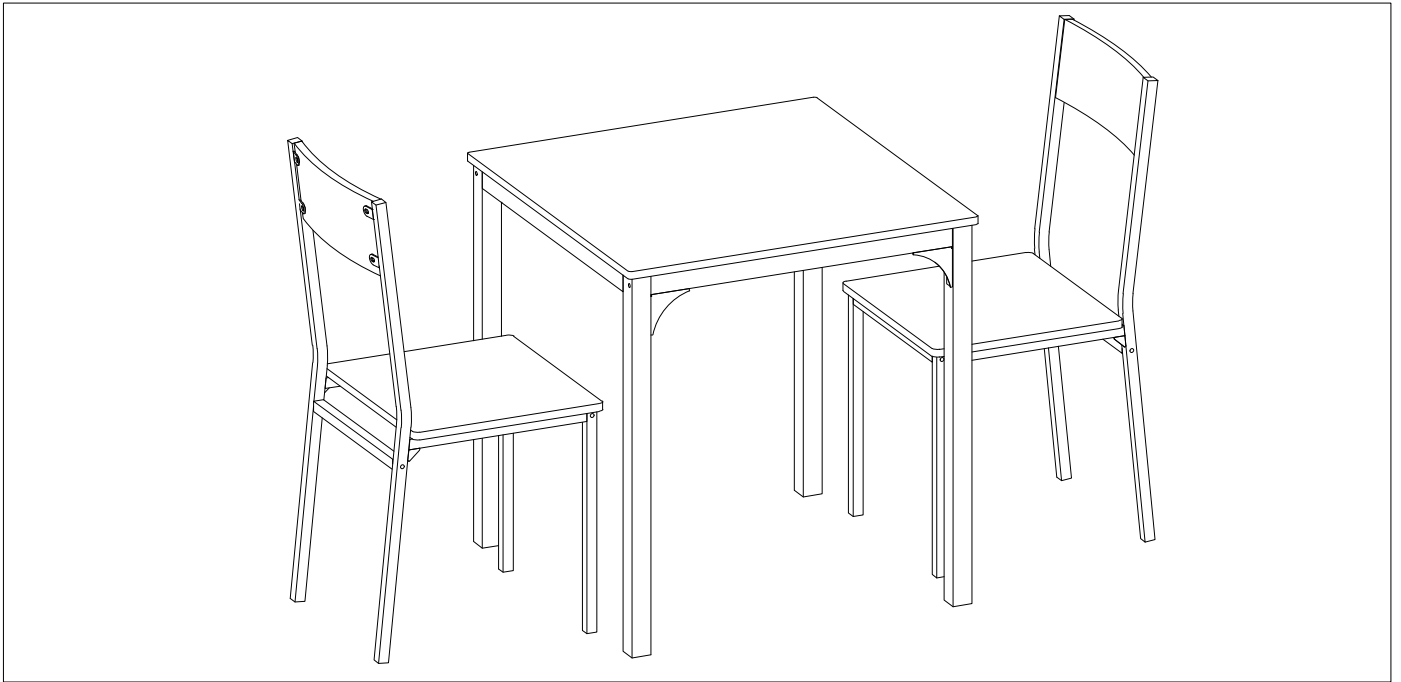









ASSEMBLY INSTRUCTIONS

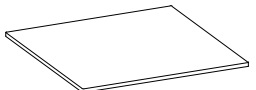
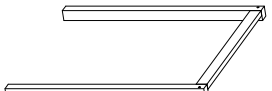
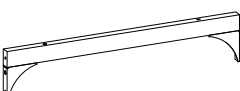

part list

	
A×2PCS	B×2PCS
	
C×2PCS	D×2PCS
	
E×4PCS	F×1PC
	
G×2PCS	H×2PCS

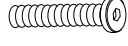
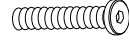
hardware list

 M6×12mm ①×12PCS	 M6×30mm ②×8PCS
 M6×40mm ③×8PCS	 M6×50mm ④×4PCS
 M6×55mm ⑤×4PCS	 M4 ⑥×1PC

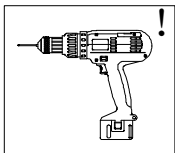

PLEASE BE CAREFUL DO NOT DAMAGE THE HOLE POSITION WHEN YOU USE POWER TOOLS !

Step 1

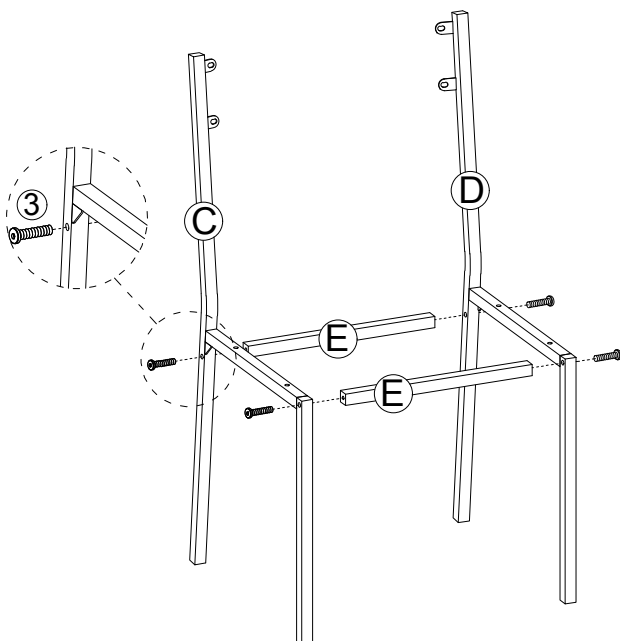

M6×40mm
③×8PCS



×2

Step 2

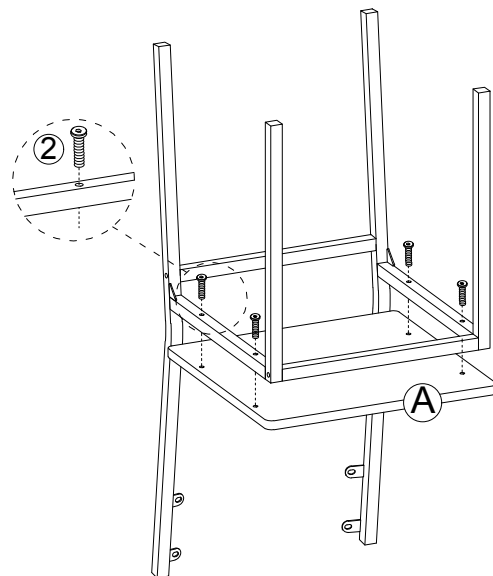

M6×30mm
②×8PCS



×2

Step 3

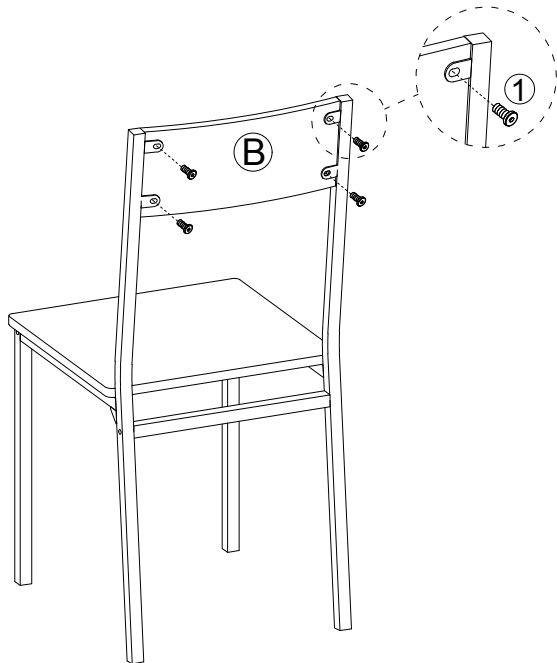

M6×12mm
①×8PCS



×2

Step 4

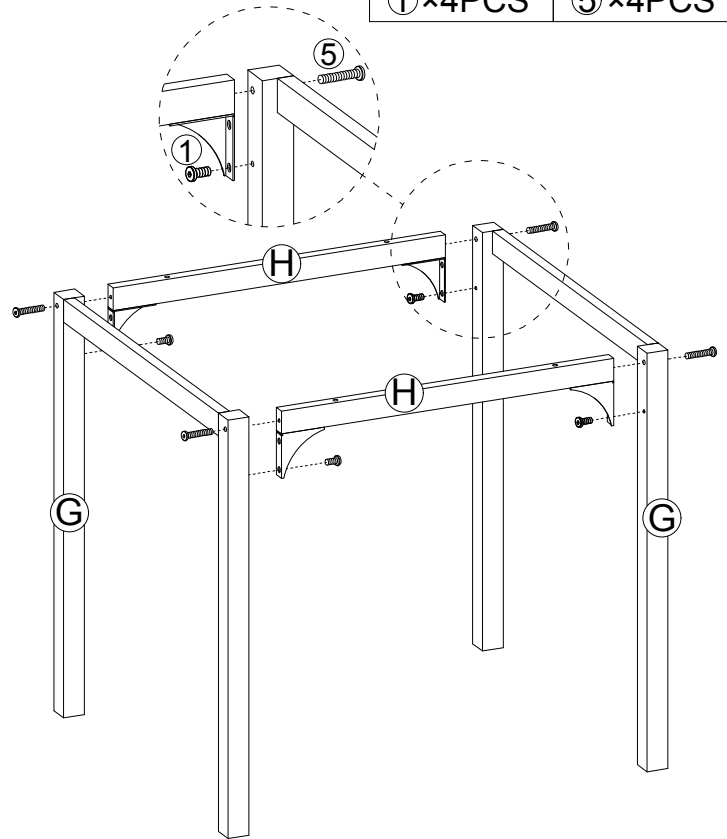

M6×12mm
①×4PCS

M6×55mm
⑤×4PCS

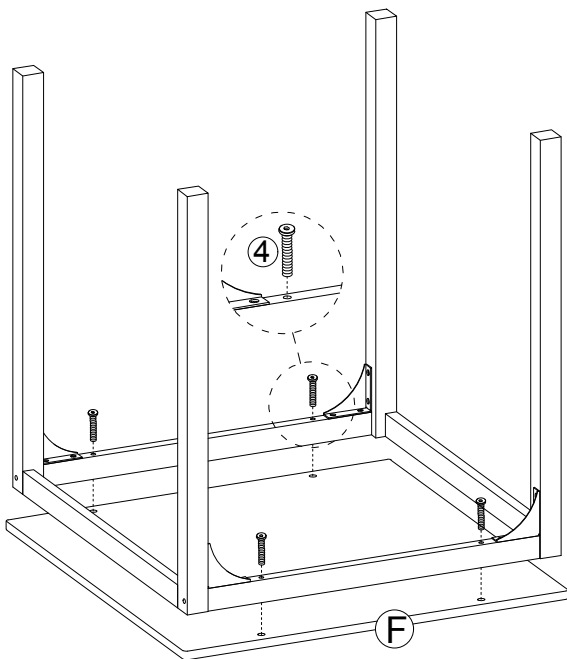

Step 5

M6×50mm
④×4PCS



Step 6

