

**Platform Bed**  
**Assembly Instruction**  
Contains One Bed and Hardware

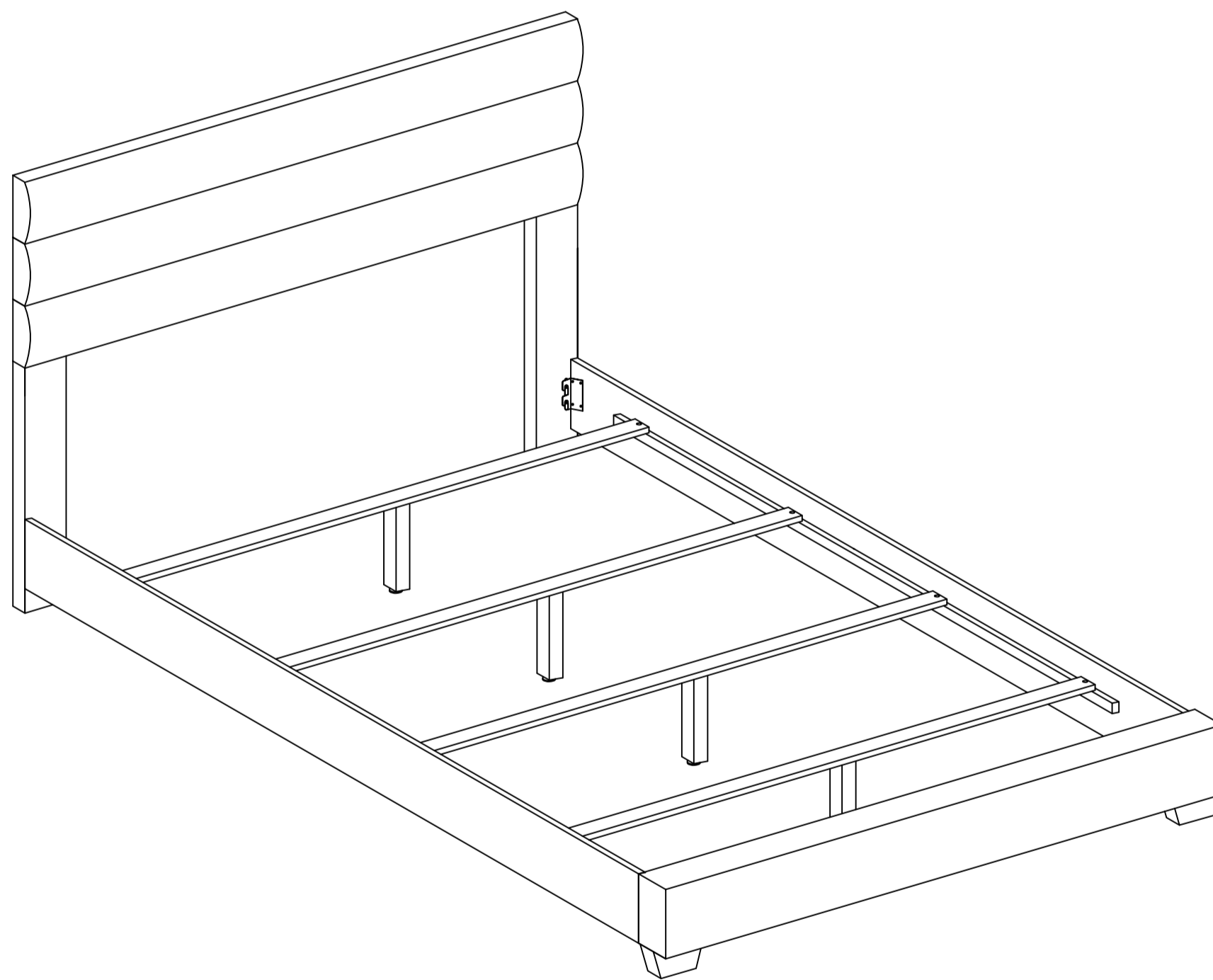

**IMPORTANT NOTE:**

Carefully remove all the parts from the box. Arrange on a flat surface and verify you have all of the following parts and hardware

**TOOLS REQUIRED:**  
Phillips Screwdriver

# PARTS LIST

**A. Headboard (3 pcs)**

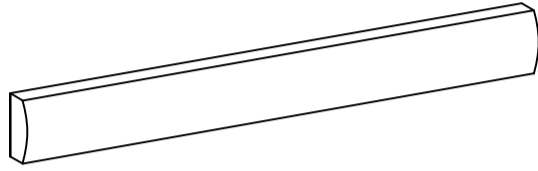

**B. Footboard (1 pc)**

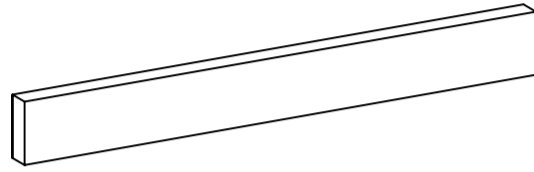

**C. Side Rail (2 pcs)**

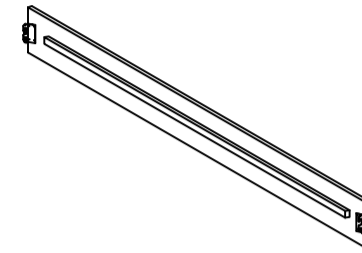

**D. Headboard Legs (2 pcs)**

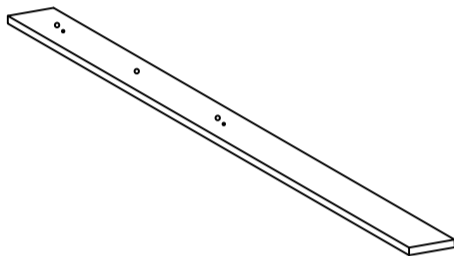

**E. Footboard Legs (2 pcs)**

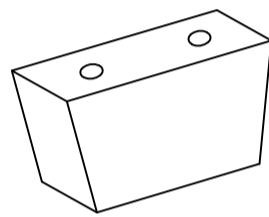

**F. Headboard Support Wood (1 pc)**

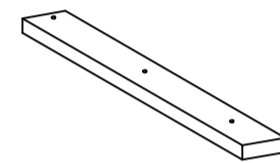

**G. Wood Slat (4 pcs)**

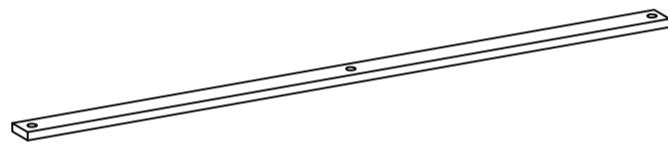

**H. Center Leg (4 pcs)**

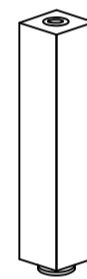

# HARDWARE LIST

**I. 20mm Bolt (8 pcs)**

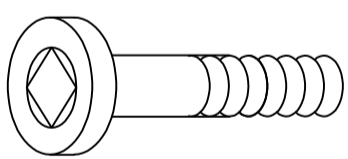

**J. 40mm Bolt (13 pcs)**

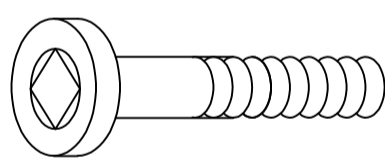

**K. Large Hex Key (1 pc)**

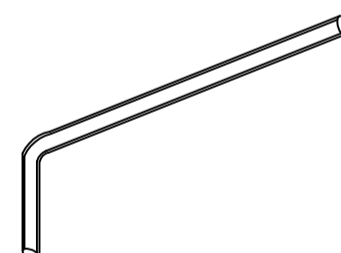

**L. Small Hex Key (1 pc)**

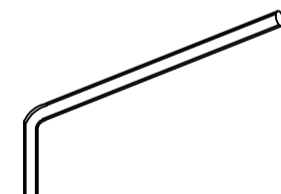

**M. Spring Washer (9 pcs)**



**N. Flat Washer (9 pcs)**

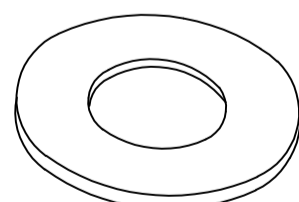

**O. 32mm Screw (12 pcs)**

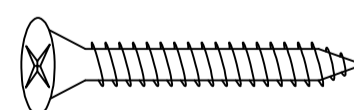

**P. 50mm Screw (4 pcs)**

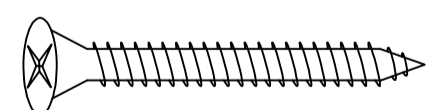

**Q. Adjuster (4 pcs)**

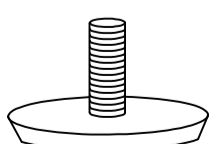

# ASSEMBLY INSTRUCTIONS

## STEP 1

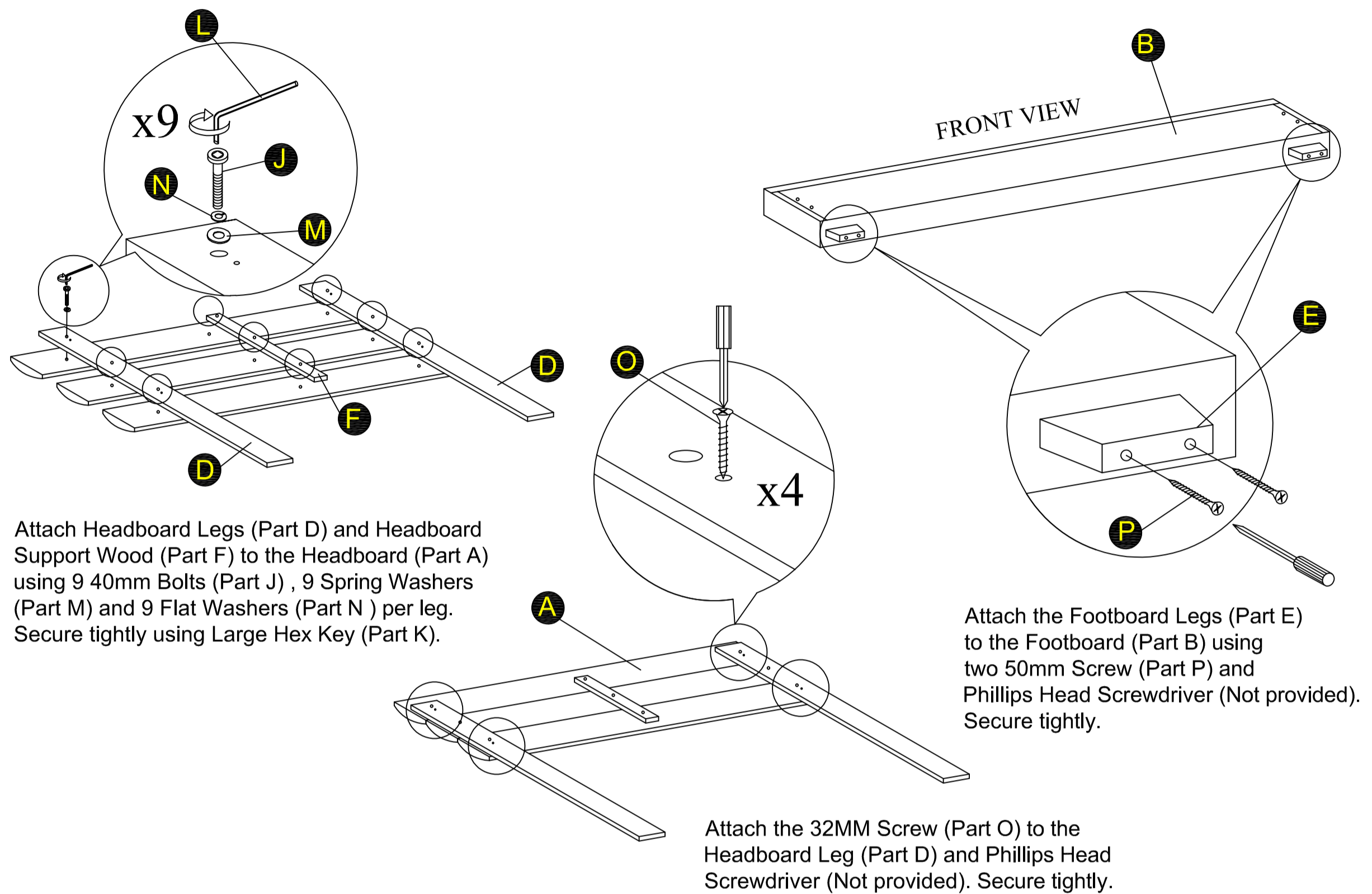

## STEP 2

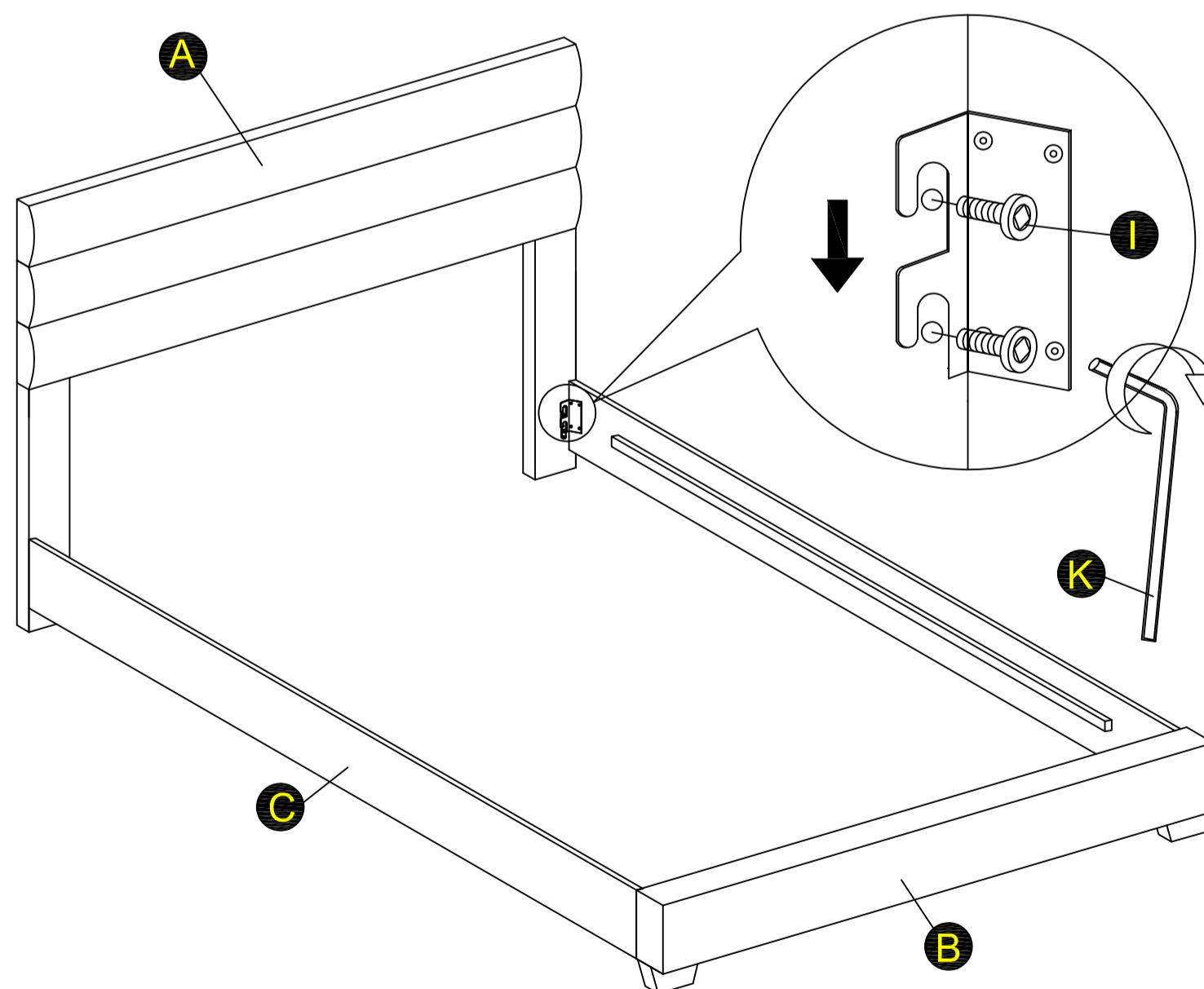

# ASSEMBLY INSTRUCTIONS

## STEP 3

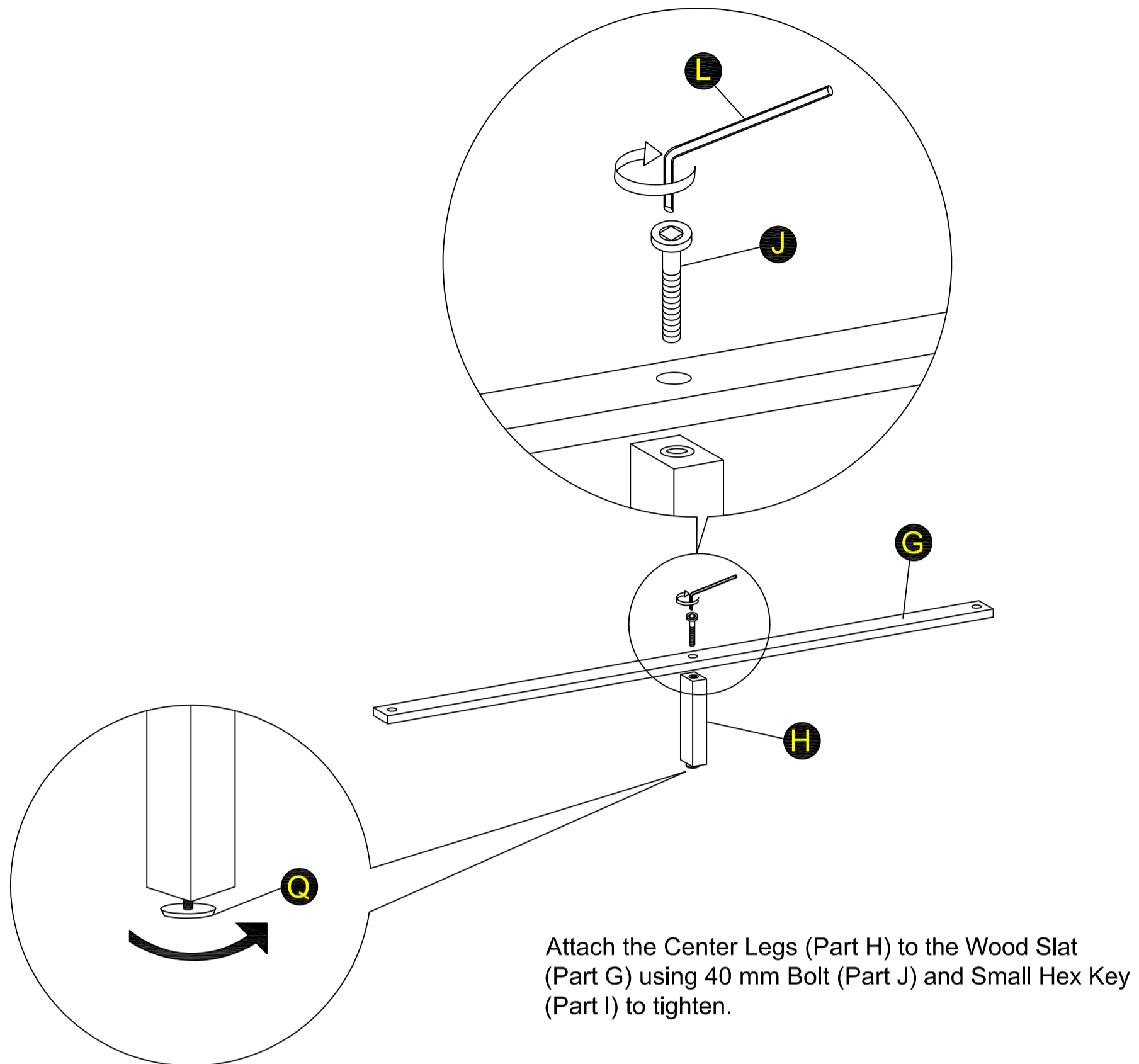

## STEP 4

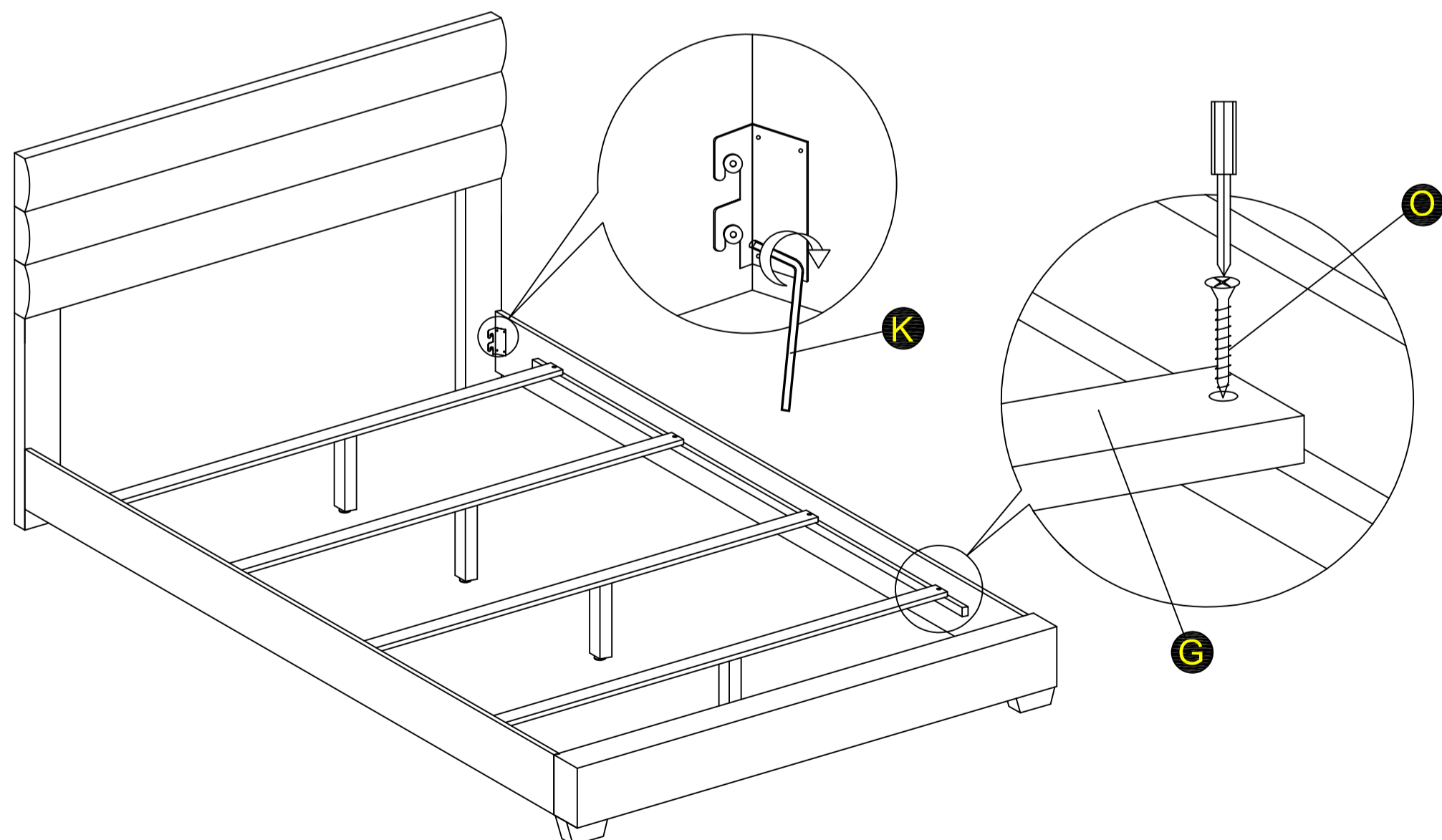

Place the Wood Slat (Part G) into the bed as shown. Secure the Wood Slat to the Side Rails (Part C) using 8 Screws 32mm (Part Q) and a Phillips Head Screwdriver (Not provided). Your bed is now set up and ready for use.