







ASSEMBLY PART						
A	DENSITY BOARD		5	D	LONG LINK PIECE	 10
B	END CAP		16	E	THE UPRIGHT CONNECTING PIECE	 8
C	SHORT LINK PIECE		10	F	BOTTOM SUPPORT PIECE	 5

1. Install upright connecting piece E and long and short link piece C/D. Installed in place as shown in the picture, it can prevent the product from shaking.



2. Install bottom support piece F (the number of supports is subject to the actual situation) and board A as shown in the figure, support at the insertion holes on both sides, positioning function, non stress area.

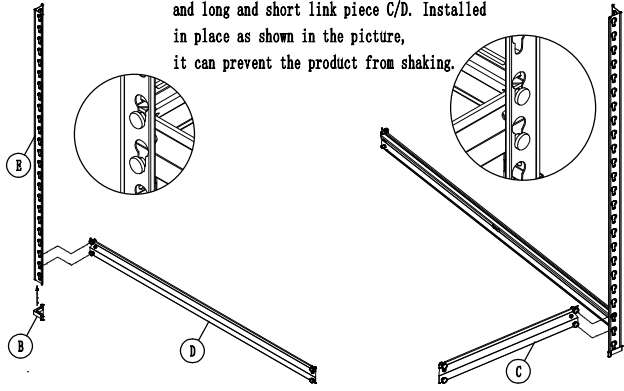
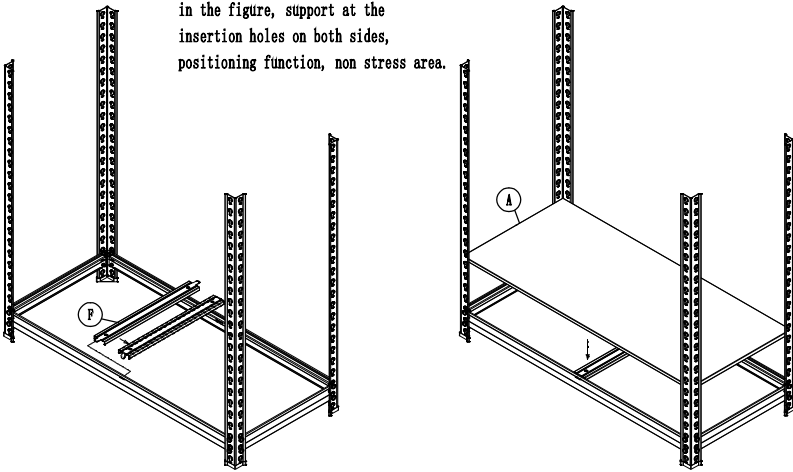

3. Use long and short link piece C/D to connect two upright connecting piece E as shown in the picture.

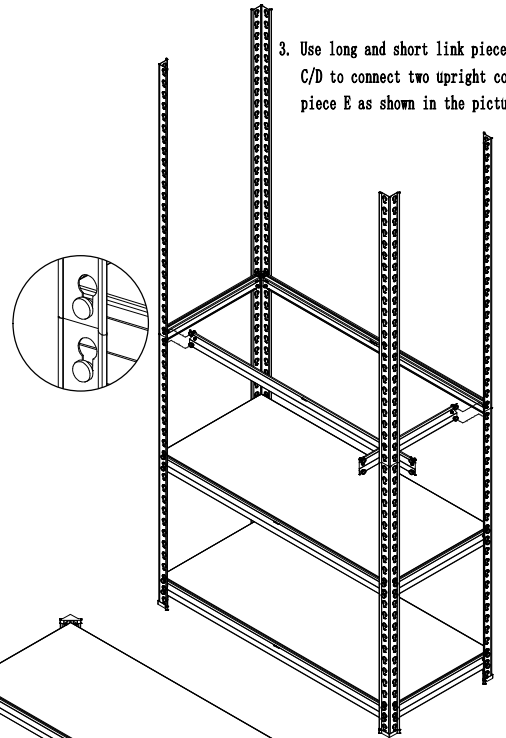

4. As shown in the figure, multiple combination installation methods can be selected.

