

Storage Shed 6x8FT

ASSEMBLY INSTRUCTIONS



Product Maximum Overall Dimensions:1710mm*2400mm*2040mm

Please read all instructions carefully before assembly. It is best to familiarize yourself with the parts and collate the appropriate parts for each step.

If you encounter any problems during the assembly process, contact us anytime!



support@sylviera.com



2137969388



Before You Start Assembly

Please check your local building codes for foundation, placement, and other requirements before starting construction.

Read and understand the important information and helpful tips in this Owner's Manual — they will make your assembly process easier and more enjoyable.

Assembly Instructions:

Before you begin, read all instructions and related information carefully, and be sure to follow the steps in order to achieve a successful result.

Floor Foundation:

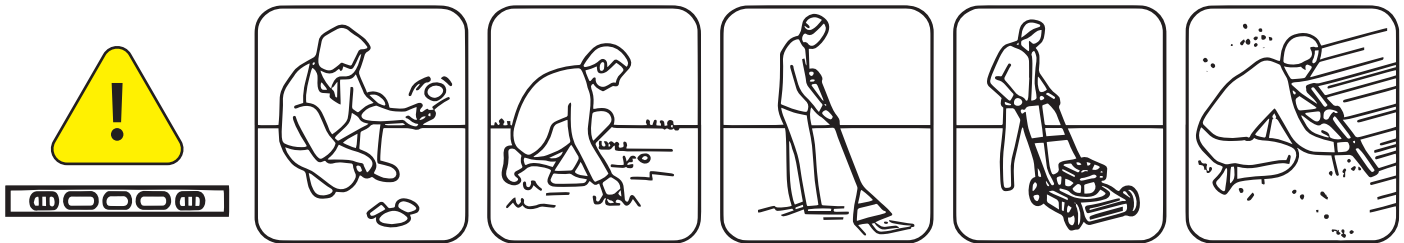

The ground must be leveled so that the base of the product is even on all sides. Use a level to check for accuracy.

The foundation can be made of treated wood or concrete to prevent moisture from entering the product. The product is not designed to be placed directly on grass, as the ground can become muddy when it rains.

If you are making a concrete slab, it's important that it slopes slightly toward the edges to prevent water from seeping inside. Allow sufficient time for the concrete or cement to dry before assembling the upper components.

The base can also be built with bricks, blocks, or mounted on a concrete slab.

Bricks or blocks should be securely fixed to a level concrete foundation, and the product frame should be screwed firmly to the base.

Recommendation: Build a wooden or concrete base as the foundation.

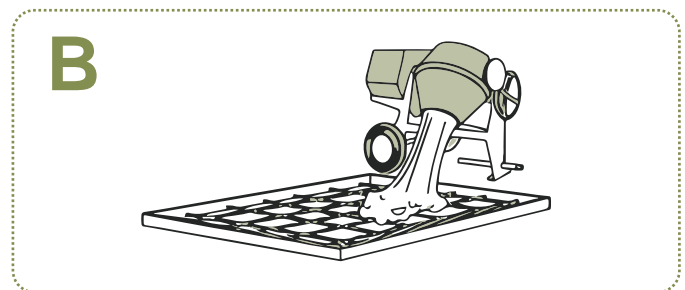
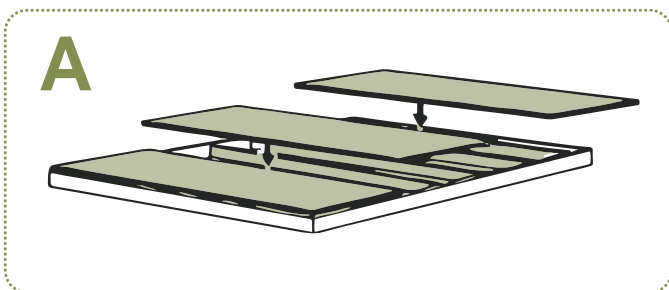

1. Parts and Components Checklist:

Product Setup: What You Need

Before you begin, separate and identify all parts and hardware to make sure you have everything needed for assembly (see the Parts List page).

Do not attempt to assemble the structure if any parts are missing, as a product that is not fully assembled may be damaged by external forces.



Power drill



Phillips Screwdriver



Gloves



Plastic Squeegee



Tape Measure



Ladder



Knife



#1 W1 x18



#2 W2 x2



#3 W3 x2

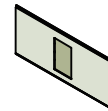

#4 W4 x2

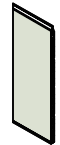

#5 W5 x8



#6 W6 x1

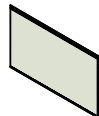

#7 W7 x16

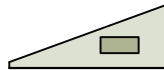

#8 W8 x1

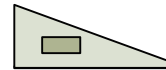

#9 W9 x1

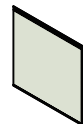

#10 W10 x5



#11 W11 x2



#12 W12 x1

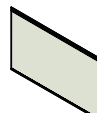

#13 W13 x2



#14 JW1 x3



#15 JW3 x1

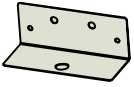

#16 J1 x9



#17 J4 x1



#18 J5 x4



#19 J6 x3

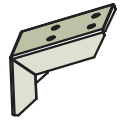

#20 J7 x2



#21 J8 x2



#22 J9 x4



#23 J11 x2



#24 J13 x1

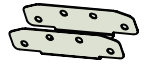

#25 J14 x1



#26 J15 x4



#27 SA x4

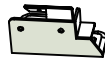

#28 SDL x1

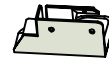

#29 SDR x1

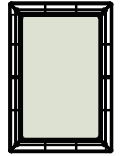

#30 GC x2

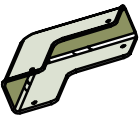

#31 SB x4

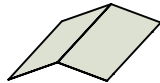

#32 PC2 x2

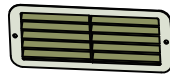

#33 GF x3



#34 CX x2

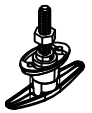

#35 MS2 x1

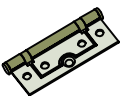

#36 JL1 x4



#37 T1 x256



#38 T3 x90



#39 T5 x42

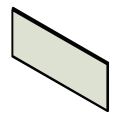

#40 W14 x2



#41 A1 x2



#42 A2 x2



#43 A3 x4



#44 A4 x4

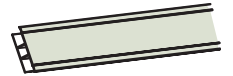

#45 H1 x1



#46 G1 x4



#47 G2 x4



#48 J16 x1



#49 J17 x1



#50 CXP x1



#51 GJ x2

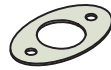

#52 MSP x1

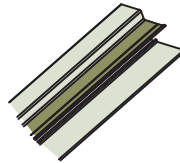

#53 L1 x1



#54 L2 x1



#55 L3 x1



#56 L4 x1



#57 T6 x16



#58 T7 x2



#59 M4-1 x12



#60 SF x1



#61 M4-2 x2



#62 PZ x4



#63 PZ1 x4

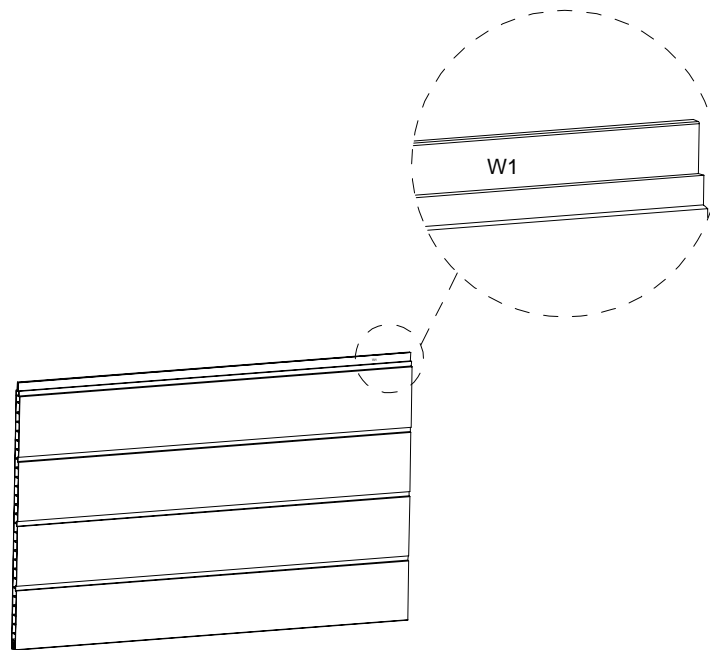

The labels for plastic sheets are usually printed on the latch part, and the specific position is shown in the attached drawing. If there is no latch head, the labels will be affixed to the sheets with adhesive stickers. Before installation, please check whether the sheet labels correspond to the installation steps to avoid affecting the installation.

Please install the screws strictly according to the instructions in the manual and fasten them at the positions shown in the diagrams. This will help avoid issues such as an insufficient number of screws or inadequate assembly strength caused by drilling incorrect screw holes or missing required ones, which may affect the product's proper use.

The metal parts are pre-drilled with screw holes, so the screws should be installed directly into these pre-drilled holes. The panels do not have pre-drilled holes; please drive the screws directly at the positions indicated in the manual diagrams. No additional drilling is required.

Please read the following carefully before assembling

1. Choose a dry and calm day for assembly. Teamwork is required — at least two people should work together.
2. Wear safety gloves, goggles, and long sleeves during assembly to prevent injury. Be careful of sharp edges on certain parts.
3. Keep children and pets away from the construction area.
4. Never place your full weight on the top of the product. If using a ladder, make sure it is stable and in safe condition.

Warning: Do not install in windy weather!



Maintenance and Care:

1. Keep the product clean with a soft cloth; use water when necessary.
2. Remove dust and any debris that may block or affect smooth operation.
3. Use proper tools to clear snow buildup to ensure safe use. Heavy snow may cause collapse — please check for safety before use.
4. This product is intended for storage purposes only.

STEP 1 Base Plate Assembly & Installation

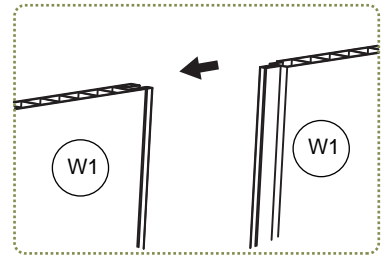
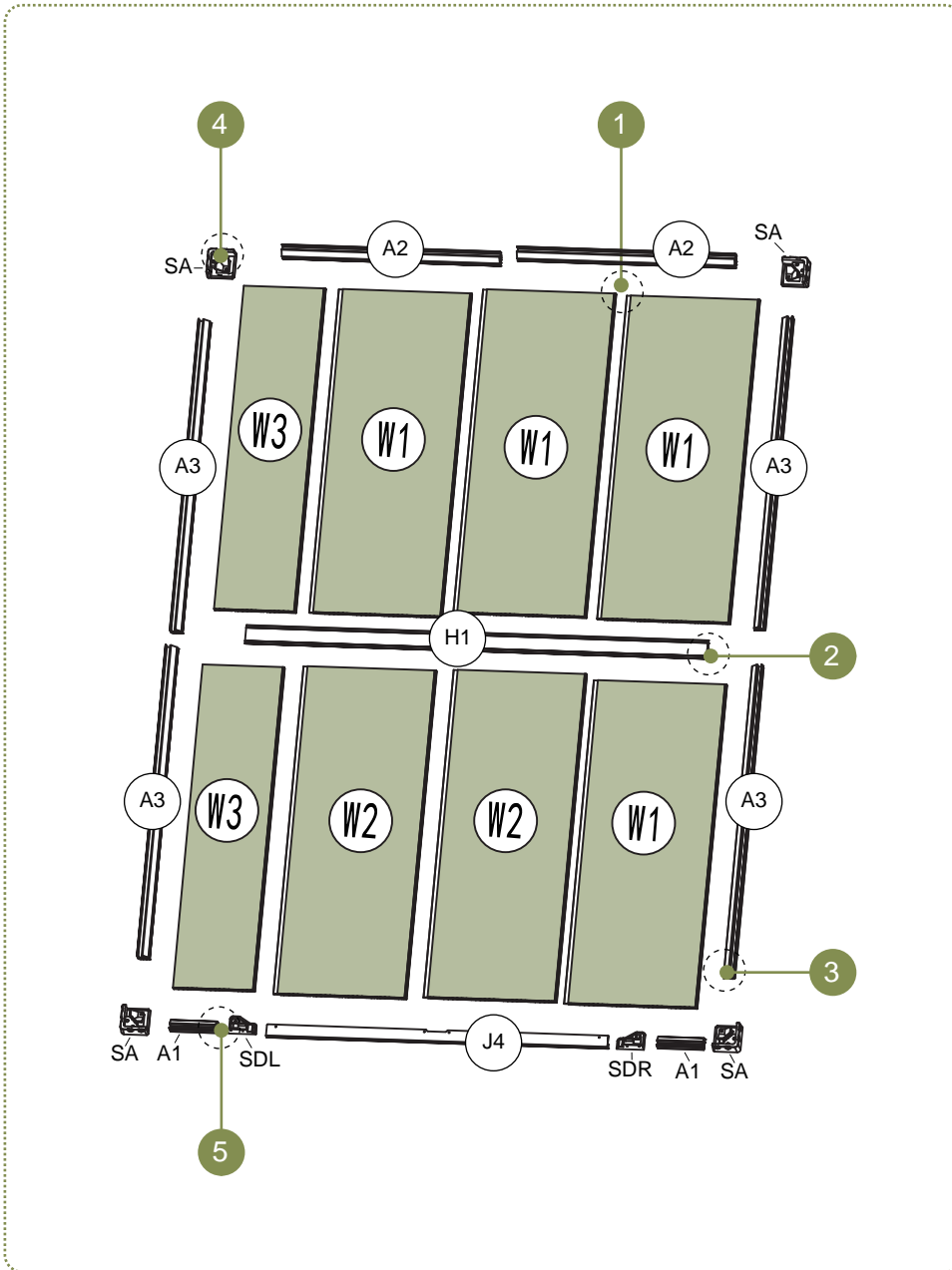

1. After W1 and W1 are installed and joined, with no gaps, it is considered properly installed.

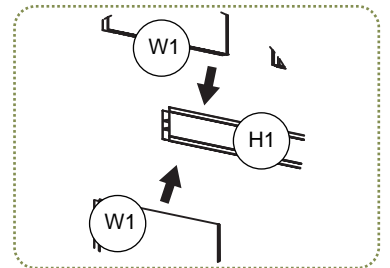

2. After W1 and H1 are installed and joined, with no gaps, it is considered properly installed.

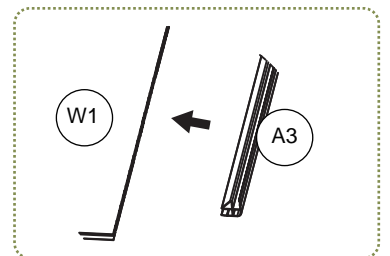

3. After W1 and A3 are installed and joined, with no gaps, it is considered properly installed.

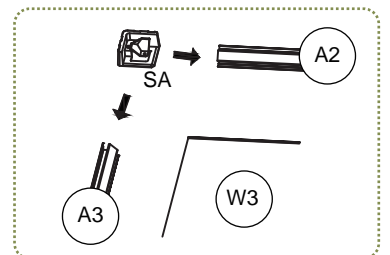

4. After SA, A2, A3 and W3 are installed and joined, with no gaps, it is considered properly installed.

List:

1 W1	x4	5 A2	x2	9 SDR	x1
2 W2	x2	6 A3	x4	10 J4	x1
3 W3	x2	7 SA	x4	11 H1	x1
4 A1	x2	8 SDL	x1		

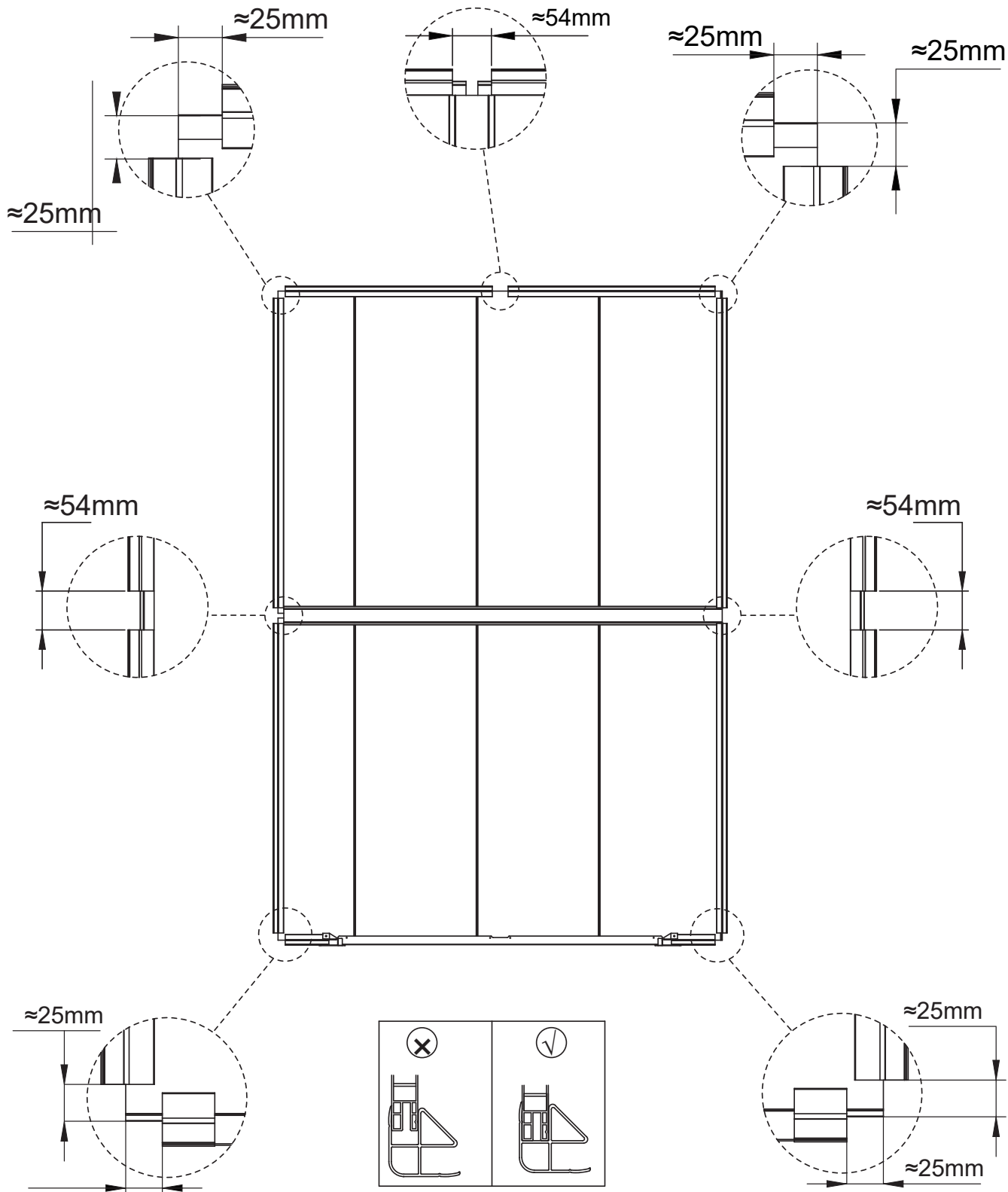

STEP 2 Base Plate Assembly & Installation

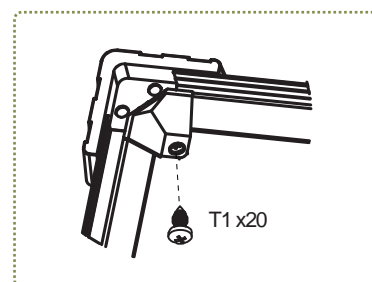
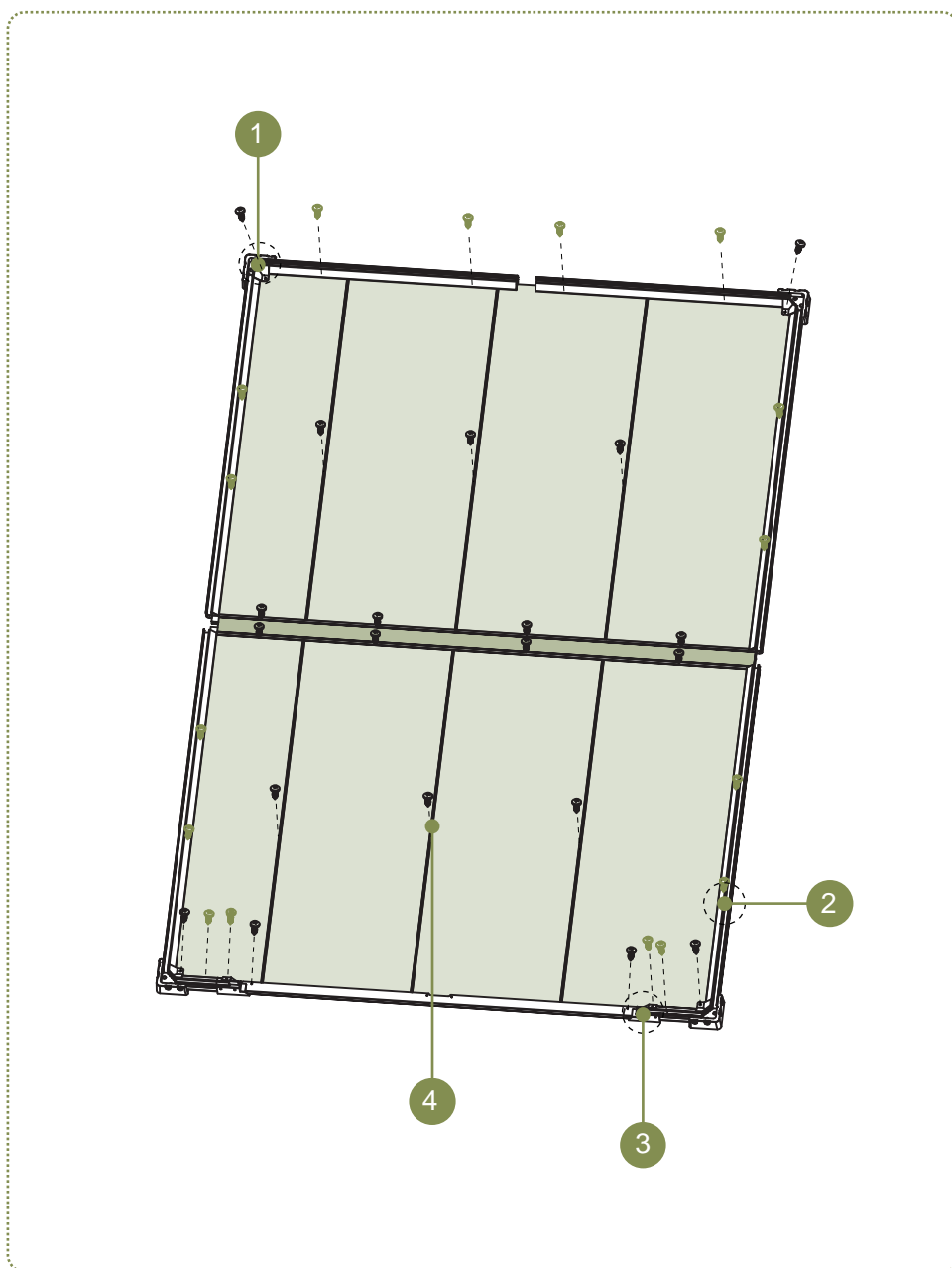

1. Install the screws according to the pre-drilled holes.

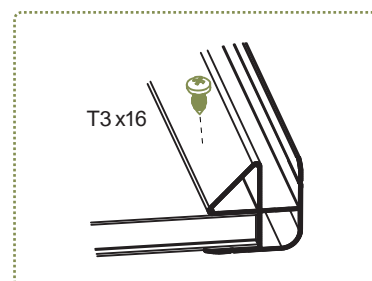

2. The screw is installed at the center of the inclined plane.

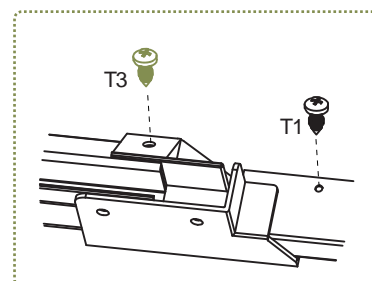

3. Install the screws according to the pre-drilled holes.

4. Install the screws as shown in the diagram. There are no pre-drilled holes at this location, so please drive the screws directly into the recessed groove of the panel. All indicated groove positions are on the inner side of the panel.

List:

1 T1



2 T3



STEP 3 Install W4 & GC

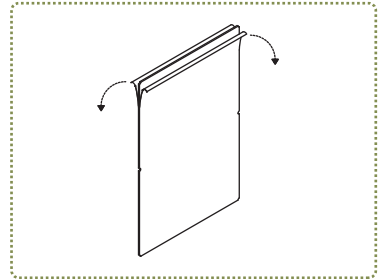
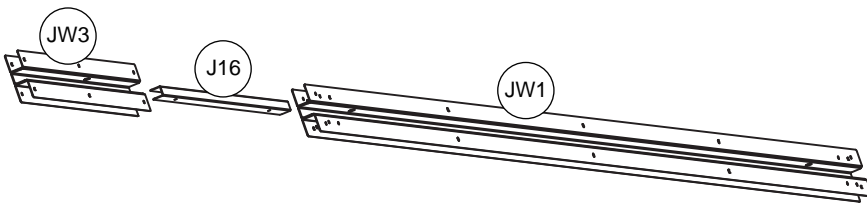
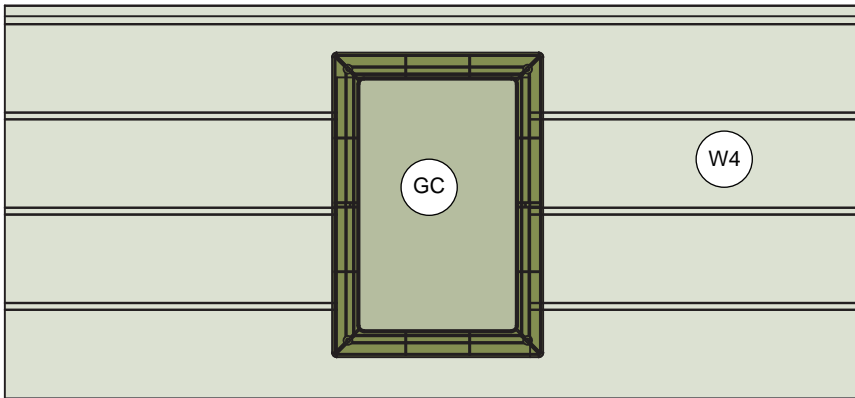

1. Remove the protective film before installing the window, and install it according to the diagram.

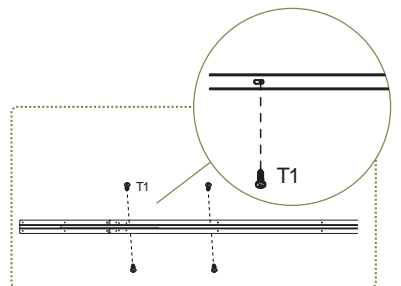
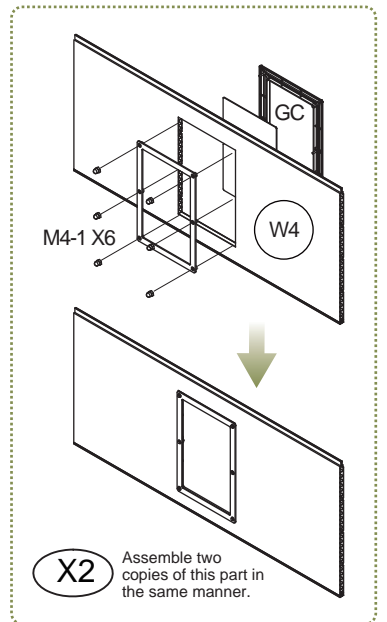

List:

1 M4-1



2 GC



3 W4



4 JW3



5 J16

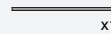

6 JW1



7 T1



2. After splicing JW1 and JW3, insert J16 into the groove and check whether the left and right assembly holes are aligned. If the holes are misaligned, try reversing J16 and rechecking. After confirming that the holes are correctly aligned, install the screws to lock the assembly in place.

STEP 4 Post Assembly & Wall Installation

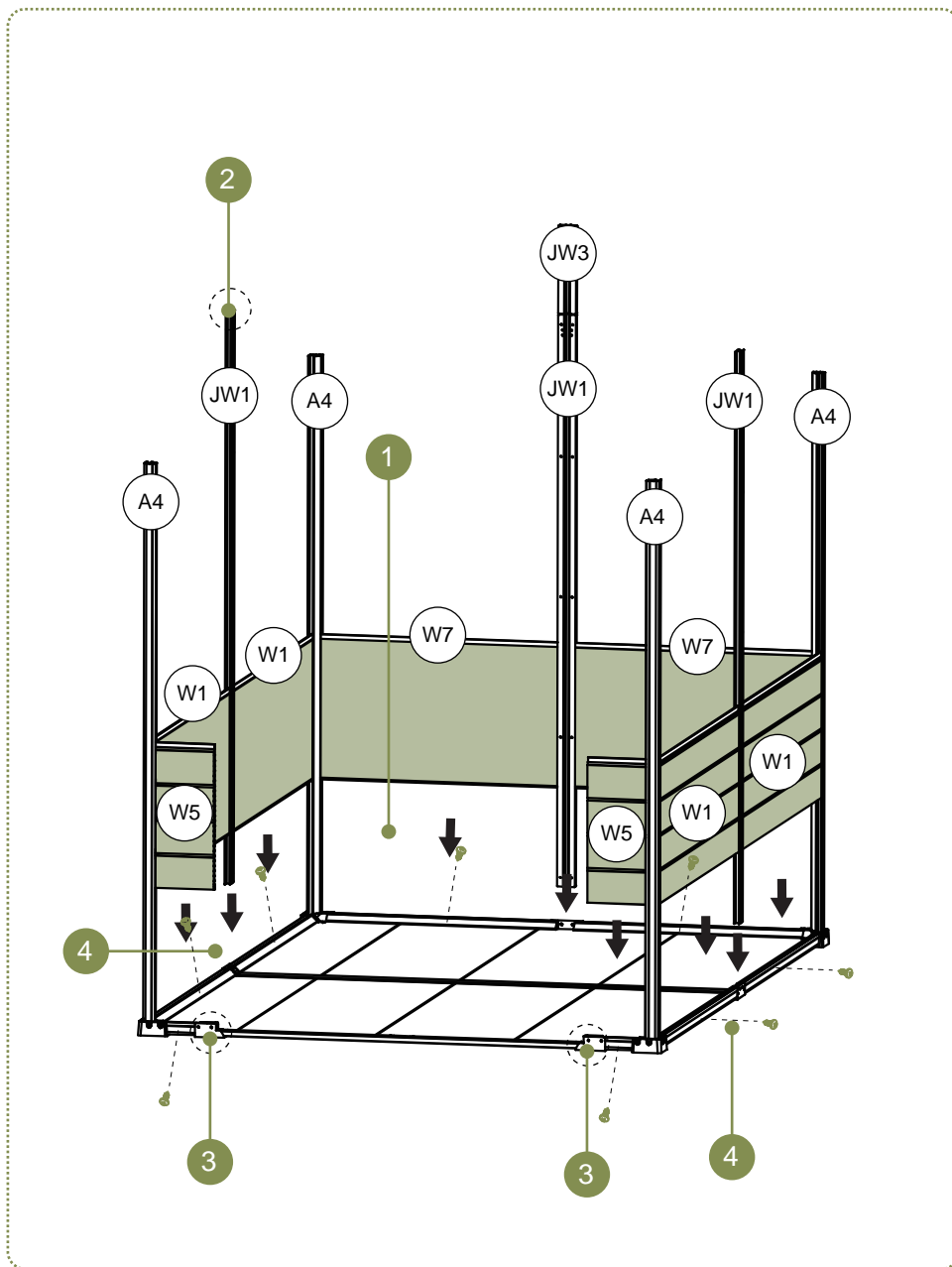

1. When inserting the sheet material, be sure to push it fully into place with no gaps left. Align the wood grain pattern correctly so that it faces outward. Position the latch part on top and the groove part at the bottom.



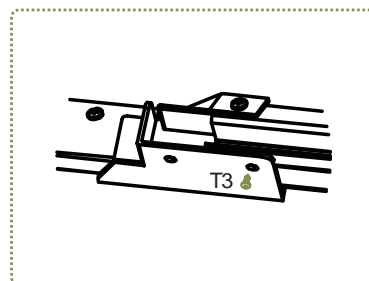

2. The notches shall be installed uniformly facing inward.





3. Drill and tighten the T3 screws into the pre-drilled screw holes of parts SDL and SDR according to the positions shown in the diagram.

4. Fix the screws according to the diagram.

List:

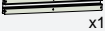
1 W1	 x4
2 W7	 x2
3 W5	 x2
4 JW1	 x3

5 JW3	 x1
6 A4	 x4
7 T3	 x10

STEP 5 Post Assembly & Wall Installation

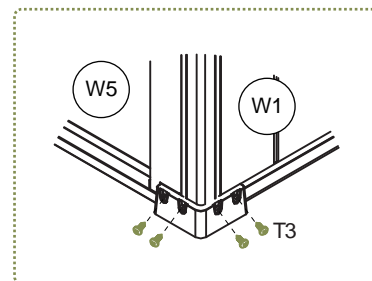
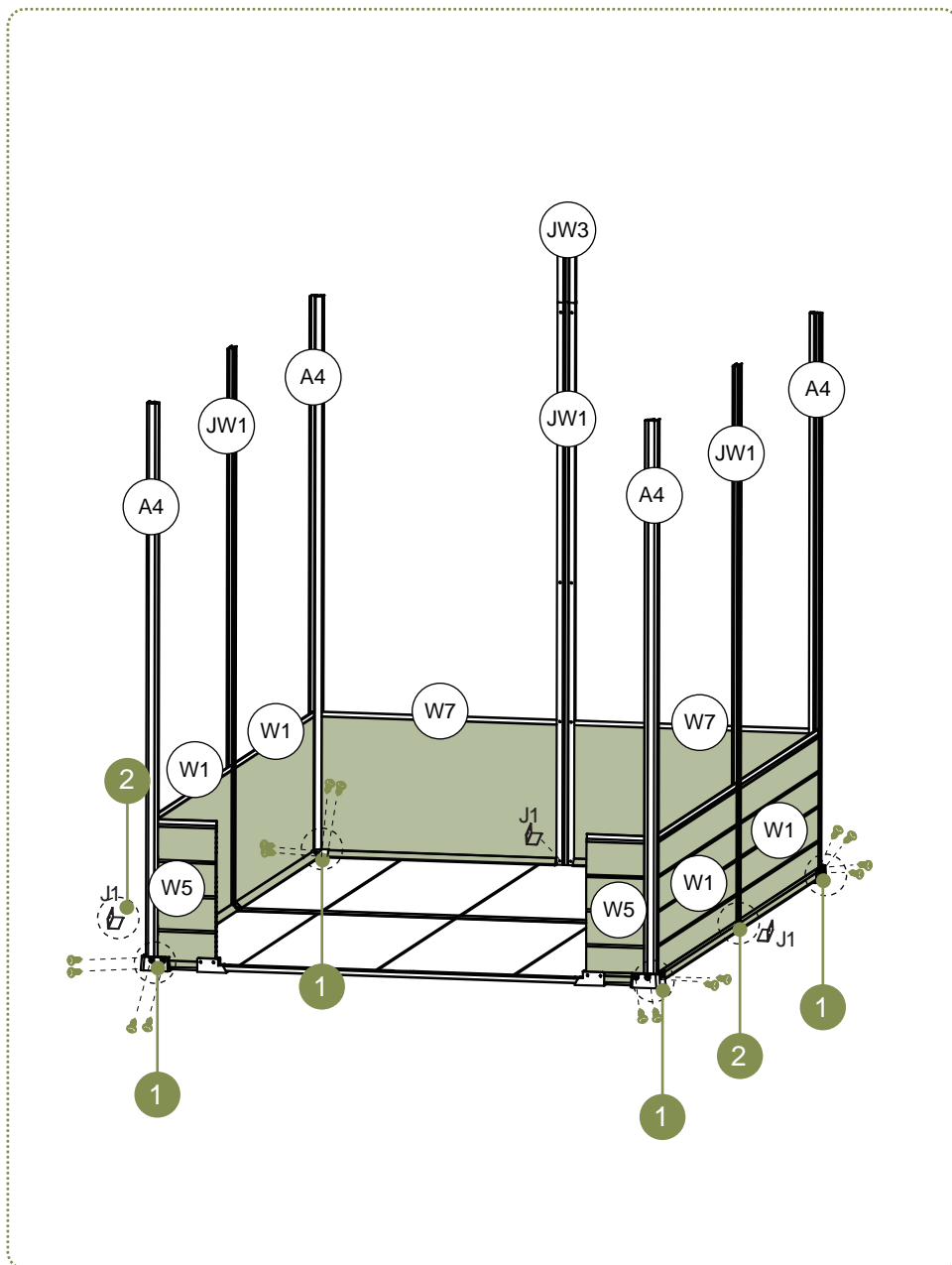

1. Install the screws according to the pre-drilled holes.

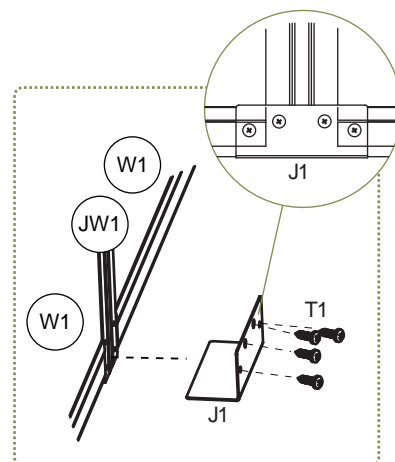

2. Follow the diagram to drill and screw into the pre-made holes in the parts.

List:

1 J1



2 T1



3 T3



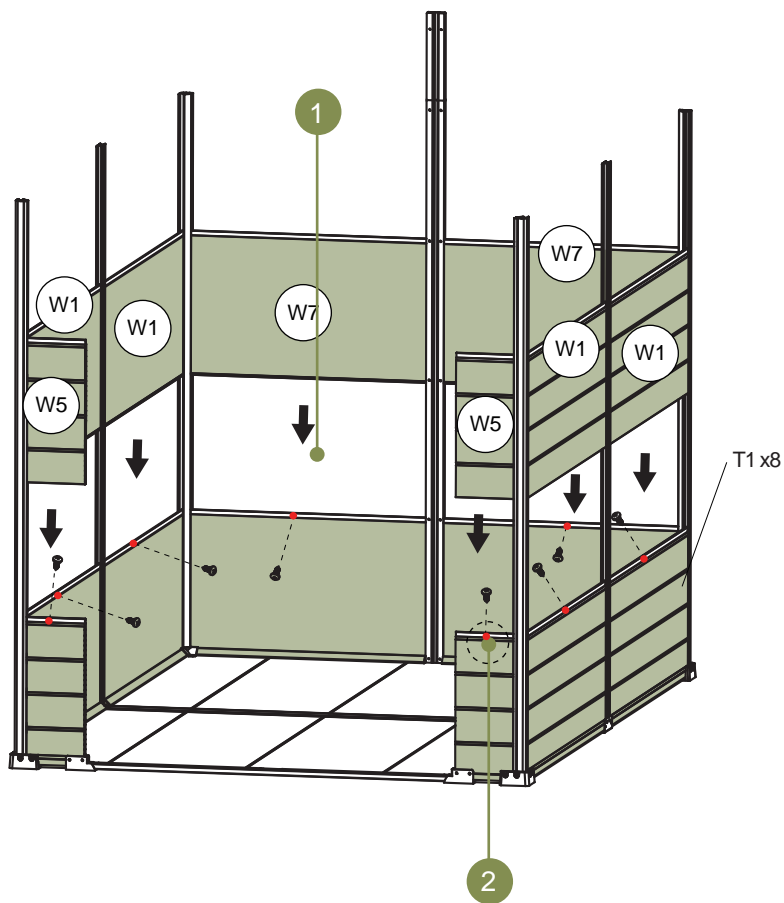

STEP 6 Wall Installation



1. When inserting the sheet material, be sure to push it fully into place with no gaps left. Align the wood grain pattern correctly so that it faces outward. Position the latch part on top and the groove part at the bottom.

2. Install the screws as shown in the diagram. There are no pre-drilled holes at this location, so please drive the screws directly into the recessed groove of the panel. All indicated positions are on the inner side of the panel.

List:

- | | | |
|---|----|--|
| 1 | W1 |  x4 |
| 2 | W7 |  x2 |
| 3 | W5 |  x2 |
| 4 | T1 |  x8 |

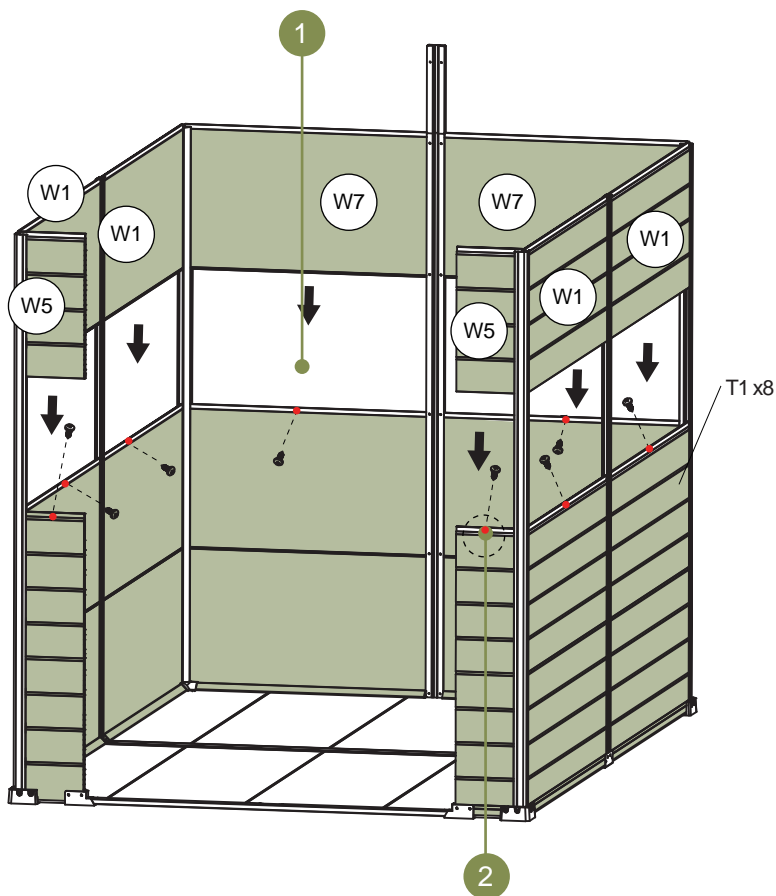

STEP 7 Wall Installation



1. When inserting the sheet material, be sure to push it fully into place with no gaps left. Align the wood grain pattern correctly so that it faces outward. Position the latch part on top and the groove part at the bottom.

2. Install the screws as shown in the diagram. There are no pre-drilled holes at this location, so please drive the screws directly into the recessed groove of the panel. All indicated positions are on the inner side of the panel.

List:



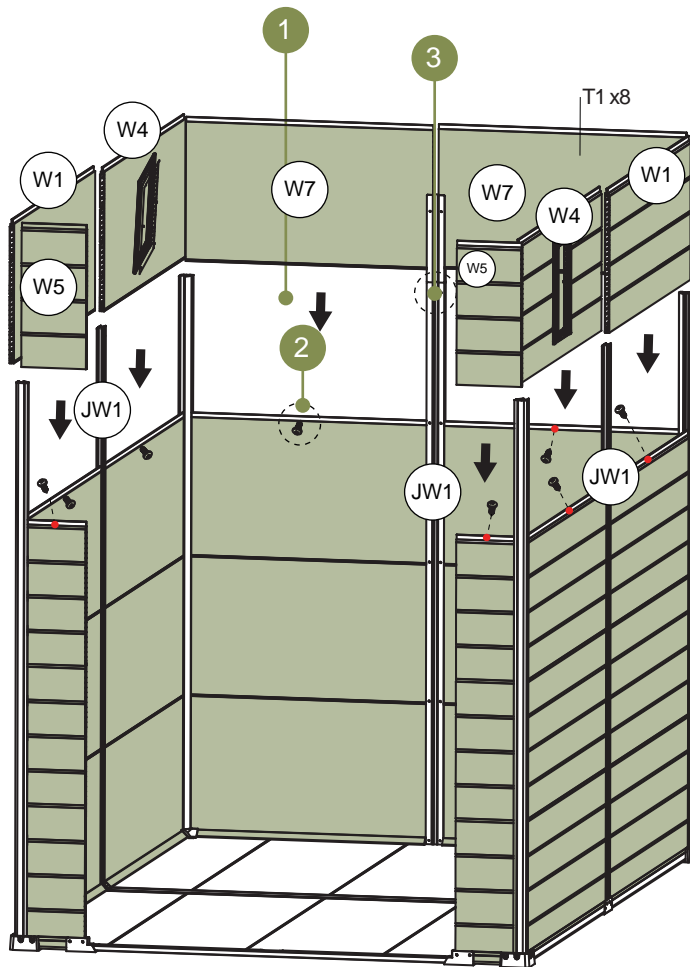

- | | |
|------|--|
| 1 W1 |  x4 |
| 2 W7 |  x2 |
| 3 W5 |  x2 |
| 4 T1 |  x8 |

STEP 8 Wall Installation



Tip: Repeat the steps above once more for a final total of two complete roof panels.

List:

- | | | | | | |
|---|----|--|---|----|--|
| 1 | W1 |  x2 | 5 | T1 |  x26 |
| 2 | W7 |  x2 | | | |
| 3 | W5 |  x2 | | | |
| 4 | W4 |  x2 | | | |

1. When inserting the sheet material, be sure to push it fully into place with no gaps left. Align the wood grain pattern correctly so that it faces outward. Position the latch part on top and the groove part at the bottom.

2. Install the screws as shown in the diagram. There are no pre-drilled holes at this location, so please drive the screws directly into the recessed groove of the panel. All indicated positions are on the inner side of the panel.

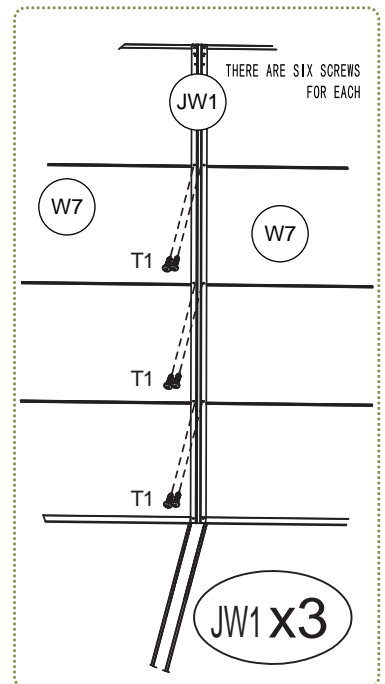

3. A total of three JW1 components need to be installed. Each JW1 component is secured with six T1 screws. The T1 screws are fastened on the inner side of the panel, and no screws are required on the outer side.

STEP 9 Post Installation & Installation of L2 & L3

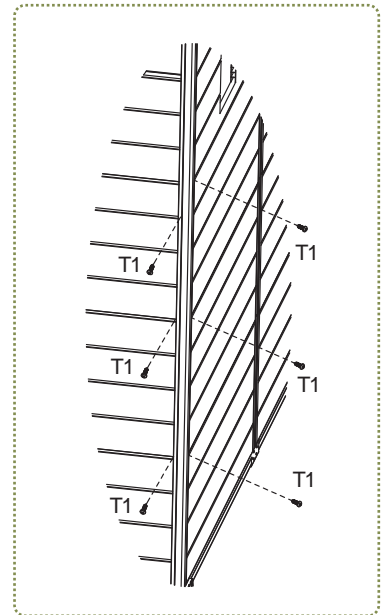
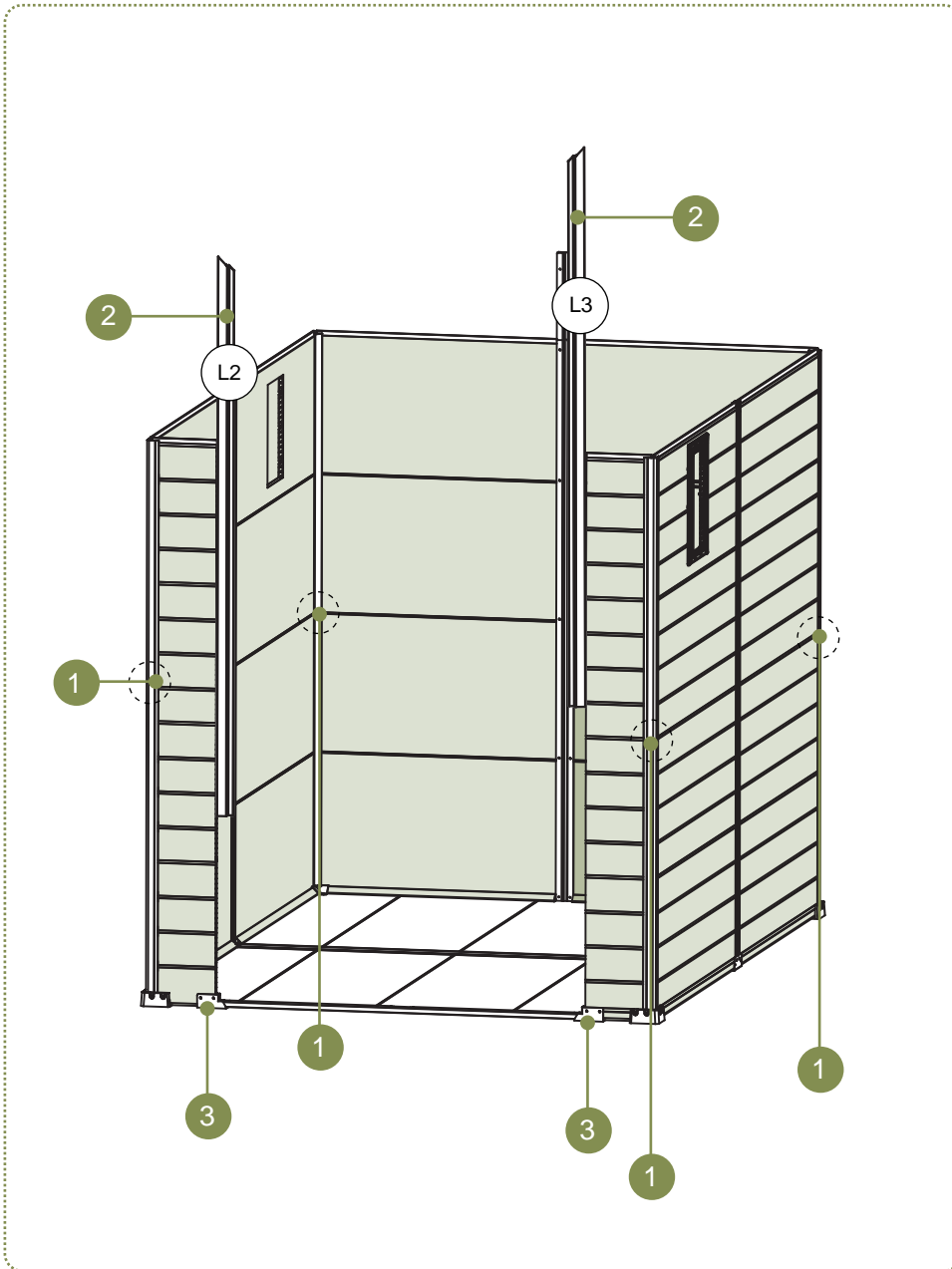

1. Please install the screws according to the diagram. There are no pre-drilled holes at this location. A total of four A4 components need to be installed. Each A4 component is secured with six T1 screws. The T1 screws are fastened on the outer side of the A4 upright, and no screws are required on the inner side.

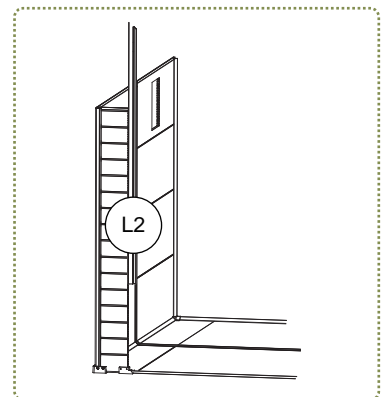

2. Insert the door frame as shown in the diagram, making sure it is pushed in fully and securely seated.

List:

- 1** L2  x1
- 2** L3  x1
- 3** T1  x24
- 4** T5  x2

STEP 9 Post Installation & Installation of L2 & L3

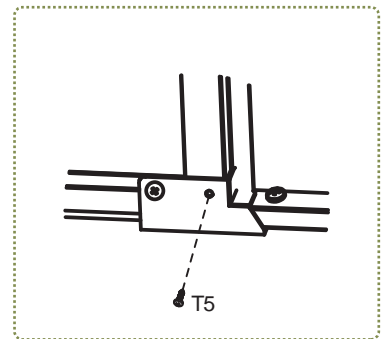
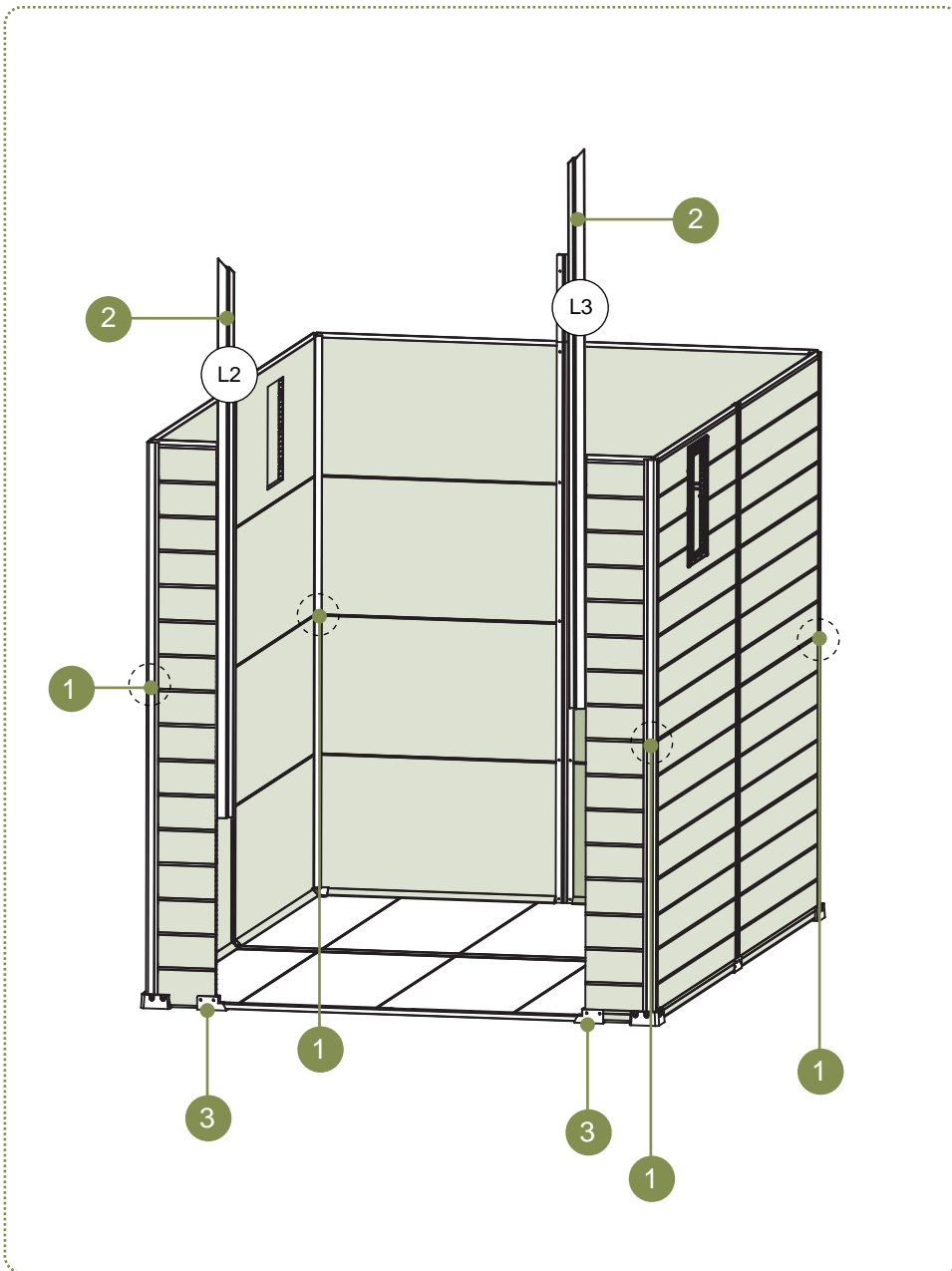

3. Screw in according to the positions shown in the diagram.

List:

- 1 L2  x1
- 2 L3  x1
- 3 T1  x24
- 4 T5  x2

STEP 10 Install W6, W8 and W9

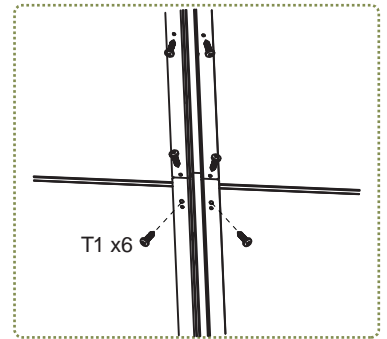
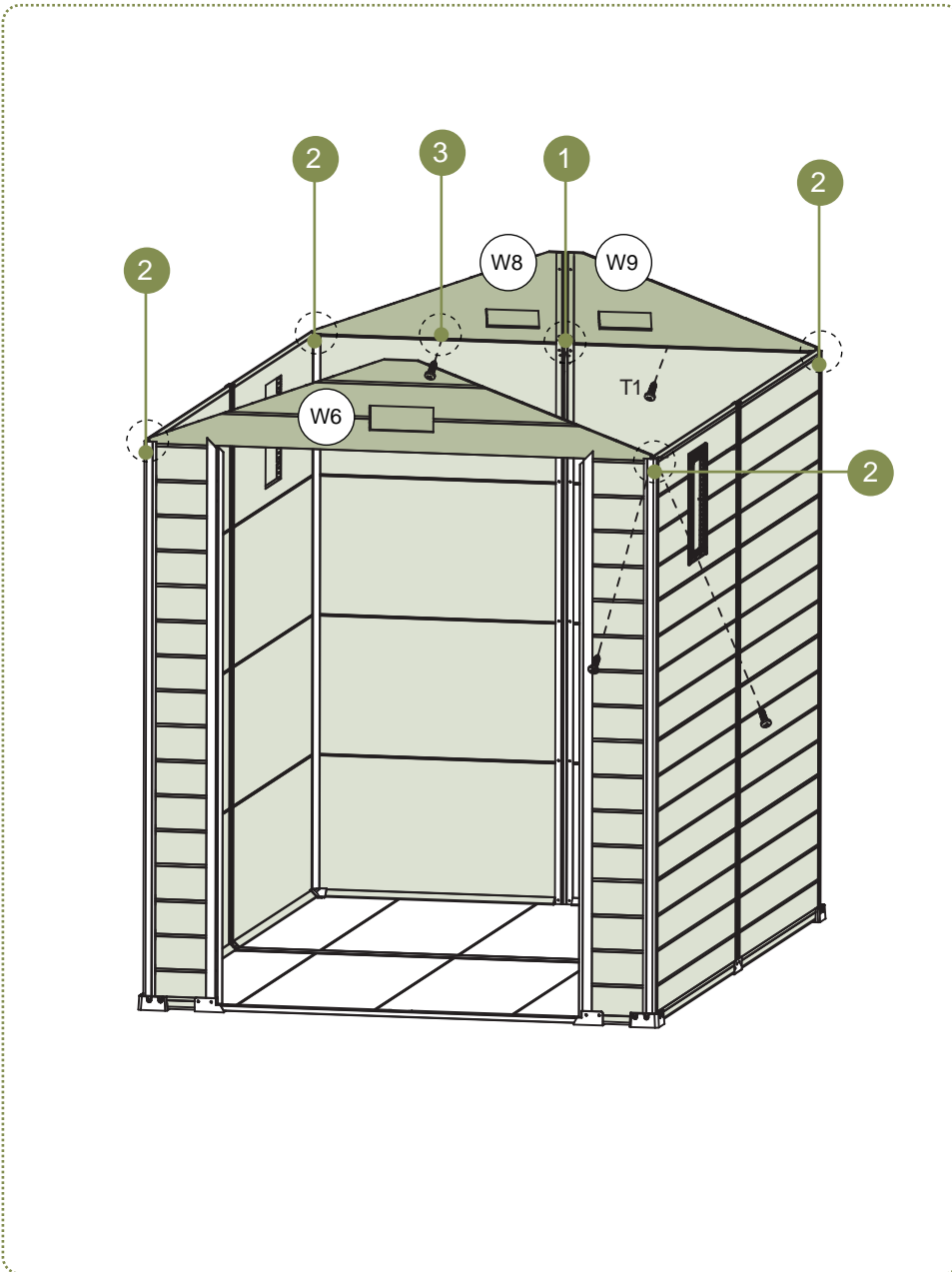

1. Install the screws into the pre-drilled indents as shown in the diagram. Be careful not to over-tighten them, as this could strip the holes or damage the board.



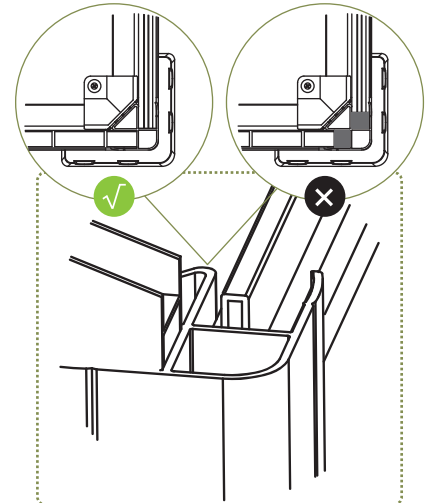

No gaps Gaps may cause loosening.

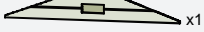

2. Please pay attention to the joint between the plastic panel and the plastic upright, ensuring there are no gaps. Refer to the diagram and use eight T1 screws to fasten the joints between the plastic panels and the plastic uprights. Note: **Do NOT fasten W6 to avoid subsequent interference with the installation of L4.** There are no pre-drilled holes at this location, and all marked installation positions are on the outer side of the panels.

3. According to the diagram, use T1 screws to secure W8 and W9. There are no pre-drilled holes at this location, so please drive the screws directly into the connecting recessed grooves of the top and bottom panels. All indicated positions are on the inner side of the panels.

List:

- 1 W6  x1
- 2 W8  x1
- 3 W9  x1
- 4 T1  x16

STEP 11 Connection and Installation

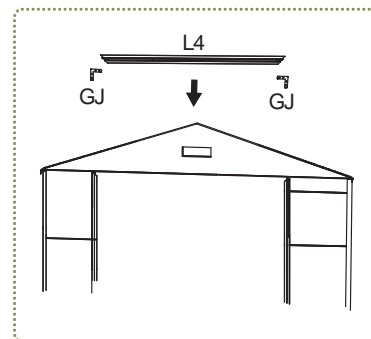
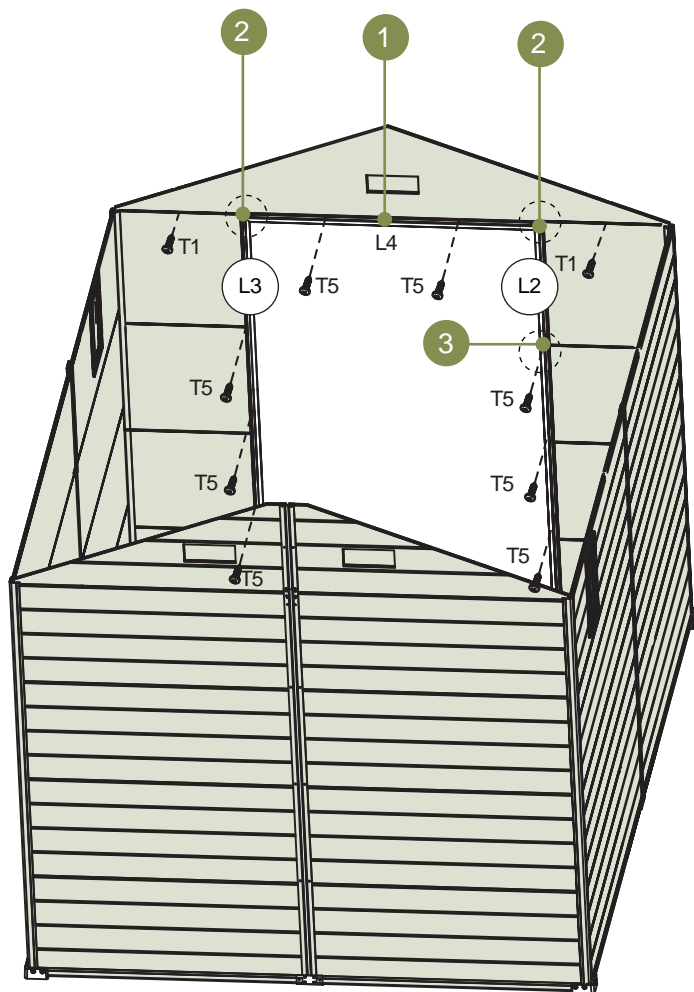

1. Install L4 from indoors, aligning the bevel gaps between L4 and L2/L3, then fix them with GJ as shown in the diagram. Note that there should be no gaps between the aluminum alloy and the sheet material during assembly.

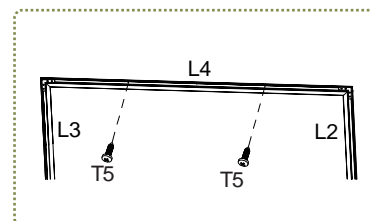



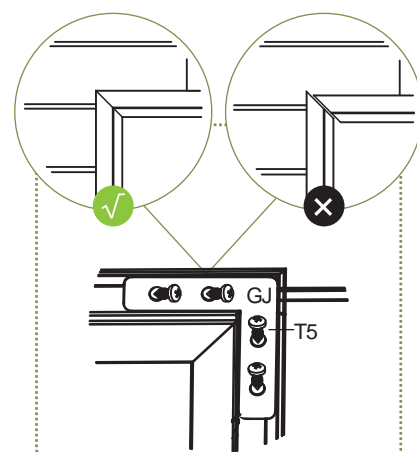

When installing L4, only tighten the screws on the inner side of the shed body.



2. Install the screws in the locations shown in the diagram.

List:



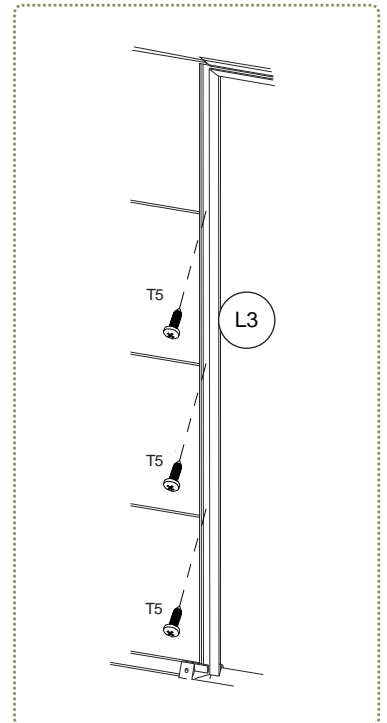
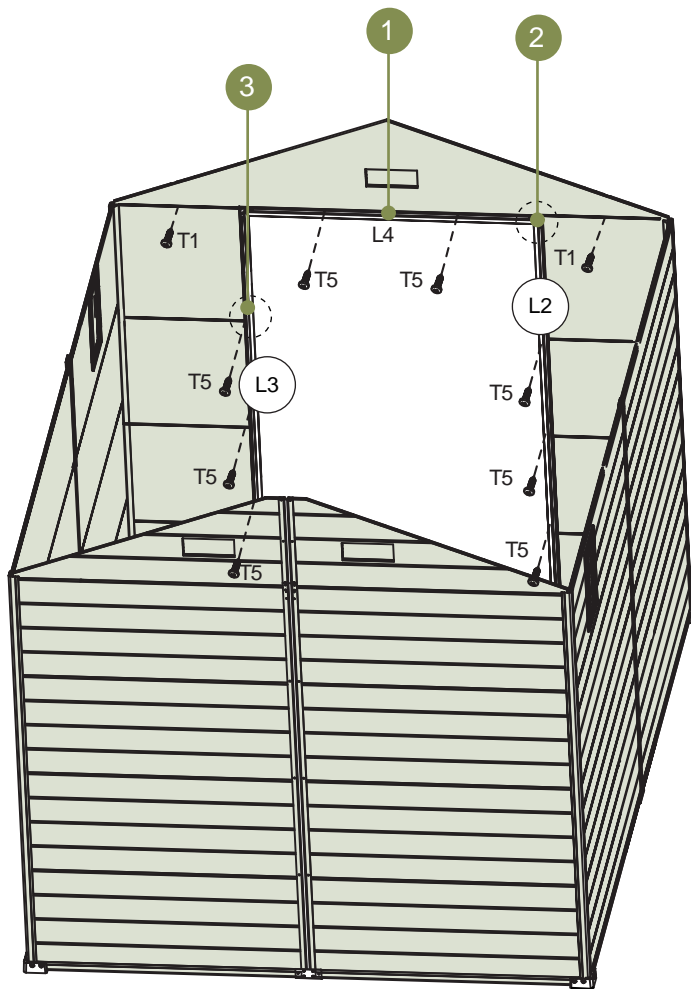

- 1** L4  x1
- 2** GJ  x2
- 3** T1  x2
- 4** T5  x16

STEP 11 Connection and Installation



3. When installing L2 and L3, only tighten the screws on the inner side of the shed body.

List:

- 1 L4  x1
- 2 GJ  x2
- 3 T1  x2
- 4 T5  x16

STEP 12 Install the Main Frame Connectors

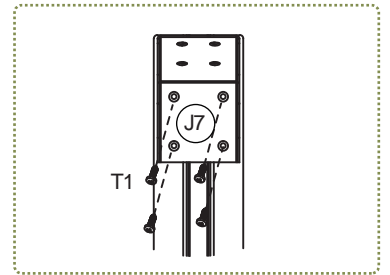
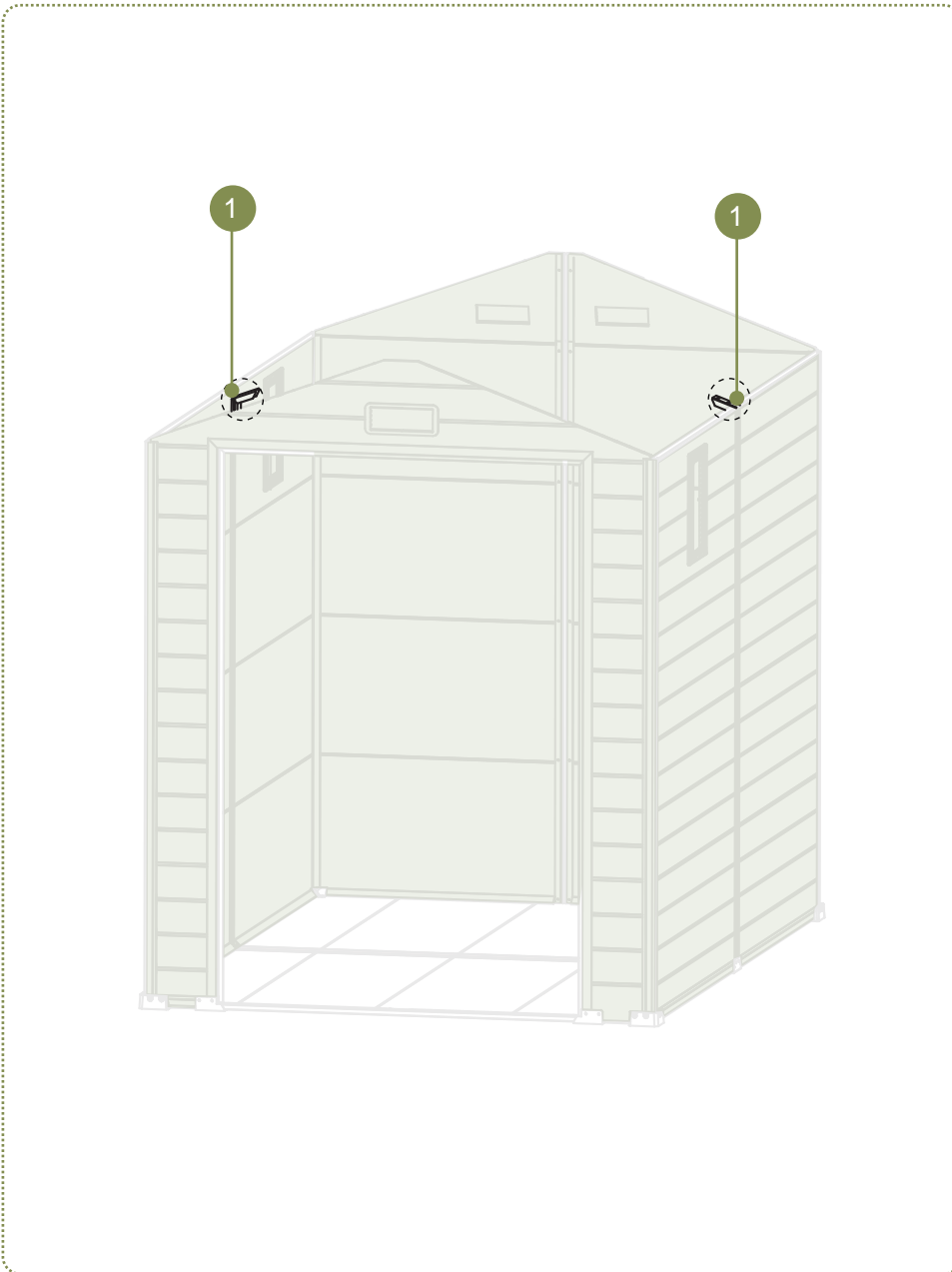

1. Install the screws in the locations shown in the diagram.

List:

1 J7



2 T1



STEP 13 Install the Main Frame

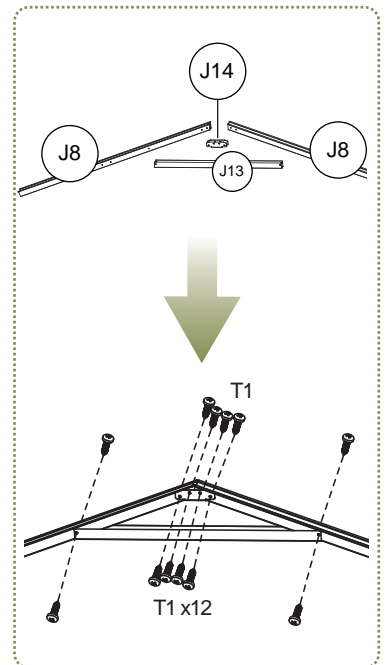
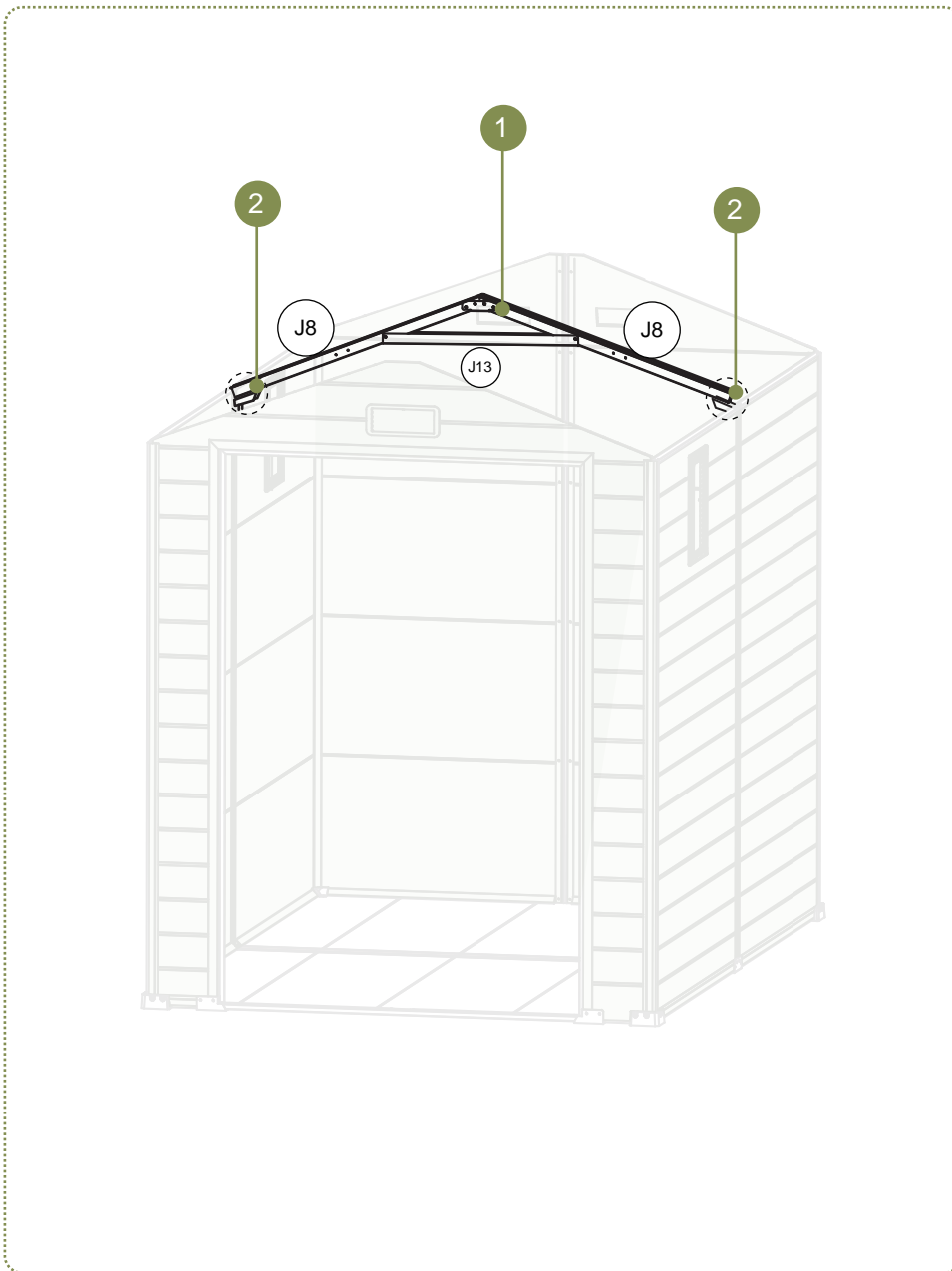



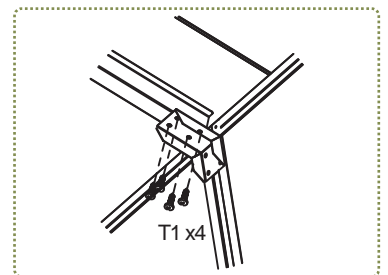

1. Install the screws in the locations shown in the diagram.



2. Install the screws in the locations shown in the diagram.

List:

- 1 J8  x2
- 2 J14  x1
- 3 J13  x1
- 4 T1  x20

STEP 14 Install the Roof

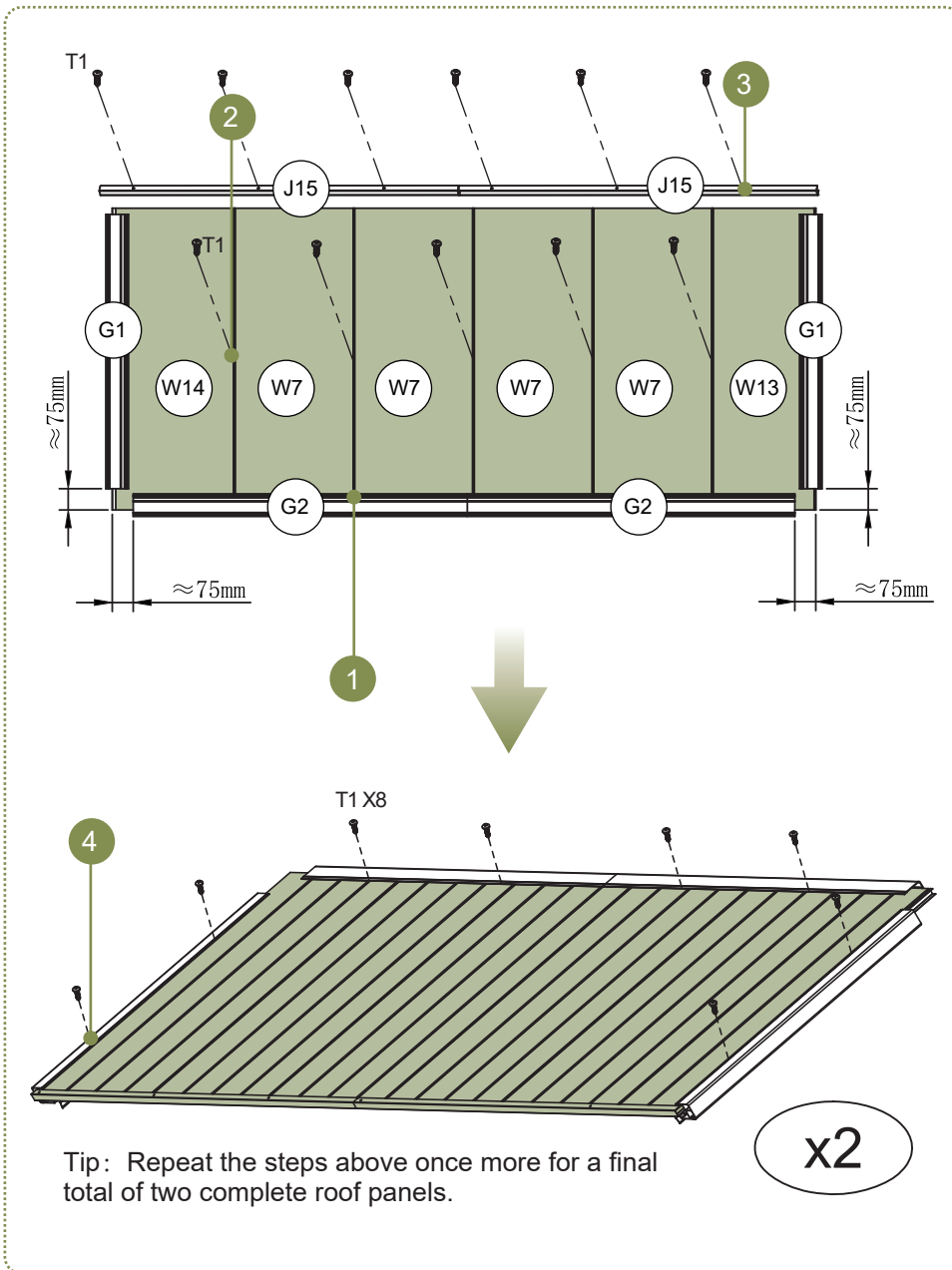

1. Insert components G2 and G1 as shown in the diagram. Ensure they are fully seated in the profiles with no gaps. Maintain a 75mm margin from all four corners.

2. Install the screws as shown in the diagram. There are no pre-drilled holes at this location, so please drive the screws directly into the recessed groove of the panel. All indicated positions are on the inner side of the panel.

3. According to the diagram, two J15 components need to be installed. Please drive six screws directly into the pre-drilled holes of J15. Be sure to distinguish the front and back sides of the panels. All indicated positions are on the inner side of the panels.

4. According to the diagram, install eight T1 screws into G1 and G2 at the edge of the panel. There are no pre-drilled holes at this location, so please drive the screws directly through G1, G2, and the outer side of the panel. All indicated positions are on the outer side of the panel.

List:

1 W7



x8

2 W13



x2

3 W14



x2

4 G1



x4

5 T1



x38

6 G2



x4

7 J15



x4

STEP 15 Roof Installation and Assembly

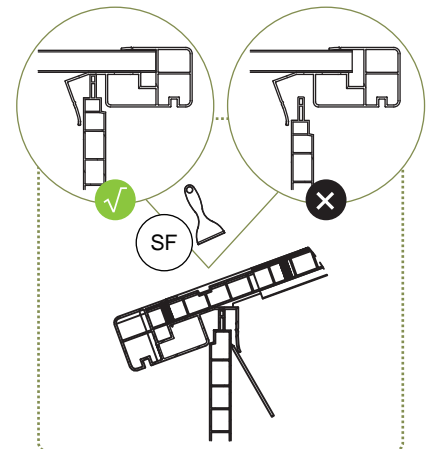
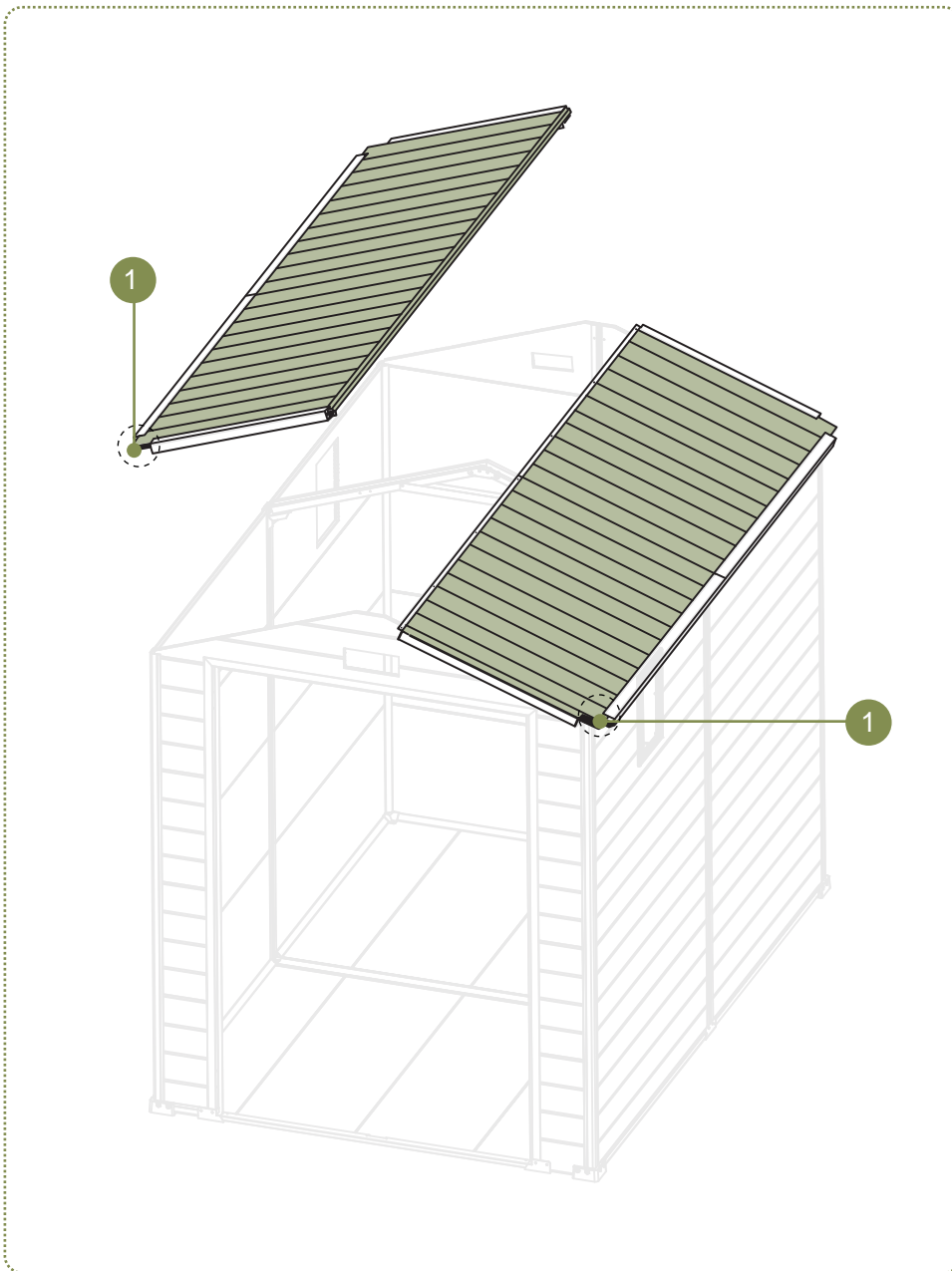

1. Use the SF (tool/component) to ensure all panels are fully inserted into the G-profile and are completely seated.

List:

1 SF



STEP 16 Roof Installation and Assembly

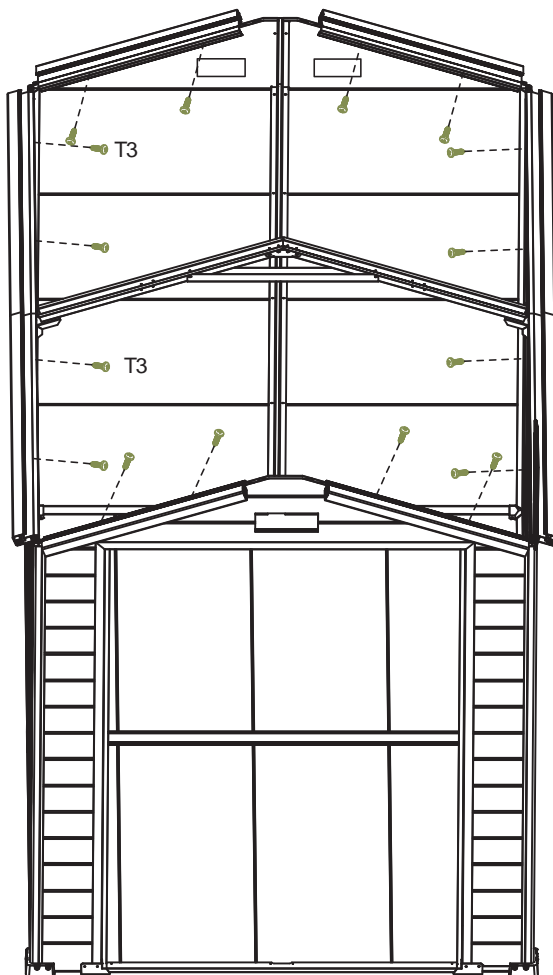

1. Install the T3 screws through the pre-grooved channel of the G-profile at an upward angle to connect the panel to the profile.

List:

1 T3



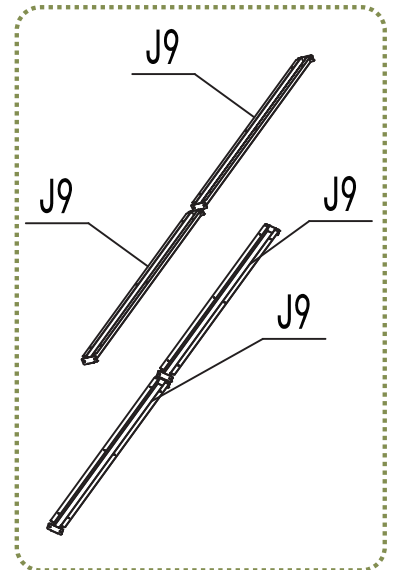
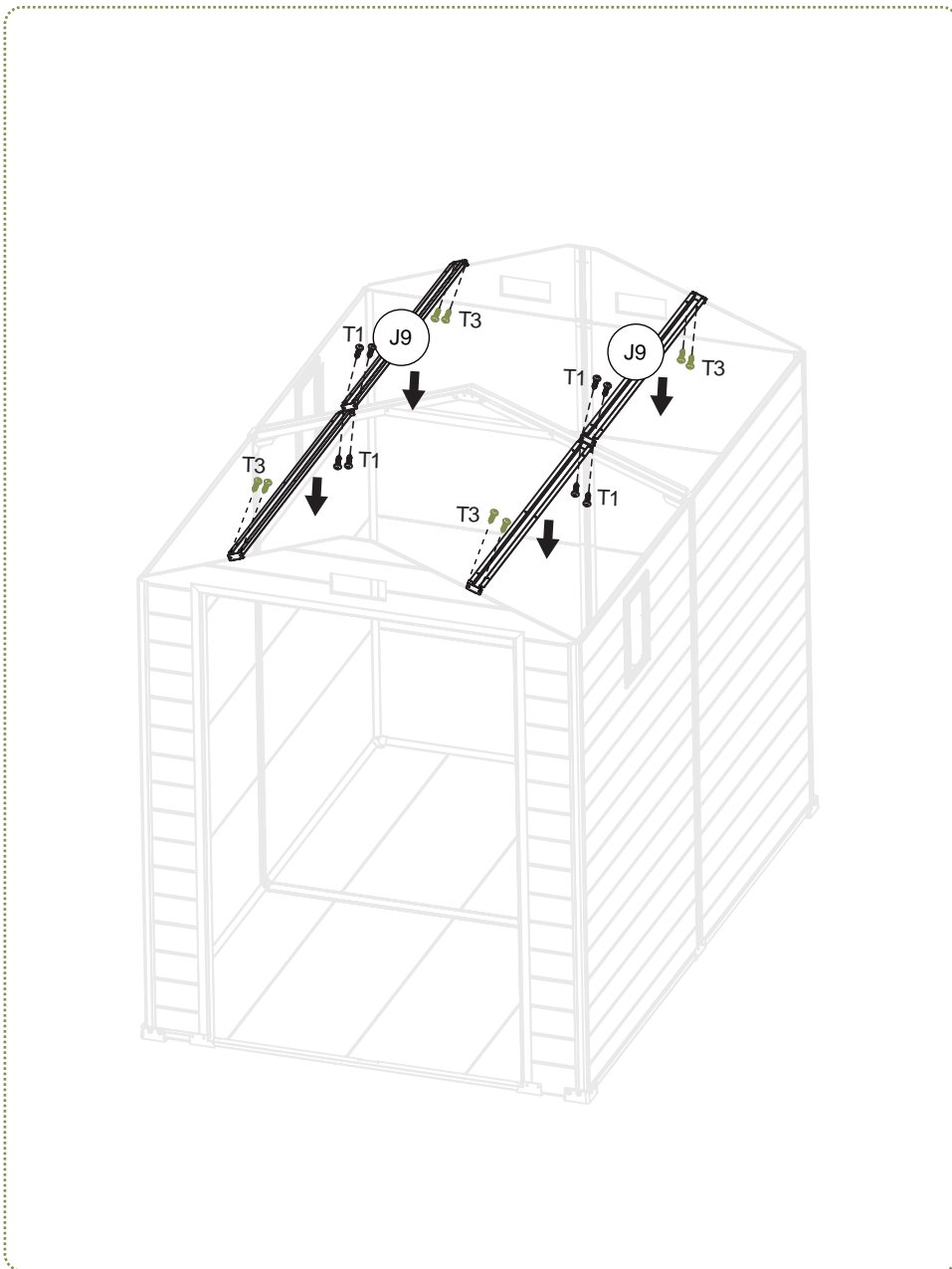

STEP 17 Install the Beams



1. First, connect two J9 pieces together to form one long J9, then secure it to the frame with screws.

List:

- | | |
|------|--|
| 1 J9 |  x4 |
| 2 T1 |  x8 |
| 3 T3 |  x8 |

STEP 18 Beam & Roof Installation

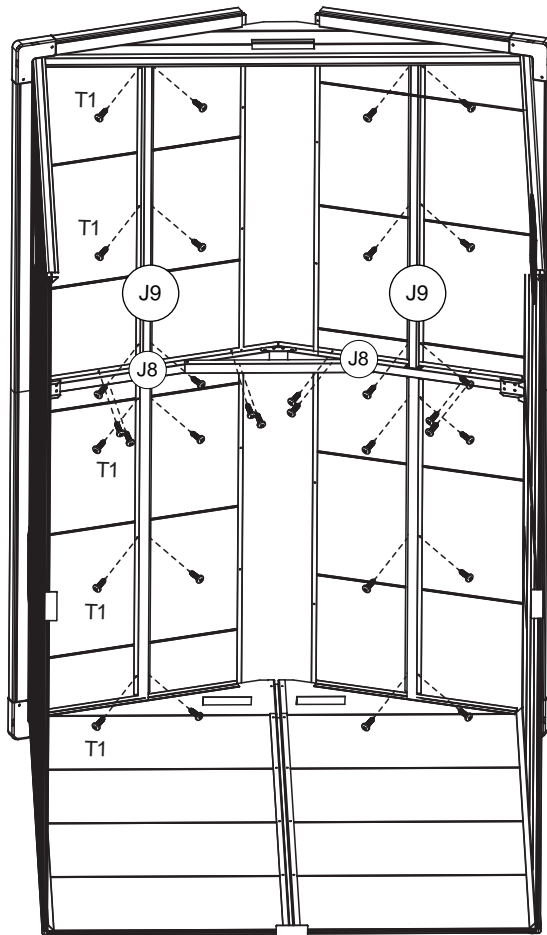

1. Please install the screws according to the diagram. Using the pre-drilled holes in J8 and J9, connect the metal parts to the roof panel by driving the T1 screws directly into the pre-drilled holes and the panel. All indicated positions are on the inner side of the panel.

List:

1 T1



STEP 19 Install J17

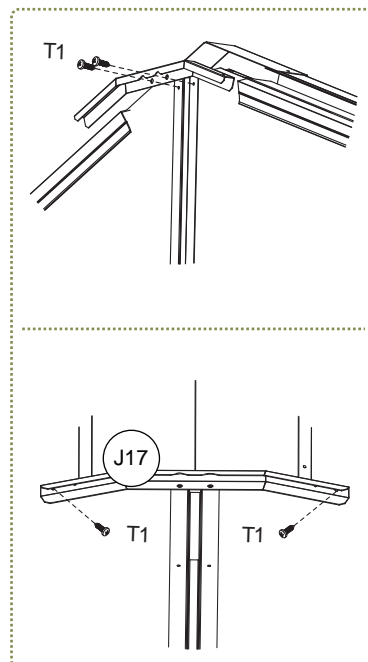
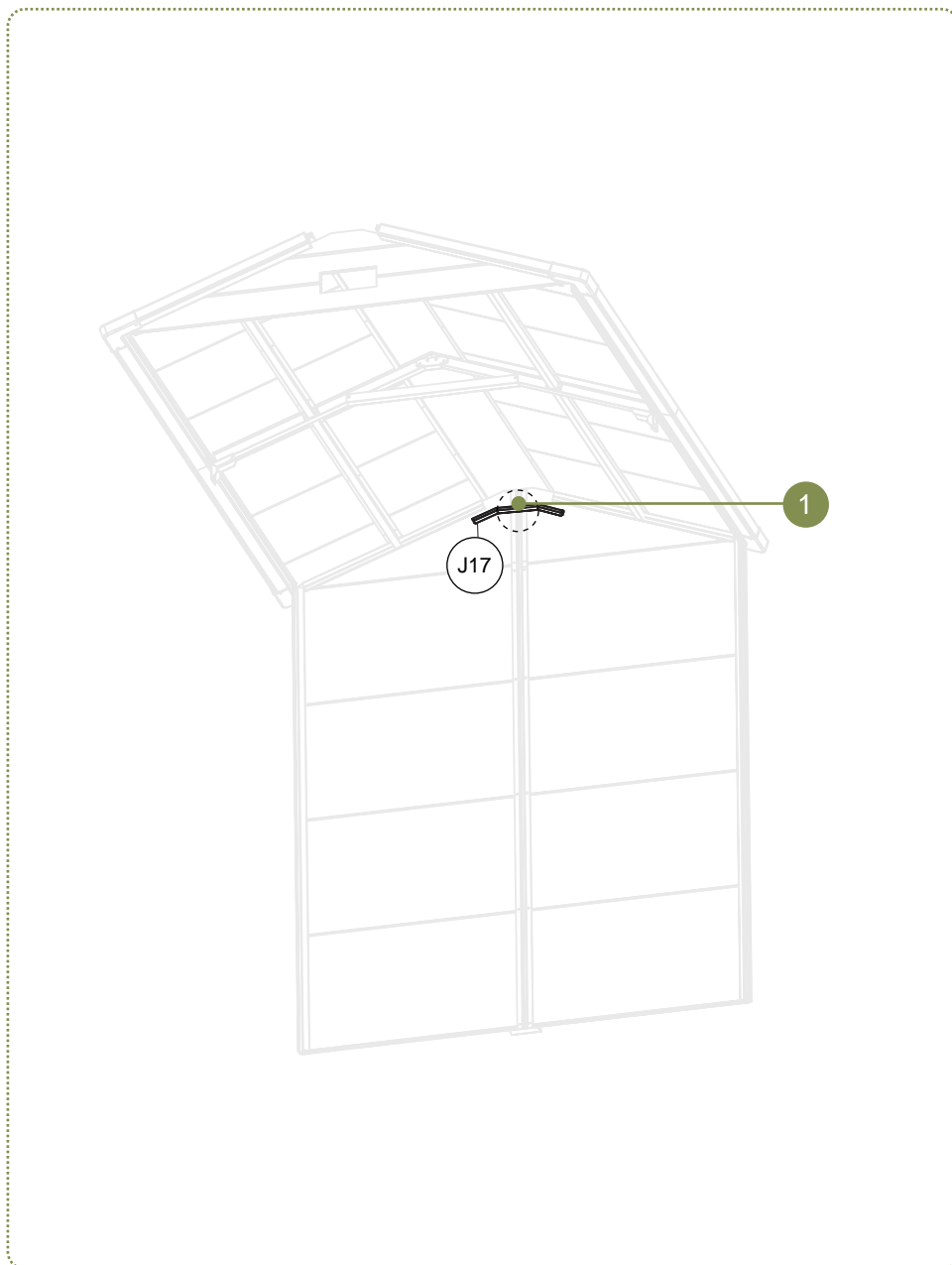

1. Please install the screws according to the diagram, using four T1 screws to secure J17 at the edge of the roof.

List:

1 J17



2 T1



STEP 20 Install J1&SB

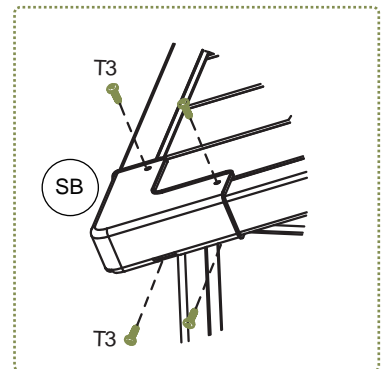
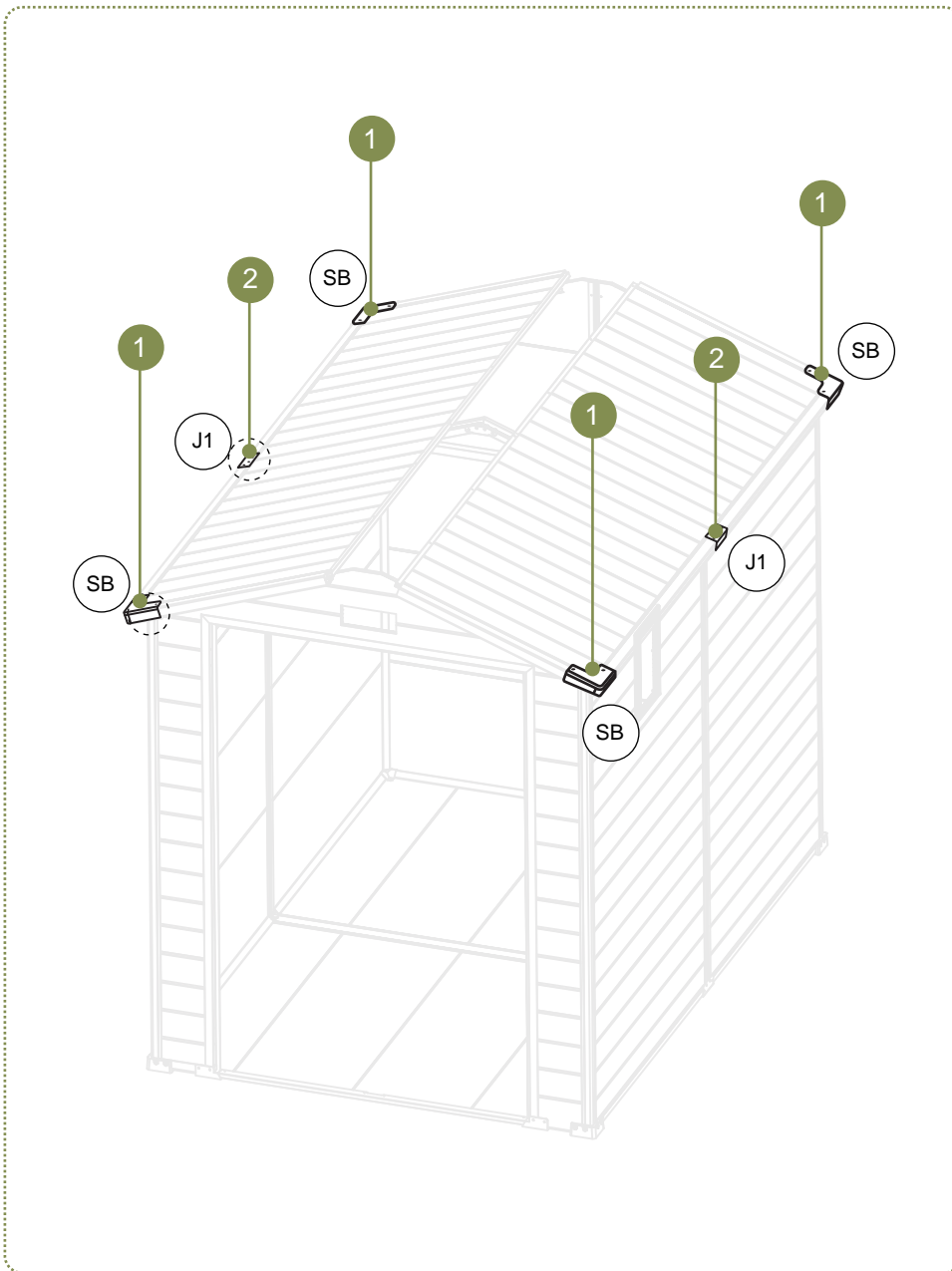

1. Position the SB with the pre-drilled side facing down.

Screw in according to the positions shown in the diagram.

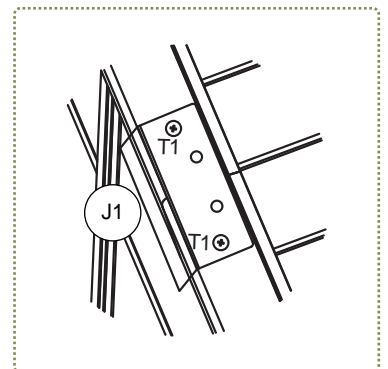

2. Screw in according to the positions shown in the diagram.

List:

1 SB



x4

2 J1

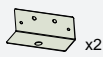

x2

3 T1



x4

4 T3



x16

STEP 21 Install PC2

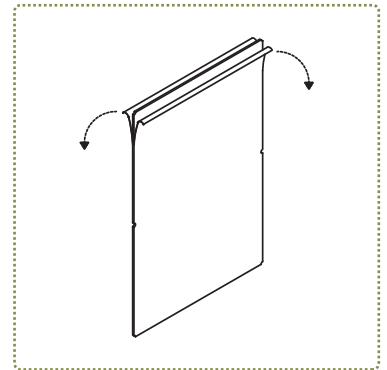
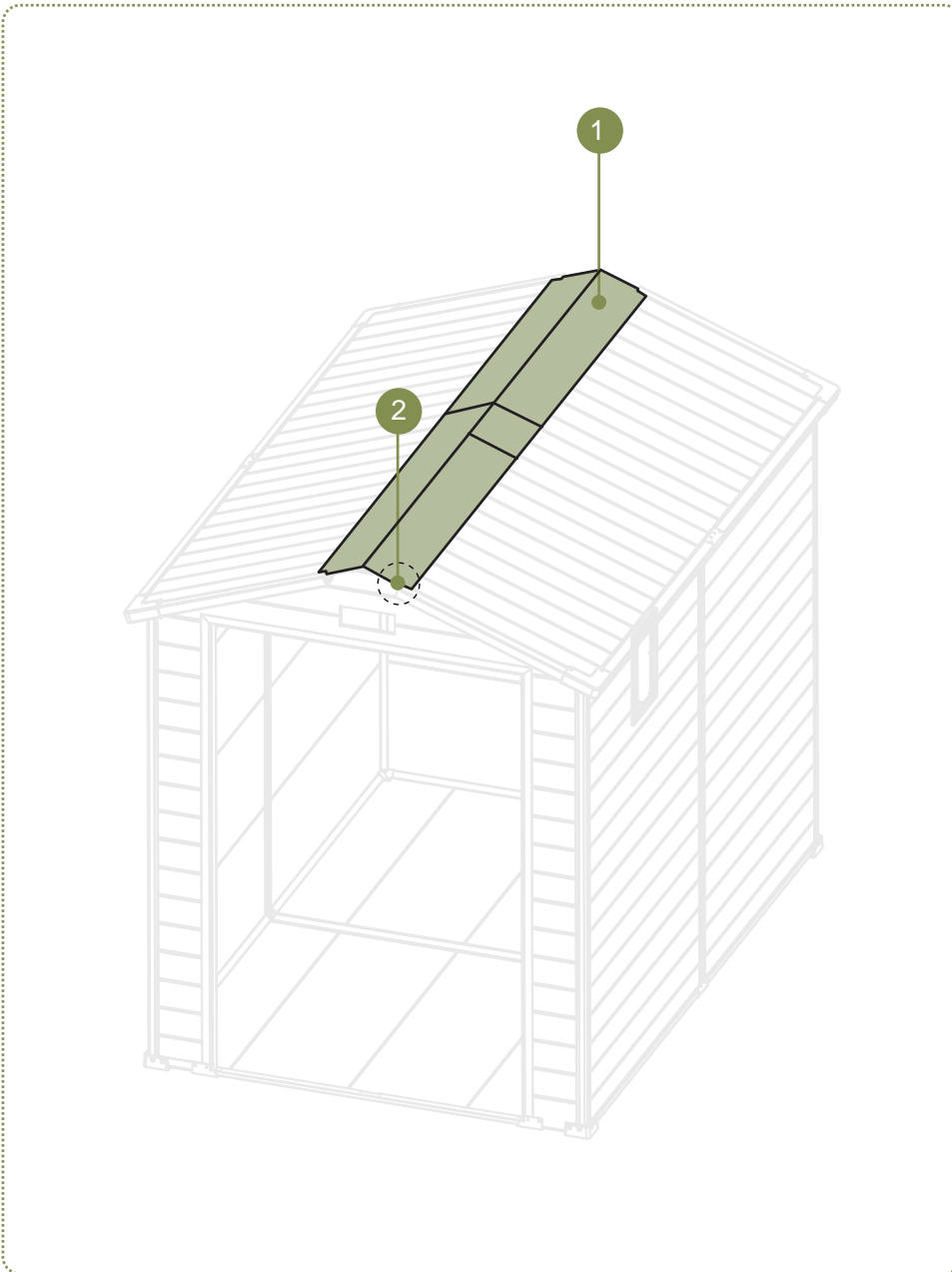

1. Please peel off the film before installation.

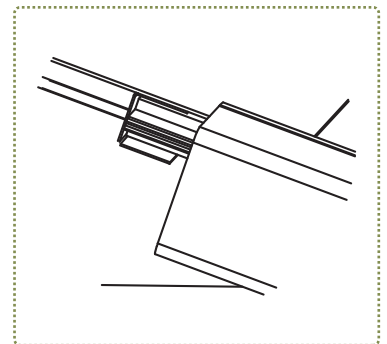

2. Install as Shown in the Diagram

List:

1 PC2

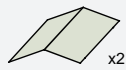

STEP 22 PC2 & Roof Installation

1. Safely get onto the roof using a ladder. Drill through the skylight panel where the holes are marked and secure it firmly.

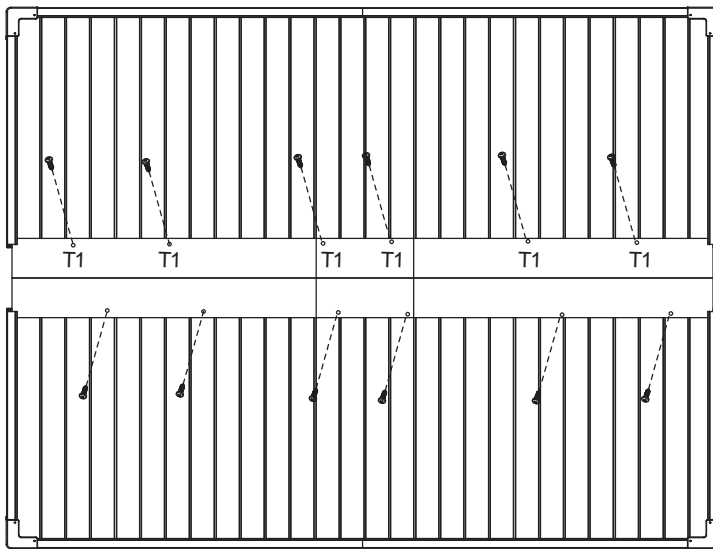

List:

1 T1



STEP 23 Install J11 & GF

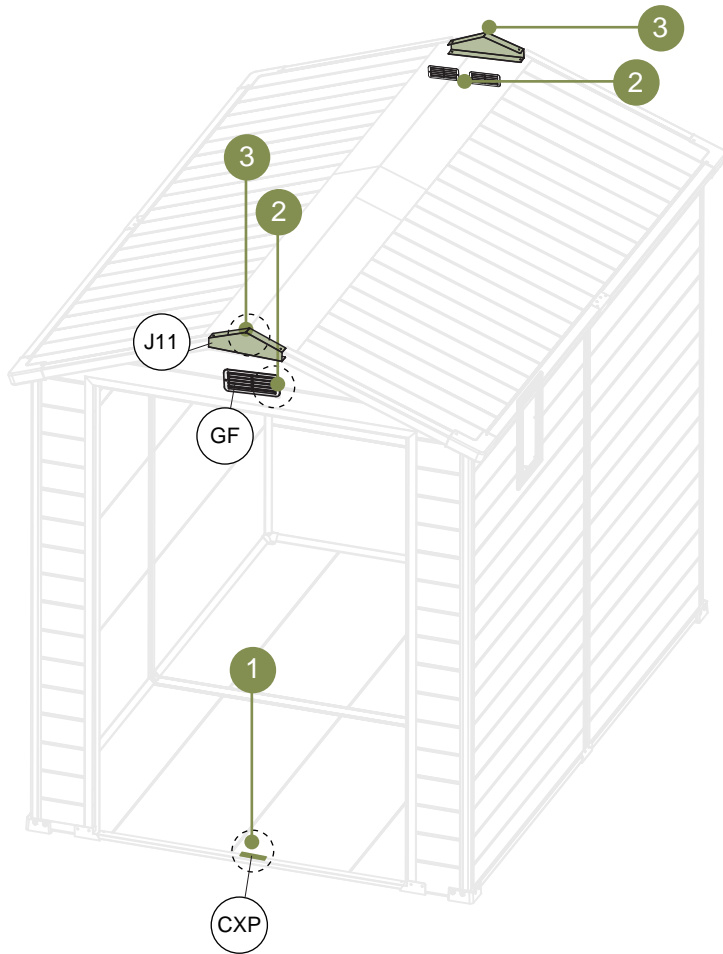

Tip: Repeat steps 2 and 3 on the corresponding parts on the opposite side.

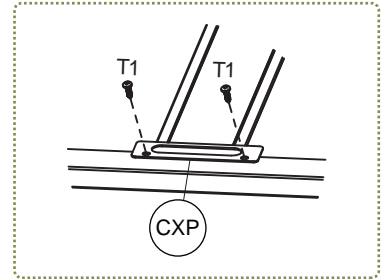

1. Screw in according to the positions shown in the diagram.

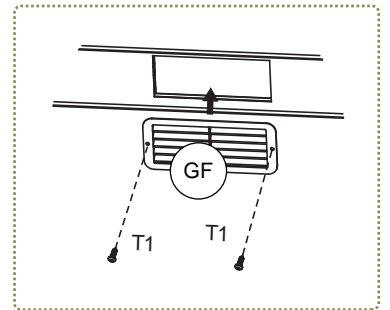



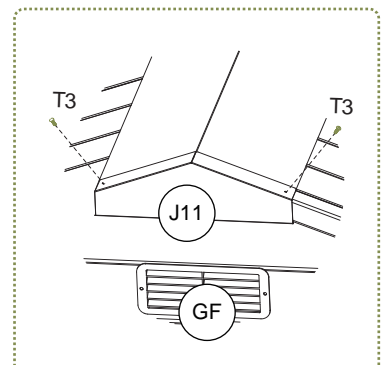

2. Screw in according to the positions shown in the diagram.



3. Screw in according to the positions shown in the diagram.

List:

- | | | | |
|-------|--|------|---|
| 1 CXP |  x1 | 5 T3 |  x8 |
| 2 GF |  x3 | | |
| 3 J11 |  x2 | | |
| 4 T1 |  x8 | | |

STEP 24 Install the Door Assembly

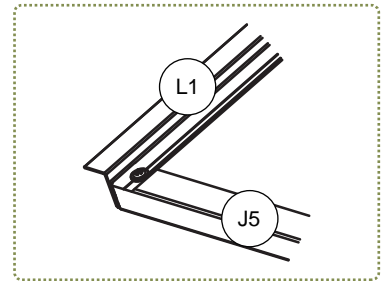
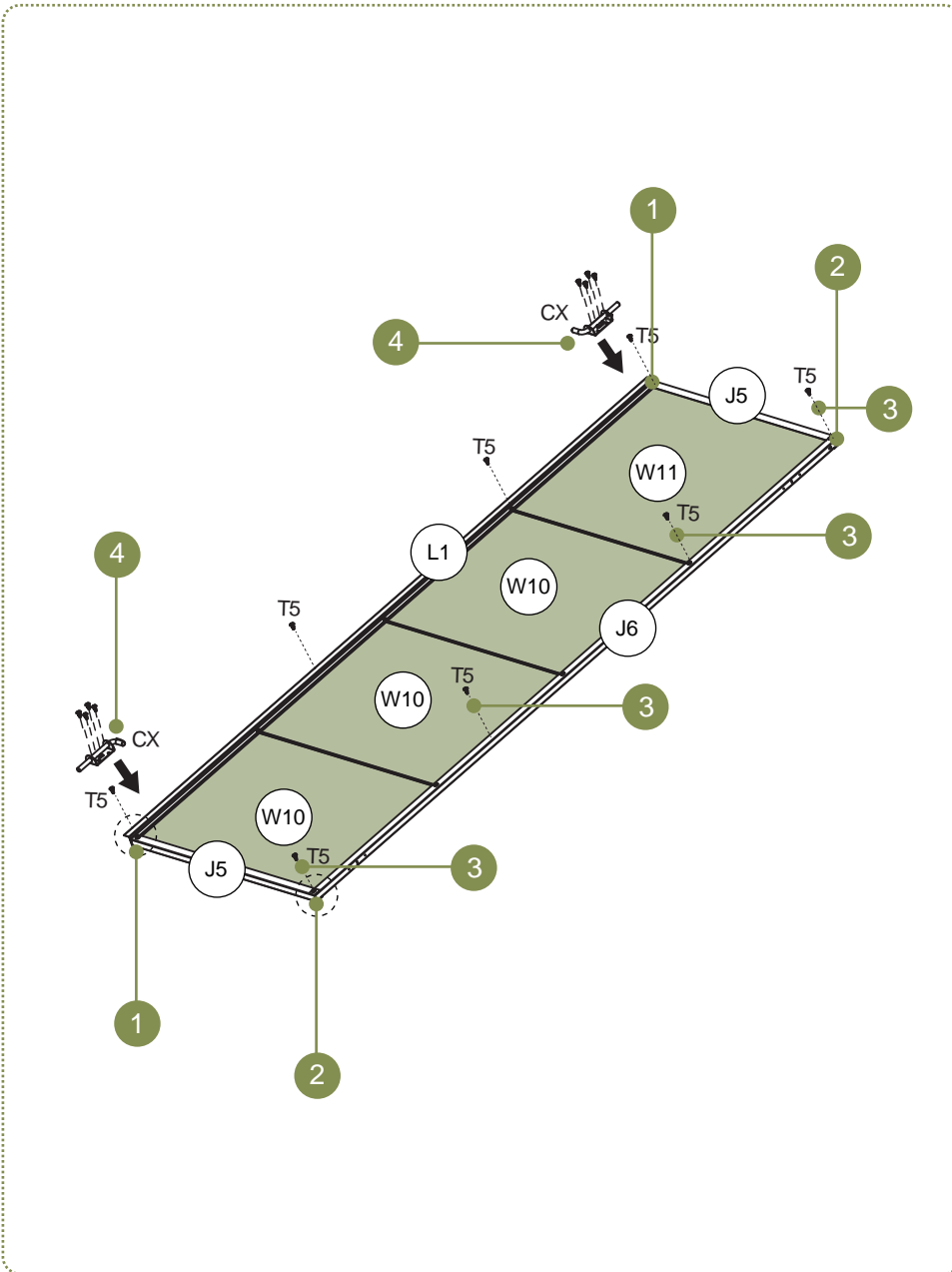

1. Note: When installing the left and right door panels, ensure that W11 is on top and L1 is on the left side of the right door panel.

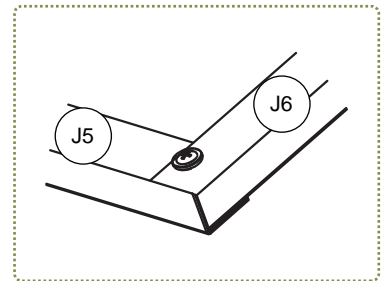

2. Note: When installing the left and right door panels, ensure that W11 is on top and L1 is on the left side of the right door panel.

3. Screw in according to the positions shown in the diagram.

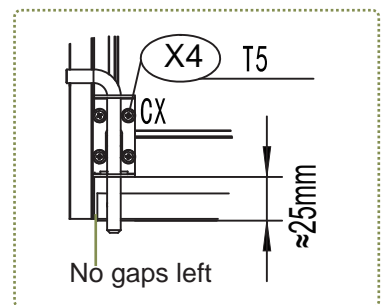

4. Screw in according to the positions shown in the diagram.

When installing the door assembly, only tighten the screws on the inner side.

List:

1 L1



x1

2 J5

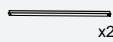

x2

3 J6

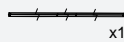

x1

4 CX

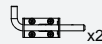

x2

5 T5



x16

6 W10



x3

7 W11



x1

STEP 25 Install the Door Assembly

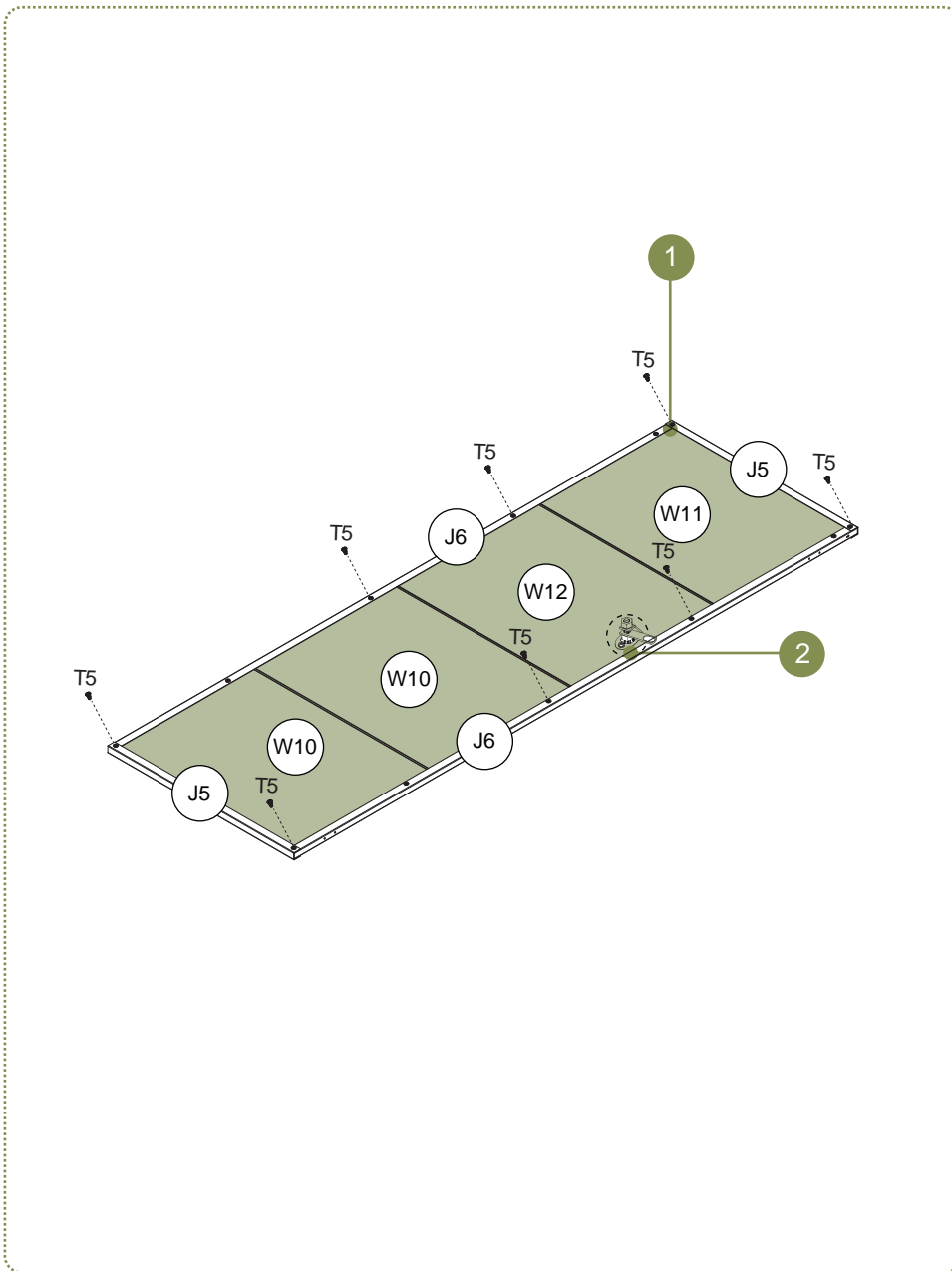

1. Repeat Step 24 to assemble the other half of the door. Please note that some part numbers may differ; install the parts according to the diagram.

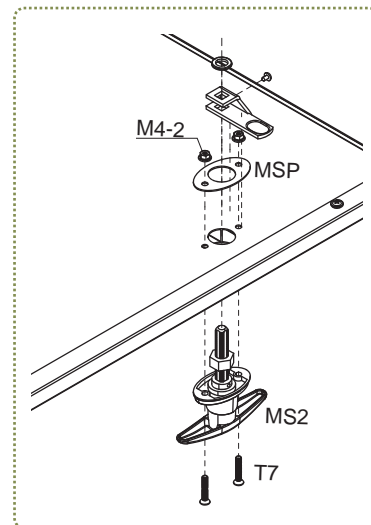

2. Install MS2 in the given order. After completing Step 24 (door lock installation), adjust the latch distance to ensure the latch holds the door tightly when closed.

When installing the door assembly, only tighten the screws on the inner side.

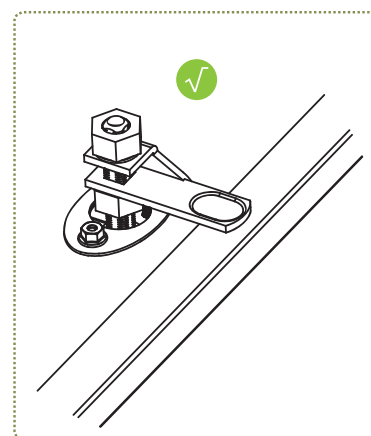

The door lock is shown installed as illustrated.

List:

1 W10



x2

2 W11



x1

3 W12



x1

4 J5

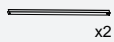

x2

5 J6



x2

6 MS2



x1

7 M4-2



x2

8 MSP



x1

9 T7



x2

10 T5



x8

STEP 26 Install the Door Assembly & JL1

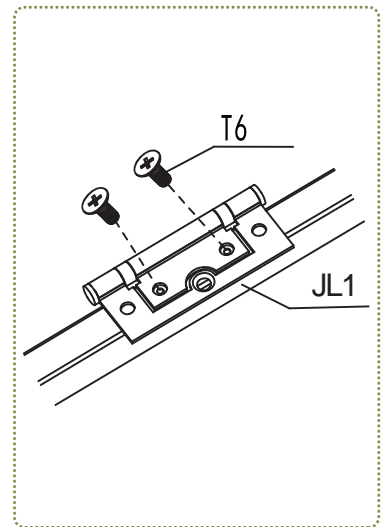
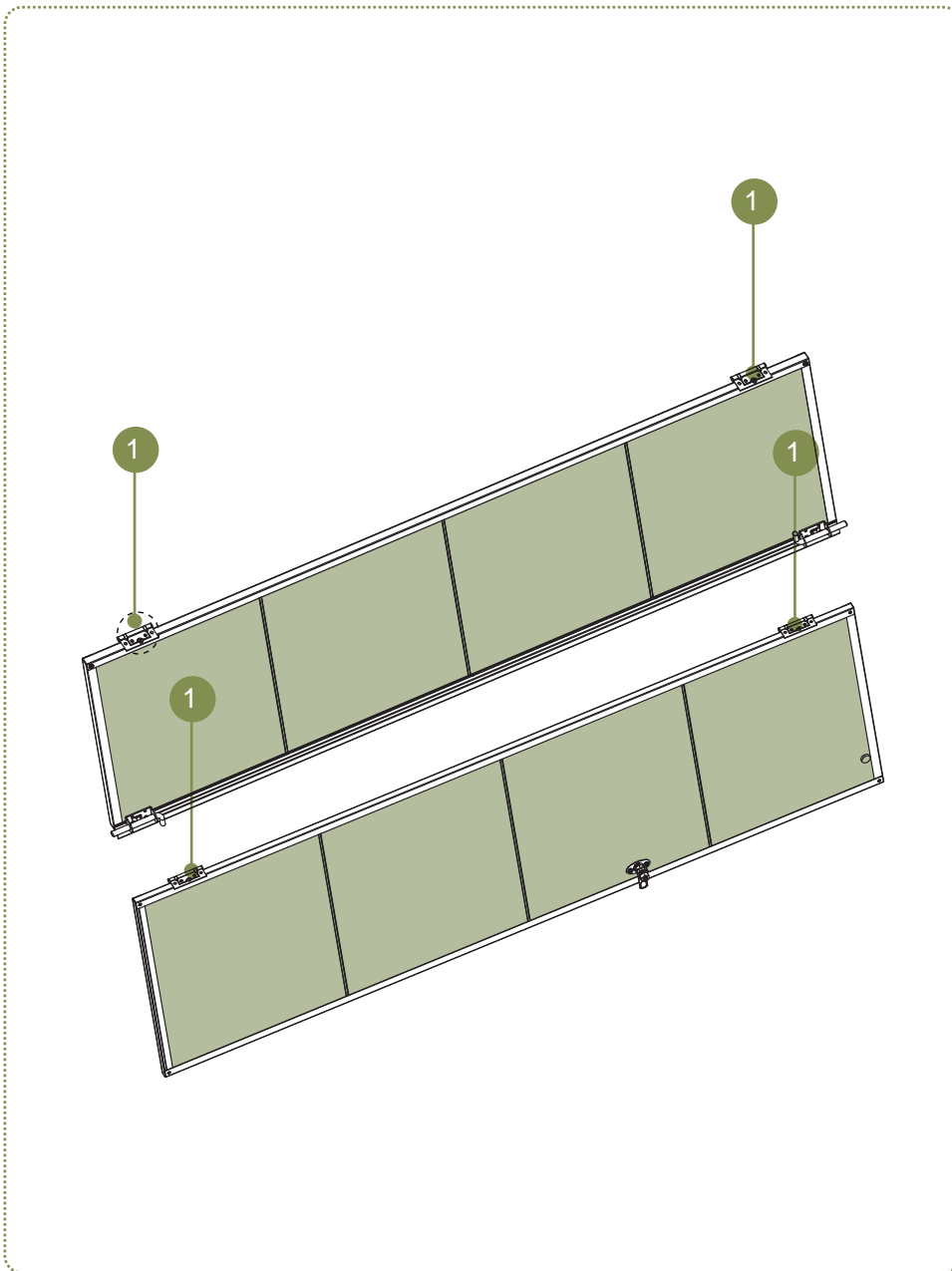

1. Insert the screws into the designated holes at a steady, slow speed until resistance is felt. Do not over-tighten to avoid stripping the threads.

List:

1 JL1



x4

2 T6



x8

STEP 27 Install the Door Assembly

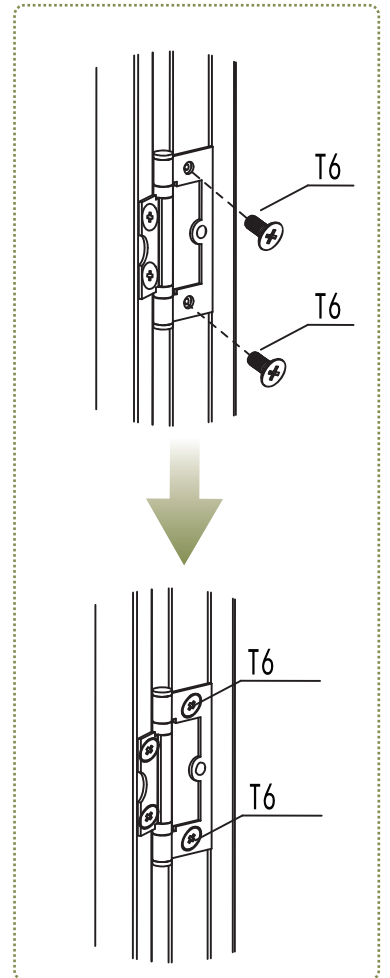
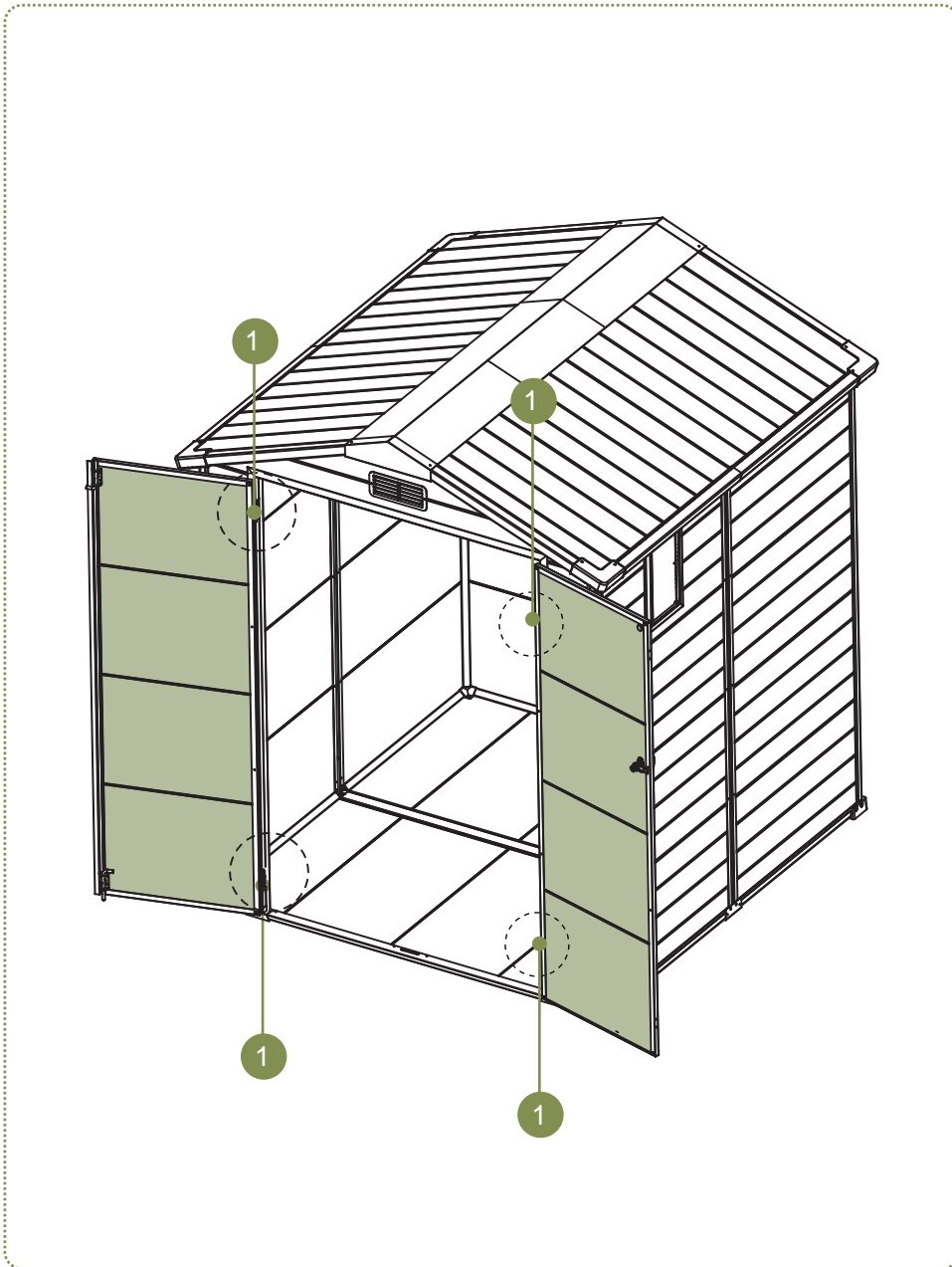

1. Insert the screws into the designated holes at a steady, slow speed until resistance is felt. Do not over-tighten to avoid stripping the threads.

List:

1 T6



STEP 28 Install Bottom Corner Components

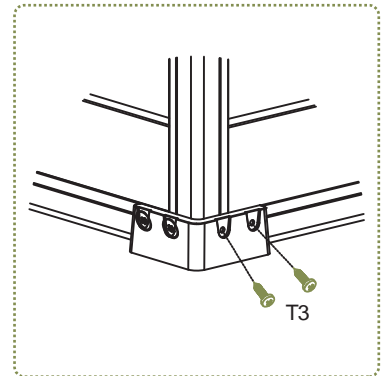
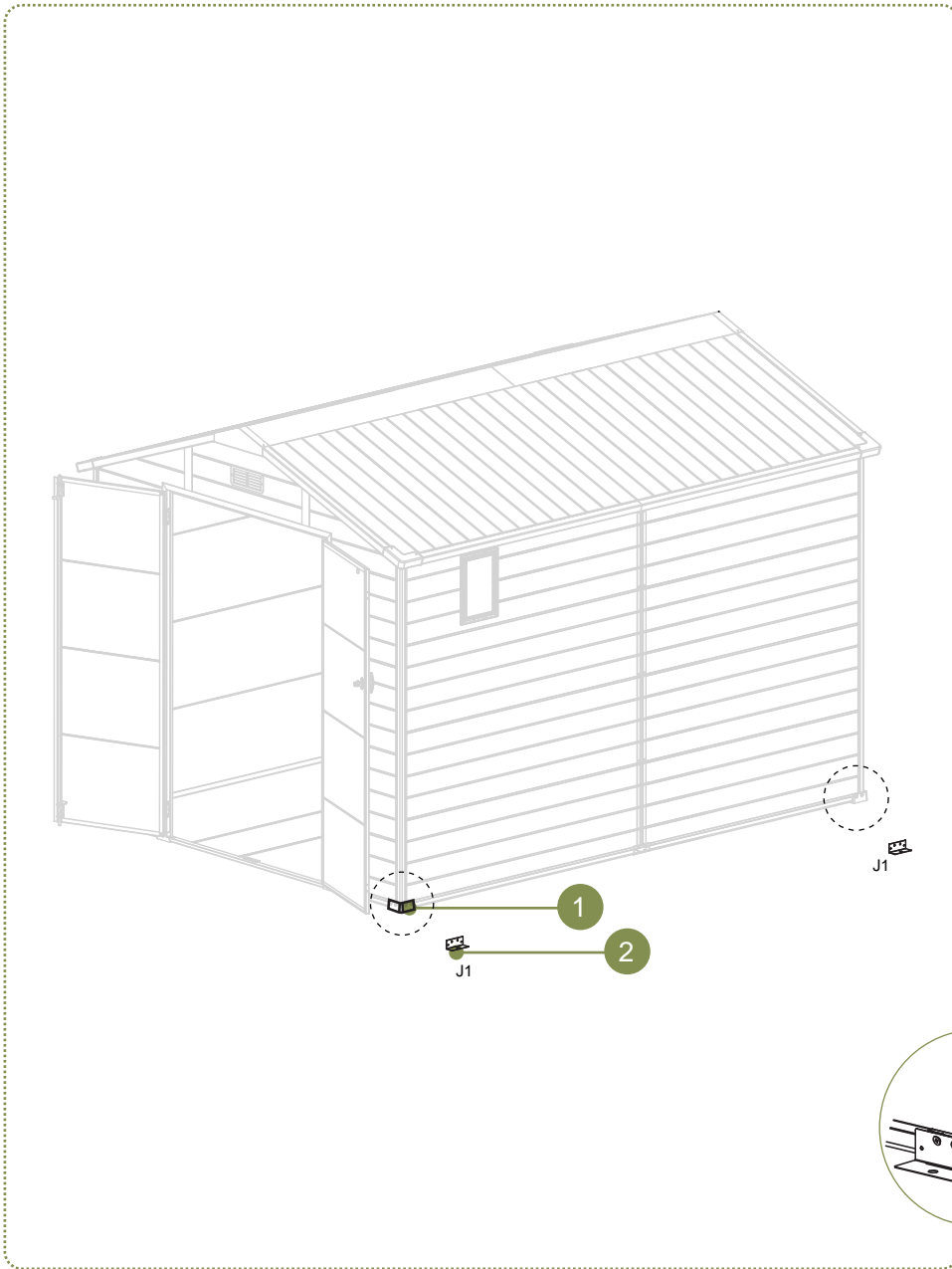

1. Remove the screws

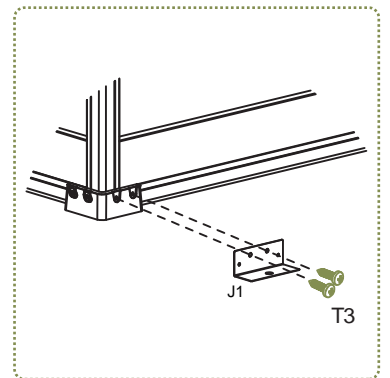

2. Tighten the screws after installing J1.

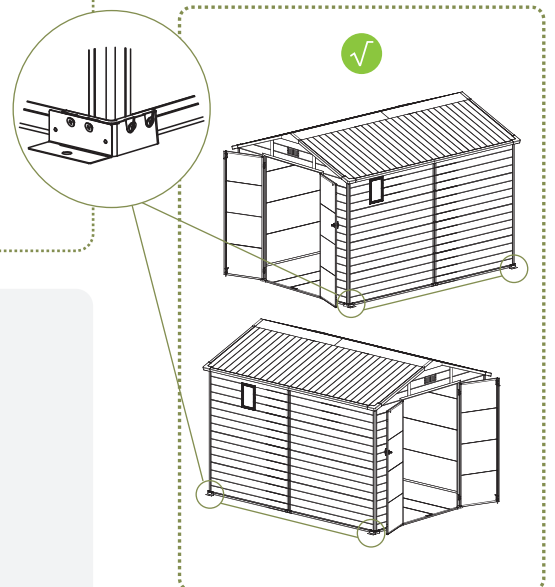

Installation completed

List:

1 J1

x4

2 T3

x8

STEP 29 Ground Nail Installation

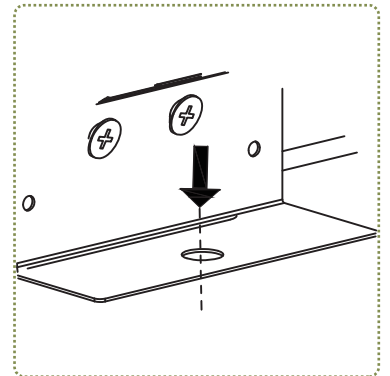
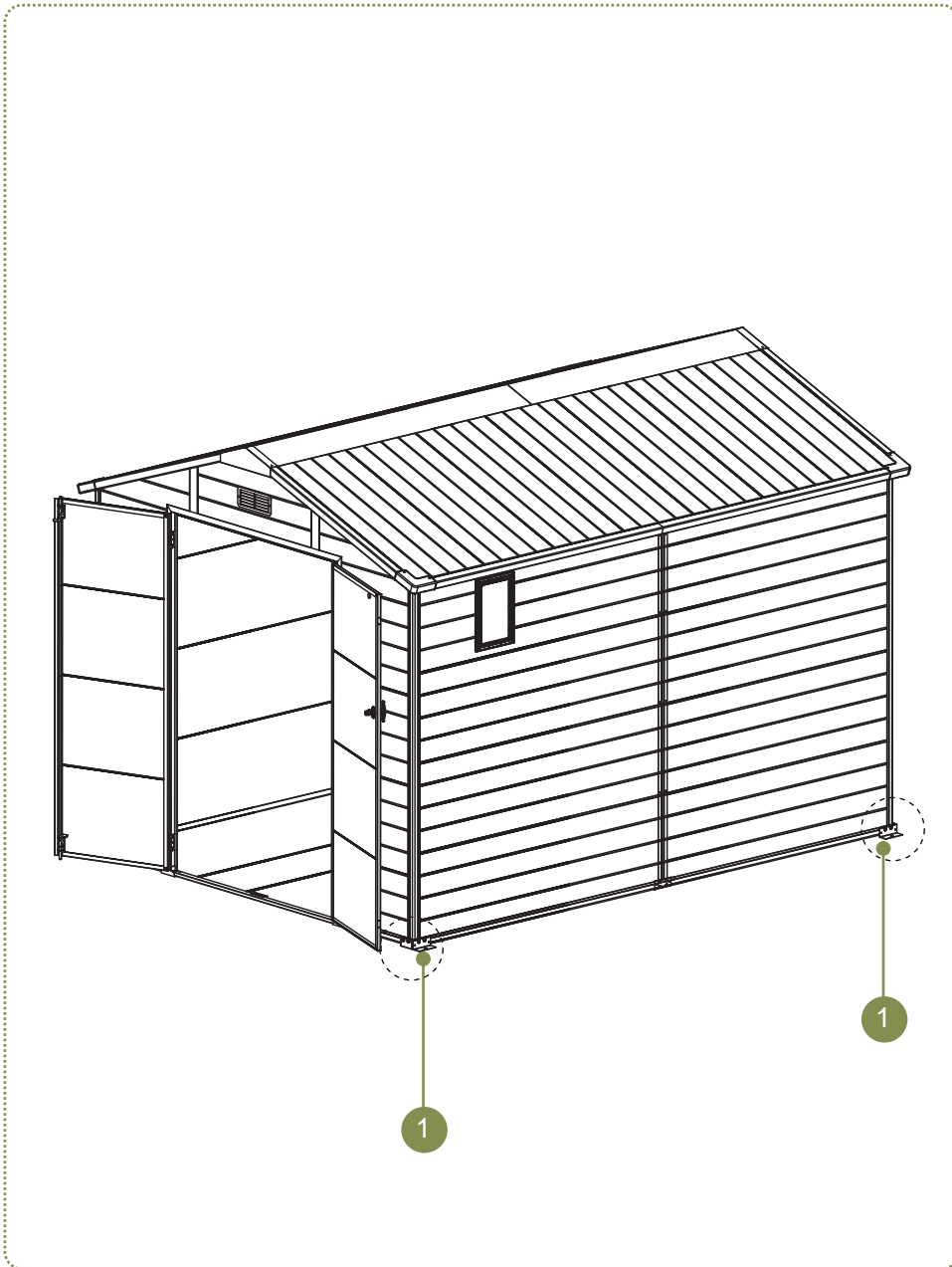

1. Ground fixed installation hole

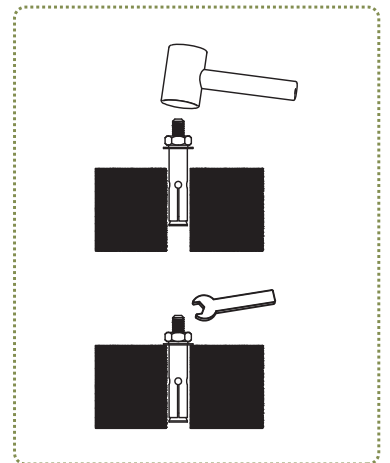

A. Cement floor or hard ground

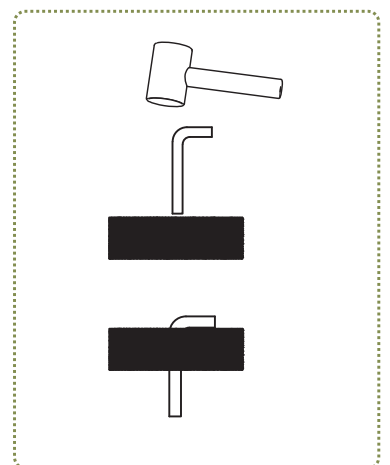

B. Grassland or soft ground

List:

1 PZ

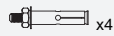

x4

2 PZ1



x4