







# ASSEMBLY INSTRUCTION

PART LIST		
1	DRESSER	1PC
2	MIRROR	1PC
3	MIRROR SUPPORT	2PCS
4	BUN FOOT	4PCS
5	SUPPORT LEG	1PC

ANTI-TIPPING HARDWARE PACK IN-5			
A		BRACKET	2PCS
B		TIE WRAP	1PC
C		SCREW #8x2" L	1PC
D		SCREW #8x5/8" L	1PC

HARDWARE LIST IN-6			
E		BOLT 1/4"x1-1/2"	8PCS
F		SPRING WASHER 1/4"	8PCS
G		FLAT WASHER 1/4"	8PCS
H		ALLEN KEY 4MM	1PC

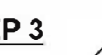
## STEP 1

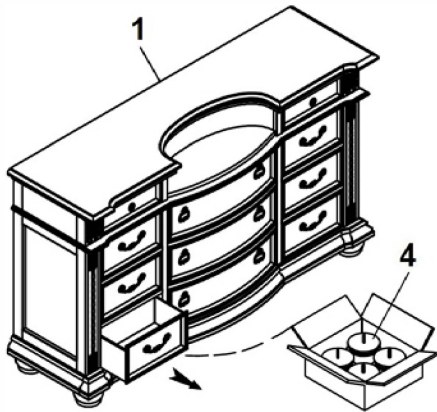

## STEP 2

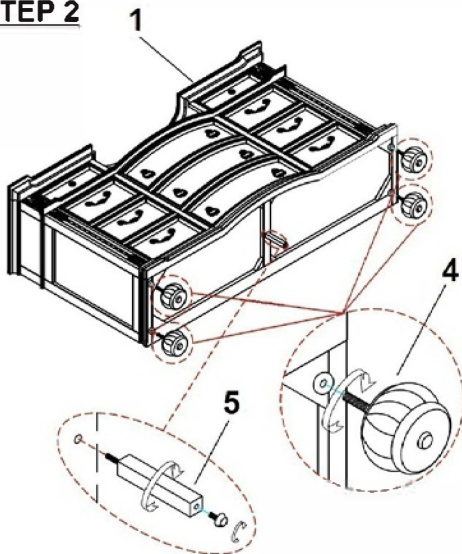

## STEP 3

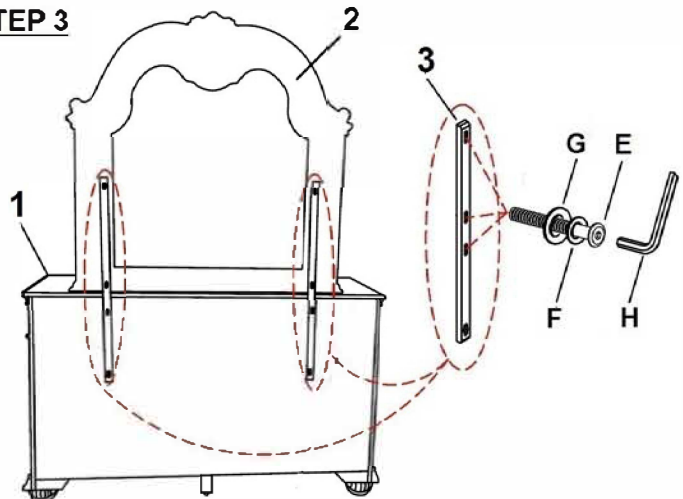

## STEP 4

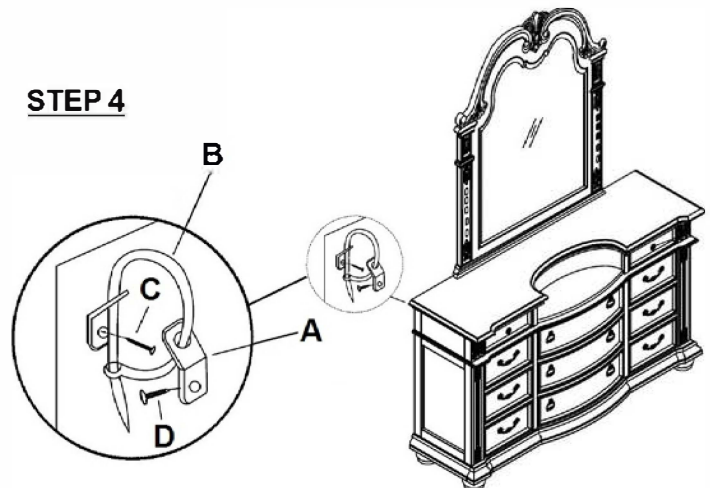

For item use on wooden floor, hard surfaces or carpets, it is recommended to Install protective pads under all legs and support to avoid/prevent from damages/scratches and discoloration.