

# ASSEMBLY INSTRUCTION

**W**e believe you will absolutely love your new furniture. Please immediately examine this product carefully. Any request for missing part or damage replacement must be received within 90 days of your receipt of the product. For some reason you want to return the product, please contact us directly before you decide to return your product to the retailer. Answer most concerns and can assist you with any questions you may have about your new product.

Have these ready when you email:

- Item Number
- PO #
- Purchaser Name
- Proof of Purchase
- Description of the problem and/or the Part Number needed

Replacements for missing or damaged parts or hardware are normally shipped within 3 to 5 business days and we thank you for your patient.

The item must be returned in good condition, in original box, with all original proof of purchase, parts and accessories, within the time frame specified by the retailer it was purchased from.

## 90-Day Limited Warranty Statement for Manufacturing Defects

Please read this Limited Warranty carefully. To maintain your Warranty, you will need to comply with the conditions stated here.

This warranty is for manufacturing defects only and does not cover damages as a result of misuse.

1. Our products sold comply with the description contained in this Warranty. All parts and products are warranted 90-Day from the original date of delivery except: parts and products used for commercial, contract, rental trade, institutional, or any other non-residential purposes; parts and products that have not been maintained in accordance with the care recommendations provided; parts and products damaged resulting from the consumer's improper assembly; or parts and products that are damaged or defective due to normal wear and tear.









2. To exercise rights under this warranty, proper documentation, i.e., photography, purchase order number, manufacturer's bar code label, and or any other pertinent information upon request is required. We reserve the right to repair or replace the product within the warranty period based upon the documentation received as support of a claim for consideration. We will not replace or repair any product if improper maintenance, improper handling, or improper use caused the damage.

3. Cost of packaging and shipping to and from us is not covered by the warranty unless expressly arranged by us. This warranty does not extend to furniture that has been exchanged or replaced by us as settlement of an original claim of defective merchandise. This warranty does not extend to furniture that has been moved from delivery location on original purchase order.

We appreciate your business!

# ASSEMBLY INSTRUCTION

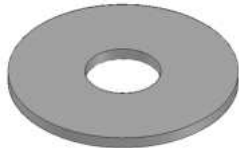
## HARDWARES LIST





ITEM	DESCRIPTION	DRAWING	QTY
A	JCBB SCREW M8 x 20MM		8 PCS
B	JCBB SCREW M8 x 30MM		8 PCS
C	JCBC SCREW M6 x 35MM		10 PCS
D	JCBC SCREW M6 x 40MM		10 PCS
E	SPRING WASHER M8 x 14MM		8 PCS
F	FLAT WASHER M8 x 22MM		8 PCS
G	SPRING WASHER M6 x 13MM		20 PCS
H	FLAT WASHER M6 x 19MM		20 PCS
I	M4 ALLEN KEY (65MM)		1 PC
J	M5 ALLEN KEY (65MM)		1 PC

# ASSEMBLY INSTRUCTION

## HARDWARES LIST

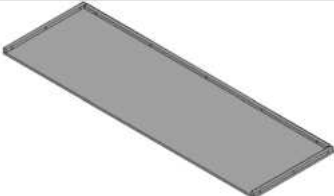
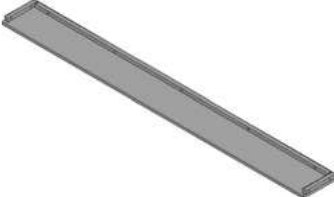
ITEM	DESCRIPTION	DRAWING	QTY
K	CSK C/B SCREW (M4 x 32MM)		8 PCS

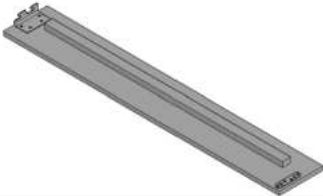
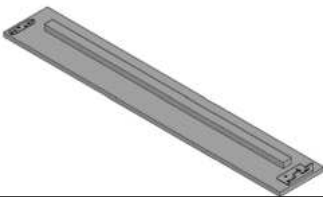
## PARTS LIST

ITEM	DESCRIPTION	DRAWING	QTY
1	HEADBOARD		1 PC
2	FOOTBOARD		1 PC
3	HEADBOARD AND FOOTBOARD TOP PANEL		2 PCS
4	HEADBOARD LEG (R)		1 PC
5	SIDE RAIL (i)		2 PCS
6	SIDE RAIL (ii)		2 PCS
7	HEADBOARD LEG (L)		1 PC
8	FOOTBOARD LEG (R)		1 PC

# ASSEMBLY INSTRUCTION

## PARTS LIST

ITEM	DESCRIPTION	DRAWING	QTY
9	FOOTBOARD LEG (L)		1 PC
10	SIDE RAIL SUPPORT LEG		2 PCS
11	SLAT		4 PCS
12	CENTER SUPPORT LEG		8 PCS

### ASSEMBLY TOOLS REQUIRED

**Screwdriver (not provide)**

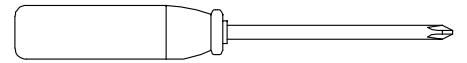

### STEP 1

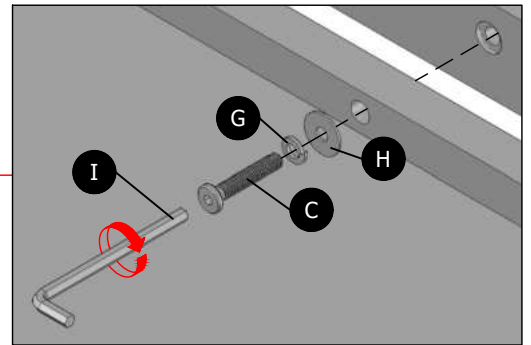
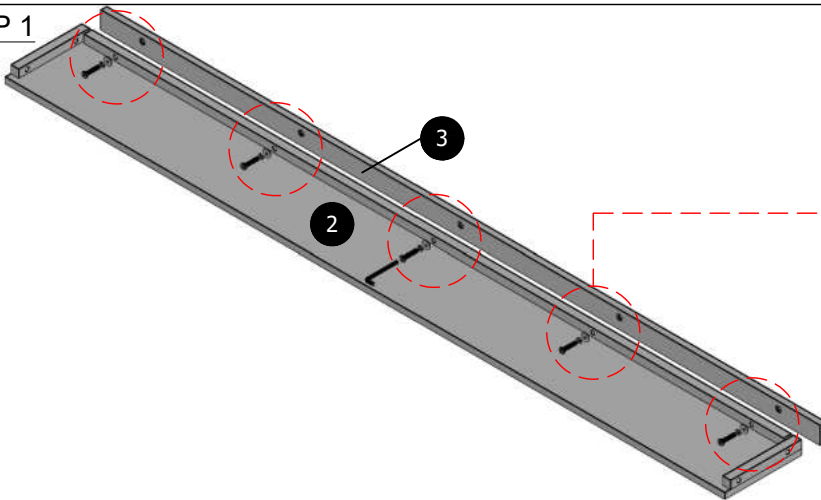

### STEP 2

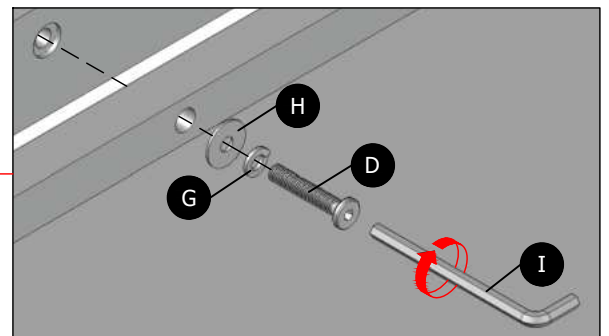
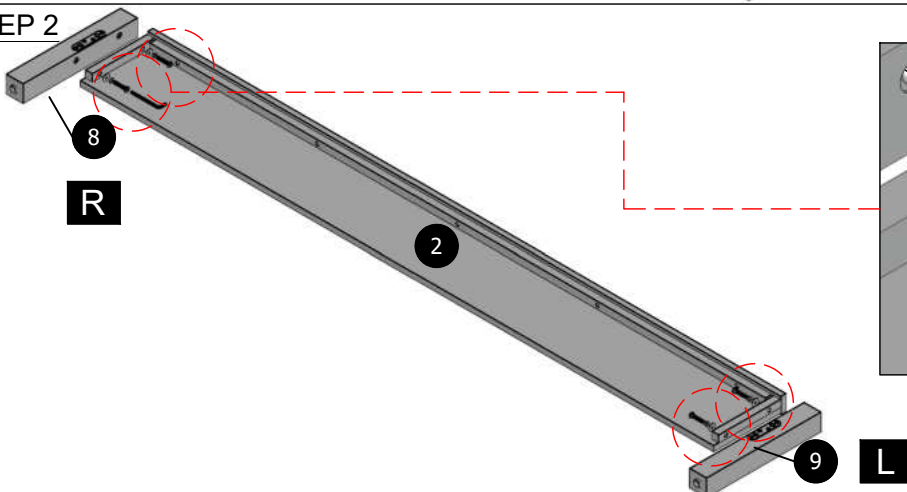

# ASSEMBLY INSTRUCTION

## STEP 3

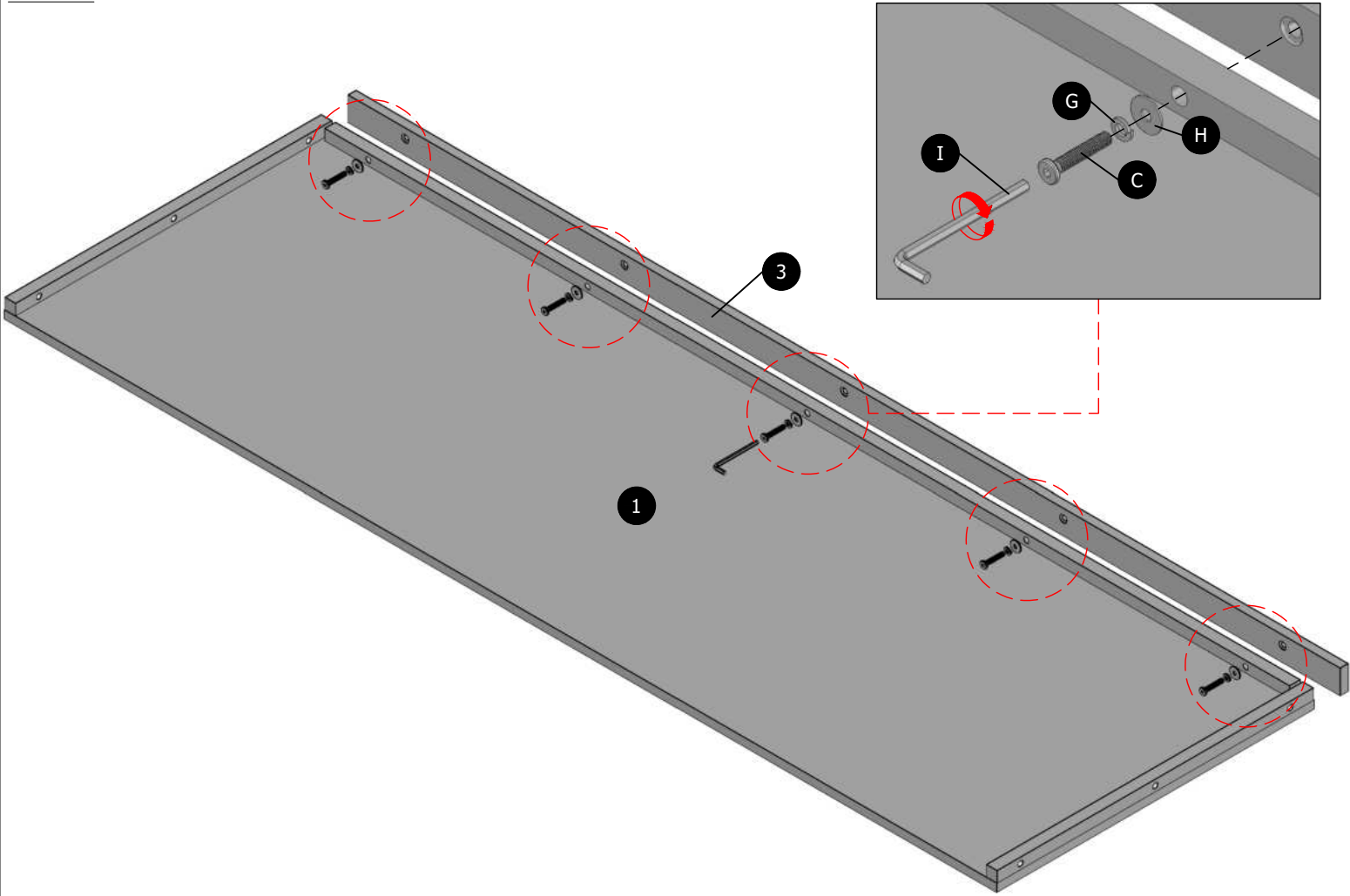

## STEP 4

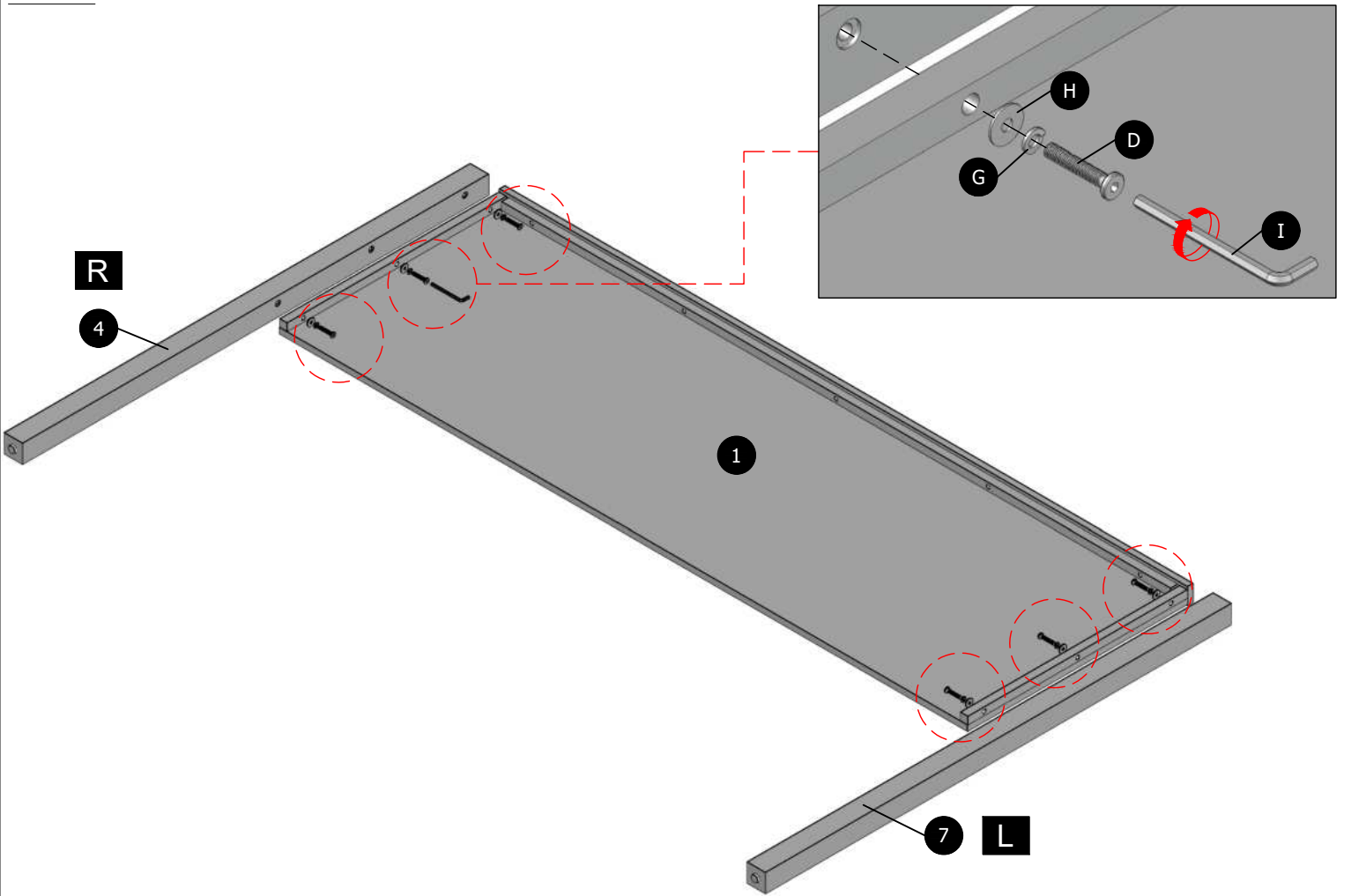

# ASSEMBLY INSTRUCTION

STEP 5

x 2

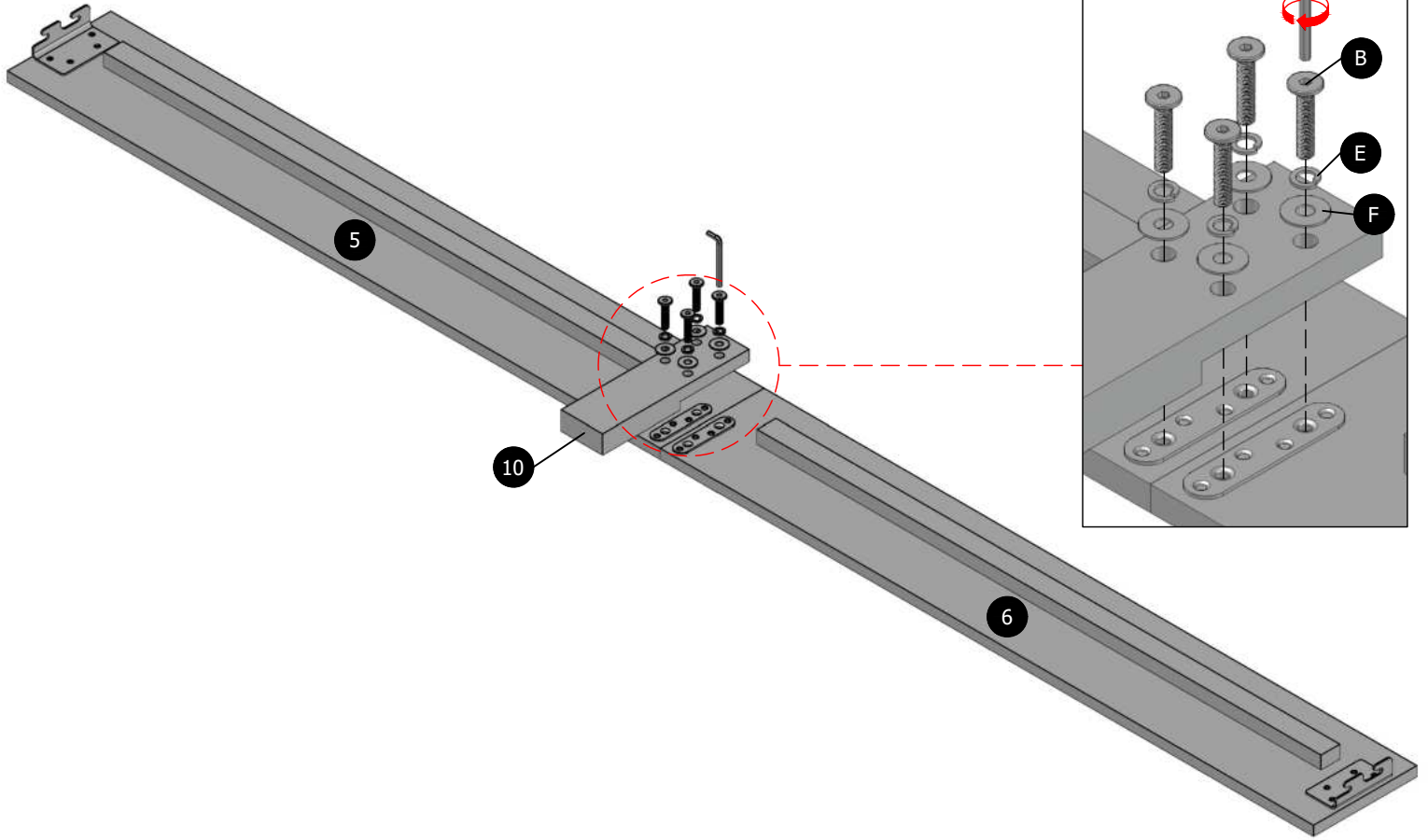

STEP 6

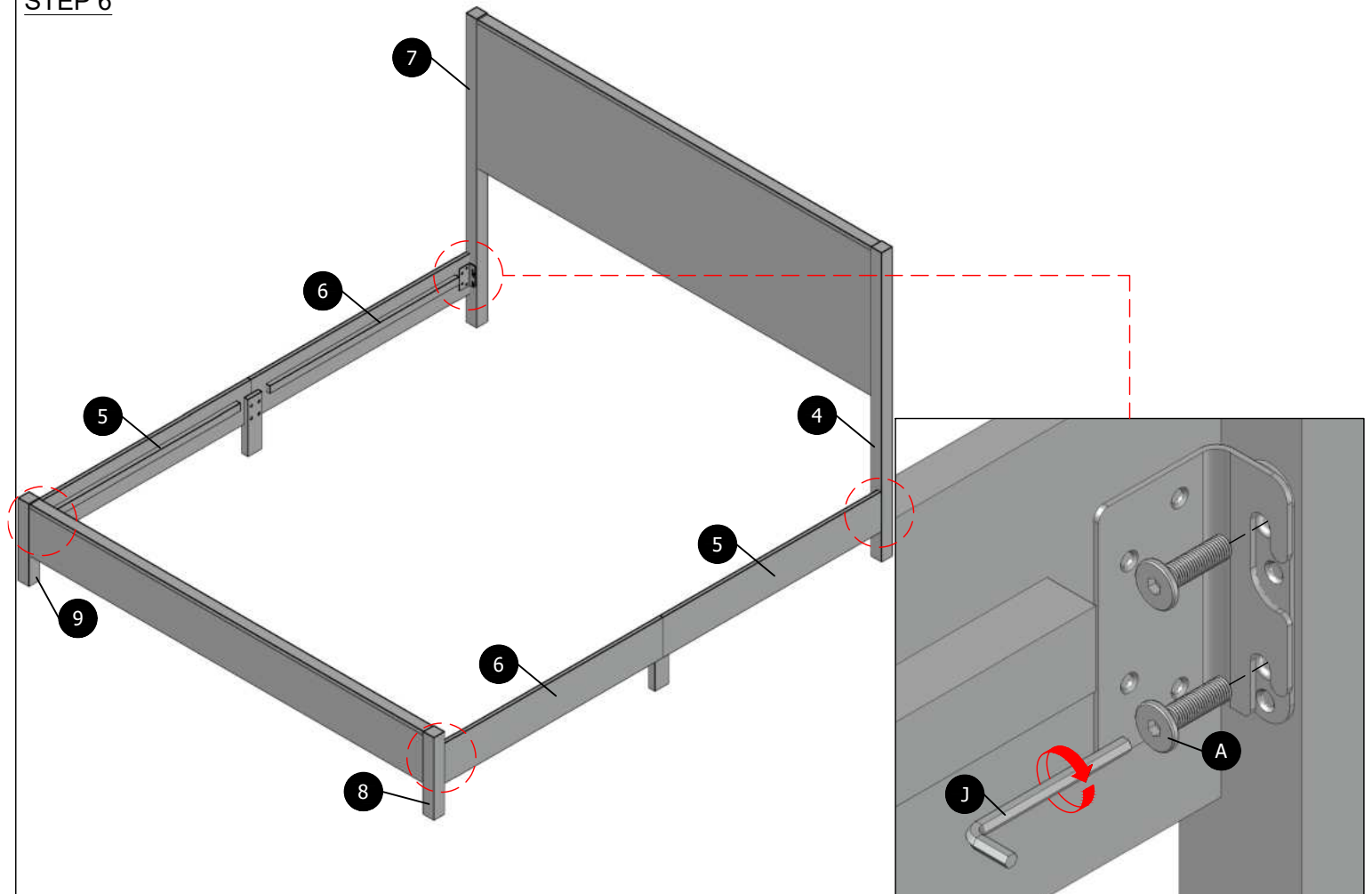

# ASSEMBLY INSTRUCTION

STEP 7

x 4

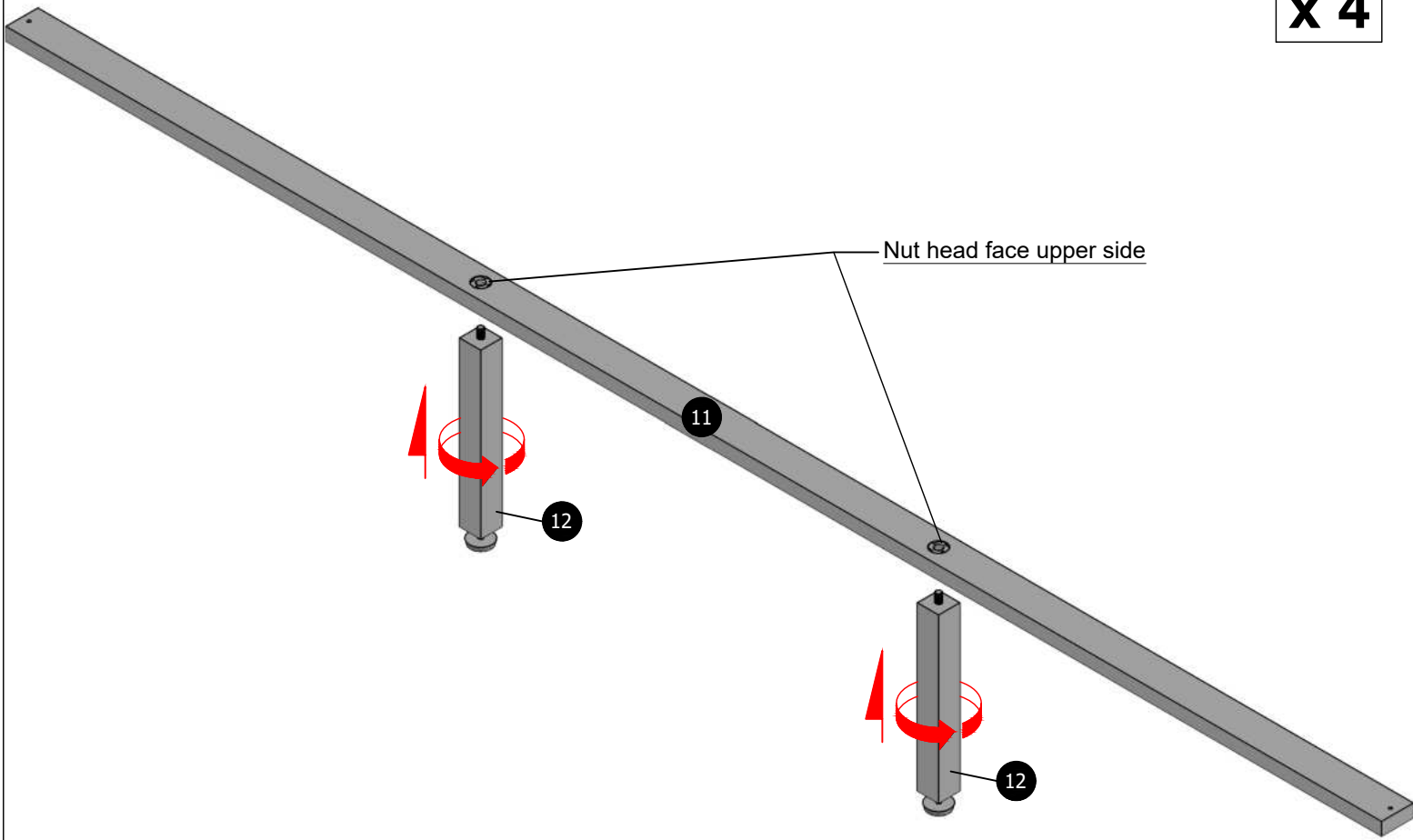

STEP 8

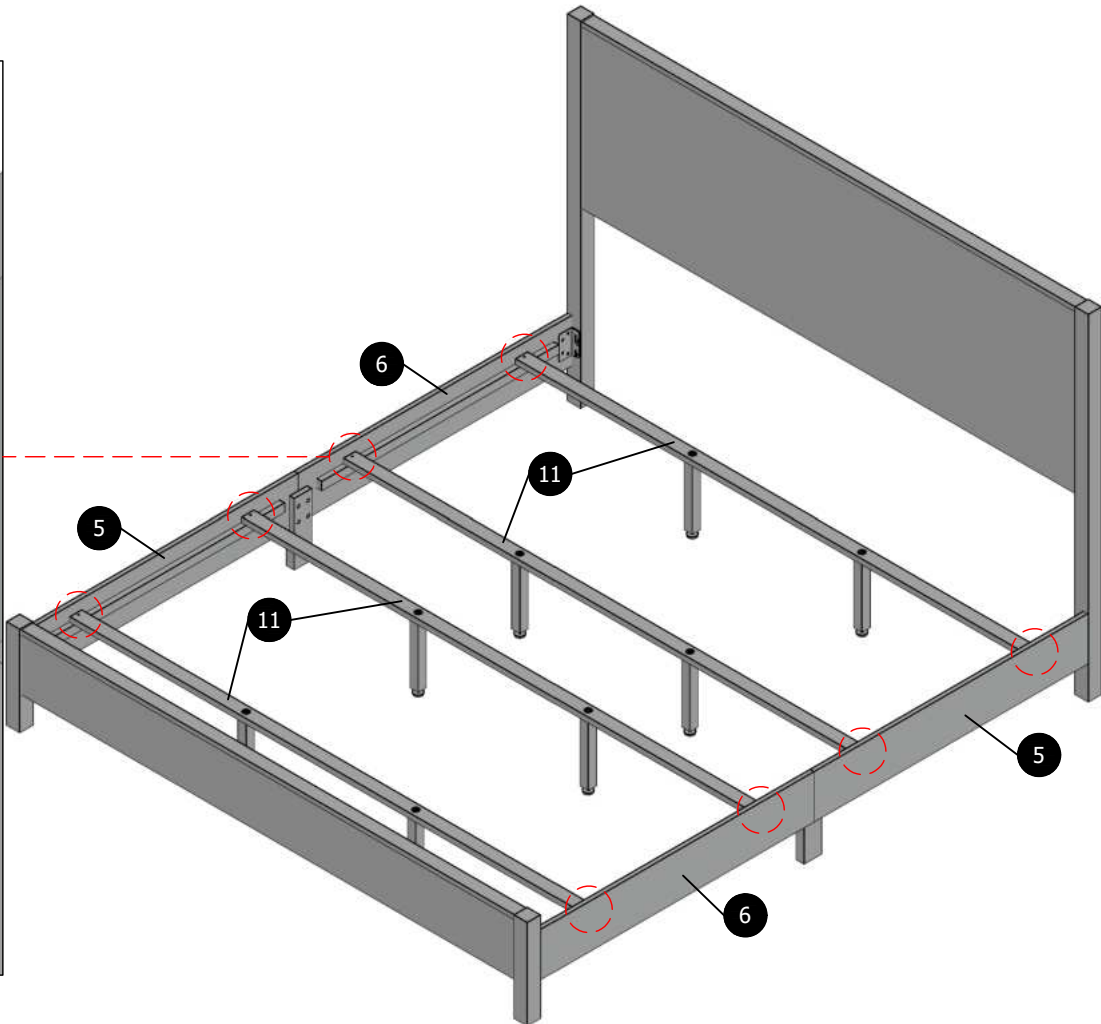
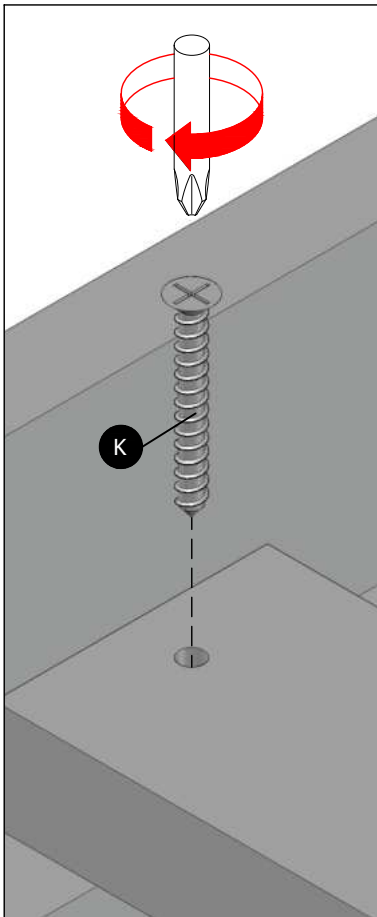

# ASSEMBLY INSTRUCTION

STEP 9

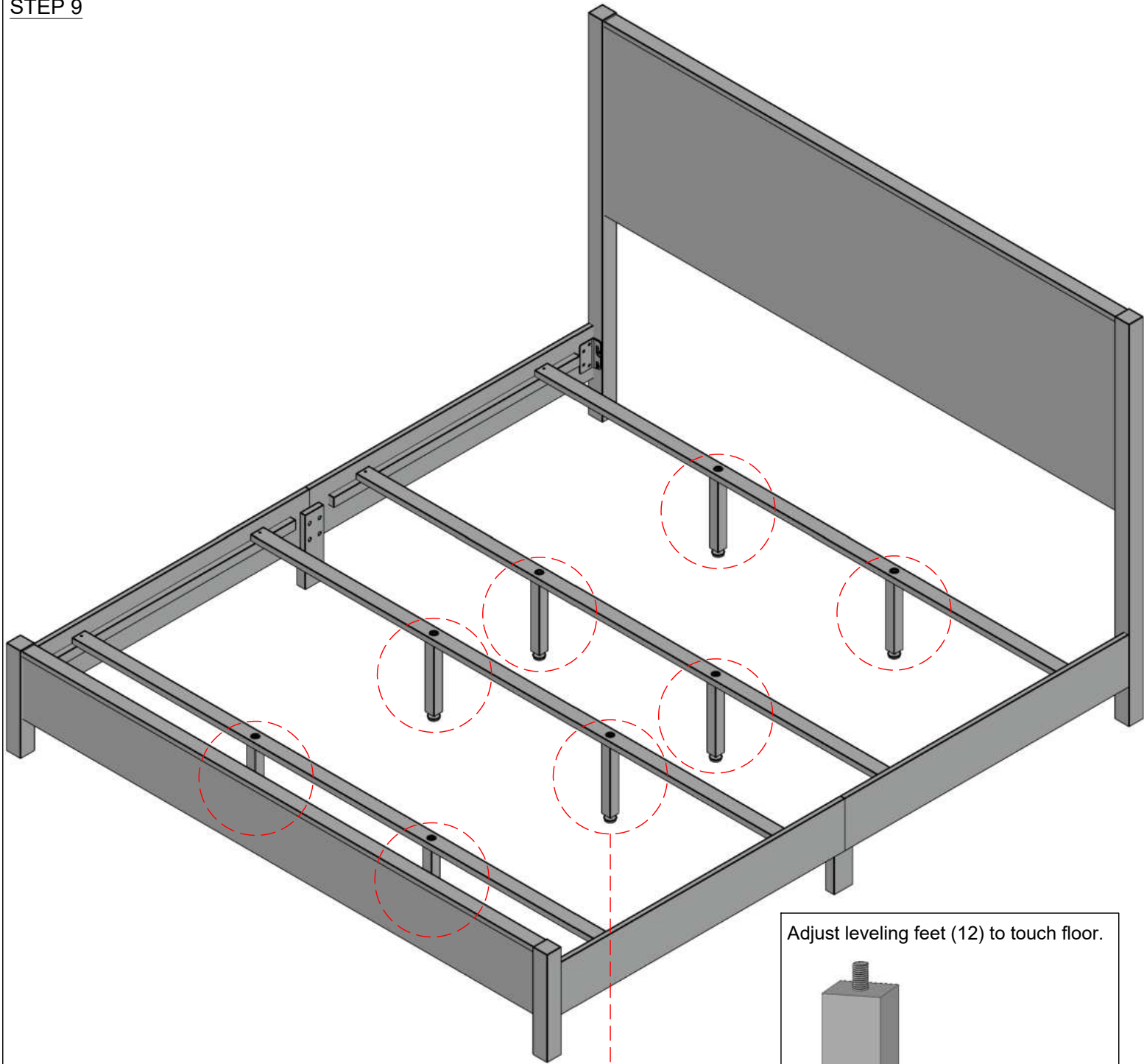

Adjust leveling feet (12) to touch floor.

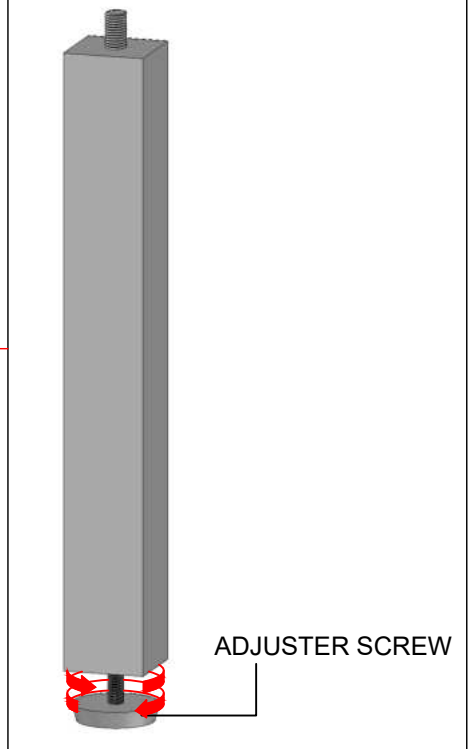

**ASSEMBLY COMPLETED**