

ASSEMBLY INSTRUCTION

PATIO RATTAN SOFA SET

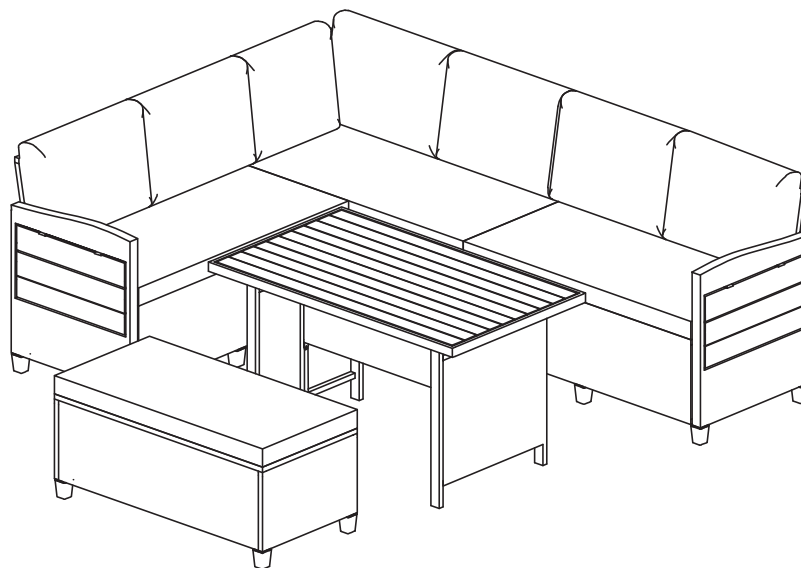

Notice:

- 1. 50% Tighten before fixing all screws, Allen wrench is recommended instead of an electric drill.**
- 2. Place the item on a flat ground to adjust and make sure it remains stable.**
- 3. Tighten up all screws with tools gradually.**
- 4. If the screws are not aligned with holes during assembly, please loosen all the other screws to 50% and continue the assembly process.**
- 5. If the item is not stable, please loosen all the screws, adjust it on a flat ground and tighten up all screws again.**
- 6. Note: If one or some screws are fully tightened during assembly, chances are the others will not be aligned with holes. In addition, all the holes are designed to be relatively larger to provide more space for the adjustment of the screws.**

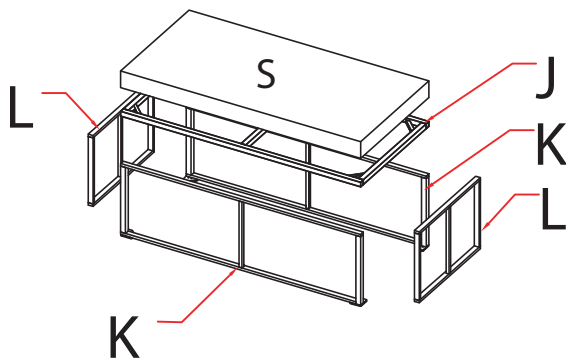
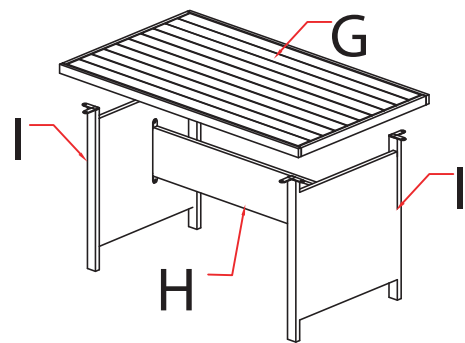
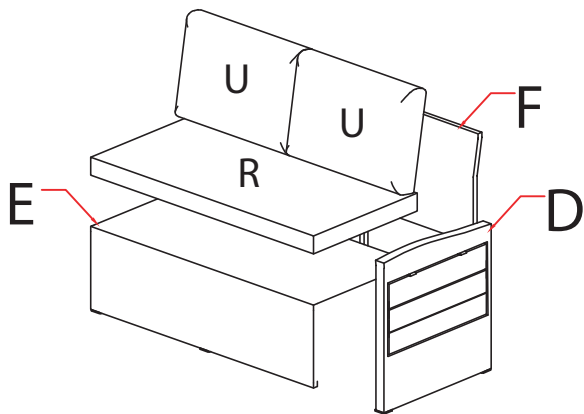
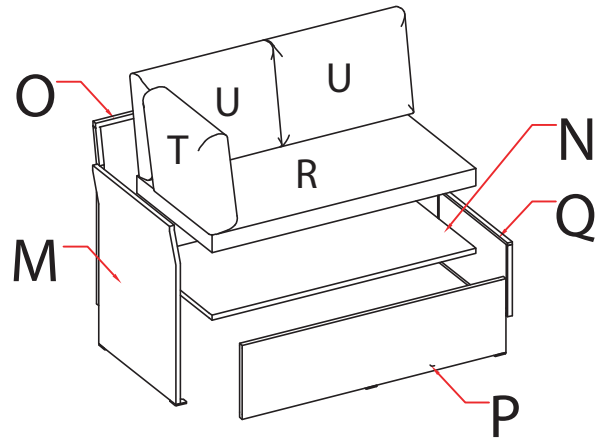
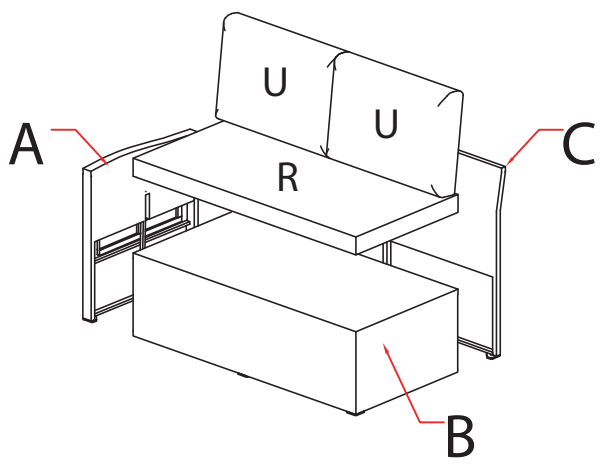

BOX 1/3:

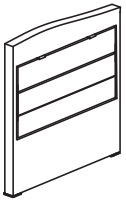

D x1

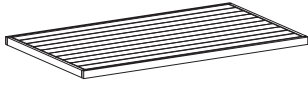

G x1

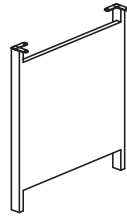

I x2



J x1



K x2



L x2

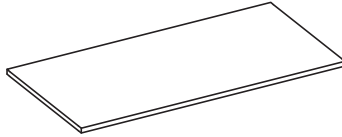

N x1

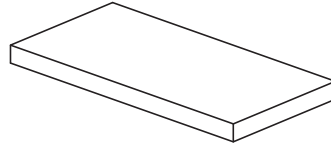

R x1



Hardware

BOX 2/3:

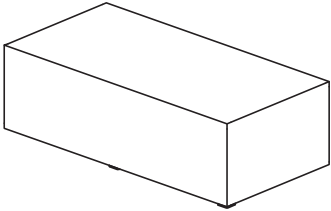

B x1

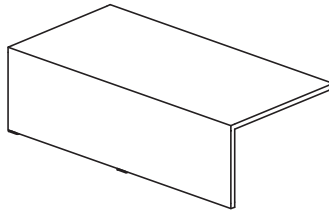

E x1



H x1

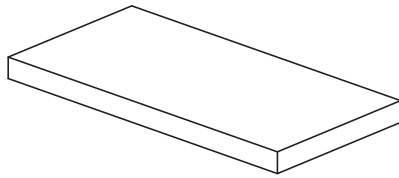

R x2

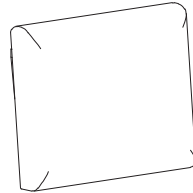

U x4

BOX 3/3:

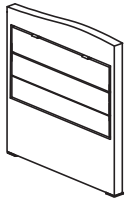

A x1

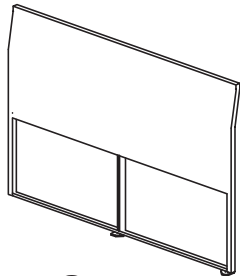

C x1

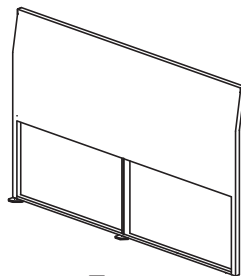

F x1

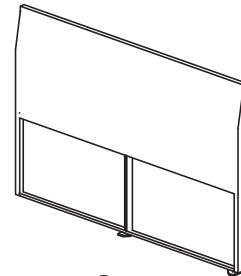

O x1

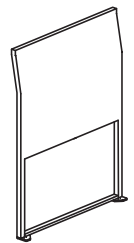

M x1

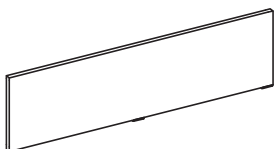

P x1

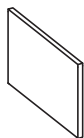

Q x1

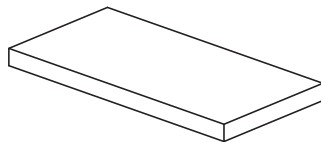

S x1

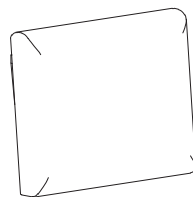



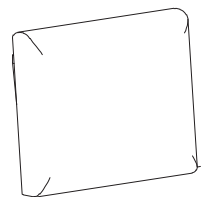

T x1

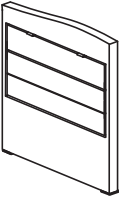
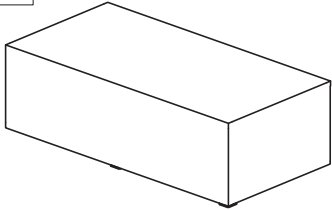
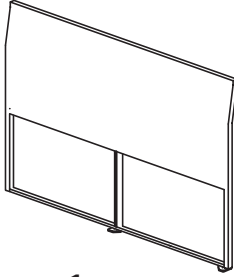
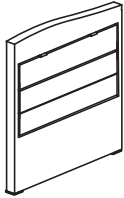
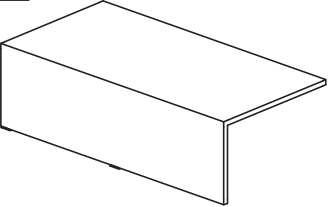
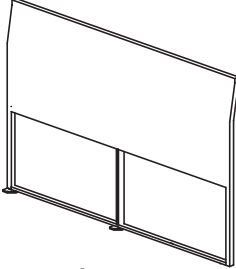
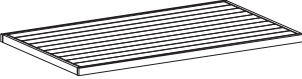
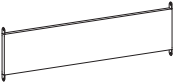
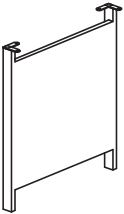

U x2

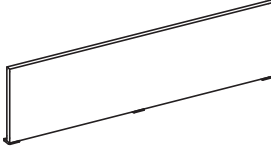
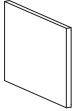
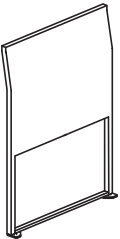
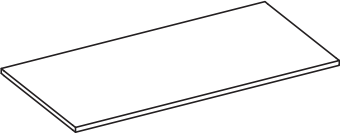
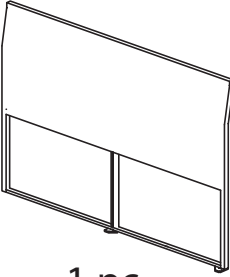
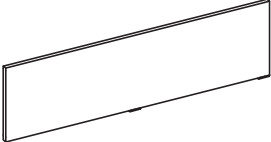
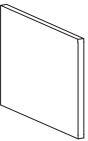
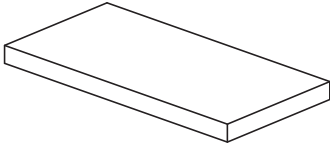
Part list & Hardware

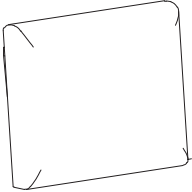
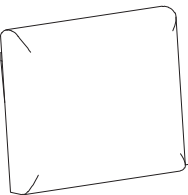
<p>A</p>  <p>1 pc</p>	<p>B</p>  <p>1 pc</p>	<p>C</p>  <p>1 pc</p>	<p>D</p>  <p>1 pc</p>
<p>E</p>  <p>1 pc</p>	<p>F</p>  <p>1 pc</p>	<p>G</p>  <p>1 pc</p>	<p>H</p>  <p>1 pc</p>
<p>I</p>  <p>2 pcs</p>	<p>J</p>  <p>1 pc</p>	<p>K</p>  <p>2 pcs</p>	<p>L</p>  <p>2 pcs</p>
<p>M</p>  <p>1 pc</p>	<p>N</p>  <p>1 pc</p>	<p>O</p>  <p>1 pc</p>	<p>P</p>  <p>1 pc</p>
<p>Q</p>  <p>1 pc</p>	<p>R</p>  <p>3 pcs</p>	<p>S</p>  <p>1 pc</p>	<p>T</p>  <p>1 pc</p>
<p>U</p>  <p>6 pcs</p>			

Part list & Hardware

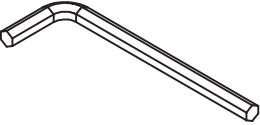
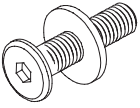
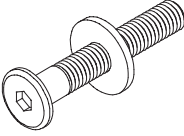
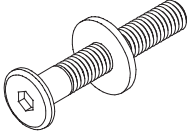
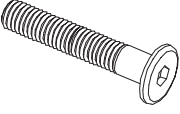
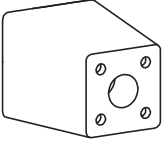
<p>1</p>  <p>Allen key (2 pcs)</p>	<p>2</p>  <p>Bolt x 20 mm (12 pcs)</p>	<p>3</p>  <p>Bolt x35 mm (44 pcs)</p>	<p>4</p>  <p>Bolt x65 mm (2 pcs)</p>
<p>5</p>  <p>Bolt x55 mm (24 pcs)</p>	<p>6</p>  <p>Plastic foot (24 pcs)</p>		

Step 1 (bench right assembly)

Connect the bench seat frame (B) & bench back frame (C), tighten allen bolts (3) with allen key (1)

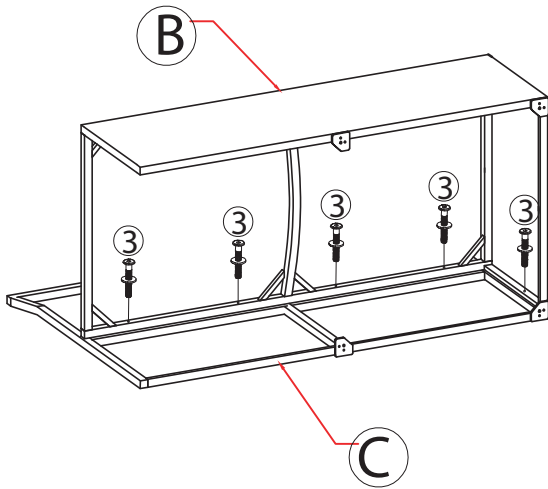

B x1 **C** x1 **3** x5

Step 2

Connect the part from step 1 & right arm frame (A), tighten allen bolts (3) with allen key (1)

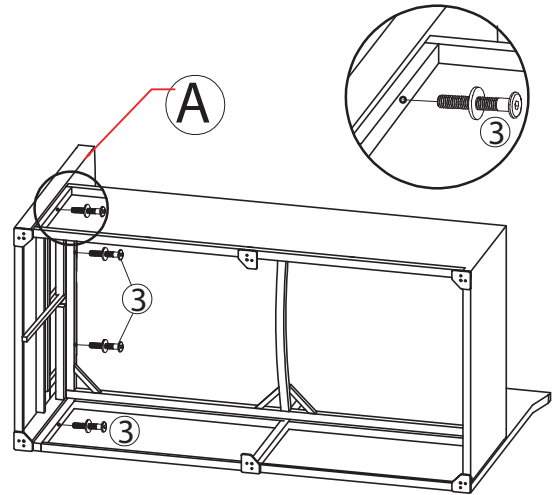

A x1 **3** x4

Step 3

Connect the part from step 2 & plastic foots (6), tighten allen bolts (5), (4) with allen key (1)

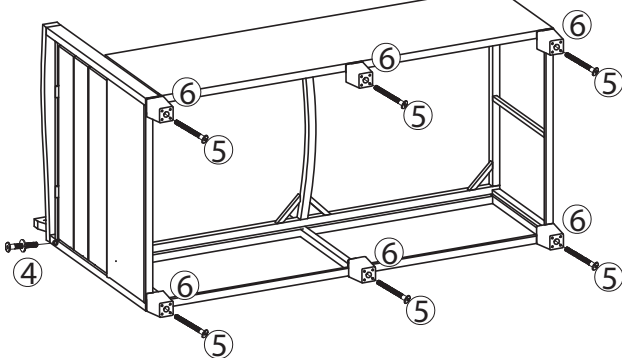

6 x6 **4** x1 **5** x6

Step 4

Put the bench upright and make sure all legs are level, then firmly tighten bolts with Allen Key (1)

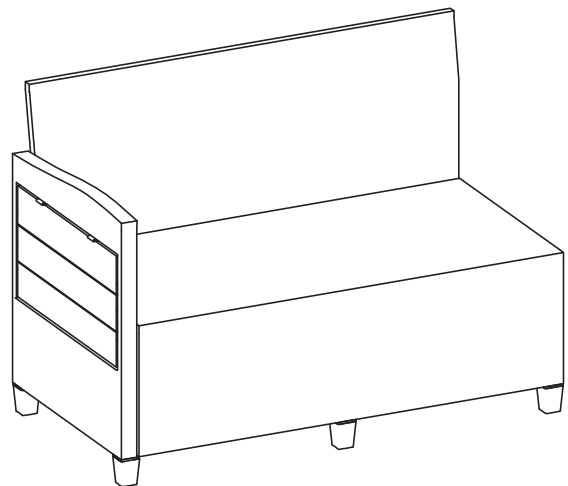

Step 5 (bench left assembly)

Connect the bench seat frame (E) & bench back frame (F), tighten allen bolts (3) with allen key (1)

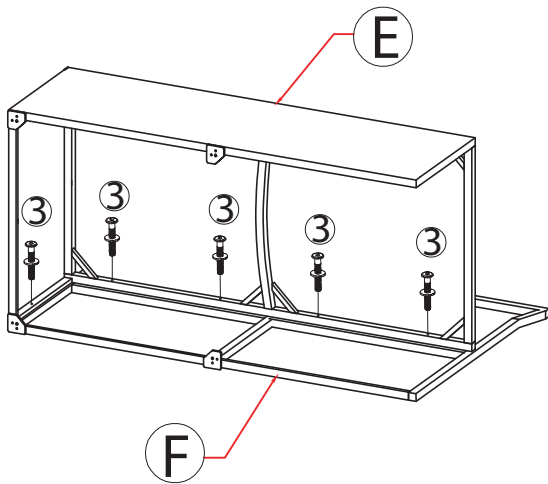

(E)x1 (F)x1 (3)x5

Step 6

Connect the part from step 5, left arm frame (D), tighten allen bolts (3) with allen key (1)

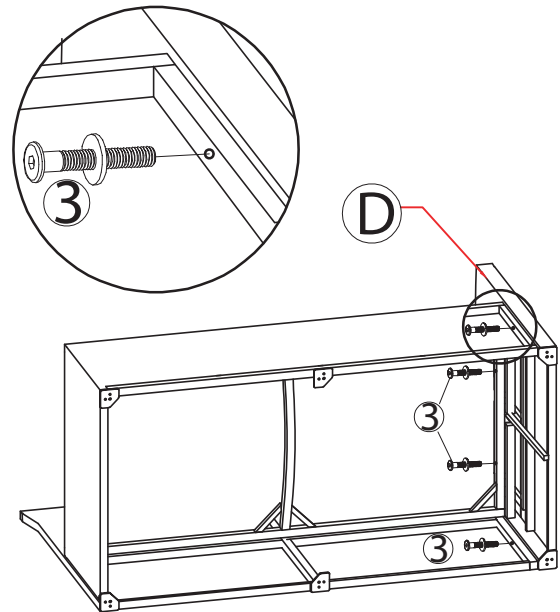

(D)x1 (3)x4

Step 7

Connect the part from step 6 & plastic feet (6), tighten allen bolts (5), (4) with allen key (1)

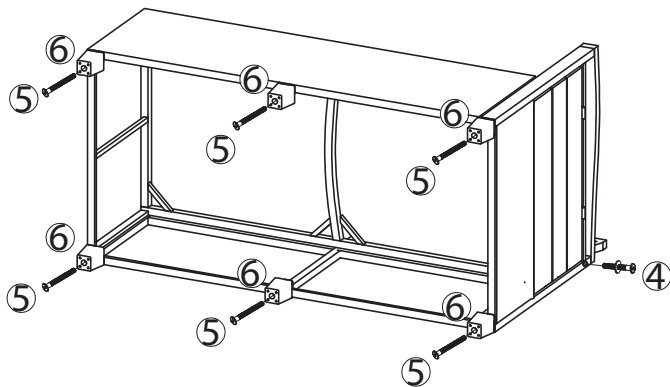

(5)x6 (6)x6 (4)x1

Step 8

Put the bench upright and make sure all legs are level, then firmly tighten bolts with Allen Key (1)

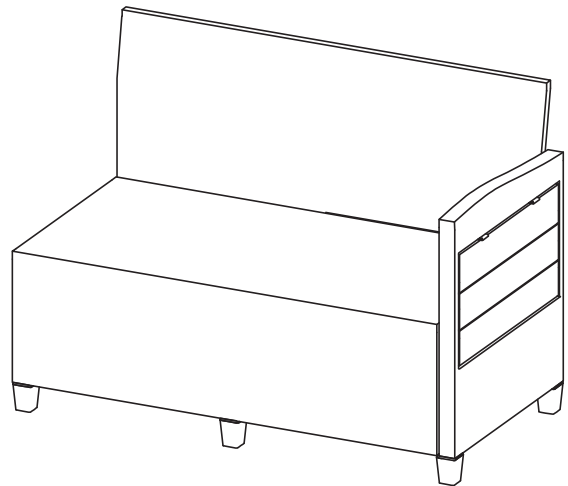

Step 9 (corner assembly)

Connect the bench seat frame (N), front frame (P) and side frame (Q), tighten allen bolts (3) with allen key (1)

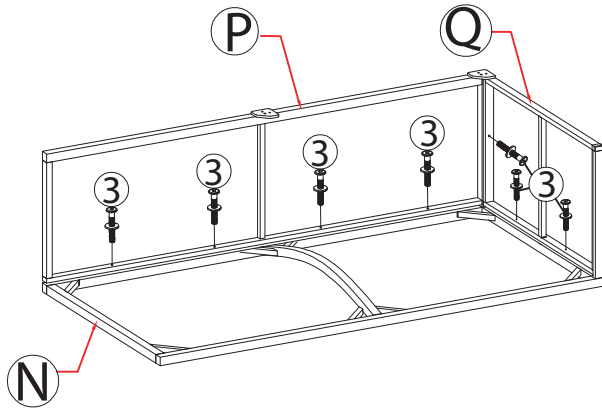

(P)x1 (Q)x1 (N)x1 (3)x7

Step 10

Connect the part from step 9, bench back frame (O), tighten allen bolts (3) with allen key (1)

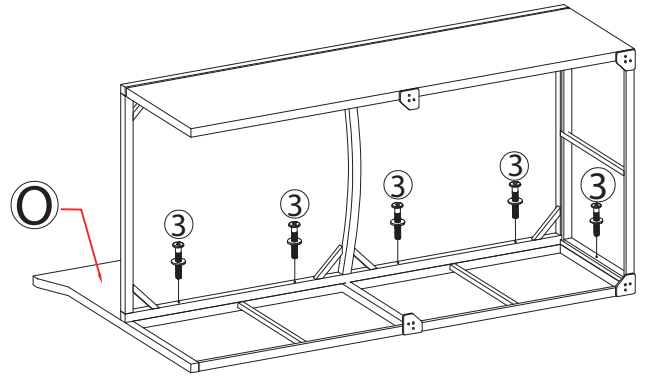

(O)x1 (3)x5

Step 11

Connect the part from step 10 and small bench back frame (M), tighten allen bolts (3) with allen key (1)

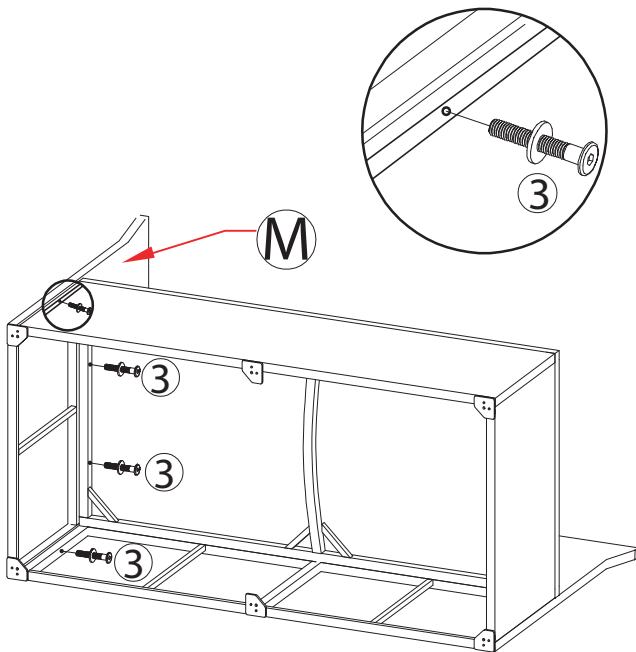

(M)x1 (3)x4

Step 12

Connect the part from step 11 and plastic feet (6), tighten allen bolts (5) with allen key (1)

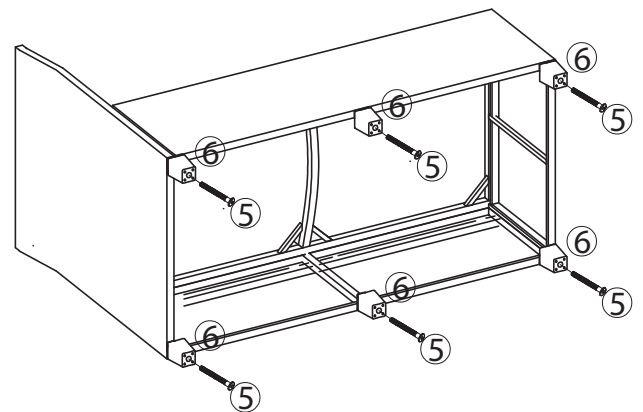

(5)x6 (6)x6

Step 13

Put the corner bench upright and make sure all legs are level, then firmly tighten bolts with Allen Key (1)

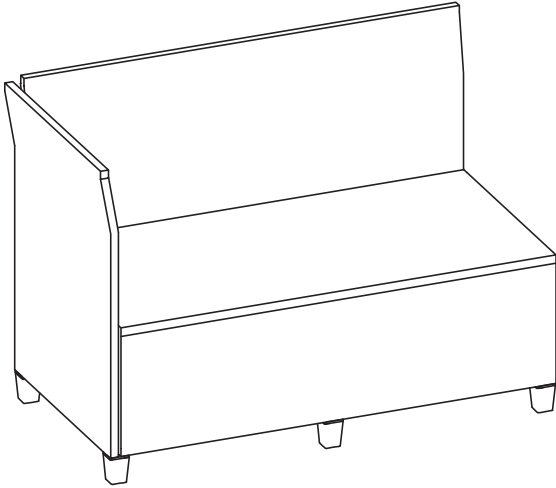

Step 14 (table assembly)

Connect the top table (G) & Legs table (I), tighten allen bolts (2) with allen key (1)

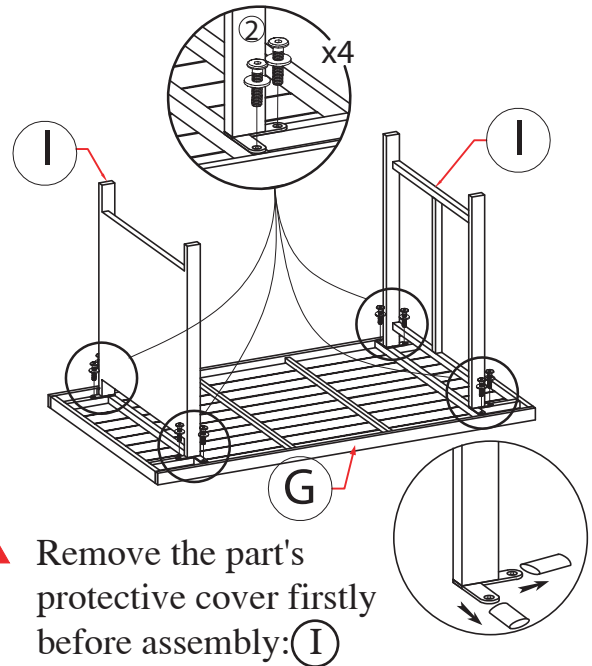

(1) x2 (G) x1 (2) x8

Step 15

Connect the part from step 14 & shelf frame (H), tighten allen bolts (2) with allen key (1)

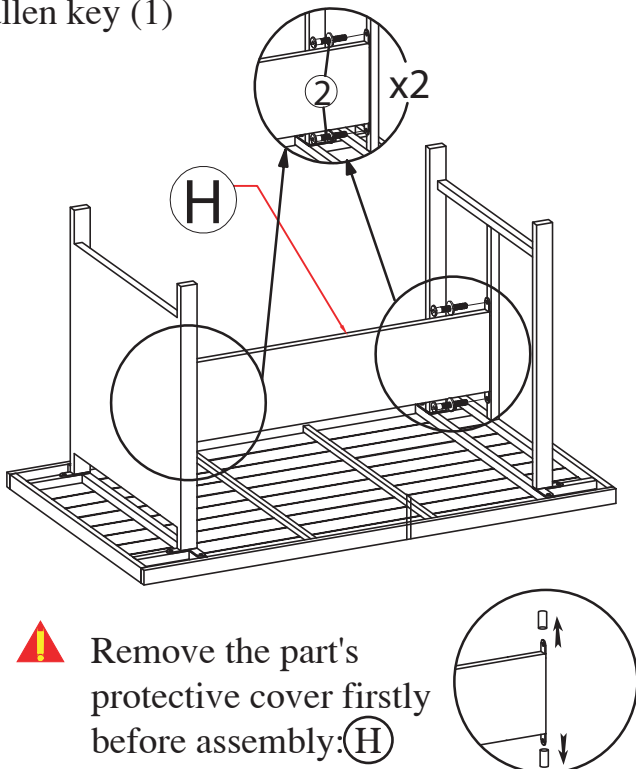

(H) x1 (2) x4

Step 16

Put the table upright and make sure all legs are level, then firmly tighten bolts with Allen Key (1)

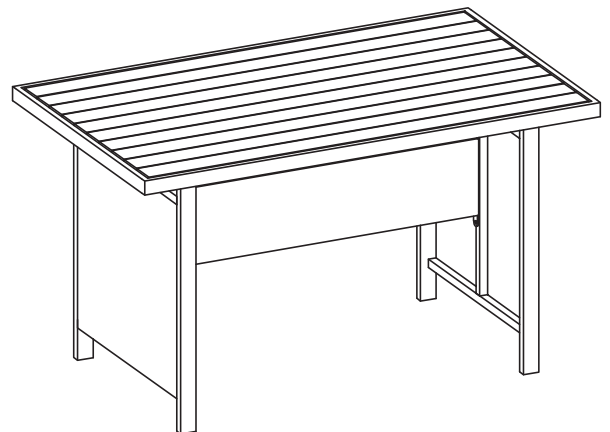

Step 17 (stool assembly)

Connect the top stool (J) and front frames (K), tighten allen bolts (3) with allen key (1)

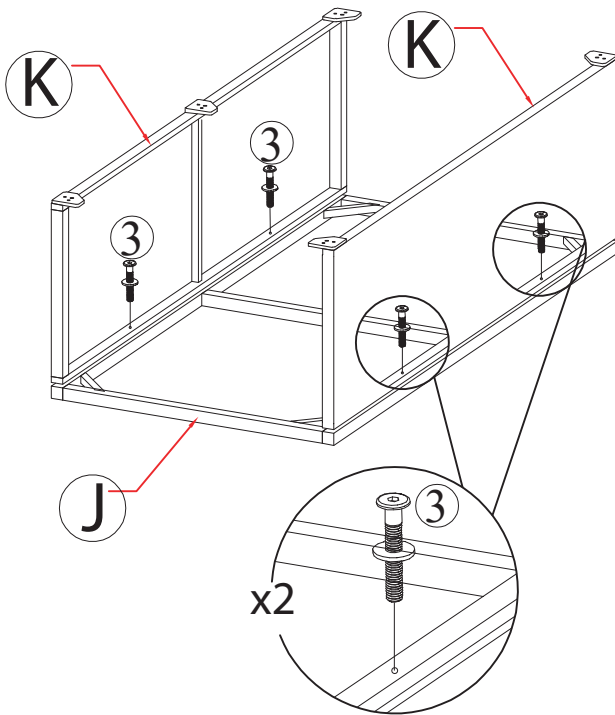

Ⓚx2 Ⓝx1 Ⓟx4

Step 18

Connect the part from step 17 and side frame (L), tighten allen bolts (3) with allen key (1)

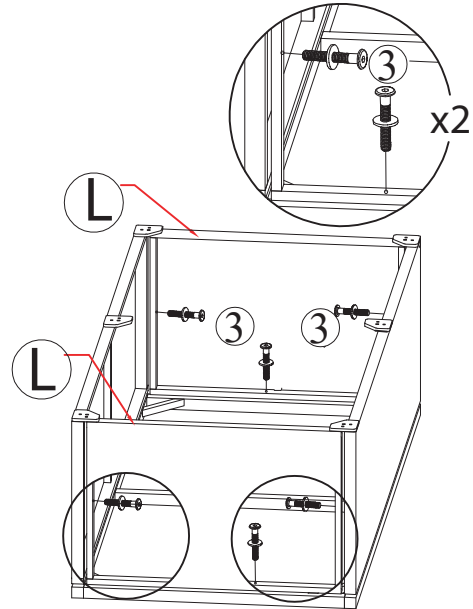

Ⓛx2 Ⓟx6

Step 19

Connect the part from step 18 & plastic feet (6), tighten allen bolts (5), firmly tighten bolts with allen key (1)

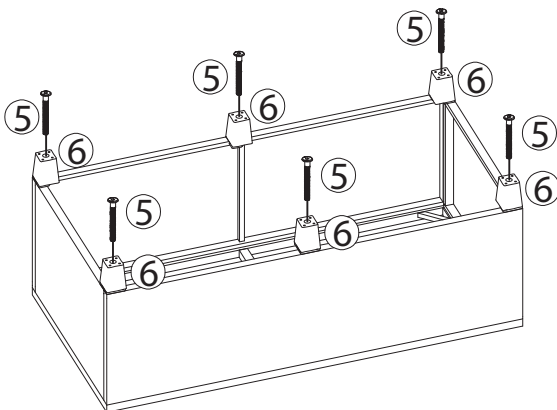

Ⓟx6 Ⓠx6

Step 20

Put the table upright and make sure all legs are level, then firmly tighten bolts with Allen Key (1)

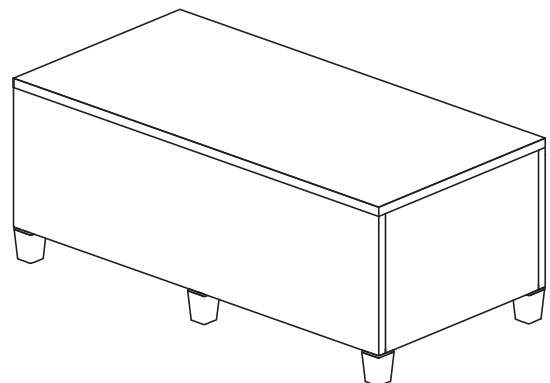

Step 19

Put the back cushions for benches and the seat cushions for benches & stool, connect the details together. Finished, lift up the wooden hands to get a new option.

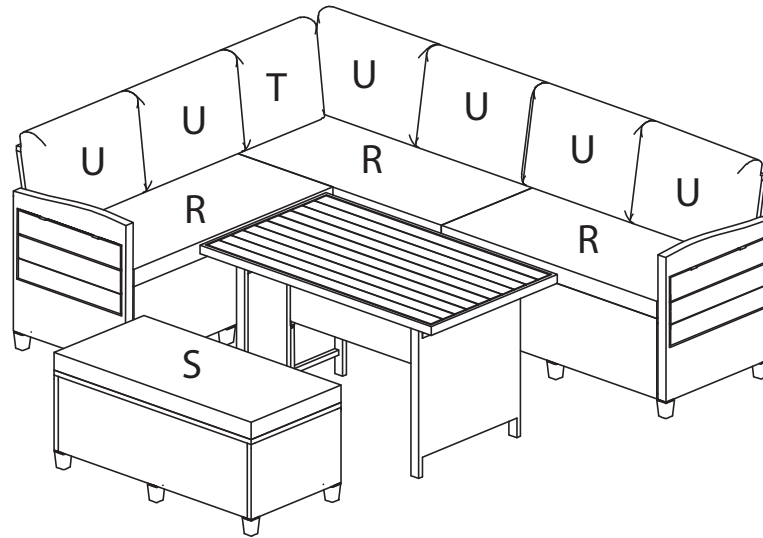

Rx3 **S**x1 **T**x1 **U**x6

Step 20 (FINISH)

Finished, lift up the wooden hand to get more options or lower it at your own discretion

