

ASSEMBLY INSTRUCTIONS



Fine Furniture for every stage of life

Dining Table

ASSEMBLY INSTRUCTIONS

ASSEMBLY TIPS:

1. Remove hardware from box and sort by size.
2. Please check to see that all hardware and parts are present prior to start of assembly.
3. Please follow attached instructions in the same sequence as numbered to assure fast & easy assembly.



WARNING!

1. Don't attempt to repair or modify parts that are broken or defective. Please contact the store immediately.
2. This product is for home use only and not intended for commercial establishments.



ASSEMBLY TIME

15 MINUTES

PARTS IDENTIFICATION

A TOP



1PC

B LEG



4PCS

HARDWARE IDENTIFICATION

1 ALLEN WRENCH
(M5 - BLK)



1PC

2 BOLT
(M8 x 80mm - RBW)



8PCS

3 LOCK WASHER
(M8 - RBW)



8PCS

4 FLAT WASHER
(M8 - RBW)



8PCS

ASSEMBLY INSTRUCTIONS
STEP 1

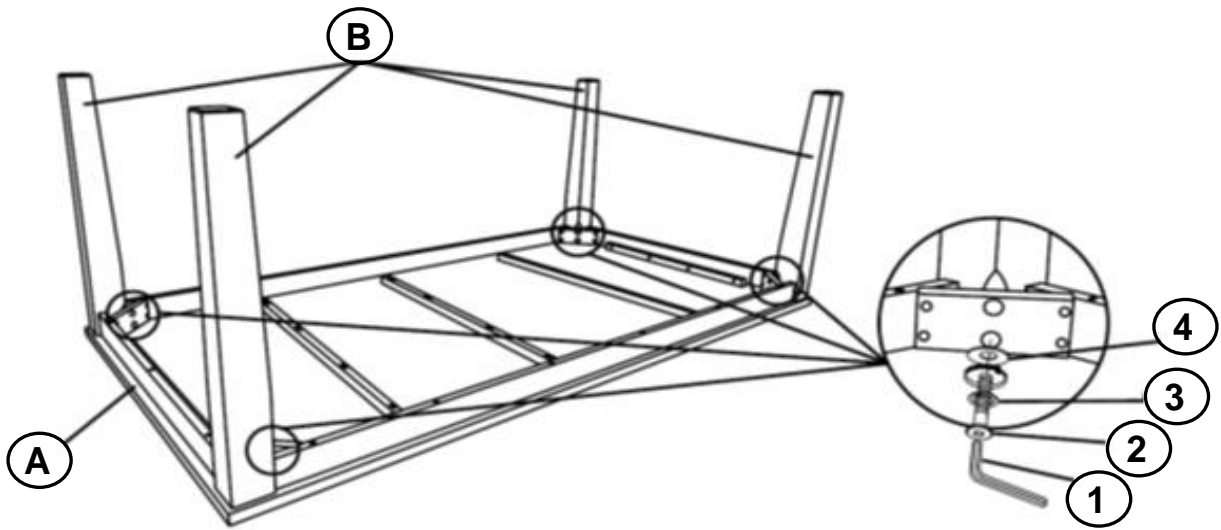

STEP 2
COMPLETE

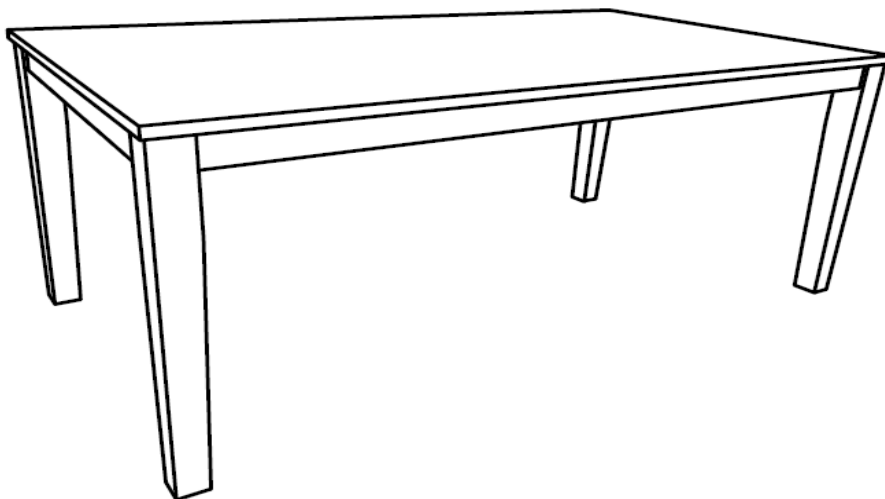

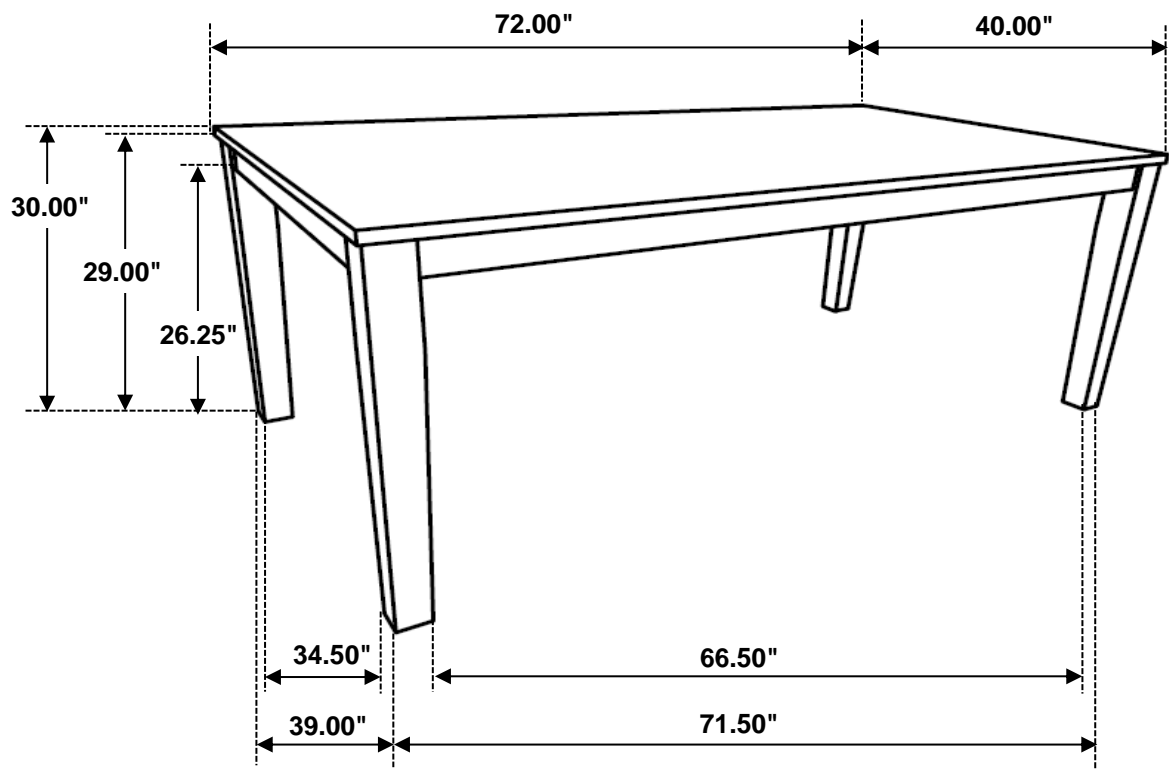

Note: Dimension tolerance $\pm 5\%$

ASSEMBLY INSTRUCTIONS



Fine Furniture for every stage of life

Dining Side Chair

ASSEMBLY INSTRUCTIONS

ASSEMBLY TIPS:

1. Remove hardware from box and sort by size.
2. Please check to see that all hardware and parts are present prior to start of assembly.
3. Please follow attached instructions in the same sequence as numbered to assure fast & easy assembly.



WARNING!



1. Don't attempt to repair or modify parts that are broken or defective. Please contact the store immediately.
2. This product is for home use only and not intended for commercial establishments.







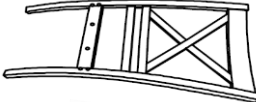
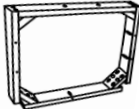

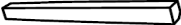
ASSEMBLY TIME

10 MINUTES

PARTS IDENTIFICATION

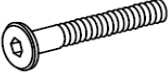
A	BACK FRAME		1PC
B	SEAT FRAME		1PC
C	SEAT CUSHION		1PC
D	FRONT LEG		2PCS

HARDWARE IDENTIFICATION

1	ALLEN WRENCH (M4 - BLK)		1PC
2	SHORT BOLT (M6 x 40mm - RBW)		2PCS
3	LONG BOLT (M6 x 70mm - RBW)		8PCS
4	LOCK WASHER (M6 - RBW)		10PCS
5	FLAT WASHER (M6 - RBW)		10PCS
6	FLAT HEAD SCREW (M4 x 25mm - RBW)		5PCS

NOTE:

Quantities shown are for one chair.

Phillips head screw driver is required in the assembly process; however, manufacturer does not provide this item.

ASSEMBLY INSTRUCTIONS

STEP 1

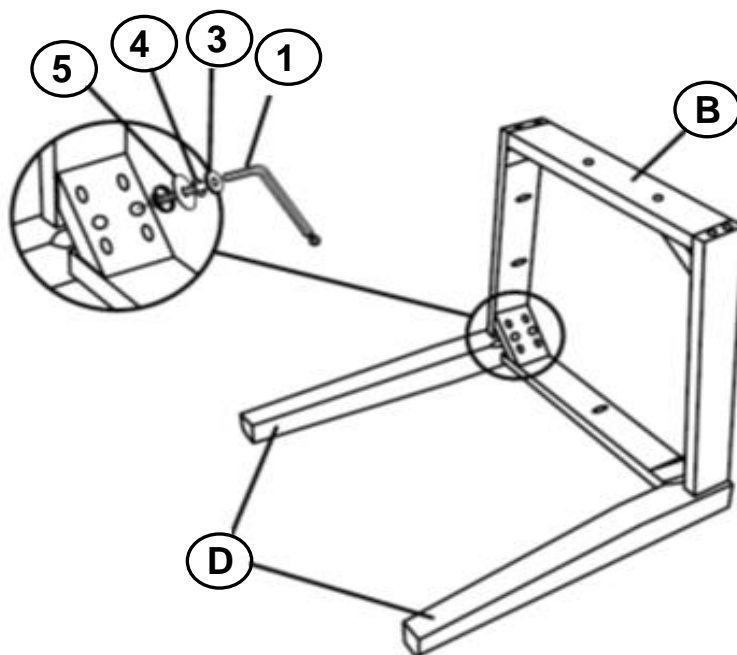

STEP 2

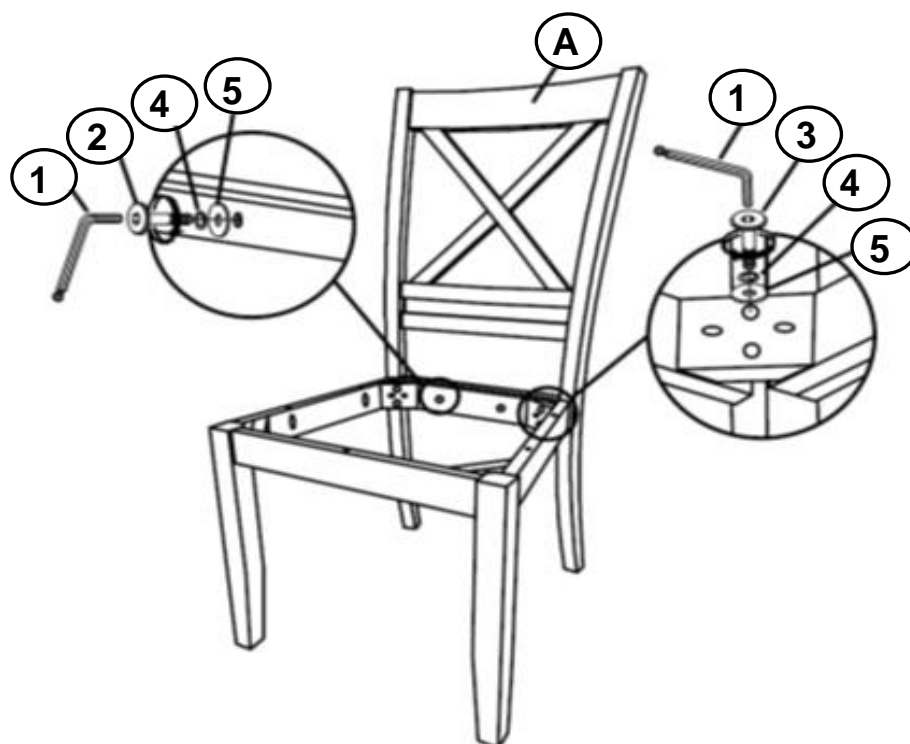

ASSEMBLY INSTRUCTIONS
STEP 3

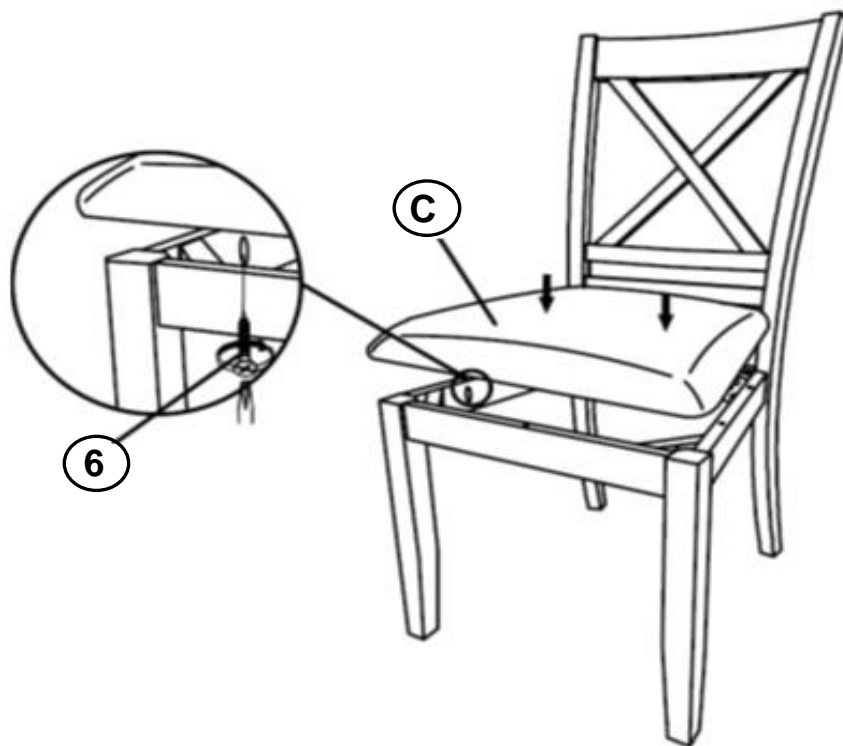

STEP 4
COMPLETE

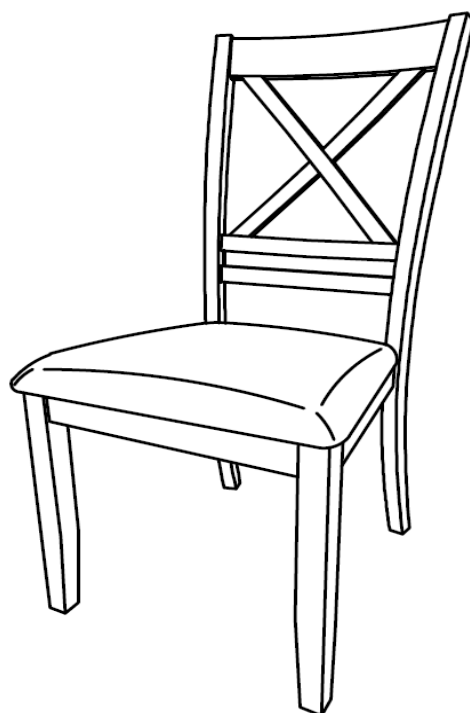

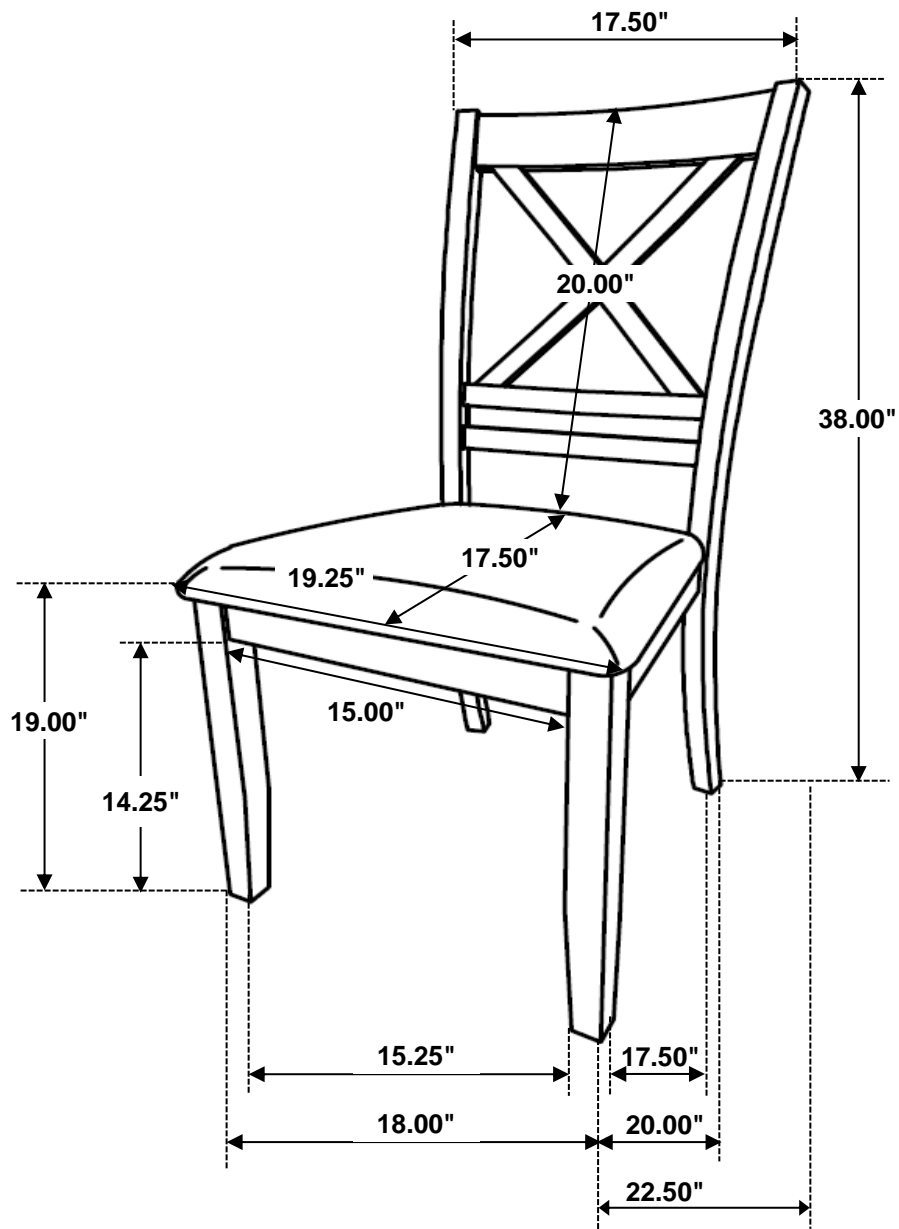

Note: Dimension tolerance $\pm 5\%$