

Notice de montage  
Assembling instructions  
Montageanleitung

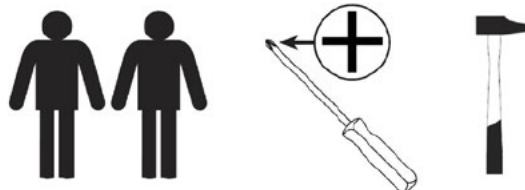

(Prod Ref.)

N° Pièce/Part/Teile

N° Pièce	Qte	Dimensions
1	1	895 x 396 x 16
2	1	895 x 396 x 16
3	1	700 x 395 x 16
4	1	700 x 395 x 16
5	1	700 x 395 x 16
6	3	513 x 376 x 16
7	1	342 x 704,50 x 3
8	4	329 x 152 x 16
9	4	360 x 120 x 12
10	4	360 x 120 x 12
11	4	299 x 120 x 12
12	4	354 x 308 x 3

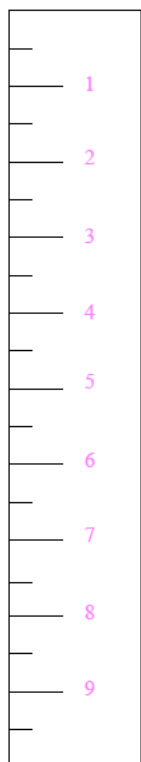
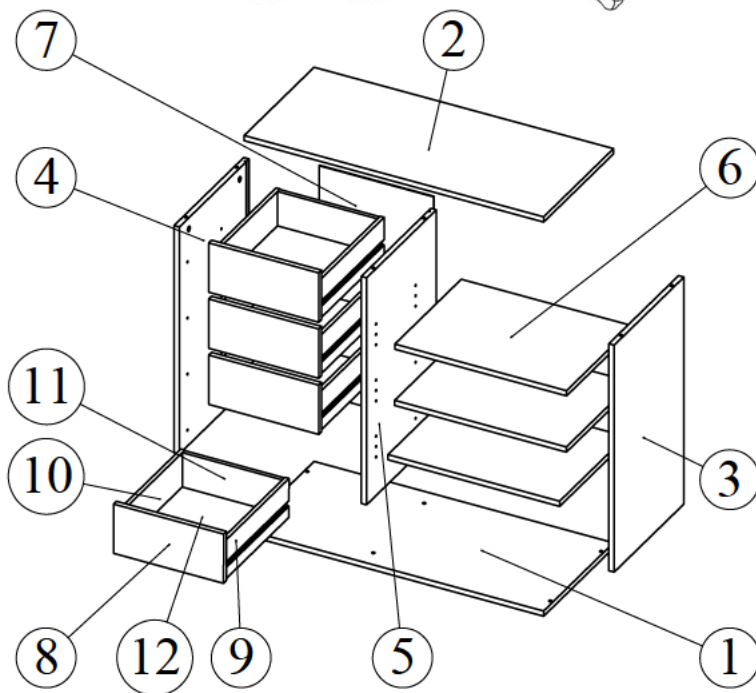

N° Pièce	Qte	Image
AA	6	
BA	6	
AB	8	
BB	8	
CA	6	
OH	8	
DD	12	
FB	16	
ITB	8	
ND	2	
IJ	2	
DA	24	
NM	2	
Clef	1	

1

BA  X6

AA  X6

FB  X16

DD  X12

OH  X8

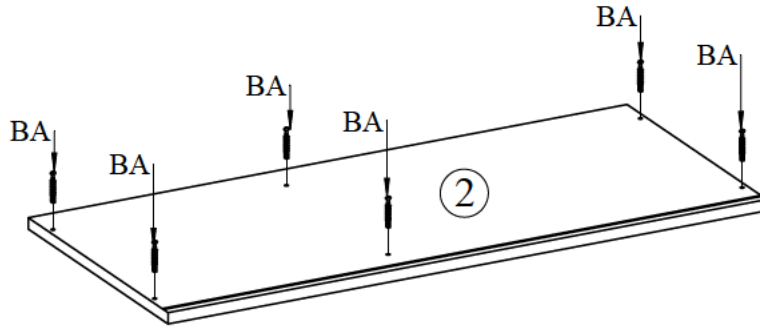
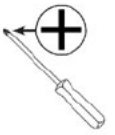

A

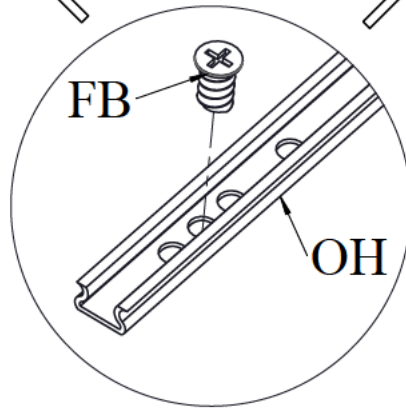
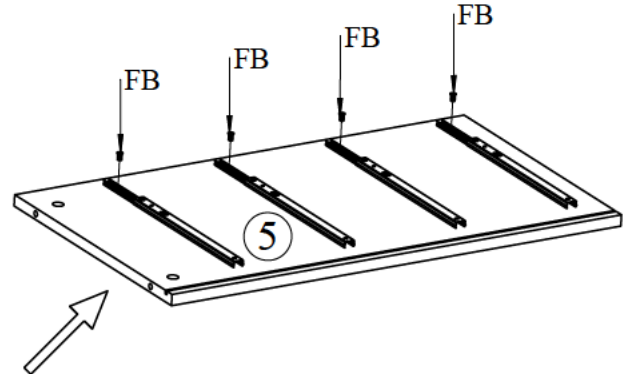
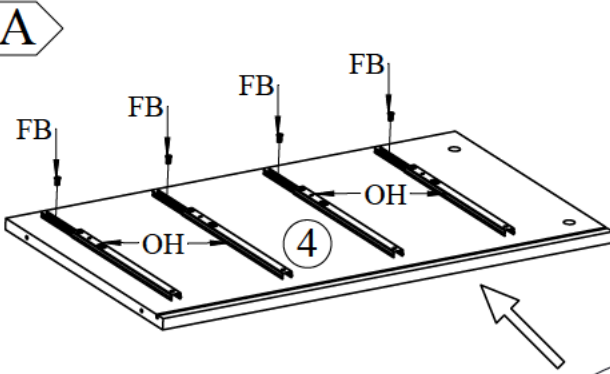

B

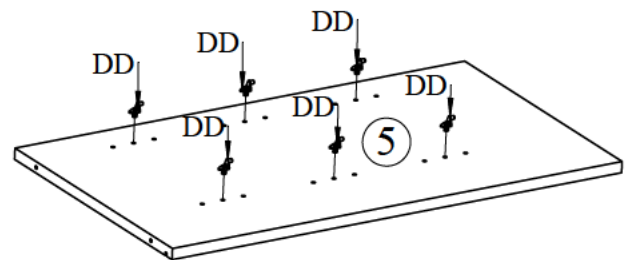
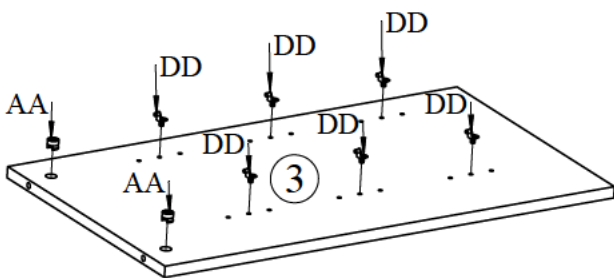
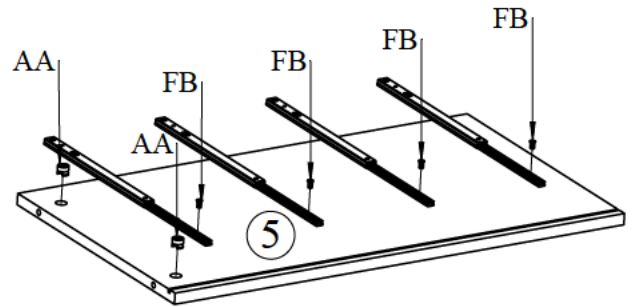
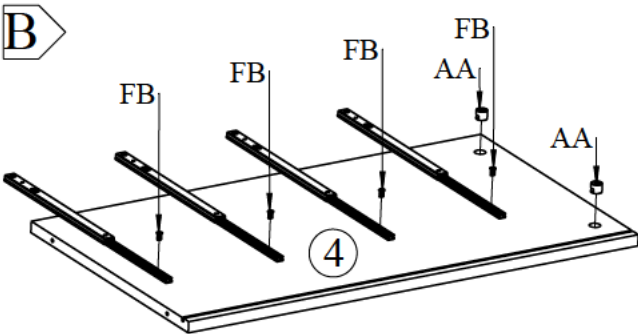

2

BB  X8

AB  X8

DA  X24

NM  X2

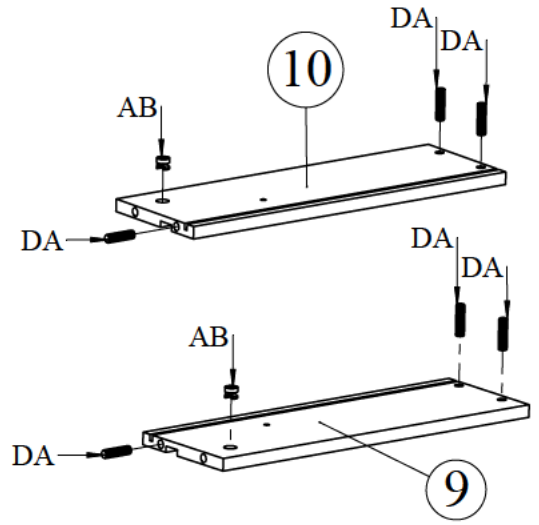
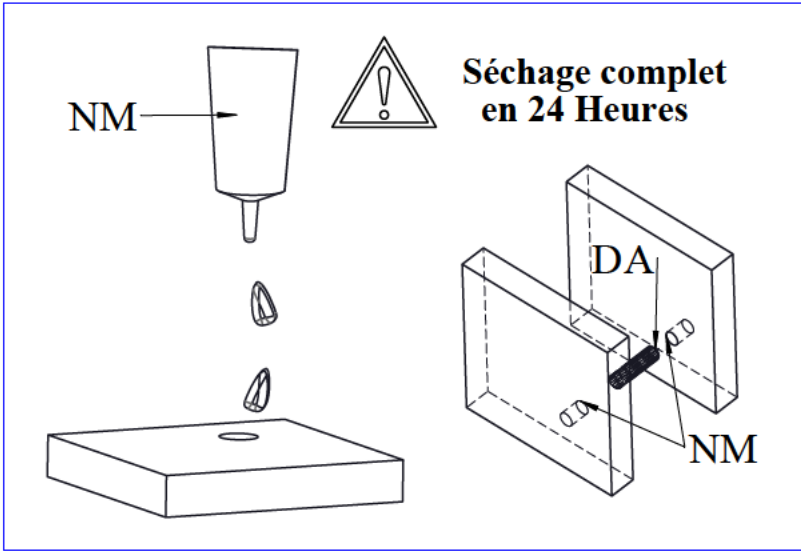
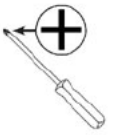

A

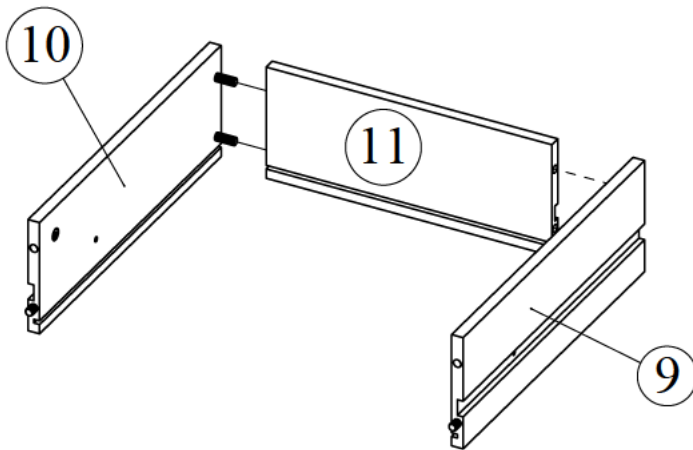

B

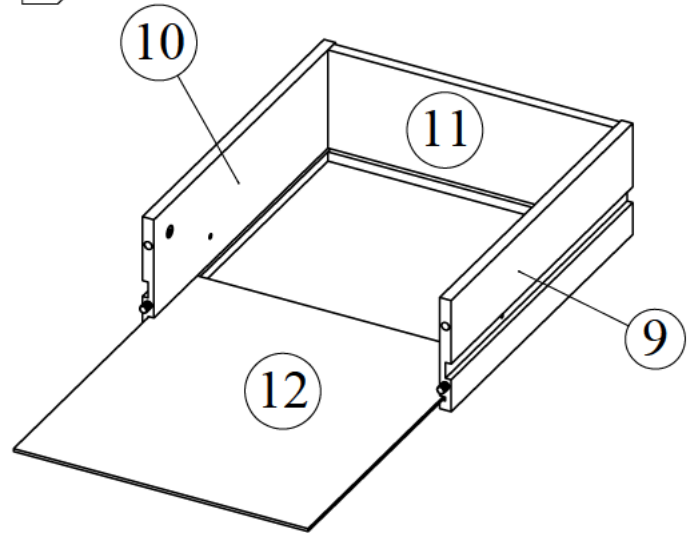

C

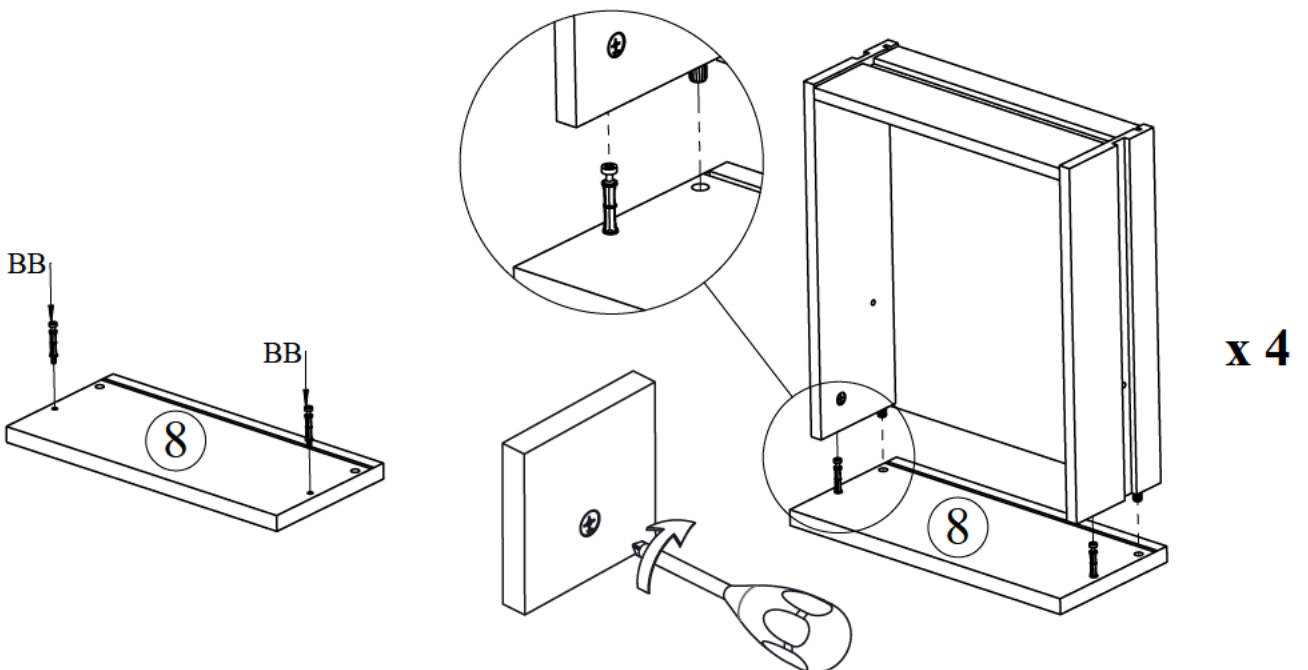

3

CA  x6

ITB  x8

IJ  x1

ND  x1

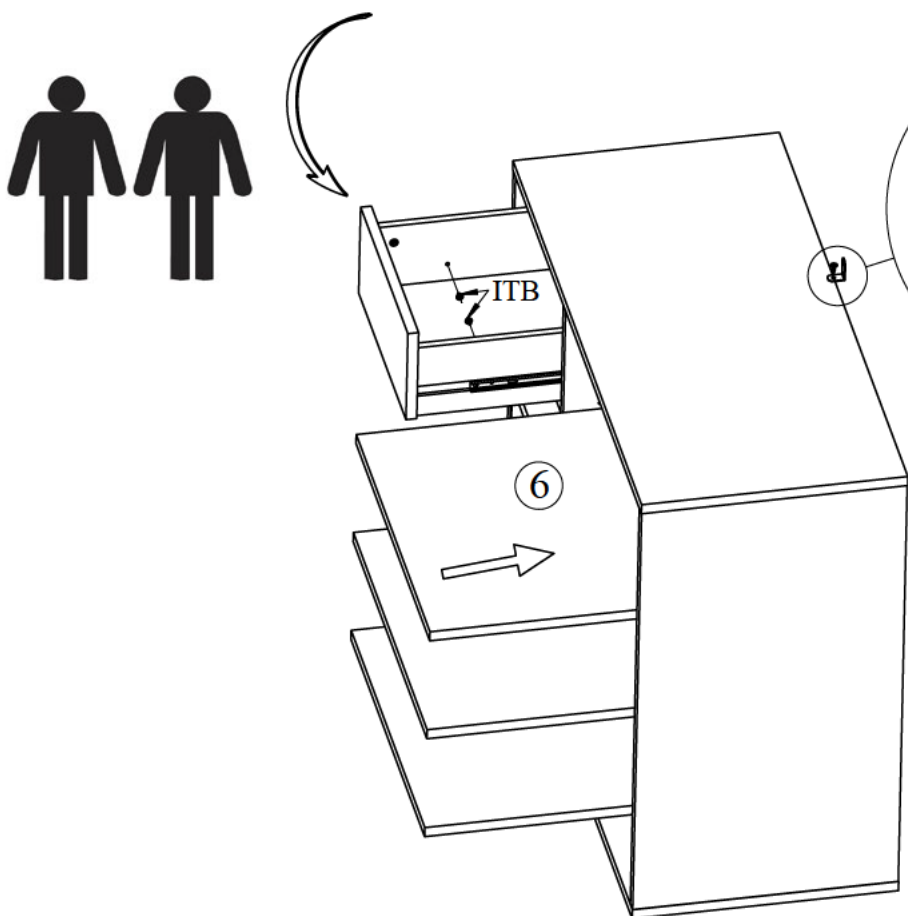
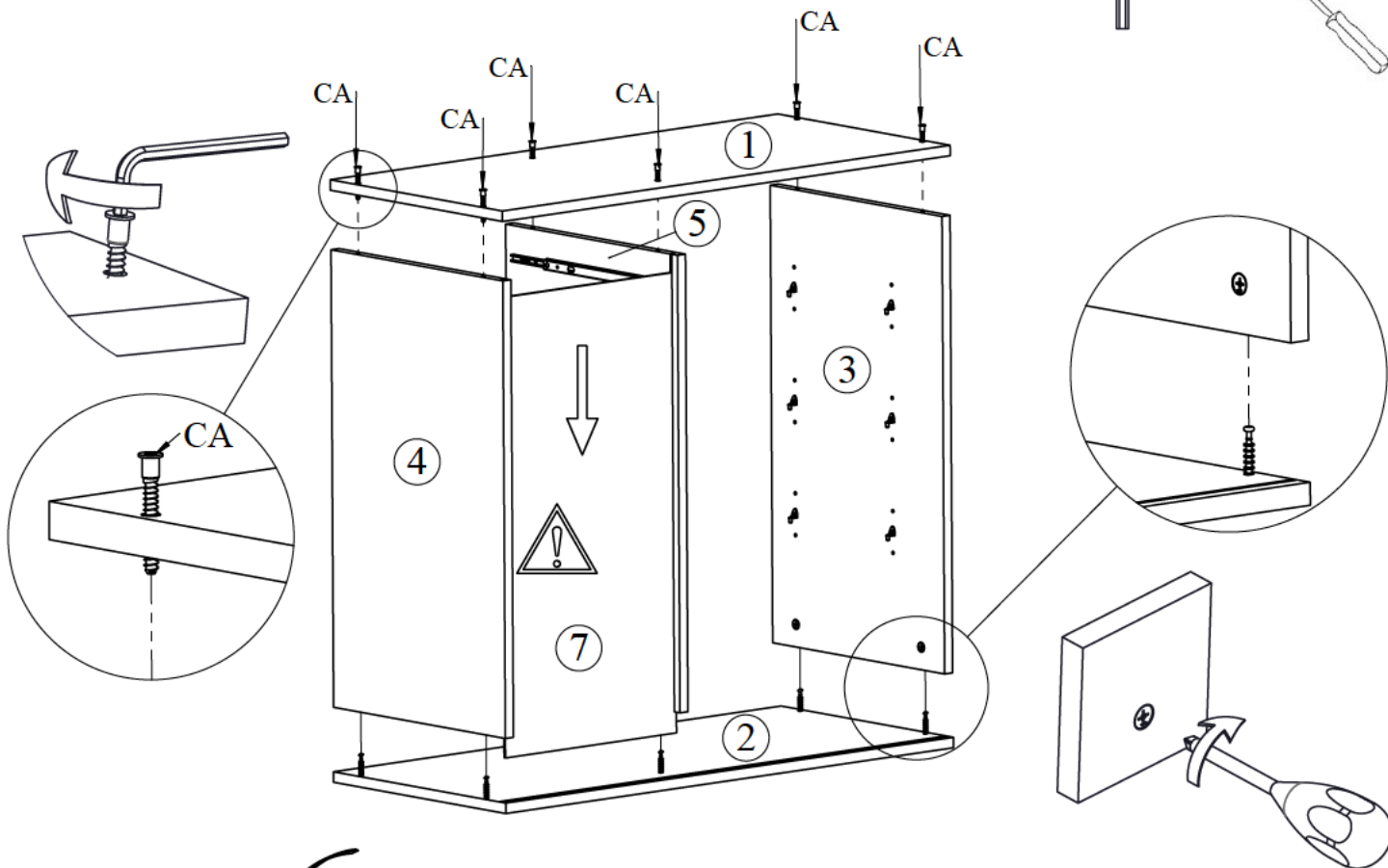
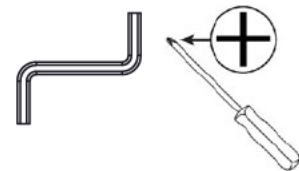

**FR.** Fixation murale impérative par une personne compétente avec vis et chevilles adaptées à la nature du mur.

**EN.** Unit must be secured to the wall by a competent person with appropriate screws and plugs

**DE.** Die Wandbefestigung muss von Fachmann und mit den dazu passenden Material montiert werden.



**INSTRUCTIONS D'ENTRETIEN**

Laver les surfaces à l'aide d'un chiffon doux, préalablement trempé dans une solution savonneuse (max. 1%)  
**ATTENTION!** Ne pas utiliser de produit contenant de l'alcool ou de l'abrasif.  
 Essuyer à l'aide d'un chiffon doux.

**CARE AND CLEANING INSTRUCTIONS**

Wash the surfaces with a soft cloth damped in a mild soap solution (max 1%).  
**NOTE!** Do not use cleaners containing alcohol or abrasives.  
 Wipe the surface dry with a soft cloth.

**PFLEGEHINWEIS**

Zur Reinigung und Pflege verwenden sie, ein feuchter Lappen mit Seifenlauge (max 1%) zum Abwischen  
**WICHTIG!** Keine alkoholhaltigen Mittel oder Schleifmittel verwenden.  
 Die Oberfläche mit einem weichen Tuch abtrocknen.