

Modern Extendable TV Stand

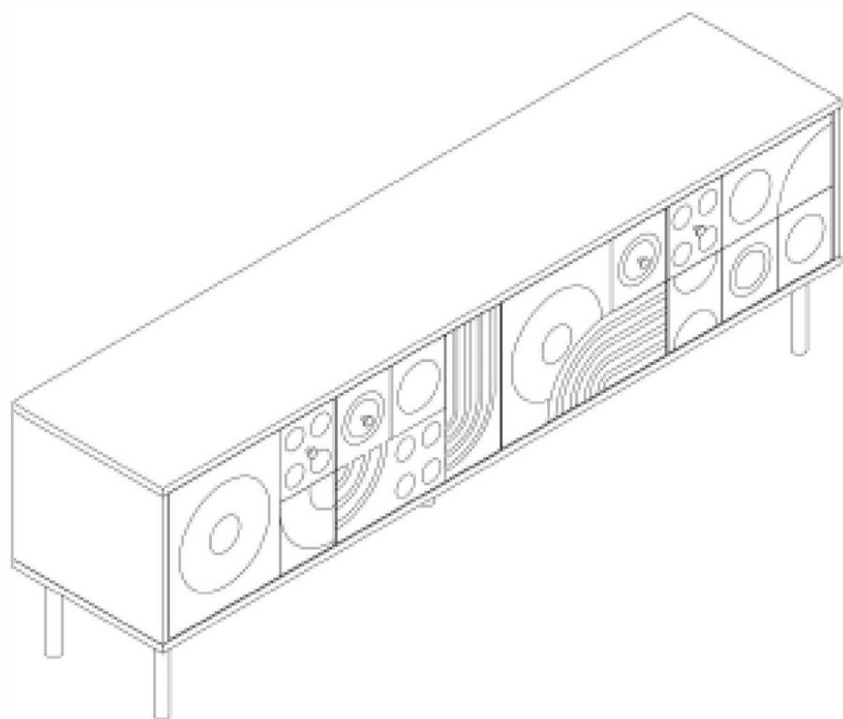

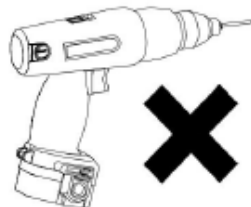
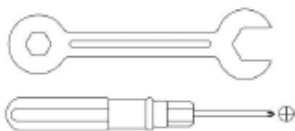
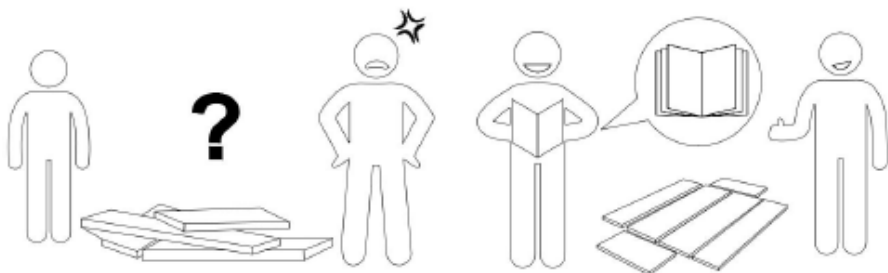

We recommend using hand tools for assembly.

If an electric screwdriver is used, reduce power and torque to avoid damage to the product.



Warm Tips



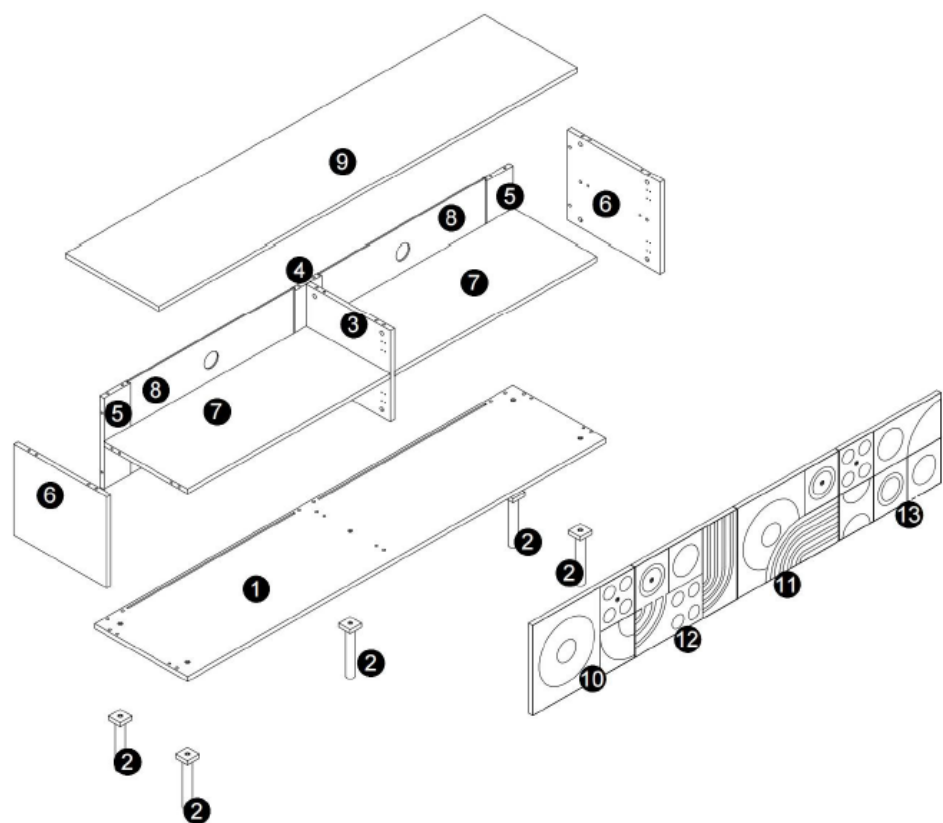





1. Carefully read these instructions and keep them for future reference.
2. Check the parts list and confirm everything's there before starting assembly.
3. When assembling, put all parts on a soft, smooth surface like a carpet to avoid scratches.
4. Don't fully tighten screws until all parts are confirmed in place to avoid misalignment.



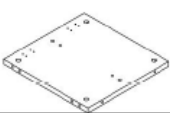
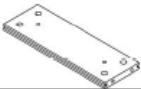
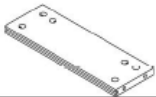

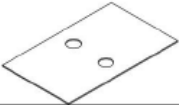

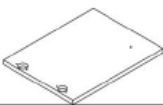
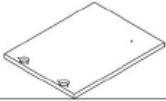

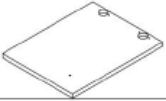







⚠ Caution

Make sure all parts are included. Most board parts are labeled or stamped on the raw edge.
Contact us for a free replacement if you encounter any damaged or missing parts.

Parts List

1 	2 	3 	4 	5 
1 pc	5 pcs	1 pc	1 pc	2 pcs
6 	7 	8 	9 	10 
2 pcs	2 pcs	2 pcs	1 pc	1 pc
11 	12 	13 		
1 pc	1 pc	1 pc		

Hardware List

A	B	C	D	E	F
 M6x35mm	 Ø15x12mm	 Ø8x30mm	 Ø8x35mm	 M3.5x14mm	
36 pcs	36 pcs	16 pcs	5 pcs	56 pcs	4 pcs
G	H	I	J	K	L
 Ø4x20mm	 	 Screwdriver	 	 	
4 pcs	8 pcs	1 pc	4 pcs	4 pcs	4 pcs
M	O				
 Ø8x40mm	 Ø7x38mm				
2 pcs	2 pcs				

Installation of Cams and Pins

Read each step carefully before starting. Each step of instruction should be performed in the correct order. If these steps are not followed in sequence, assembly difficulties may occur.

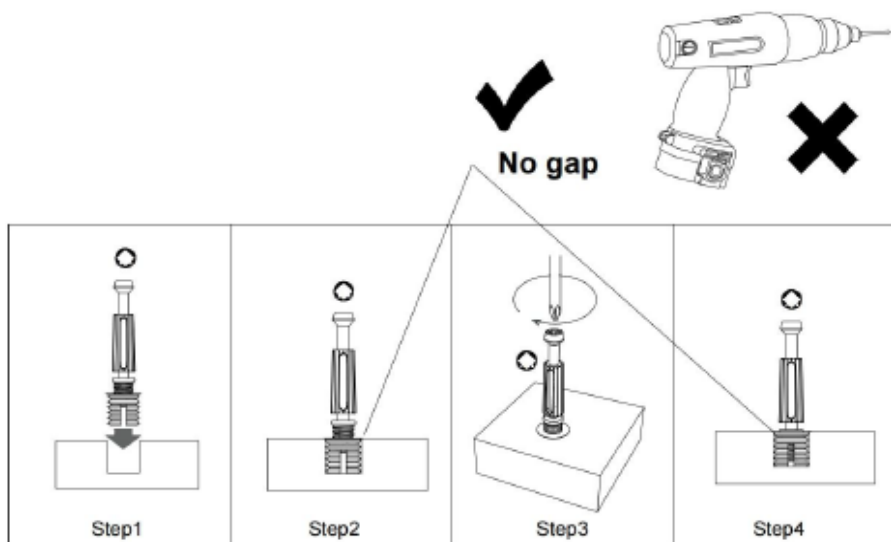

Screw the pin into the hole. Set the cams correctly by aligning the head of the cams with the lock pins. Lock the cam by turning the cam head with a screwdriver until it is tightened. Please do not use an electric screwdriver to assemble the unit.

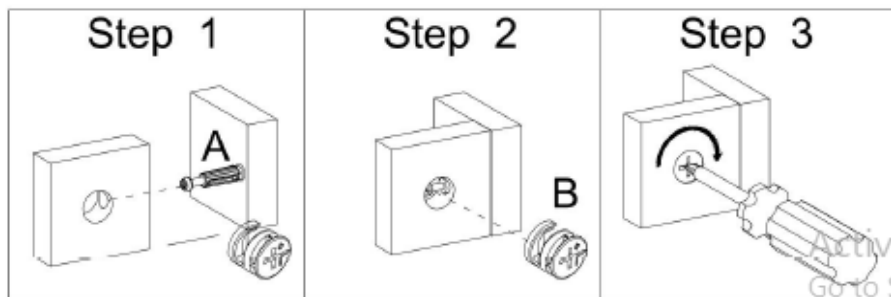

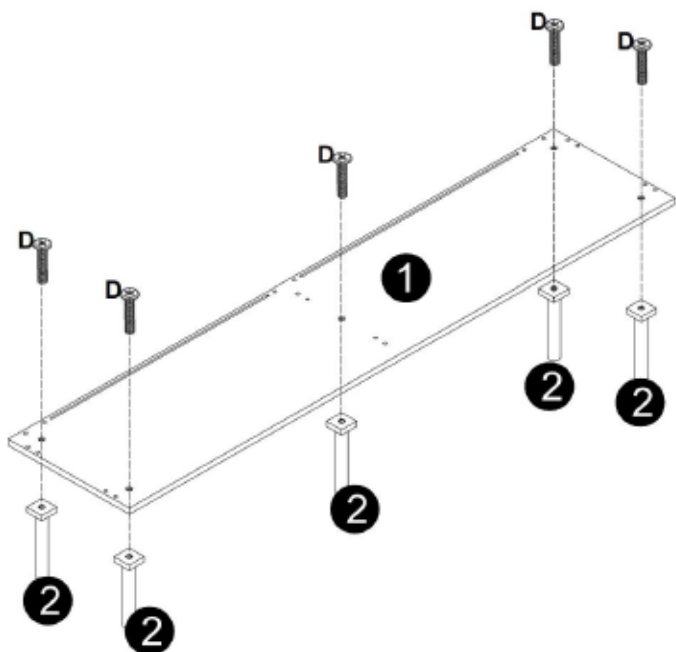

1

D

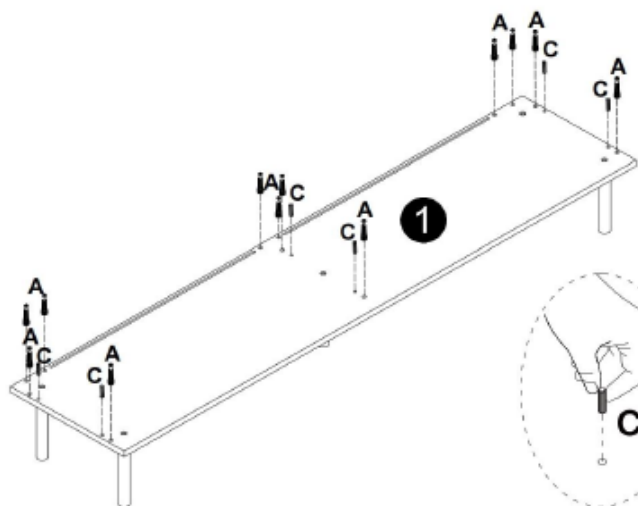
Ø8x35mm
5 pcs

2

A	C
	
M6x35mm	Ø8x30mm
12 pcs	6 pcs

3

A	M
	
M6x35mm	Ø8x40mm
4 pcs	2 pcs

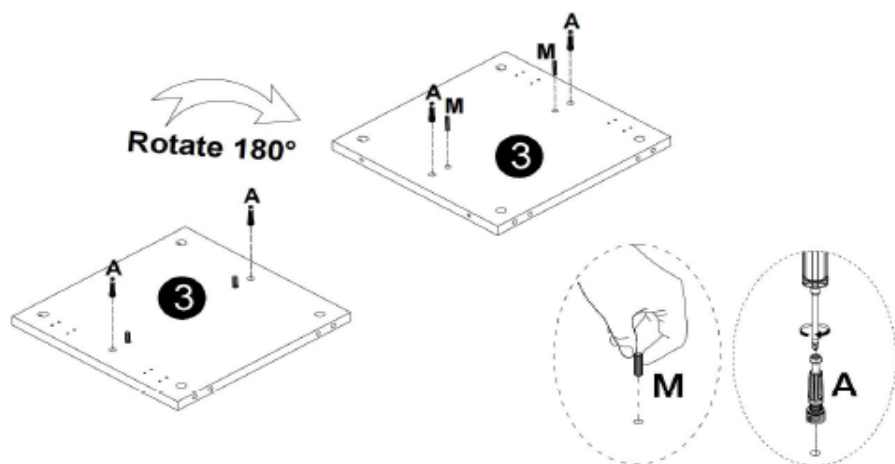
**4**

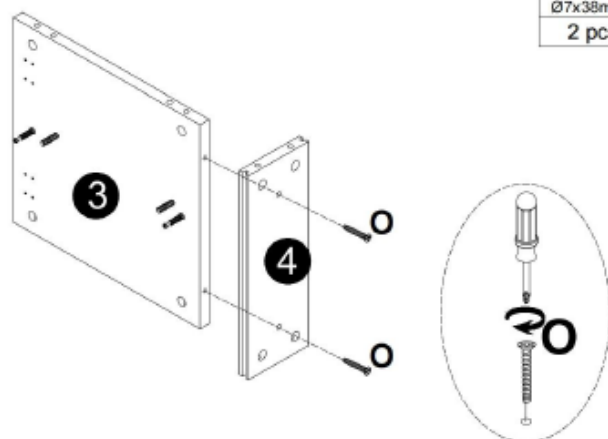

O

Ø7x38mm
2 pcs

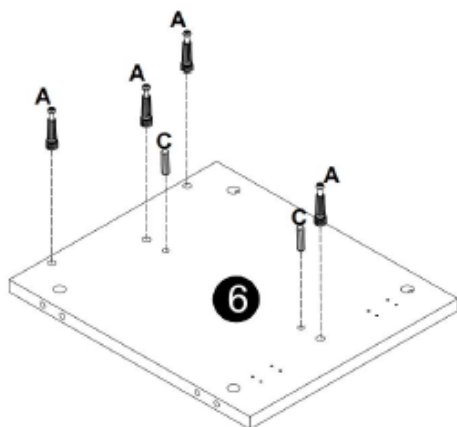

5



A	C
	
M6x35mm	Ø8x30mm
8 pcs	4 pcs

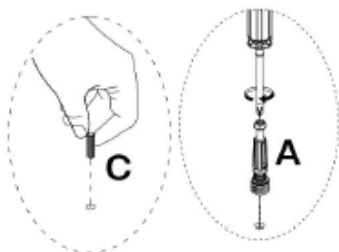

X2

6

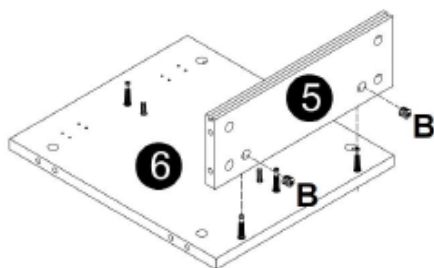
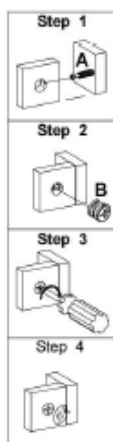

B

Ø15x12mm
4 pcs

X2

7

B

Ø15x12mm
4 pcs

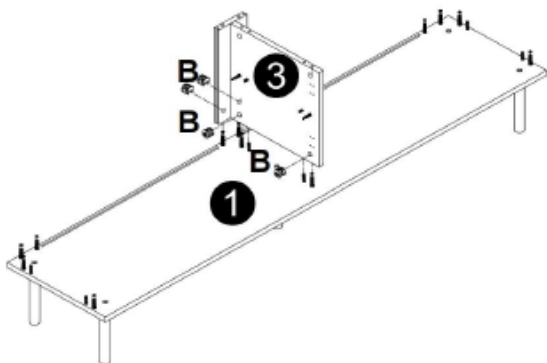
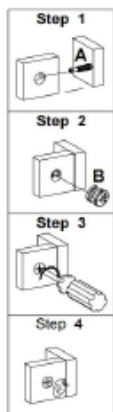



8

B

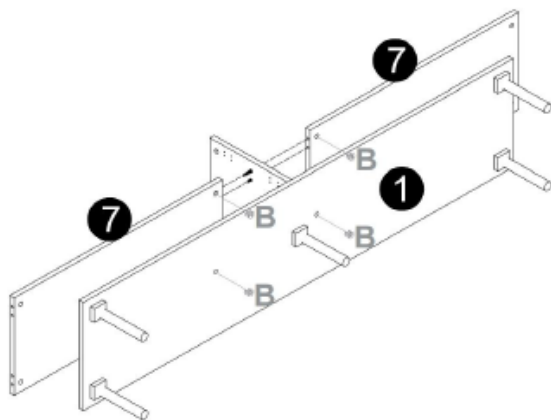
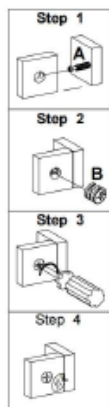
Ø15x12mm
4 pcs

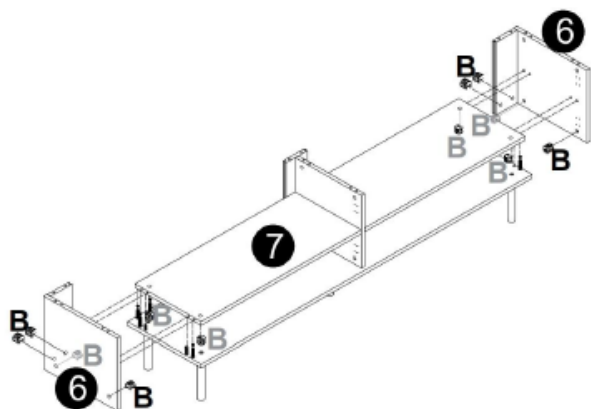
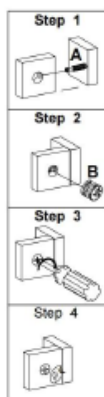

9

B

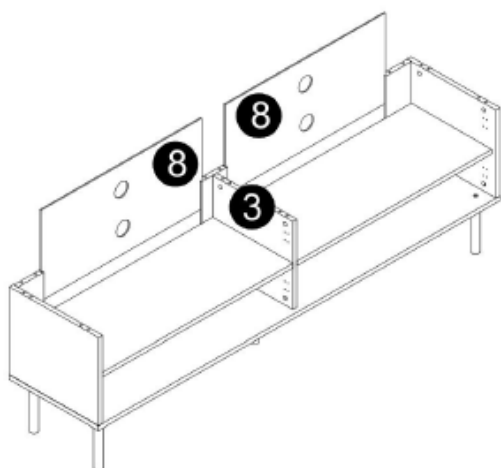
Ø15x12mm
12 pcs

10

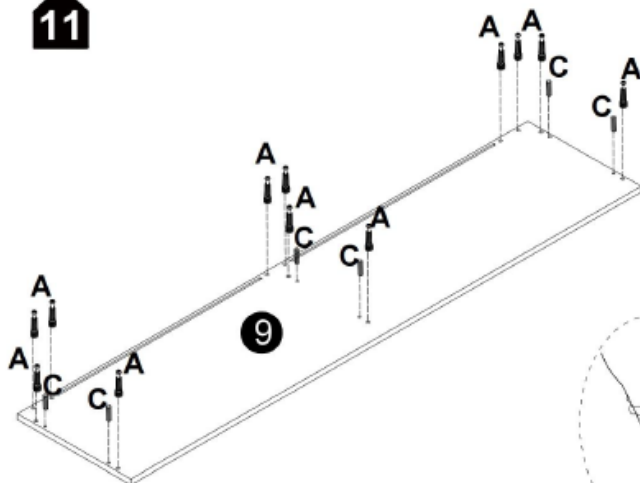
11

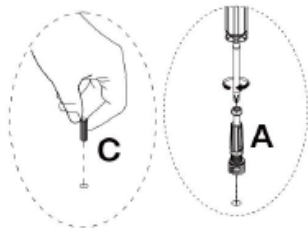

A	C
12 pcs	6 pcs



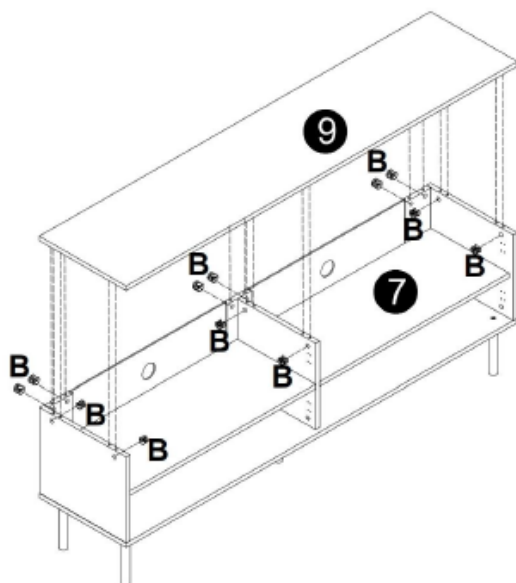
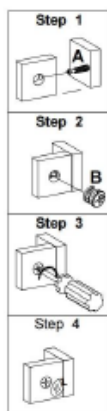

12





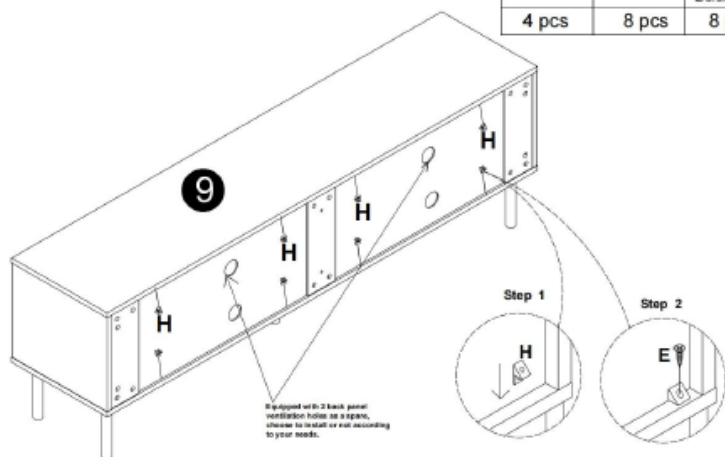

B
12 pcs

13

K	H	E
		
4 pcs	8 pcs	8 pcs





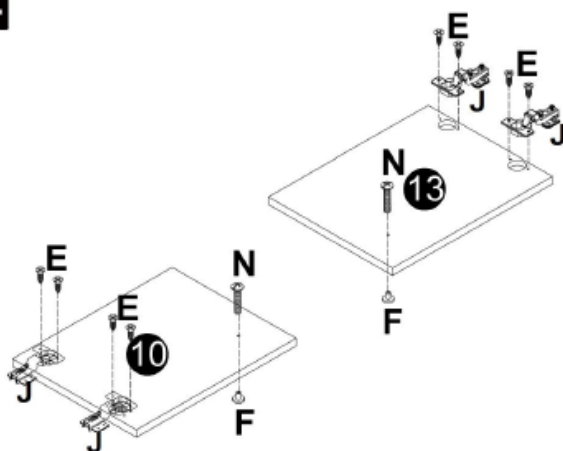

14

E	F
	
M3.5x14mm 8 pcs	2 pcs
J	N
	
4 pcs	M4x20mm 2 pcs

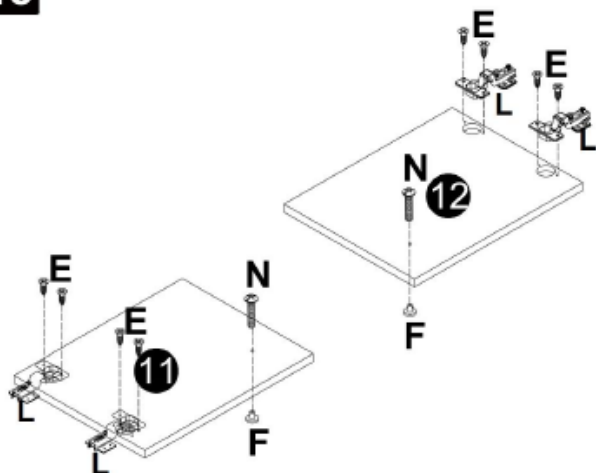



15

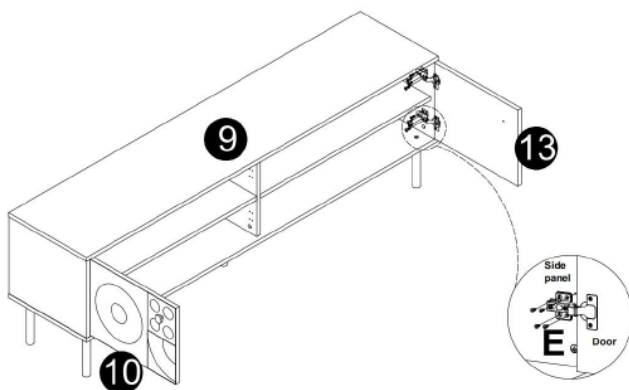

E	F
	
M3.5x14mm	
8 pcs	2 pcs
L	N
	
	M4x20mm
4 pcs	2 pcs

16



E

M3.5x14mm
16 pcs

To prevent the door hinge from falling off, please install 4 screws

17

E



M3.5x14mm

16 pcs

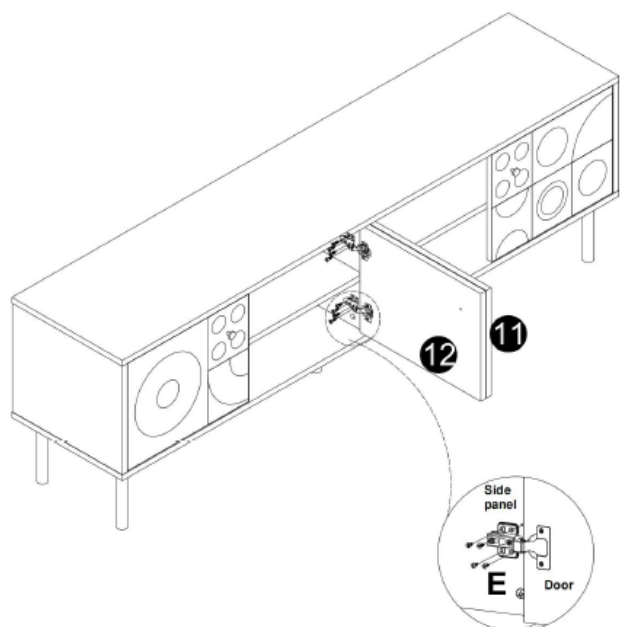

To prevent the door hinge from falling off, please install 4 screws

Step 1

Open the door.

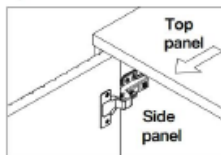

TO ADJUST YOUR DOORS TO MAKE THE GAPS MORE EVEN (OPTIONAL).

Step 2

Adjust the door panel to be flush with side panel and top panel edge.

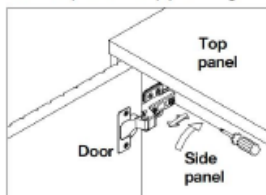

Loosen the screw indicated a little, adjust the hinge to right position (see step 2a & 2b), then tighten the screw.

Step 2a MOVE DOOR OUT

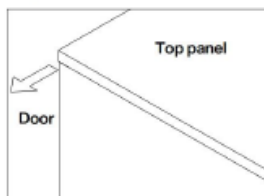

Step 2b MOVE DOOR INSIDE

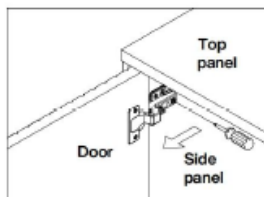
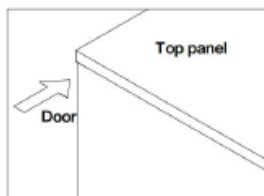

Pull the hinge forward a little.

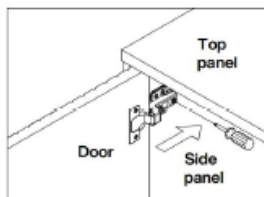

Pull the hinge back a little.

Step 3

Adjust the gap between door panel and side panel.

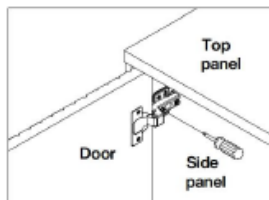

Loosen or tighten the screw indicated a little to adjust the gap between the door panels, adjust the hinge to right position (see step 3a & 3b).

Step 3a MOVE DOOR LEFT

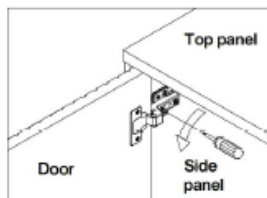
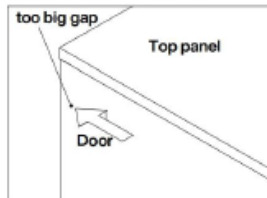

Turn the screw clockwise a little as shown to make the gap small.

Step 3b MOVE DOOR RIGHT

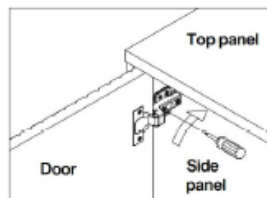
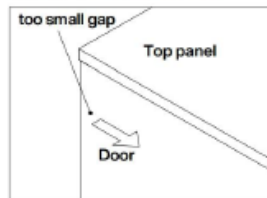

Turn the screw counterclockwise a little as shown to make the gap big.

Thank you for your support!

