

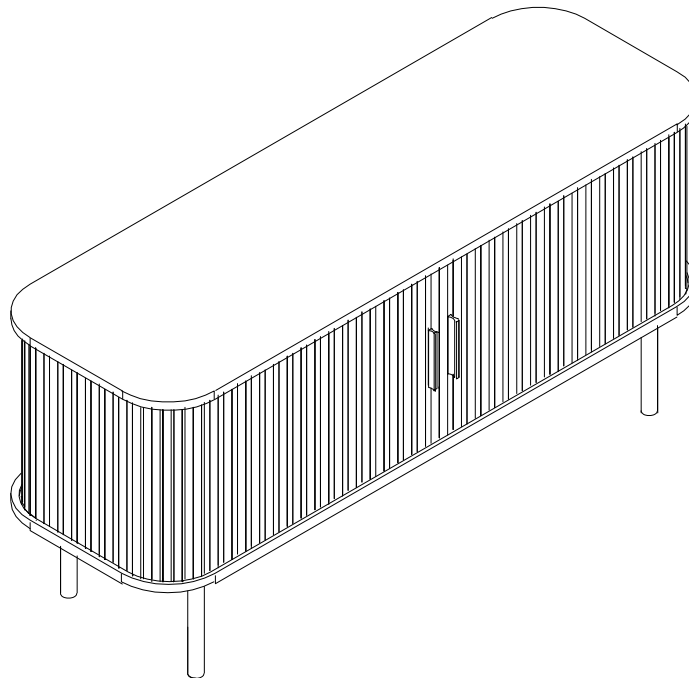

Attention: Please be sure to wax in the grooves of the top and bottom panel, otherwise the door will not move smoothly.



As this item contains many parts, please read the installation instruction carefully before installation . Please use tools properly and carefully.

Before You Start

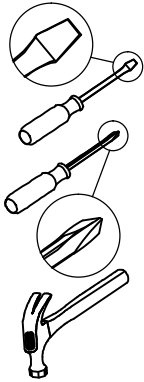

- ✓ Read through each step carefully and follow the proper order
- ✓ Separate and count all your parts and hardware
- ✓ Give yourself enough room for the assembly process
- ✓ Have the following tools: Flat Head Screwdriver, #2 Phillips Head Screwdriver and Hammer
- ✓ Caution: If using a power drill or power screwdriver for screwing, please be aware of to slow down and stop when screw is tight. Failure to do so may result in stripping the screw. (Assembly speed can be increased by using electric screwdriver)

Helpful Hints

PEOPLE NEEDED FOR ASSEMBLY: 1-2

- Open your item in the area you plan to keep it to avoid excessive heavy lifting.



- Identify, sort and count the parts before attempting assembly.

- Compression dowels are lightly tapped in with a hammer.



- Slides are labeled with an **R** (right) and **L** (left) for proper placement.



- Make sure to always face the point on the top of the Cam Lock towards the outer edge.

- If there is a back panel in the package, please install it to make sure your unit is complete and sturdy.



- Please fix all the screws provided for the back panel which can enhance product stability. If it is difficult to fix it when tightening, it can be fixed with the help of a hammer and then tightened.



- Do NOT use harsh chemicals or abrasive cleaners on this item.



- Never push, pull, or drag your furniture.

Board Identification

Not actual size

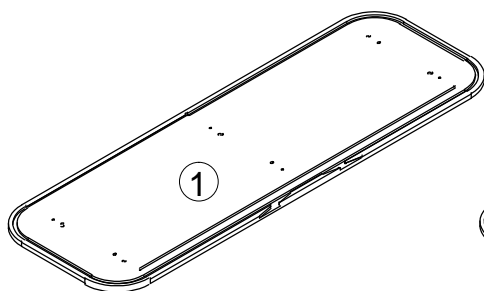

TOP PANEL
Qty:1

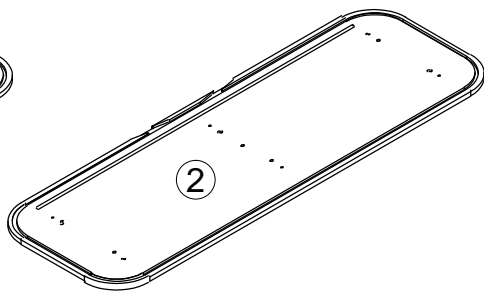

BOTTOM PANEL
Qty:1

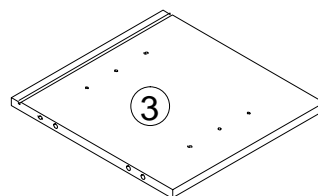

LEFT SIDE PANEL
Qty: 1

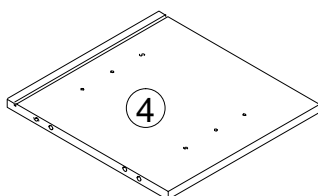

RIGHT SIDE PANEL
Qty: 1

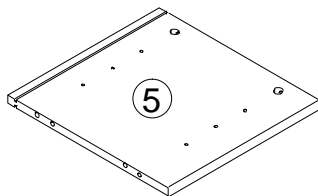

MIDDLE VERTICAL PLATE
Qty:1

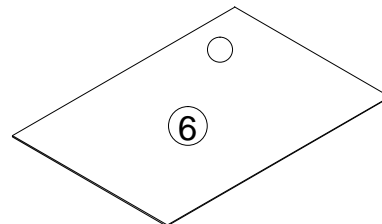

BACK PANEL
Qty: 2

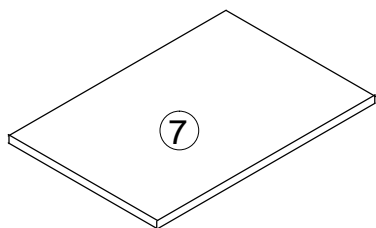

SHELF PANEL
Qty: 2

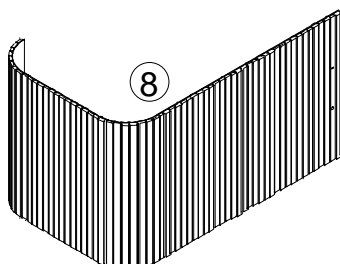

DOOR PANEL
Qty:1

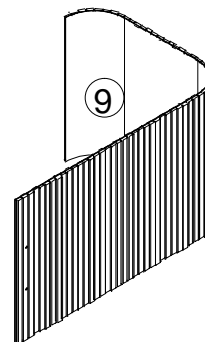

DOOR PANEL
Qty: 1

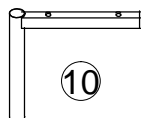

LEG
Qty: 2

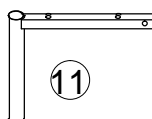

LEG
Qty: 2



LEG
Qty: 1

Part List

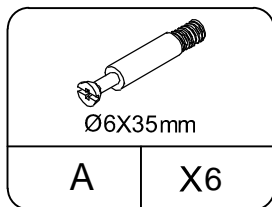

CAM BOLT
spare: 1

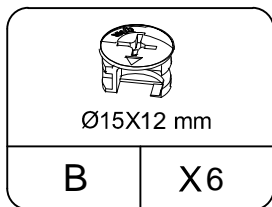

CAM LOCK
spare: 1

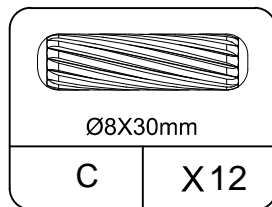

WOOD DOWEL
spare: 2

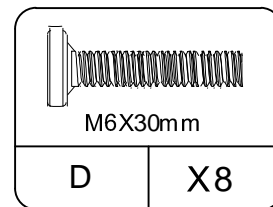

BOLT
spare:1

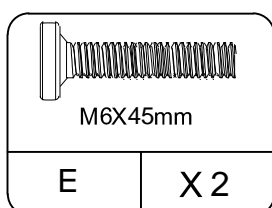

BOLT
spare: 1

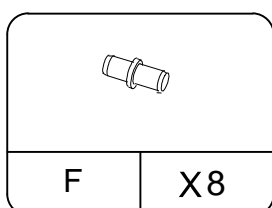

PANEL HOLDER
spare:1

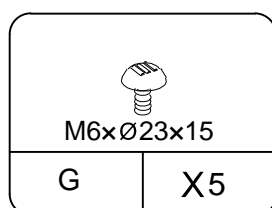

BOLT

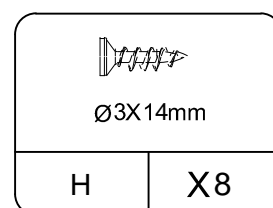

SCREW
spare: 1

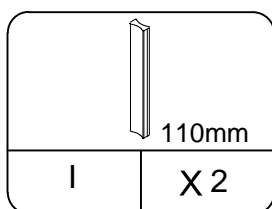

HANDLE

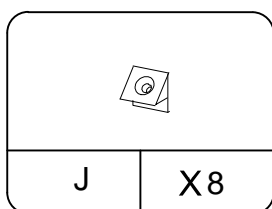

BACK PANEL BUCKLE
spare:1

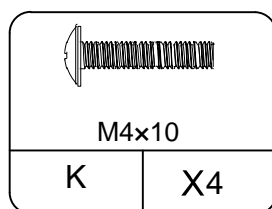

BOLT
spare:1

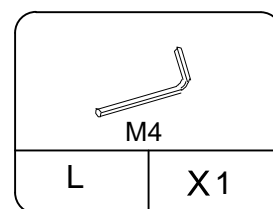

INNER HEXAGON SPANNER

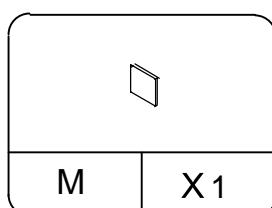

wax

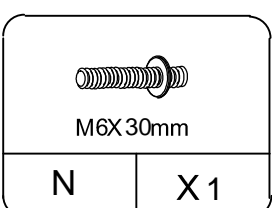

BOLT

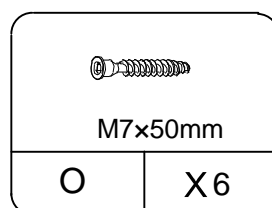

BOLT
spare: 1

Part List

Cam Lock Fastening System

Insert the cam bolt into the hole first, then insert the cam lock and lock it.

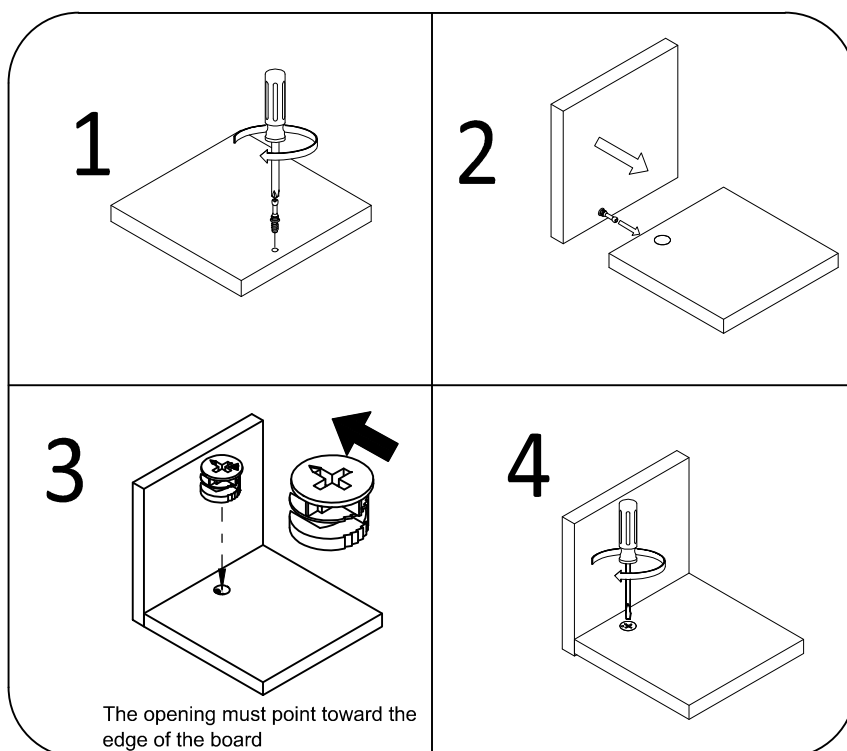

Board Identification

Not actual size

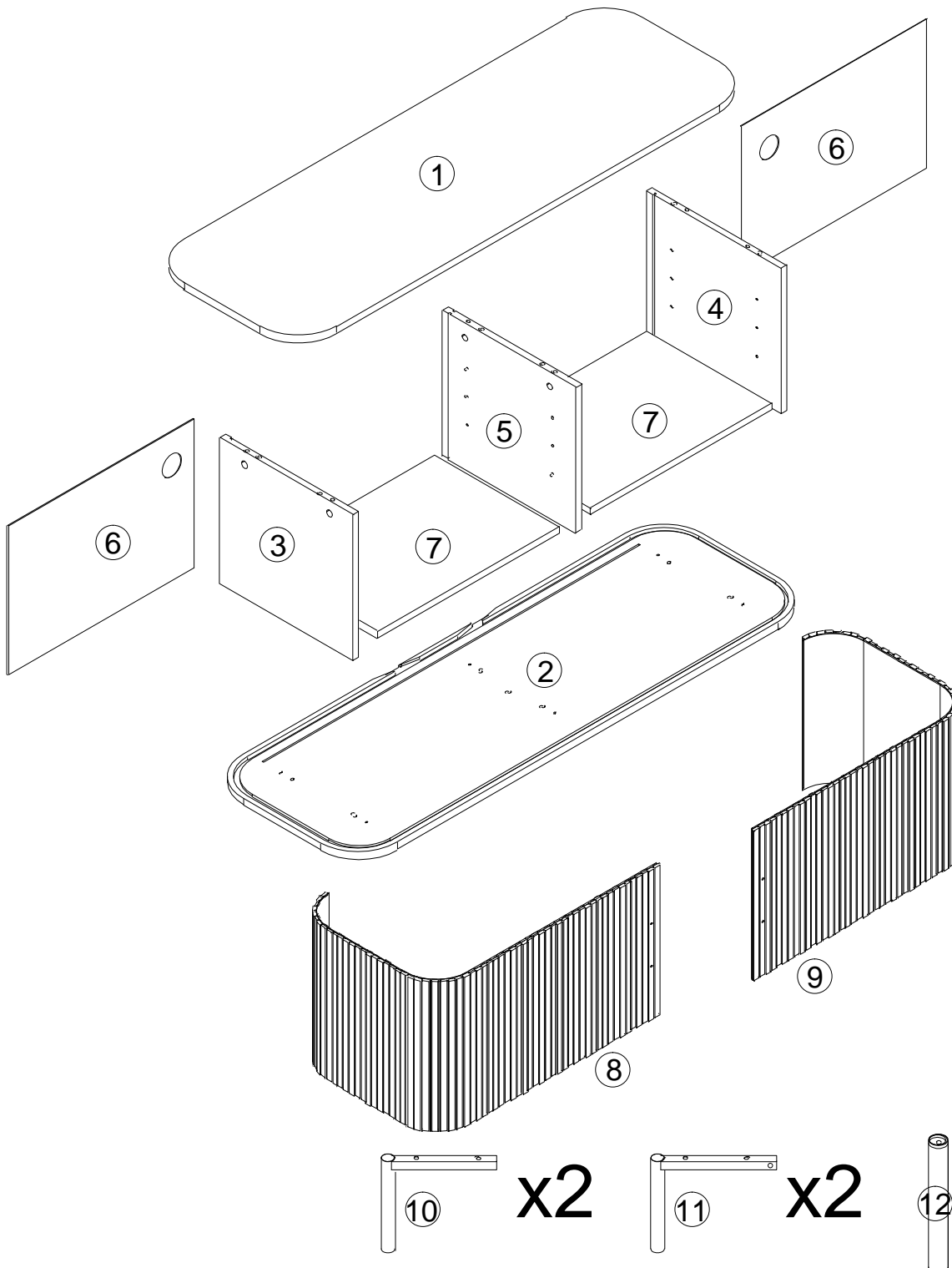

STEP1

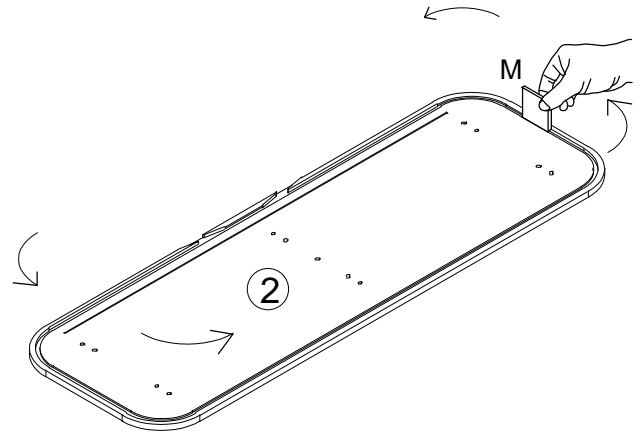
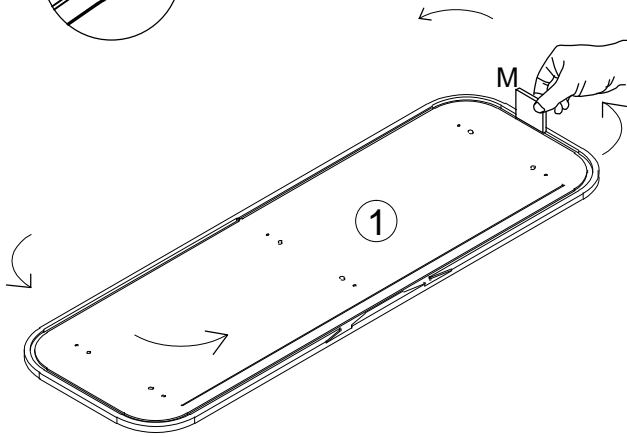
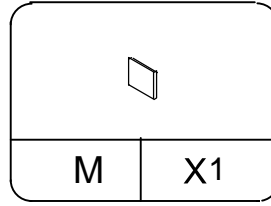
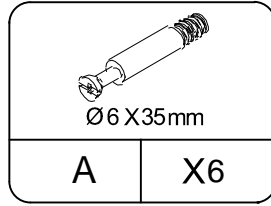
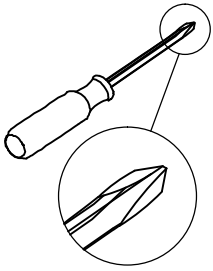

In order to make the sliding door smoother, please first lubricate the groove of panel () with wax block (M).



Please apply as much wax as possible. The more wax you apply, the smoother the door will move.

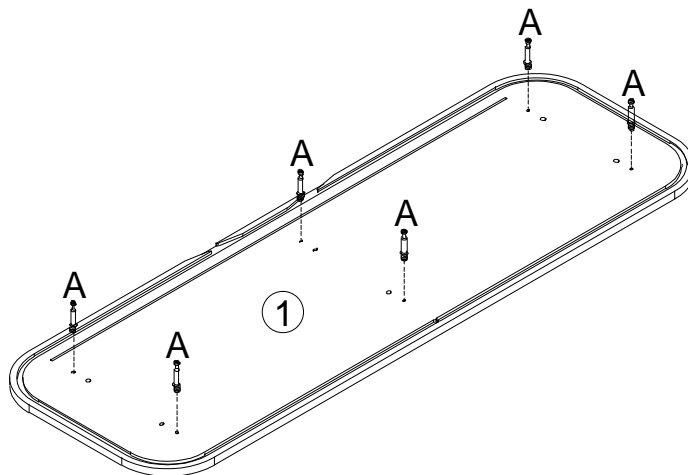

STEP 2

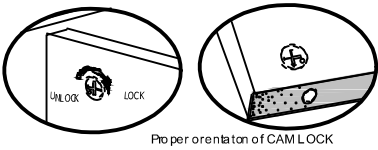
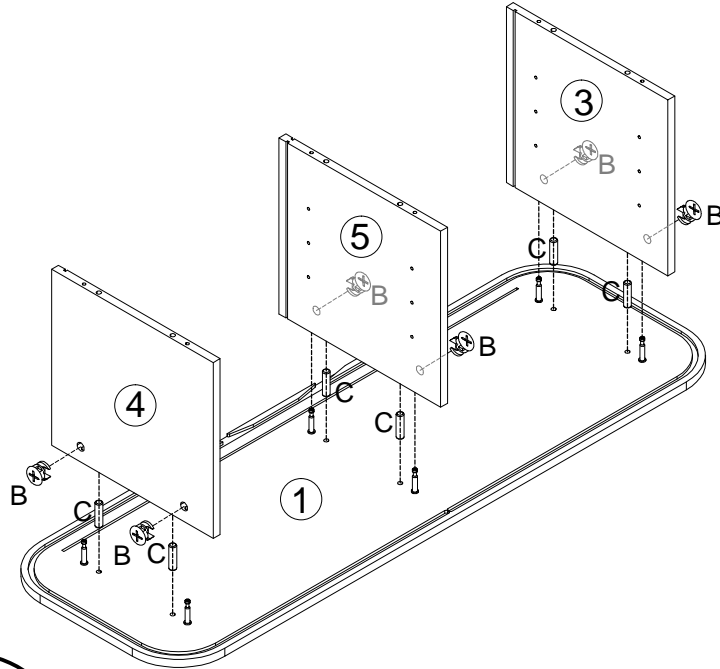
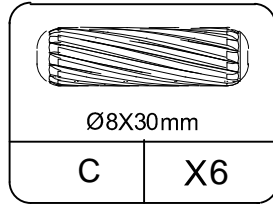
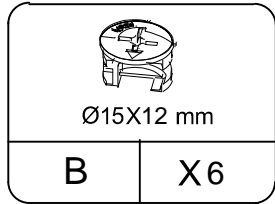
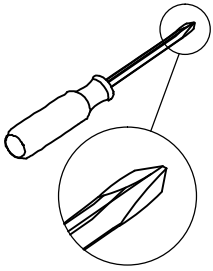

Note the position of the round hole on the back panel(6).

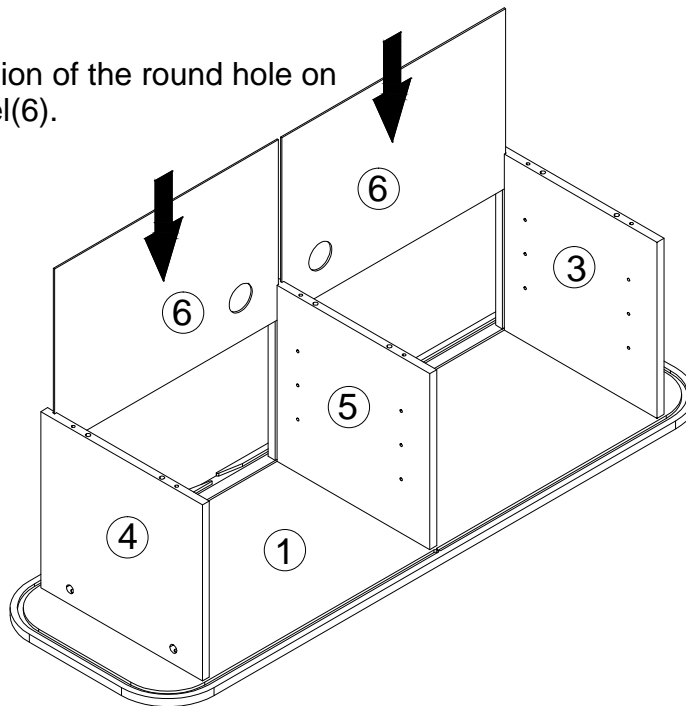

STEP3

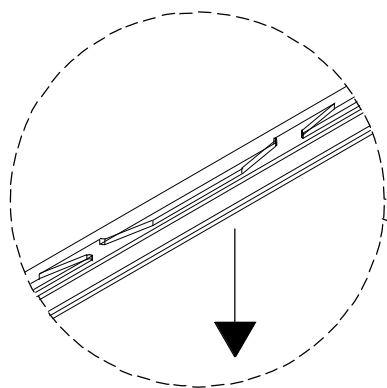
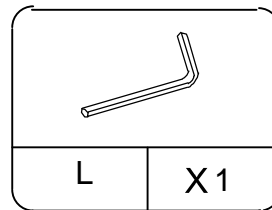
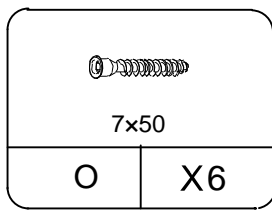
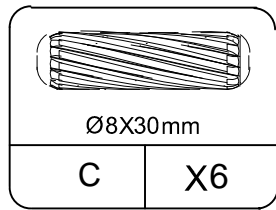

Note the front and rear directions of panel(2).

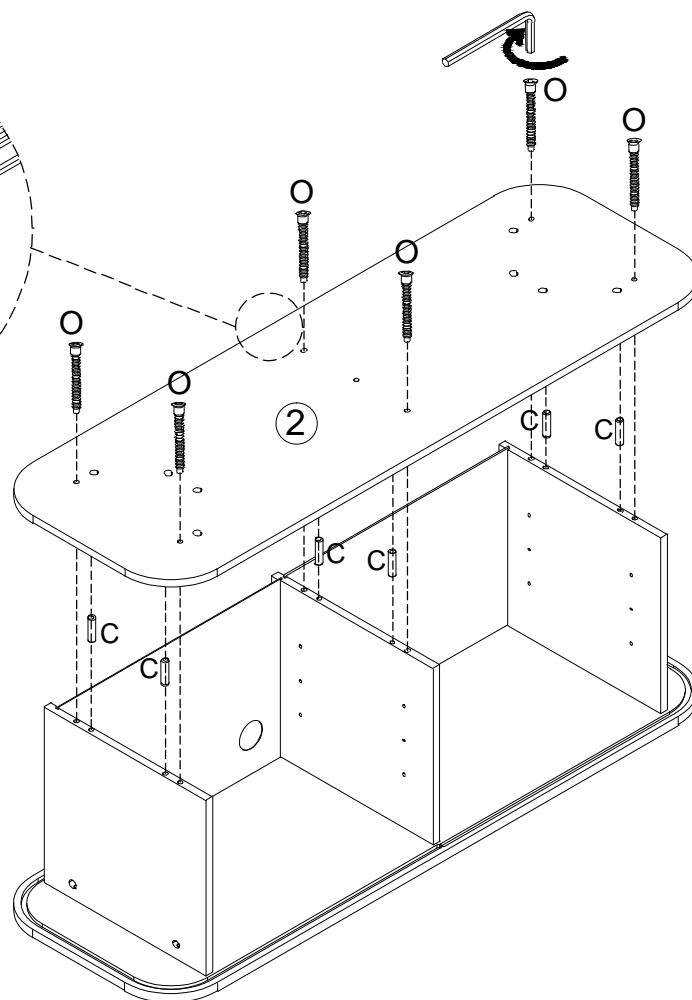

STEP 4

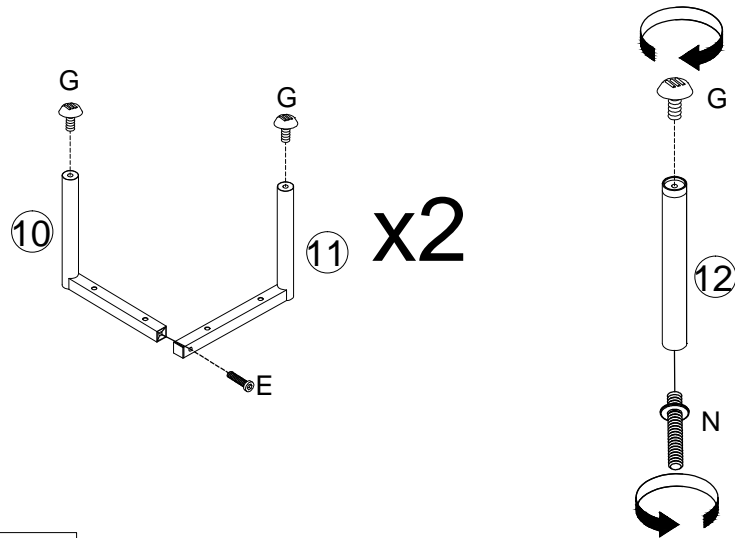
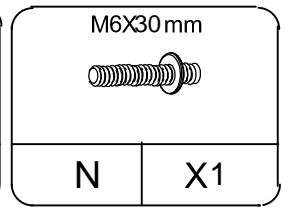
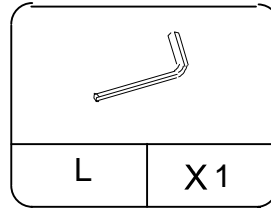
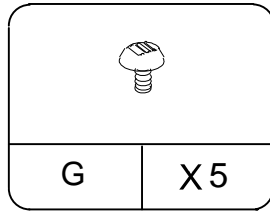
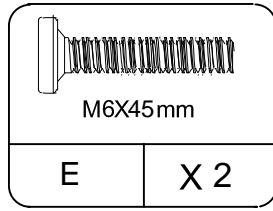
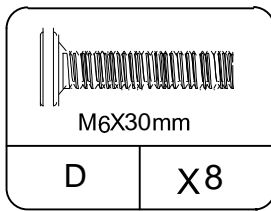

Please tighten the bolts to 80% first, and tighten all bolts 100% after all parts are assembled.

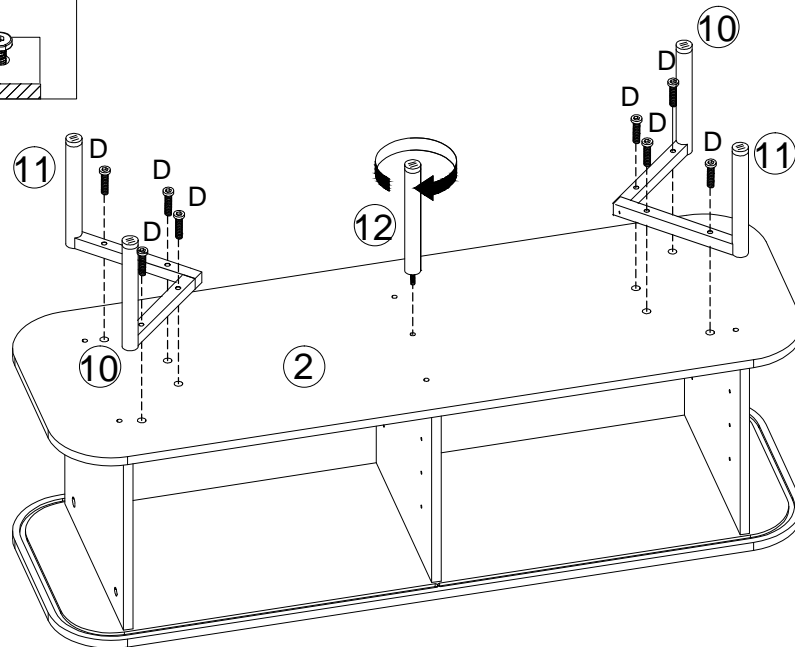

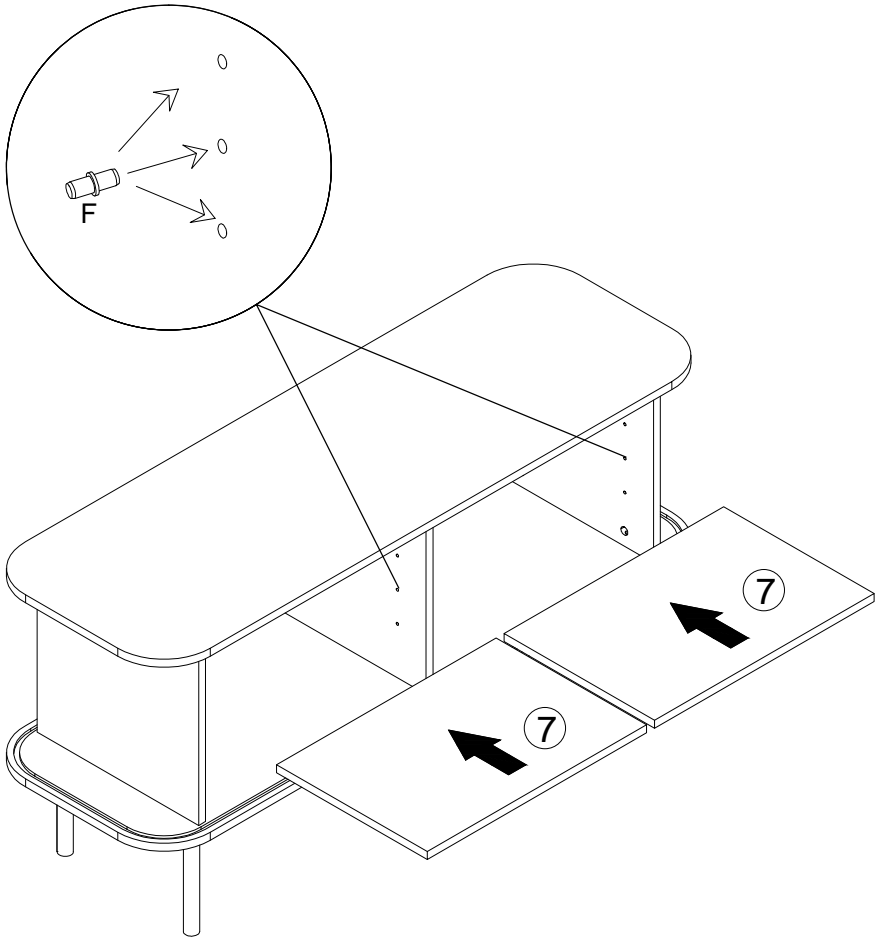
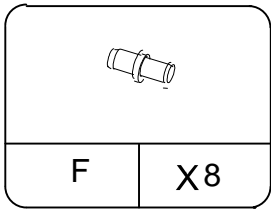

STEP5

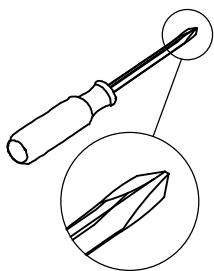

STEP 6



			
I	X2	K	X4

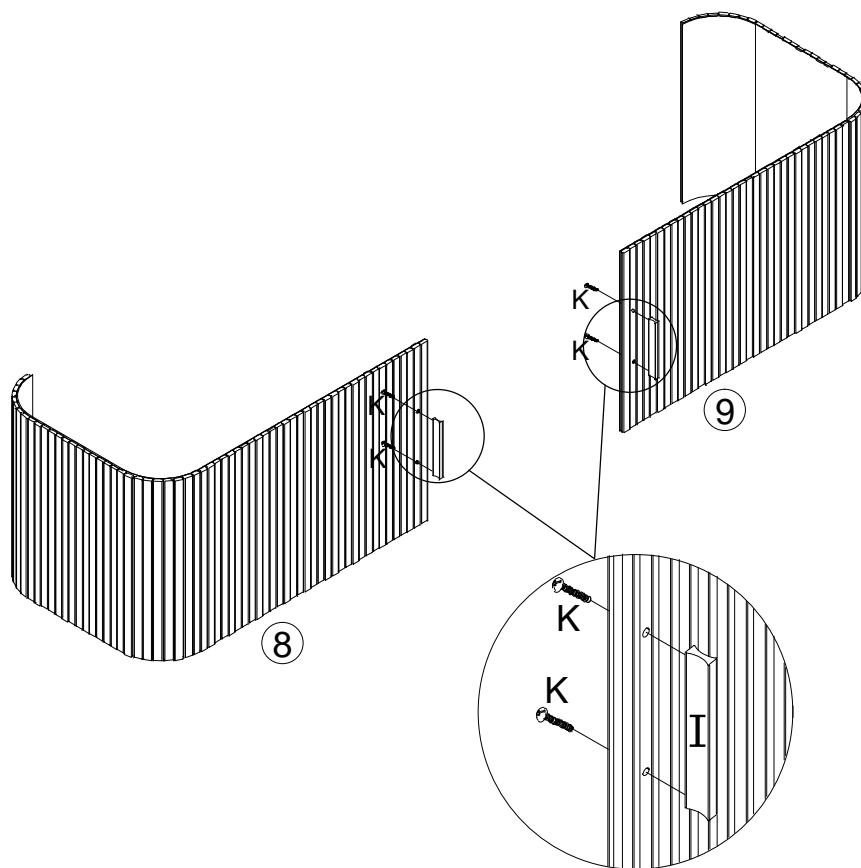

STEP 7

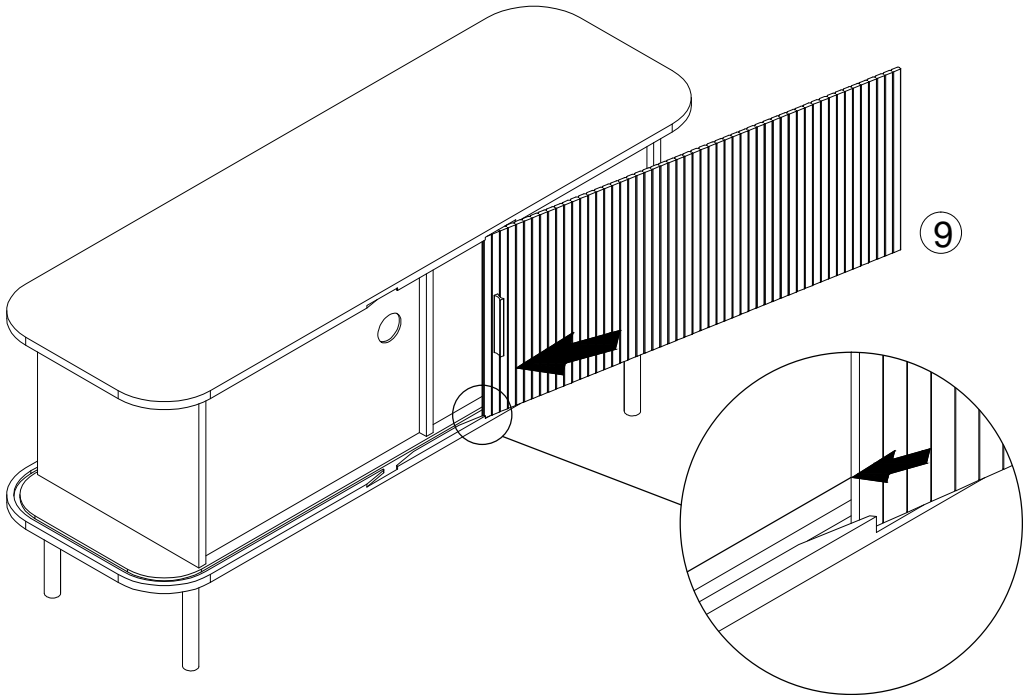
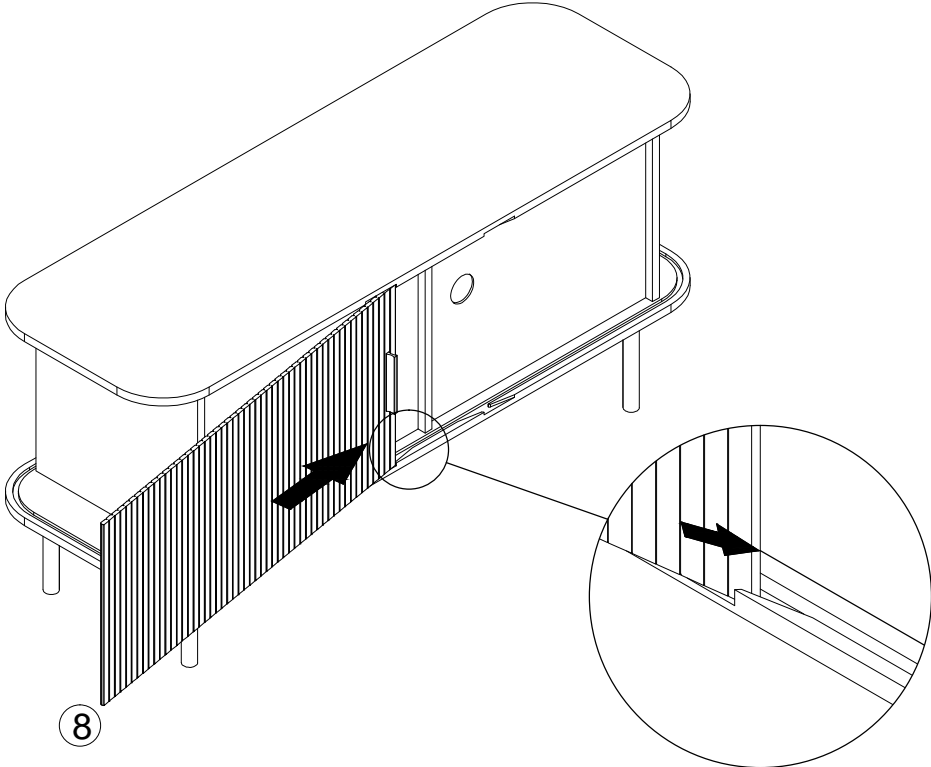

STEP 8

