

TV Table

Using an electric drill can speed up installation, but it requires reducing the torque of the drill .

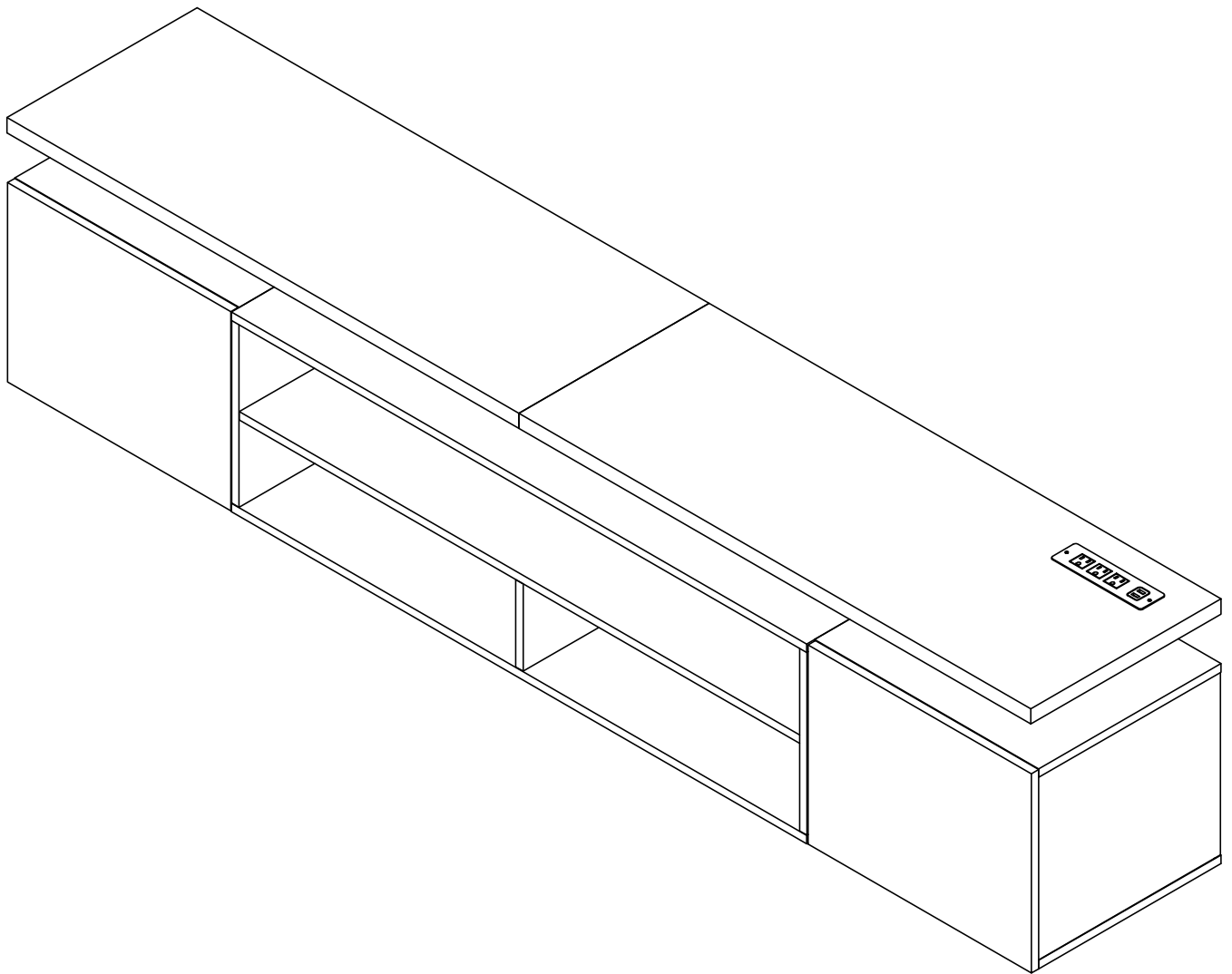

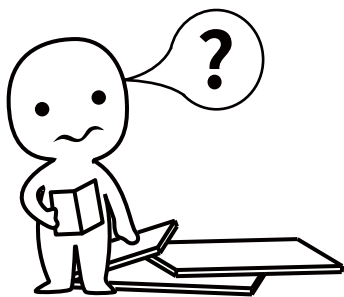

IMPORTANT INFORMATION!

please read the entire manual before starting to assemble and/or using this product. follow the manual thoroughly and keep it for further reference.

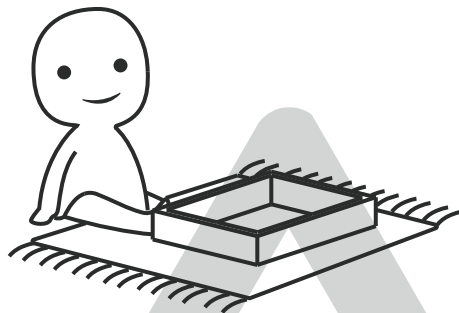
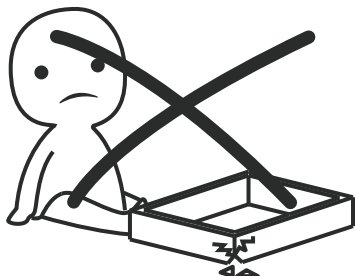

AVOID SCRATCHES!

In order to avoid scratching this furniture should be assembled on a soft layer—could be a rug.

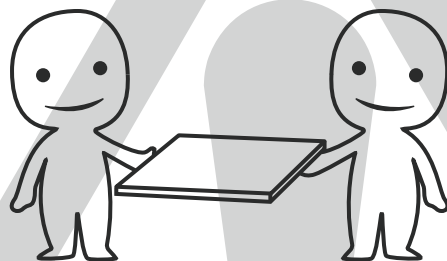

IMPROVE EFFICIENCY !

Try to find a partner to install with you, which can speed up the installation efficiency and shorten the time.

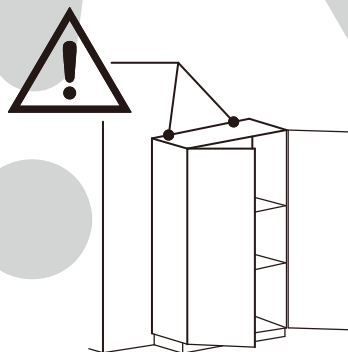
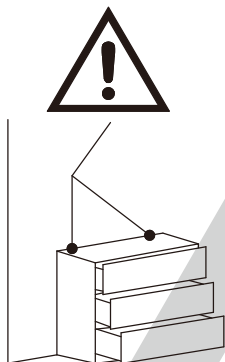

ANTI-TOPPLE WARNING !

Overtipped furniture can cause serious or fatal crush injuries. To prevent tipping over, be sure to use the wall attachment, if not included with this product. Please purchase the wall attachment that fit your wall. If unsure, seek professional advice. Please read and follow each step of the instructions carefully.

IMPORTANT !

It is important that any product which is assembled using any kind of screw is re-tightened 2 weeks after assembly, and once every 3 months - in order to assure stability through-out the lifespan of the product.

For regular maintenance and cleaning of the product, for the frame, please use a rag dipped in neutral detergent to fully wipe it, and then dry it with a clean rag. For glass materials, wipe with a rag dampened with water glass cleaner, and then dry with a dry rag.

Do not use an electric screwdriver, and do not use too much force when installing, because the board is easy to break.

Board Identification

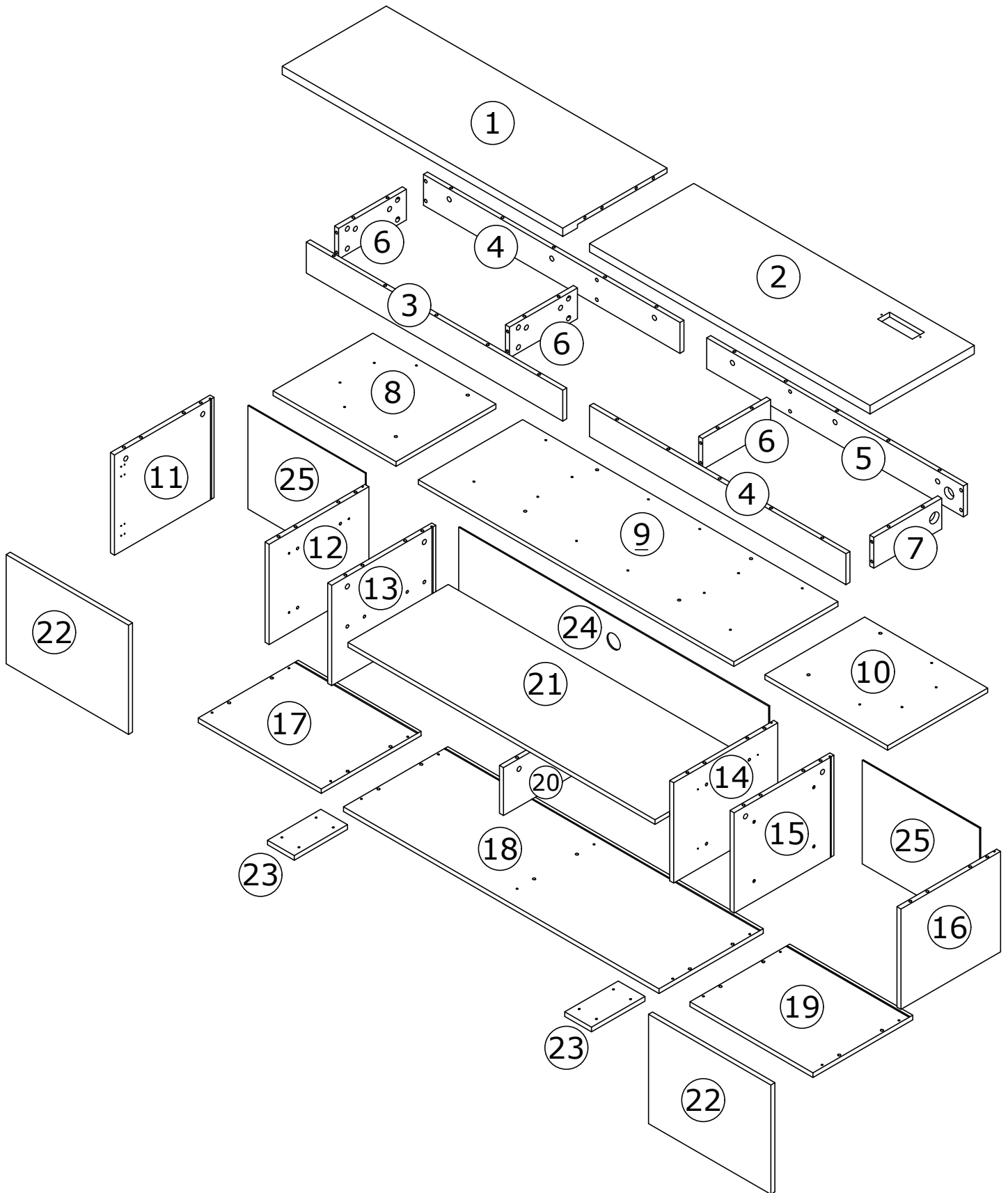

PARTS LIST

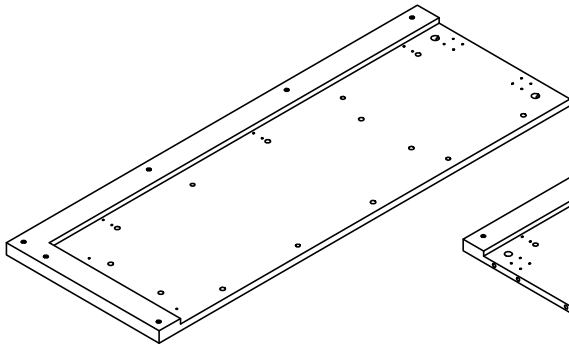

①

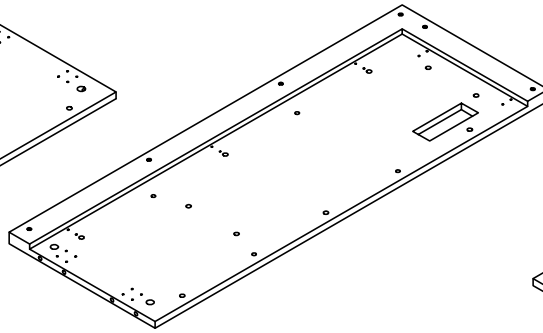

②

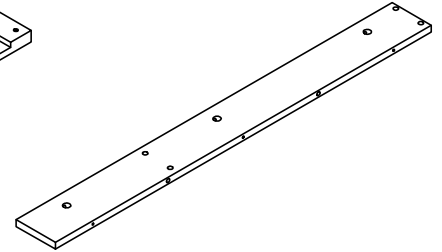

③

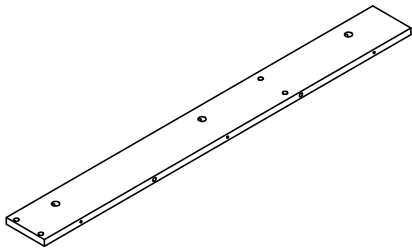

④ X2

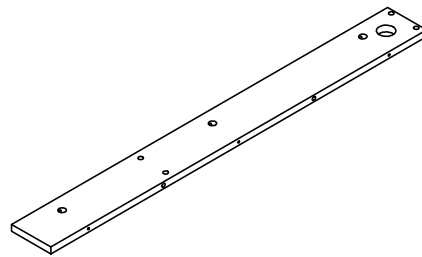

⑤

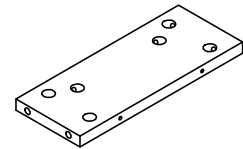

⑥ X3

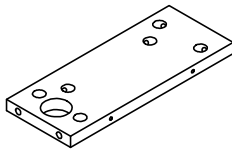

⑦

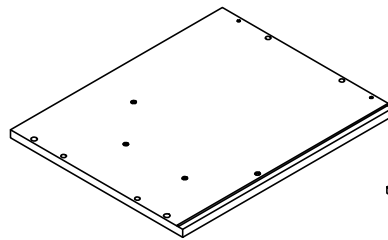

⑧

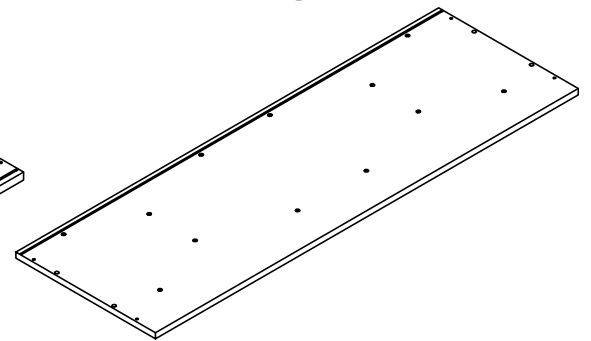

⑨

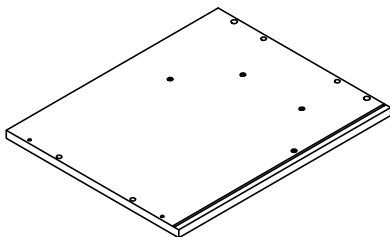

⑩

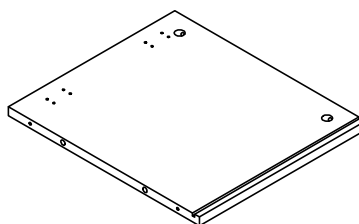

⑪

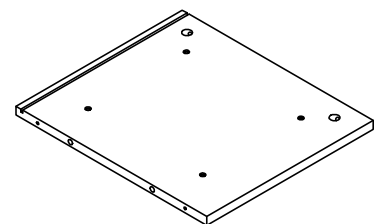

⑫

PARTS LIST

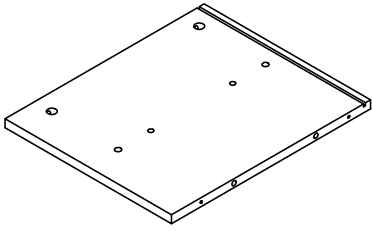

⑬

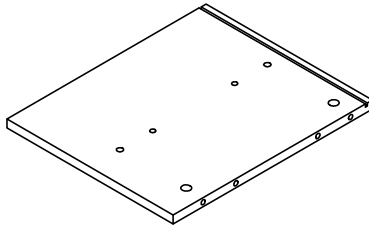

⑭

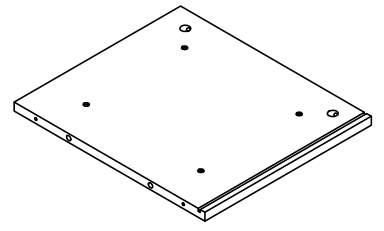

⑮

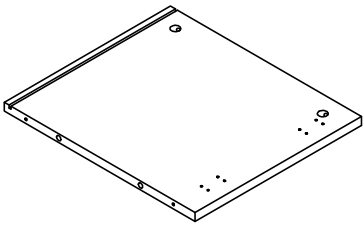

⑯

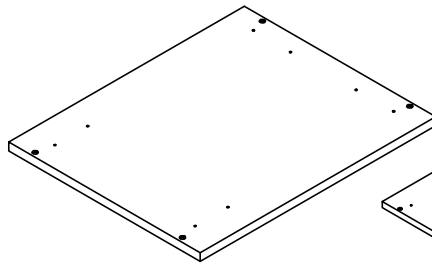

⑰

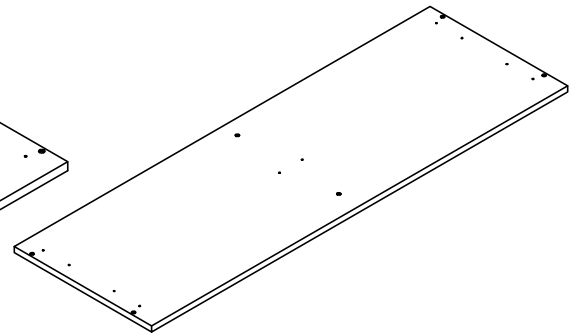

⑱

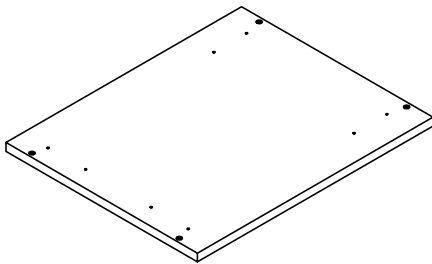

⑲

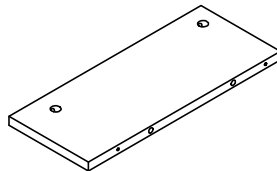

⑳

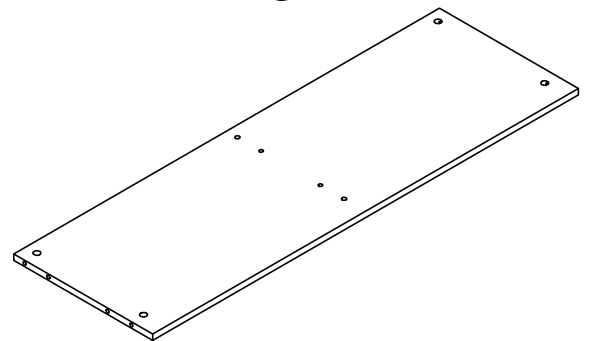

㉑

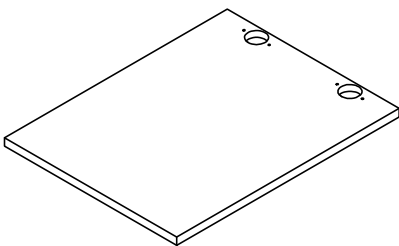

㉒ X2

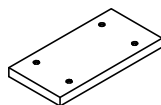

㉓ X2

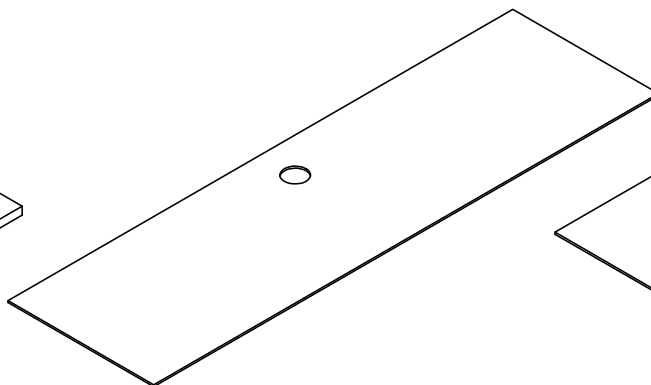

㉔

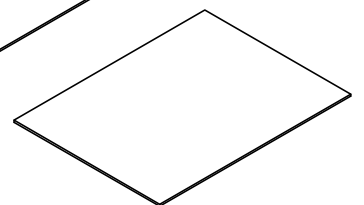

㉕ X2

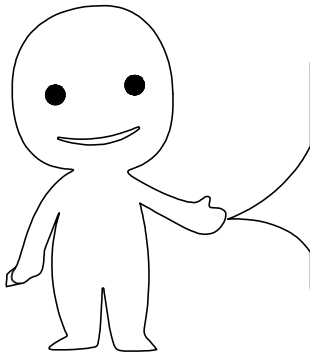

Please prepare the following tools

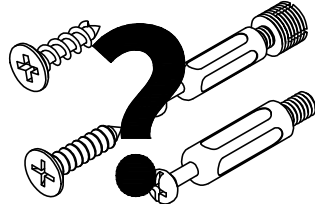
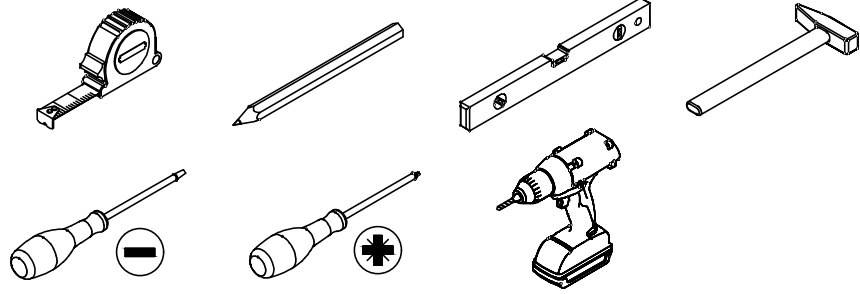

When installing, please carefully confirm whether each screw corresponds to the manual, accessories with similar shapes can be distinguished by size

A x 58



Ø 15 x 11.5 mm

B x 46

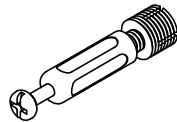

Ø 7 x 40 mm

C x 50

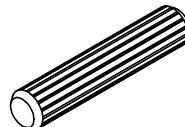

Ø 8 x 40 mm

D x 40

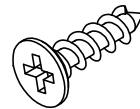

Ø 3.5 x 14 mm

E x 34

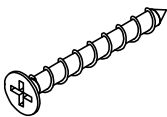

Ø 4 x 25 mm

F x 9

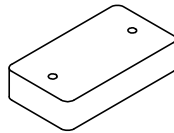

G x 4

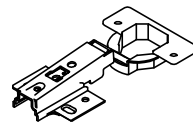

H x 34

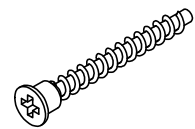

Ø 5 x 40 mm

I x 1

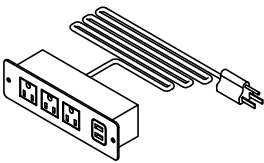

J x 26

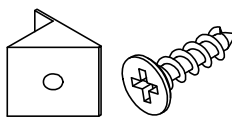

J-1 J-2

M x 2

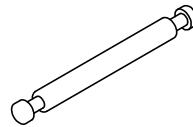

Ø 6 x 74 mm

L x 8

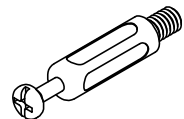

Ø 7 x 40 mm

N x 2

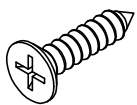

Ø 3.5 x 14 mm

O x 8

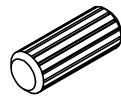

Ø 8 x 20 mm

P x 14

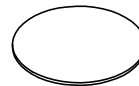

+2

SPARE BAG

K x 1

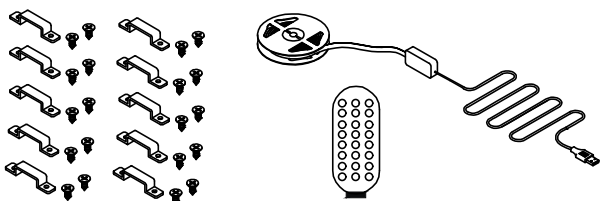

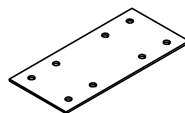

Q x 2

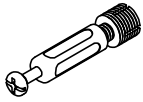
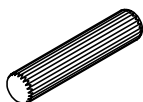
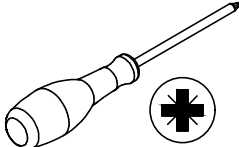

1

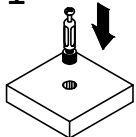
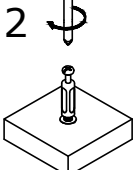
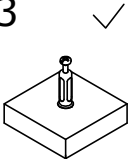
<p>B x 20</p>  <p>Ø7 x 40 mm</p>	<p>C x 2</p>  <p>Ø8 x 40 mm</p>	
---	--	---

	<p>1</p> 	<p>2</p> 	<p>3</p> 
---	--	--	--

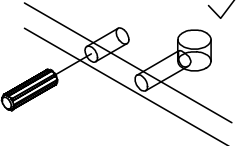
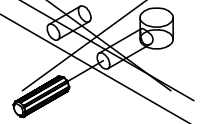
		
---	---	---

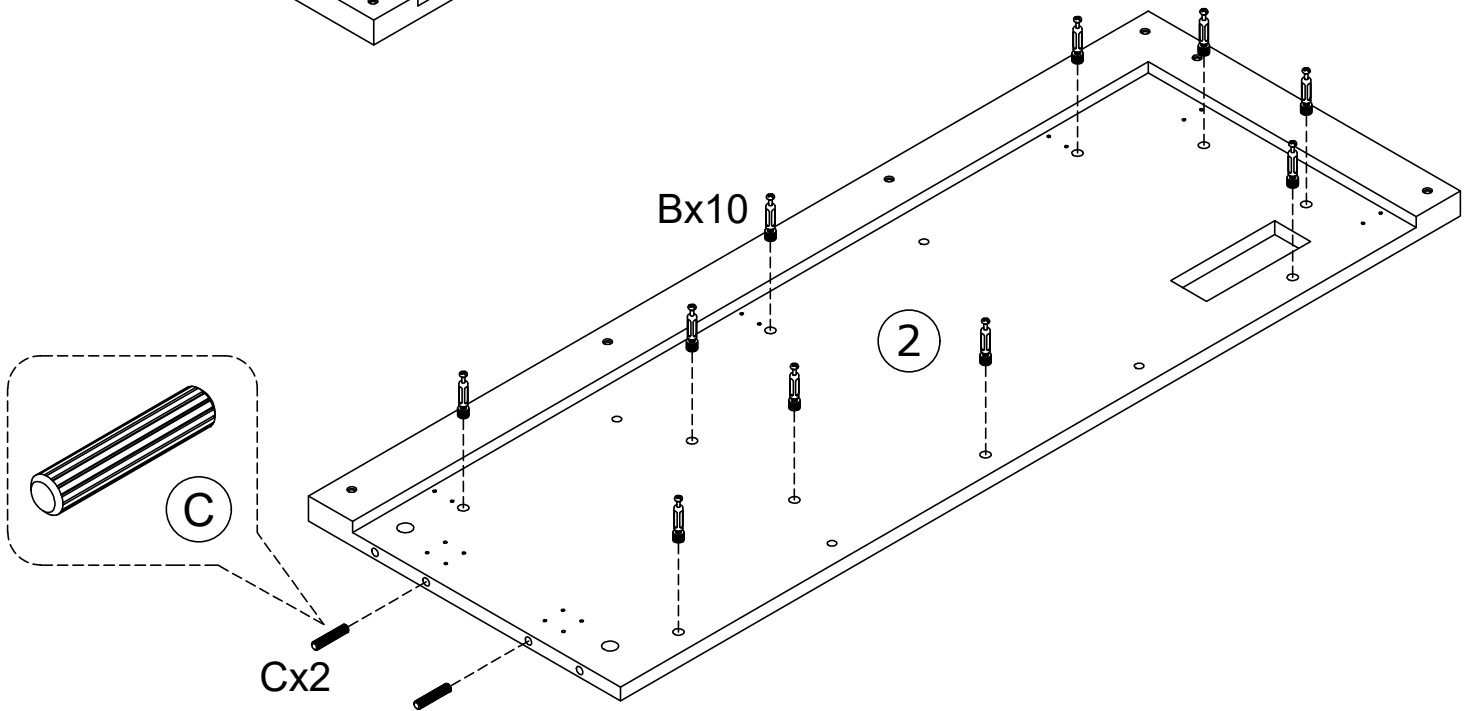
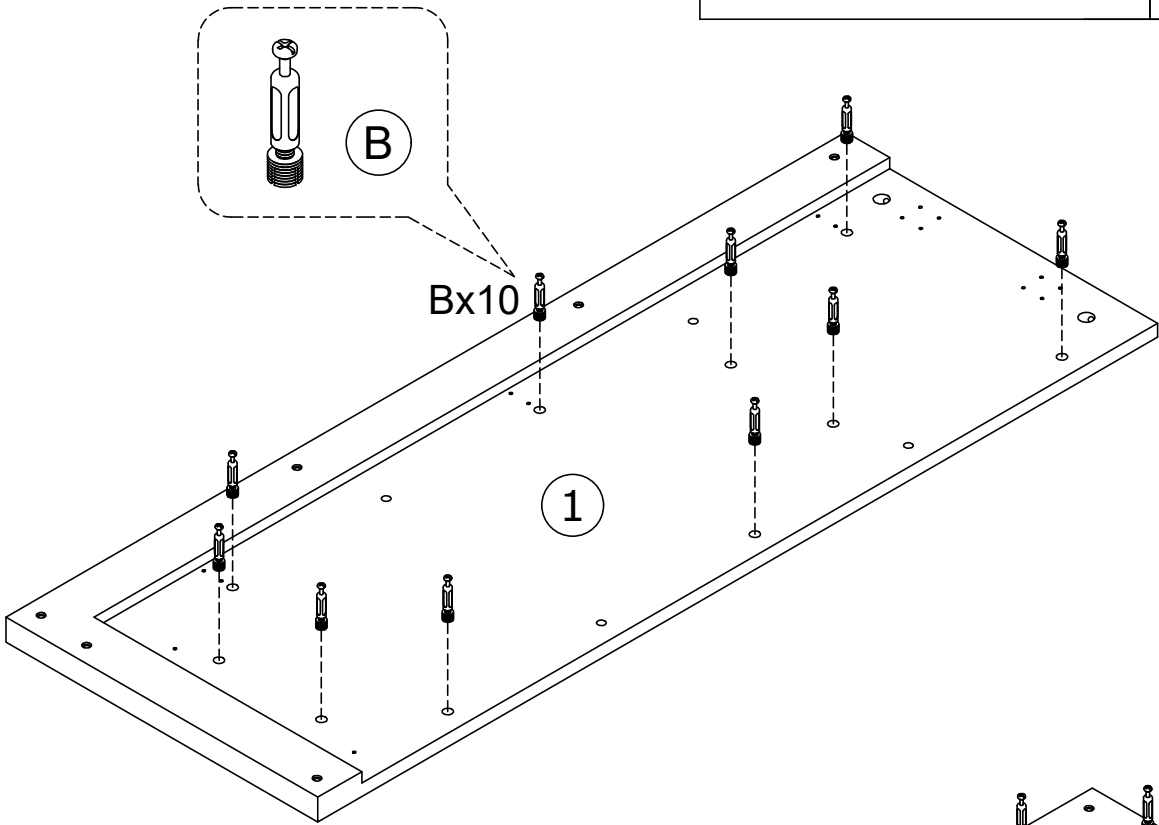

2

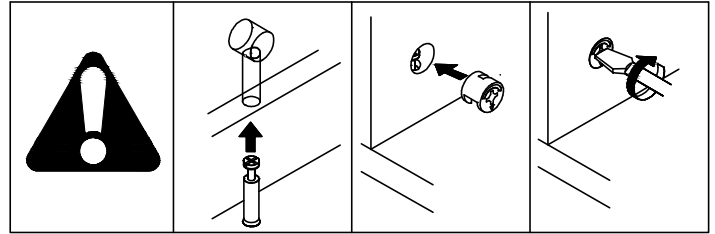
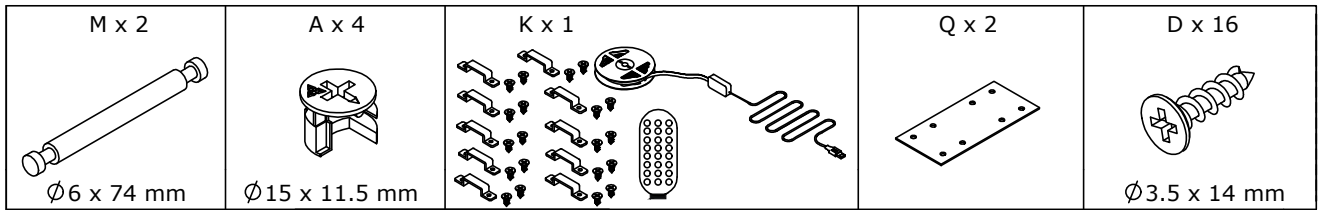

Firstly, evenly place #M into both side holes, and then insert #A into the holes. Simultaneously and evenly tighten both sides of #A.

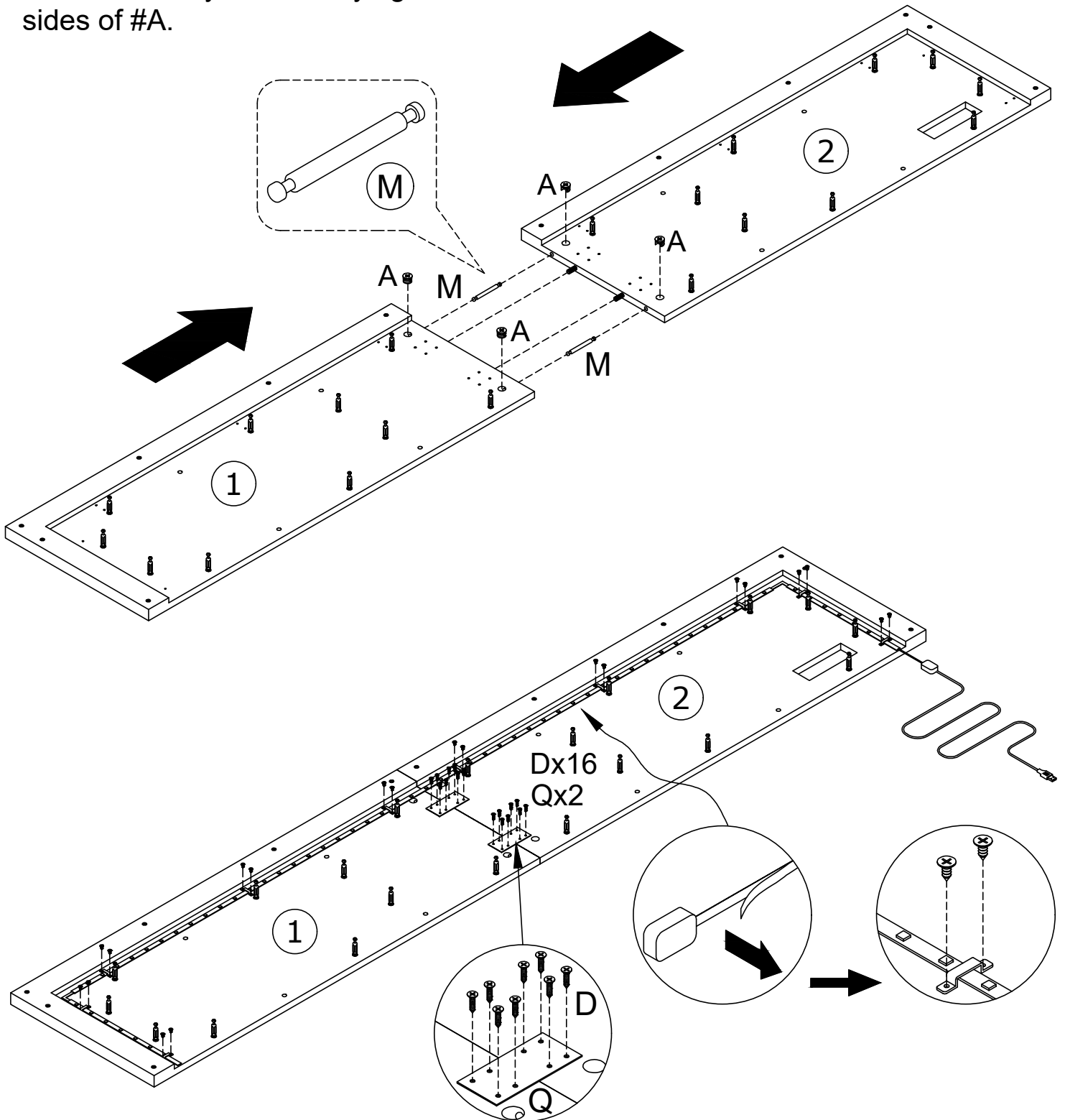

3

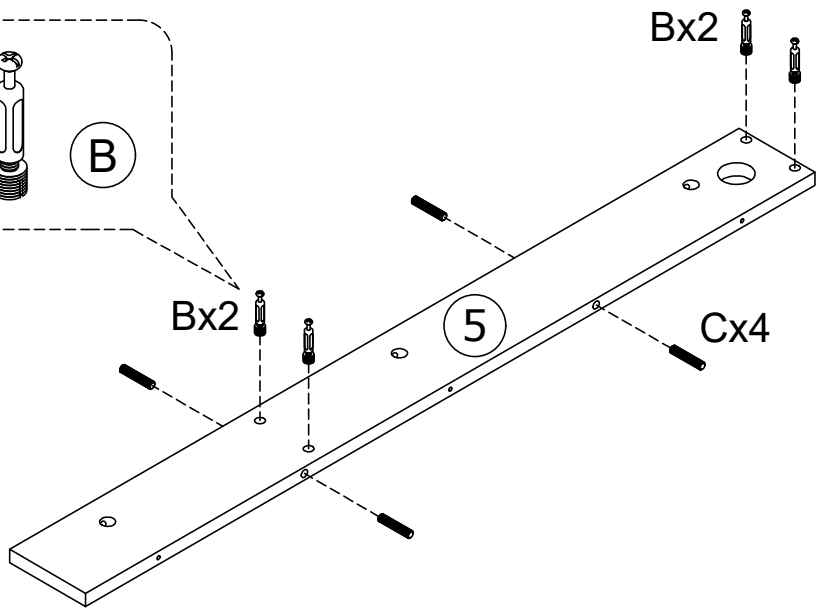
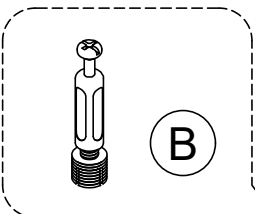
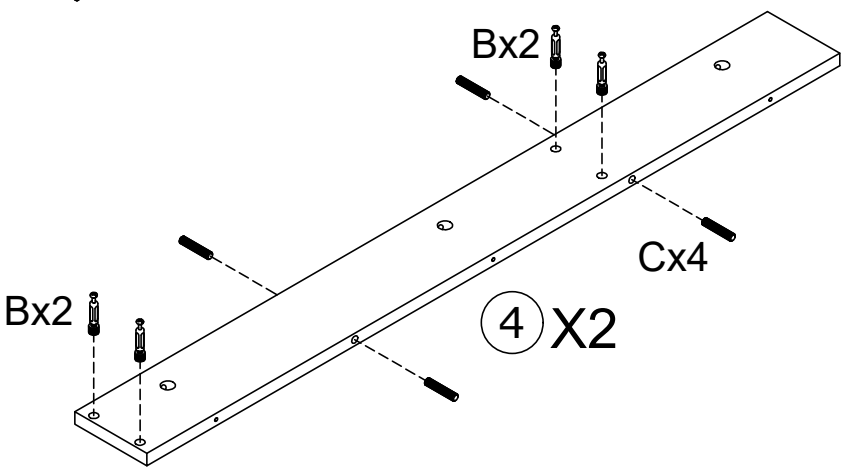
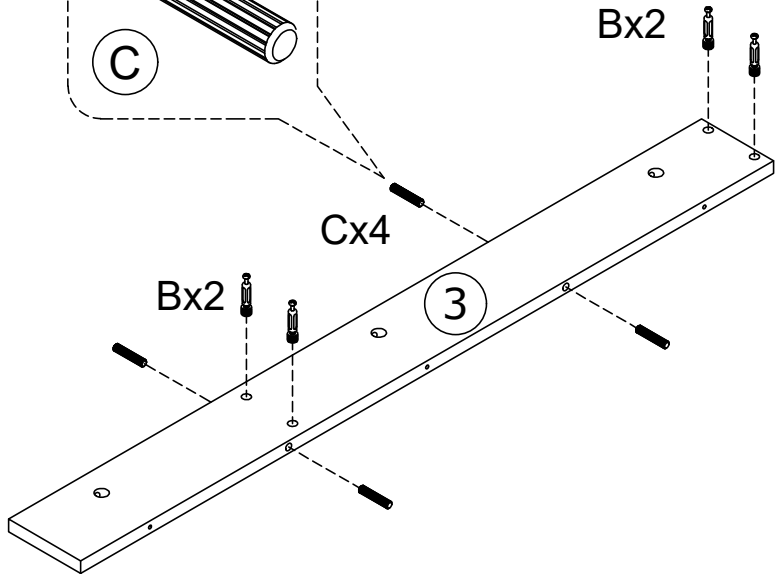
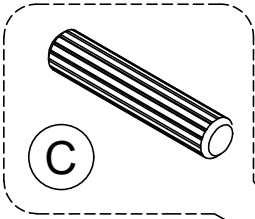
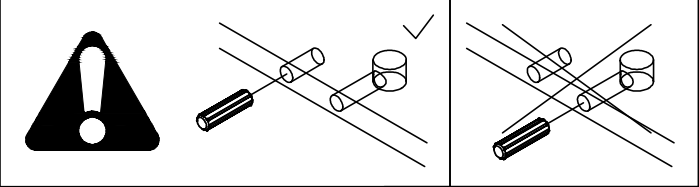
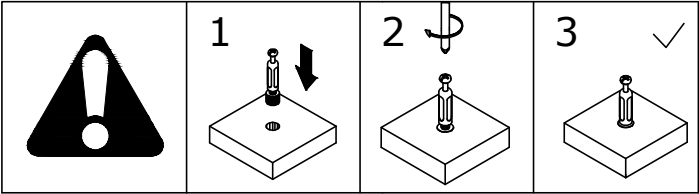
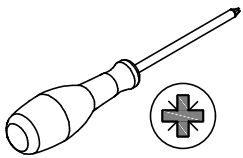
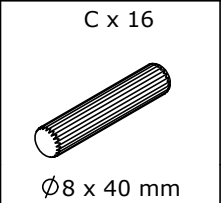
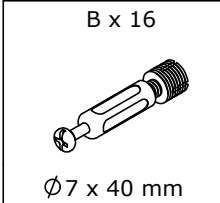

4

A x 16
Ø15 x 11.5mm

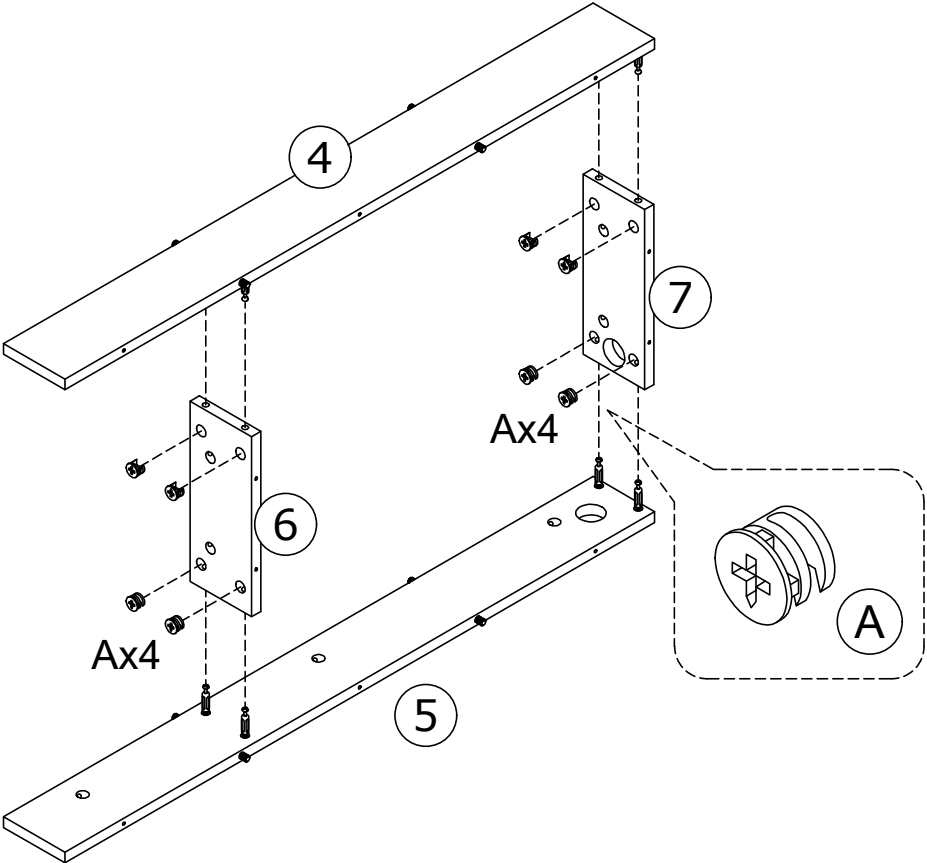
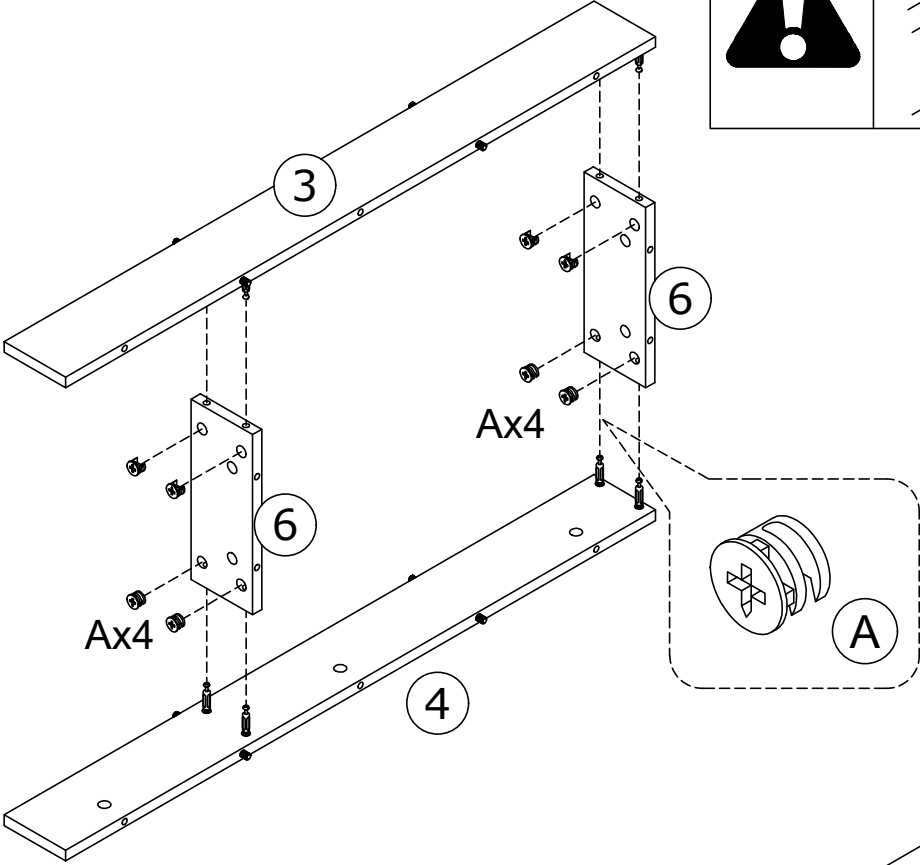
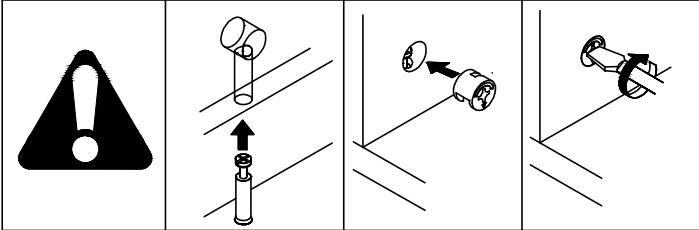
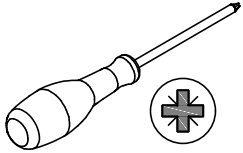

5

A x 20
Ø15 x 11.5mm

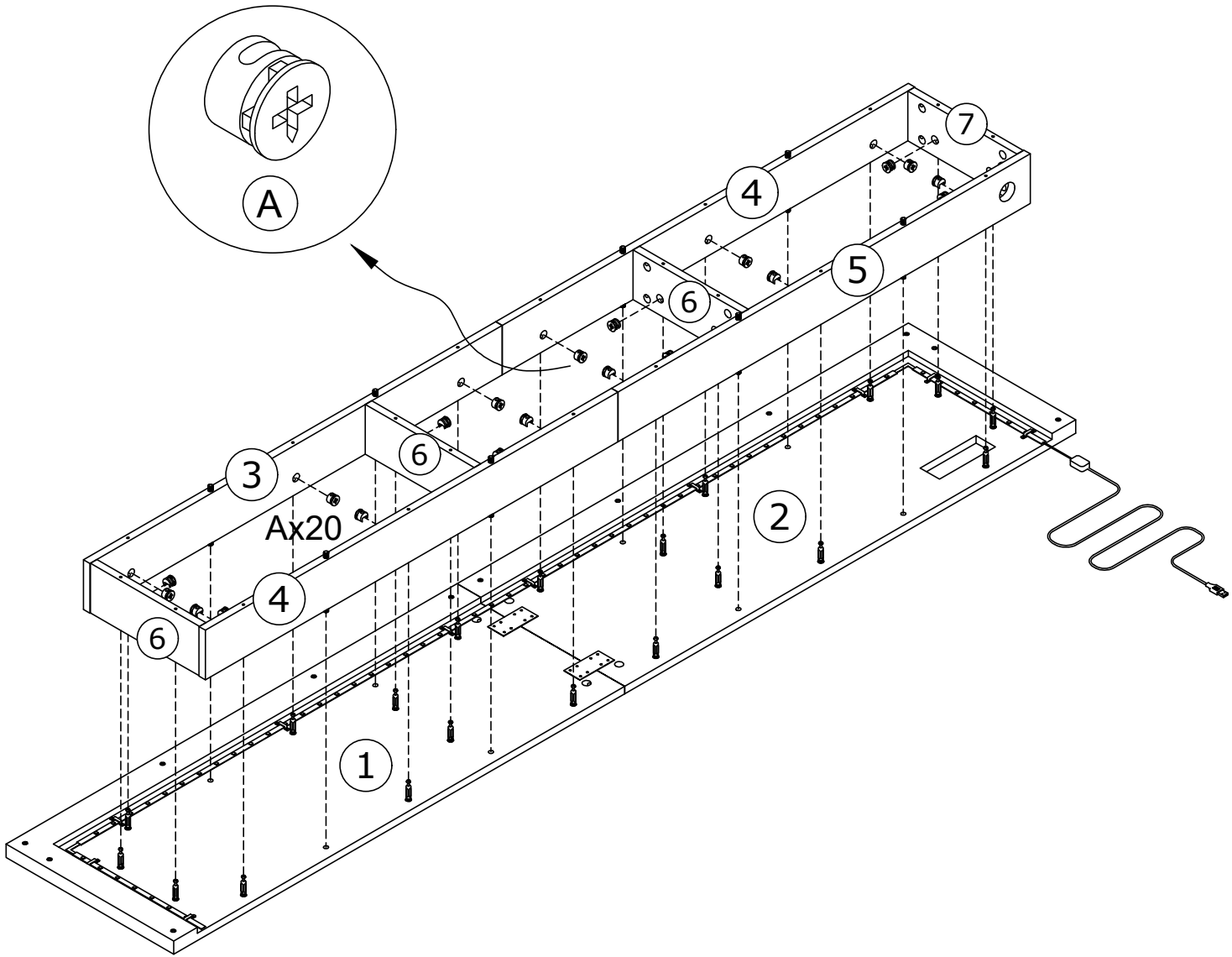
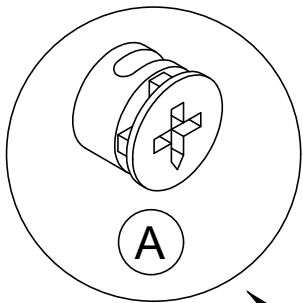
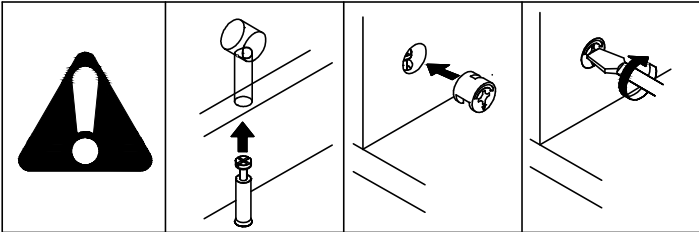
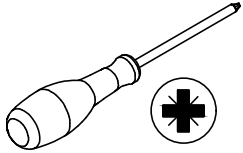

6

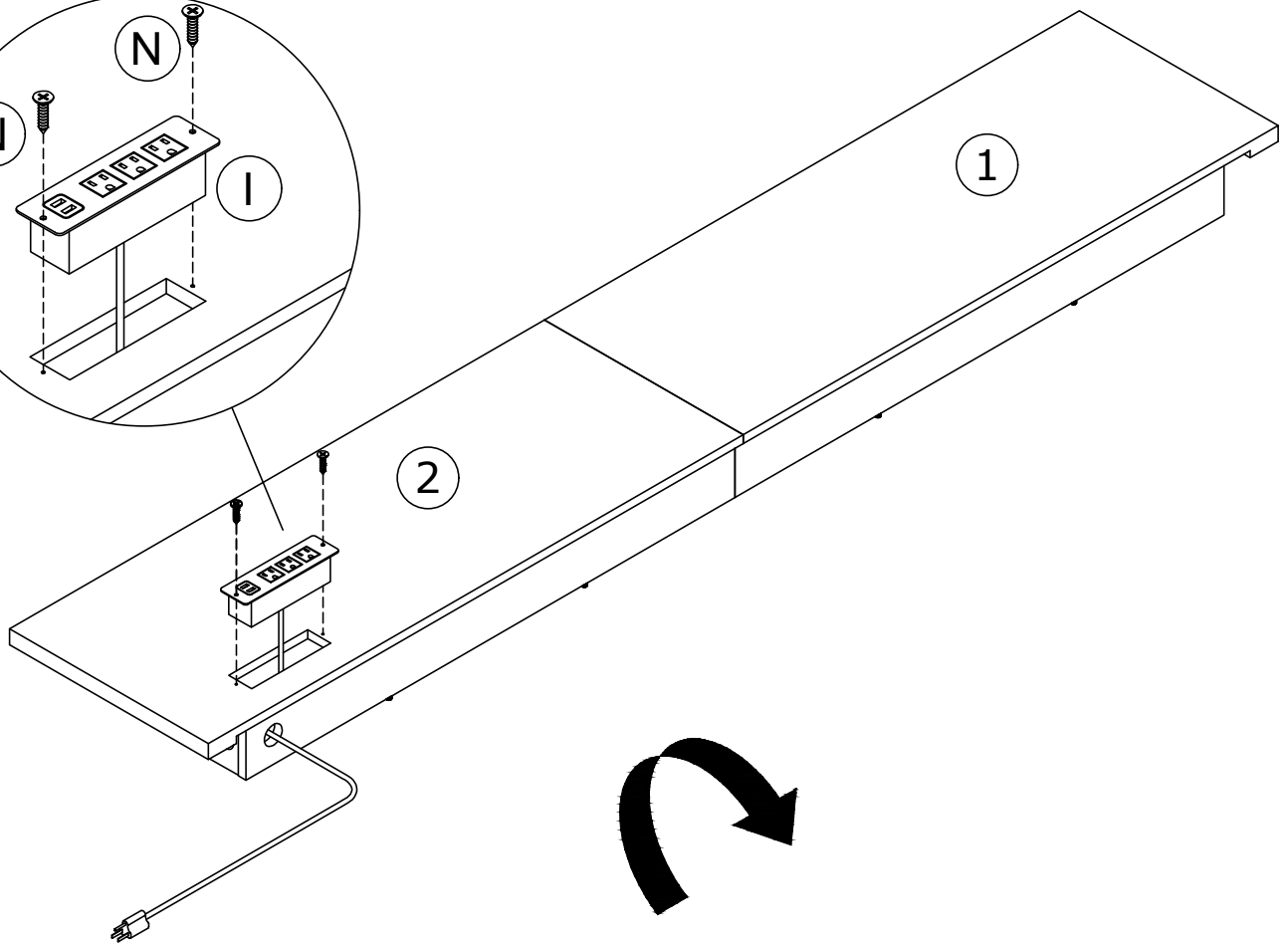
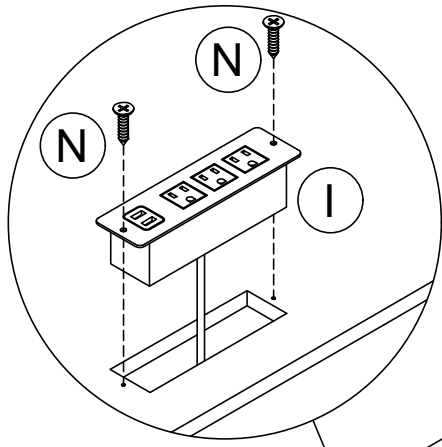
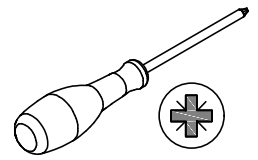
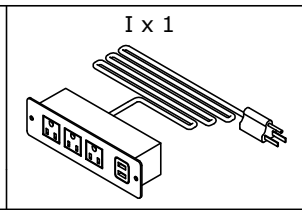
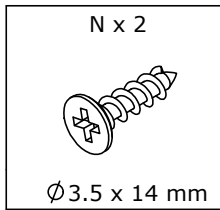

ROTATE 180°

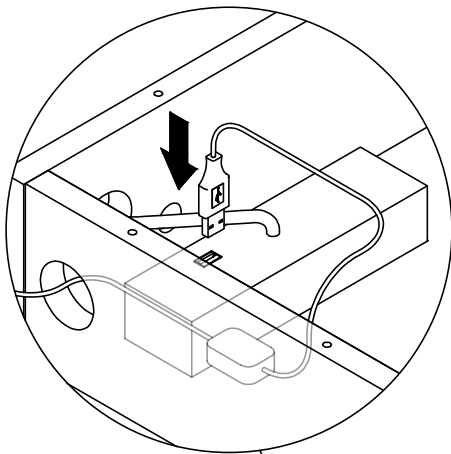

Insert the LED light strip into the bottom interface of the power strip.

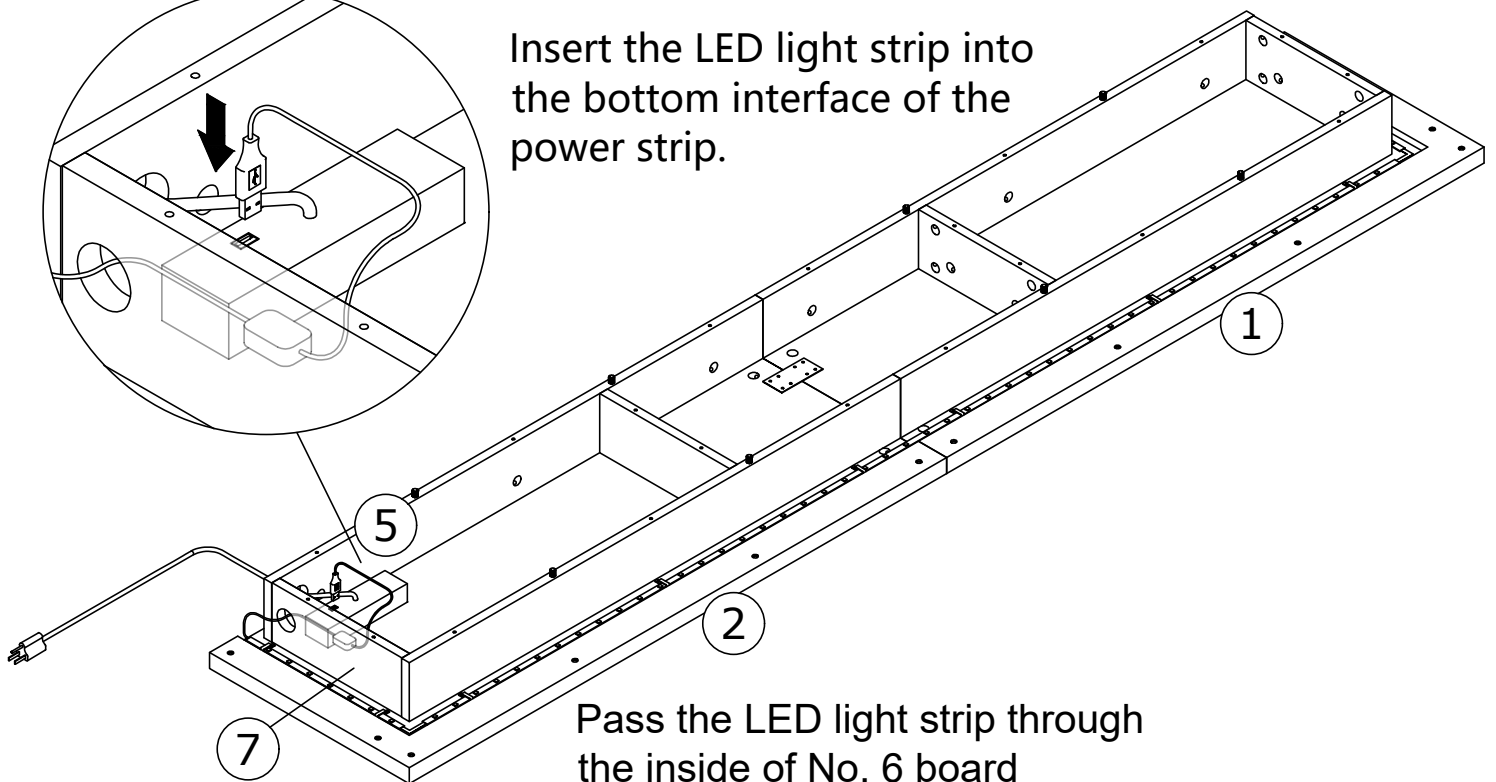

Pass the LED light strip through the inside of No. 6 board

7

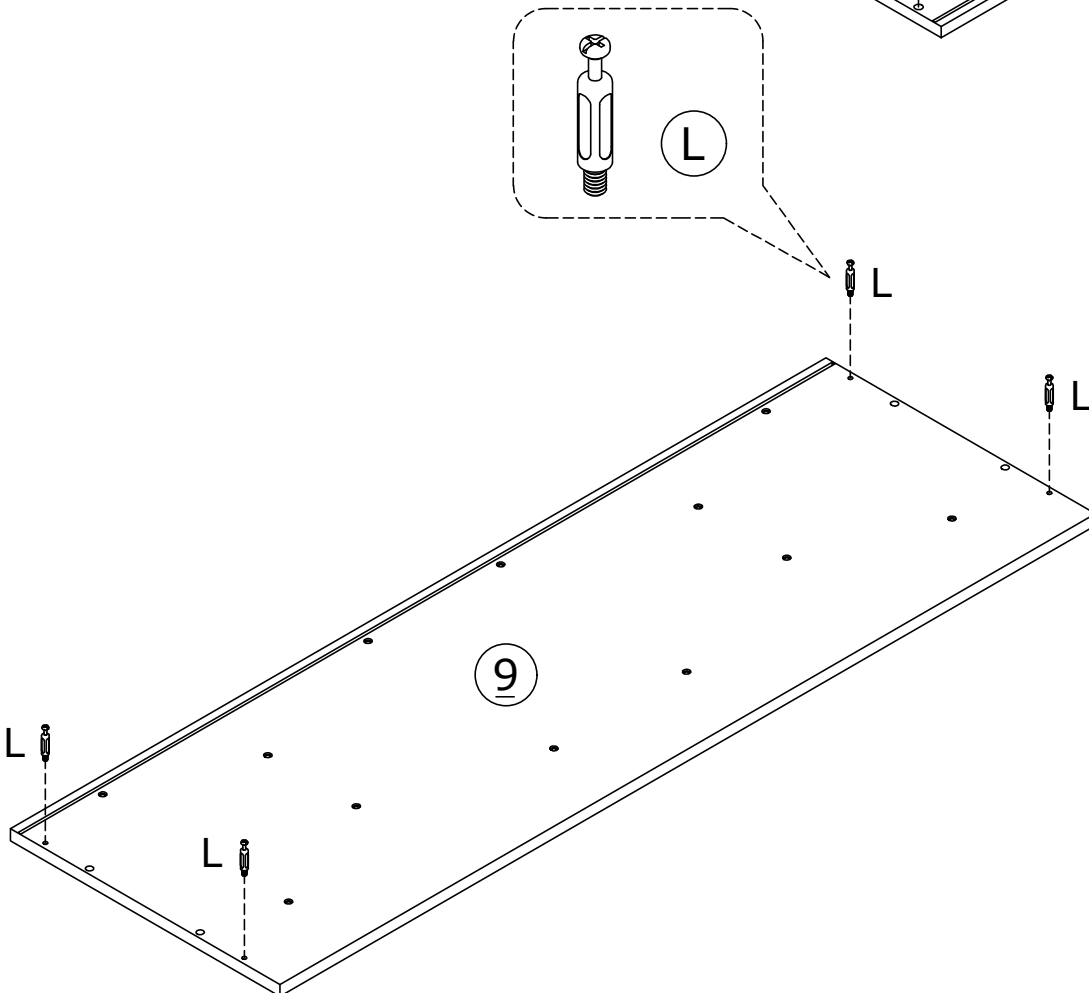
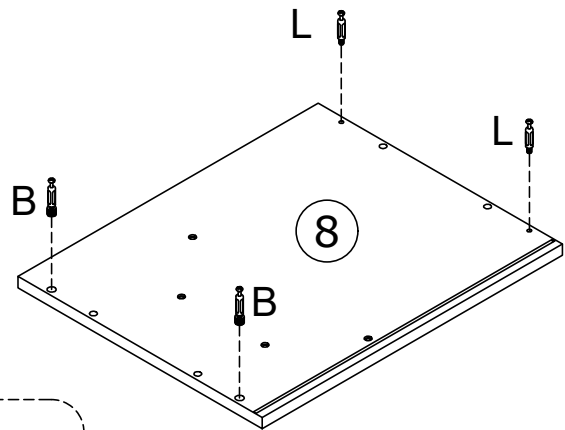
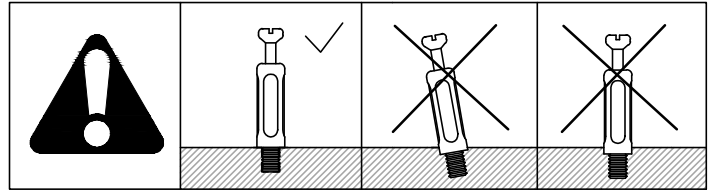
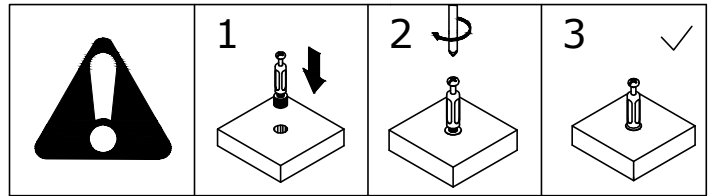
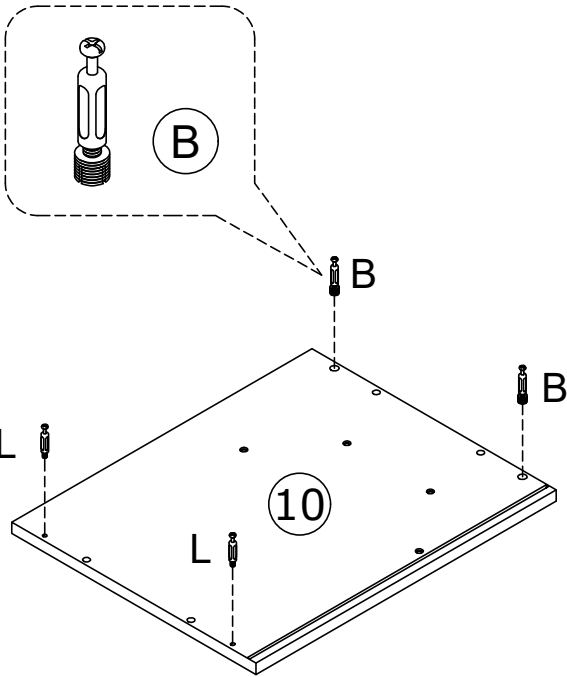
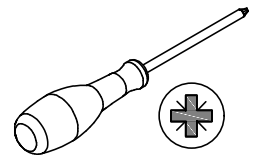
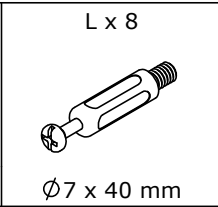
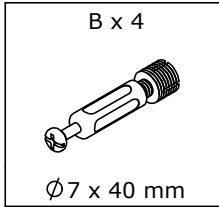

8

H x 20

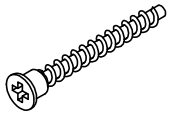

Ø5 x 40 mm

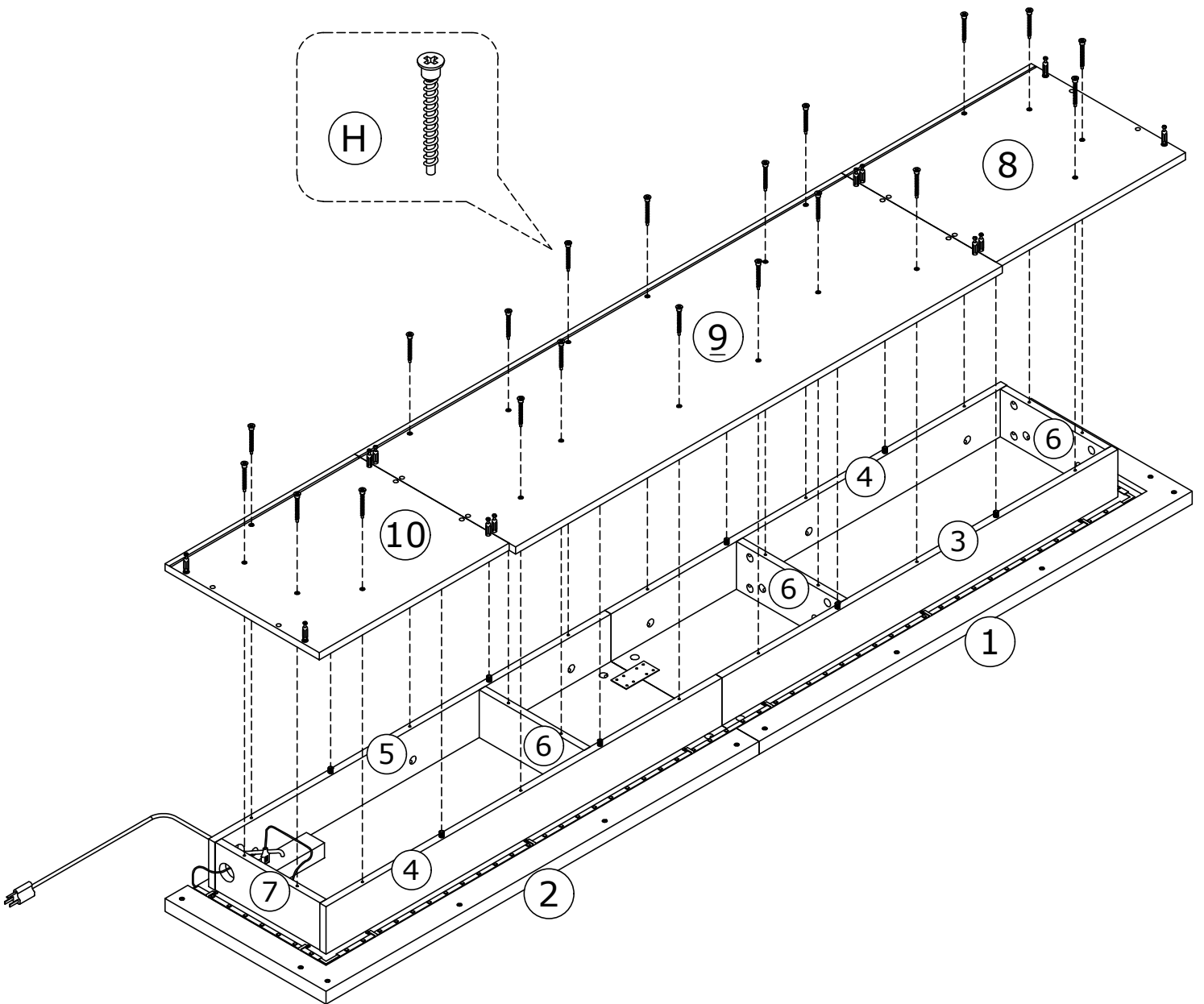
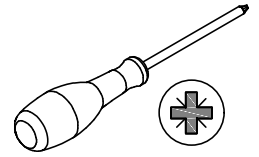

9

C x 20

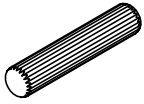

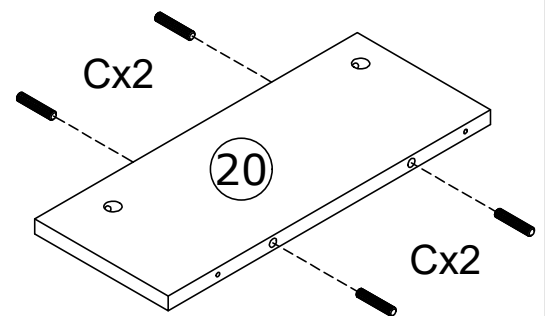
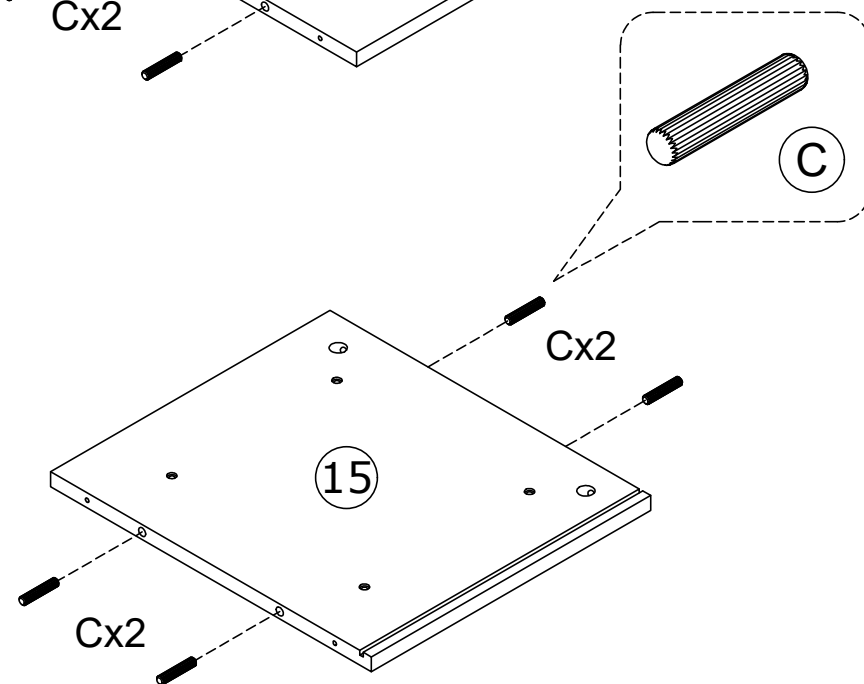
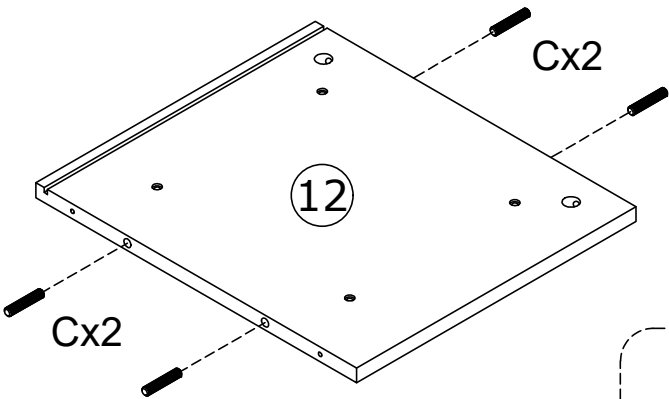
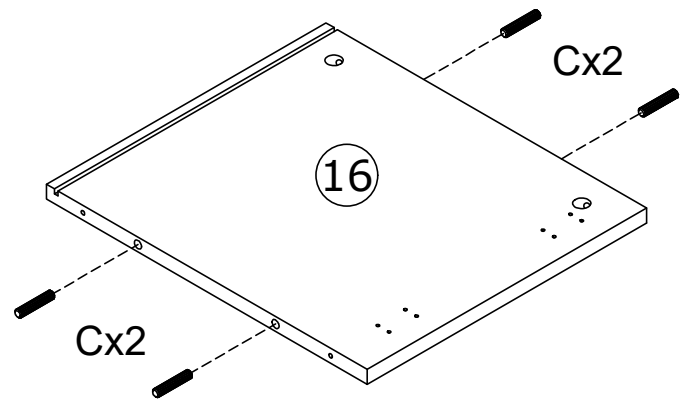
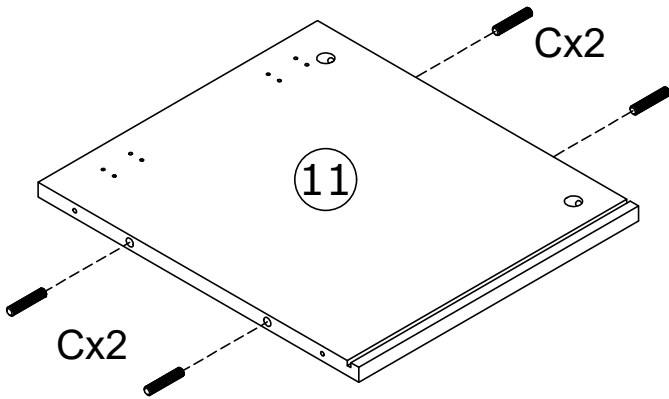
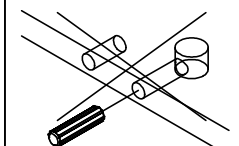
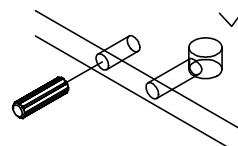
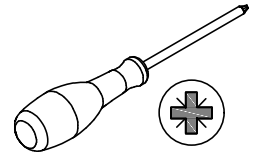

Ø8 x 40 mm

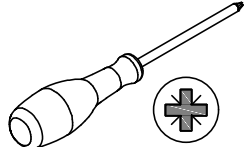

10

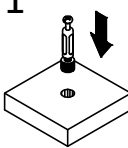
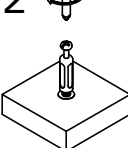
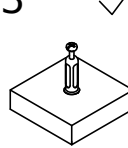
<p>B x 6</p>  <p>Ø7 x 40 mm</p>	<p>C x 12</p>  <p>Ø8 x 40 mm</p>	
--	---	---

	<p>1</p> 	<p>2</p> 	<p>3</p> 
---	--	--	--

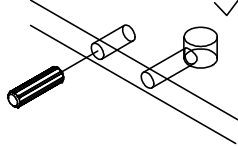
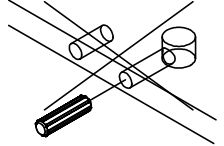
		
---	---	---

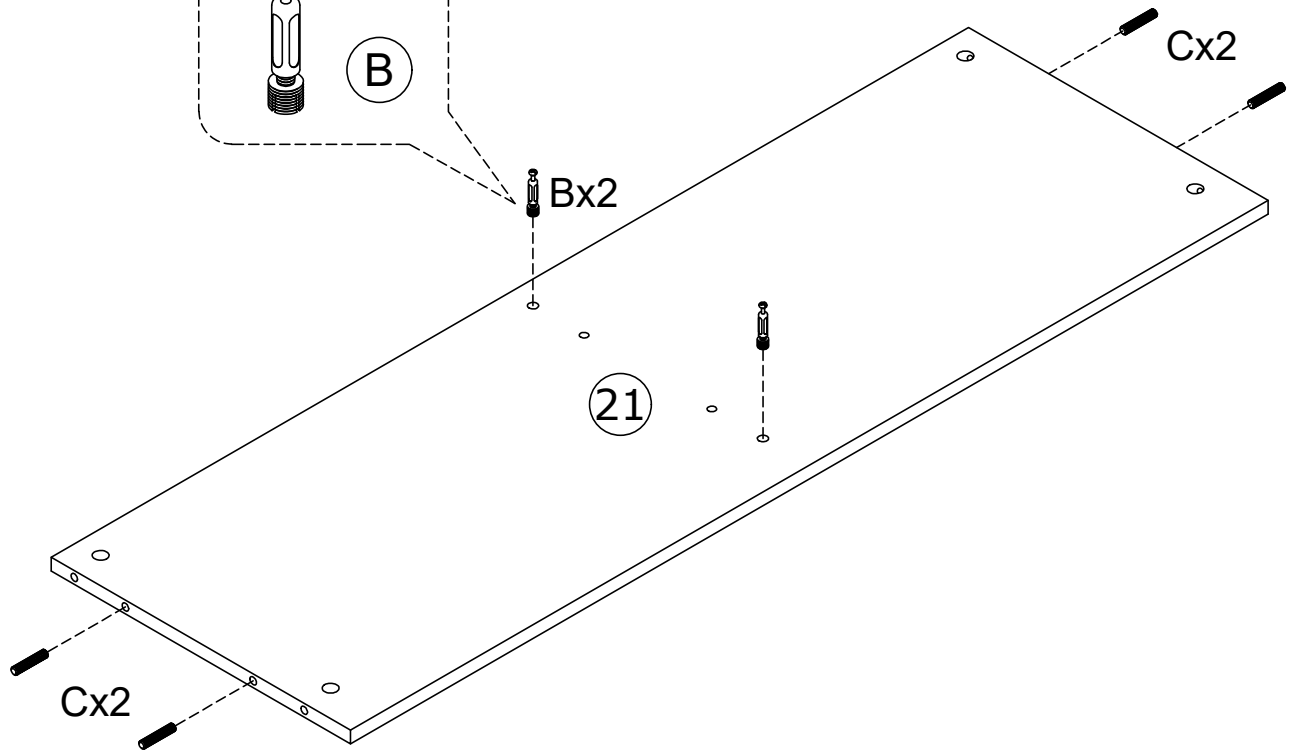
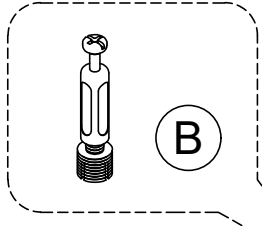
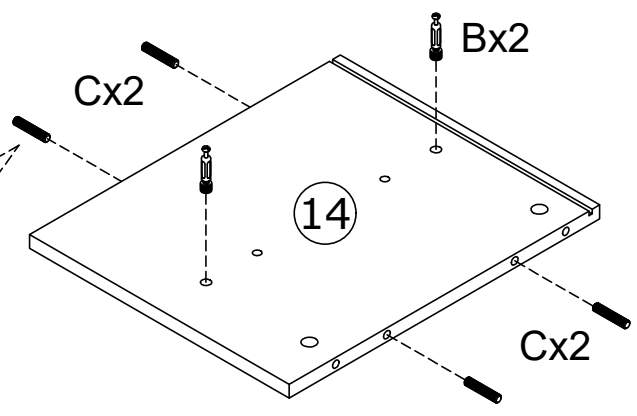
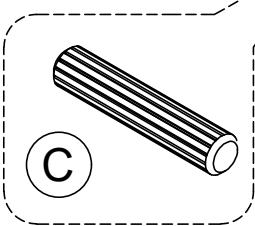
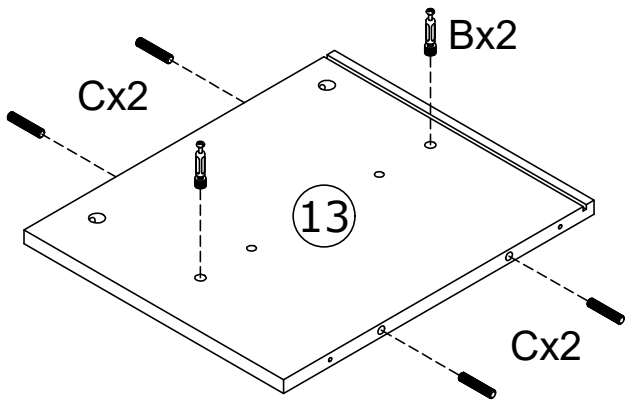

11

A x 4
Ø15 x 11.5 mm

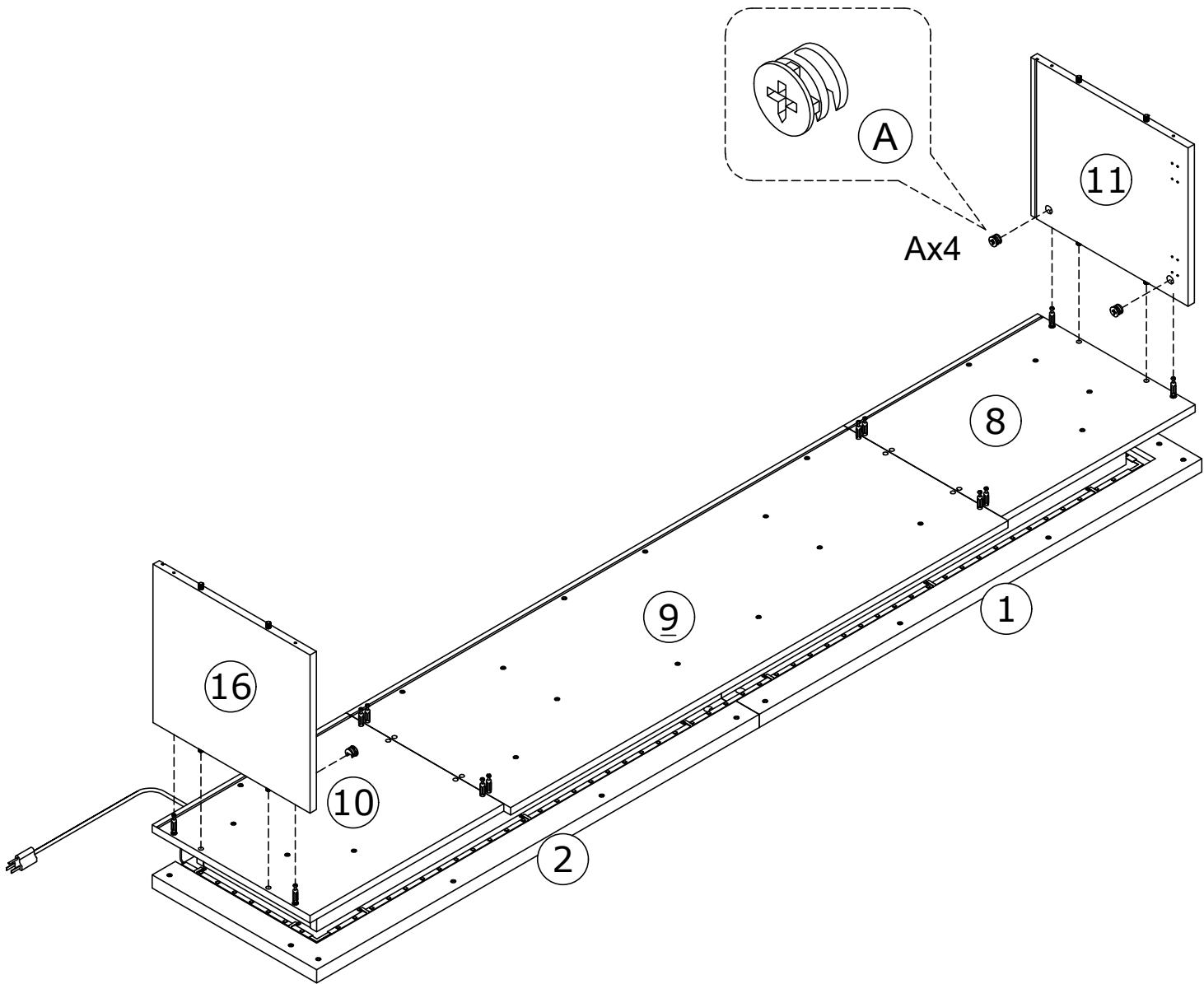
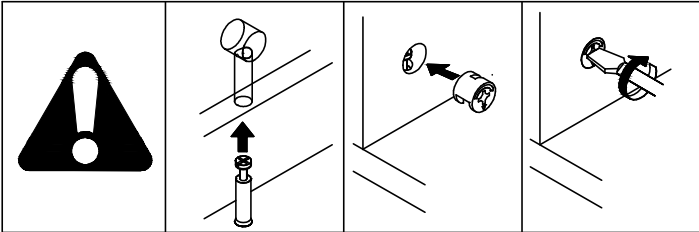
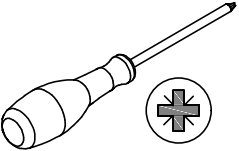

12



A x 6

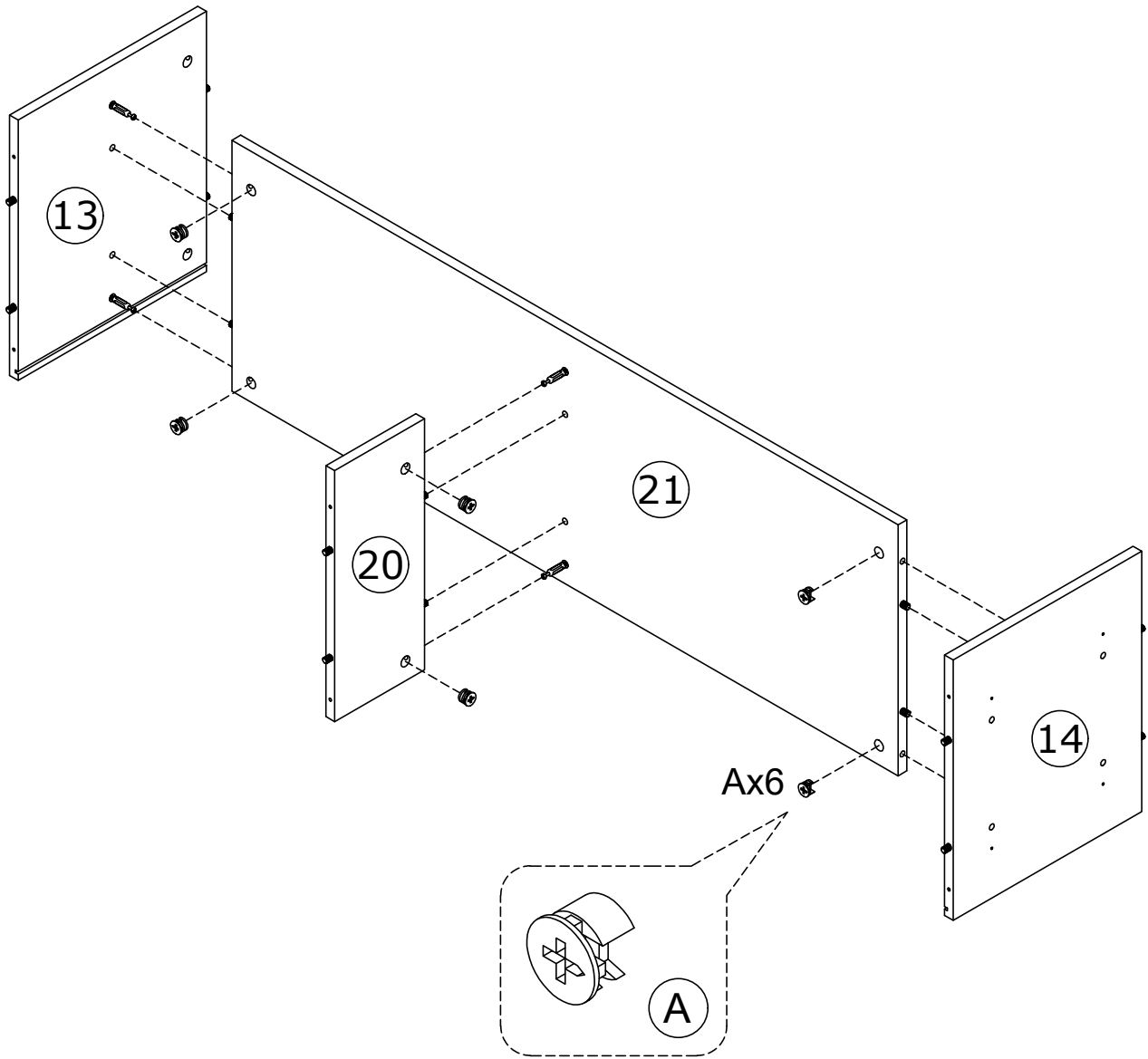
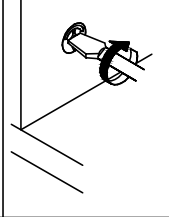
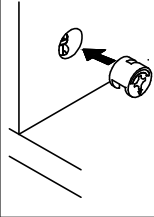
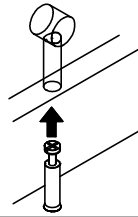
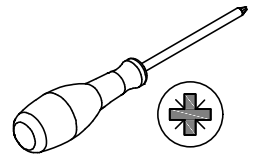

Ø15 x 11.5 mm

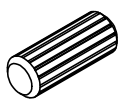
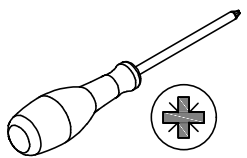

13

<p>O x 8</p>  <p>∅8 x 20 mm</p>	<p>E x 8</p>  <p>∅4 x 25 mm</p>	 
--	--	---

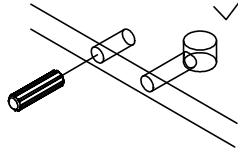
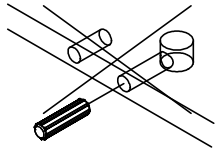
		
---	---	---

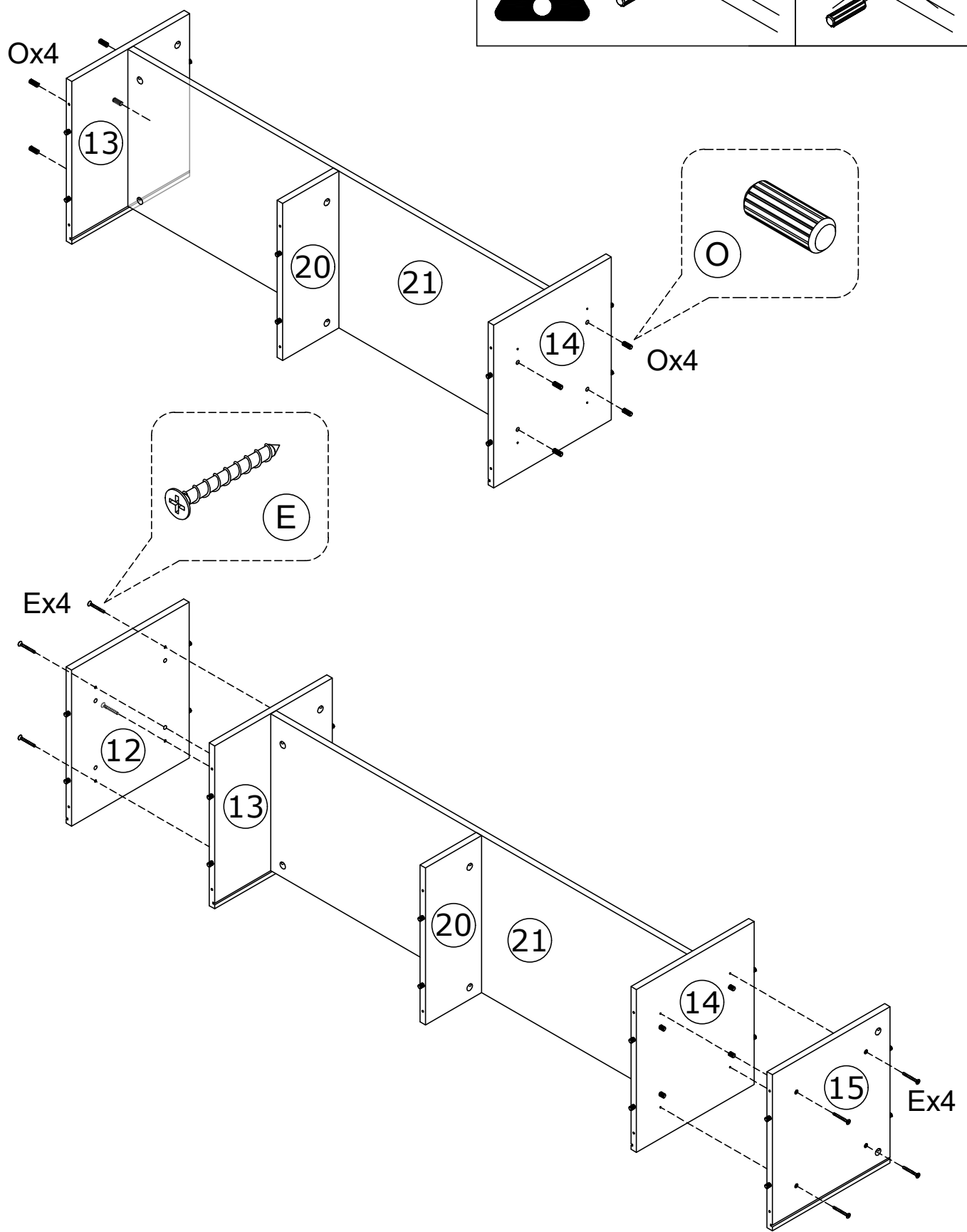

15

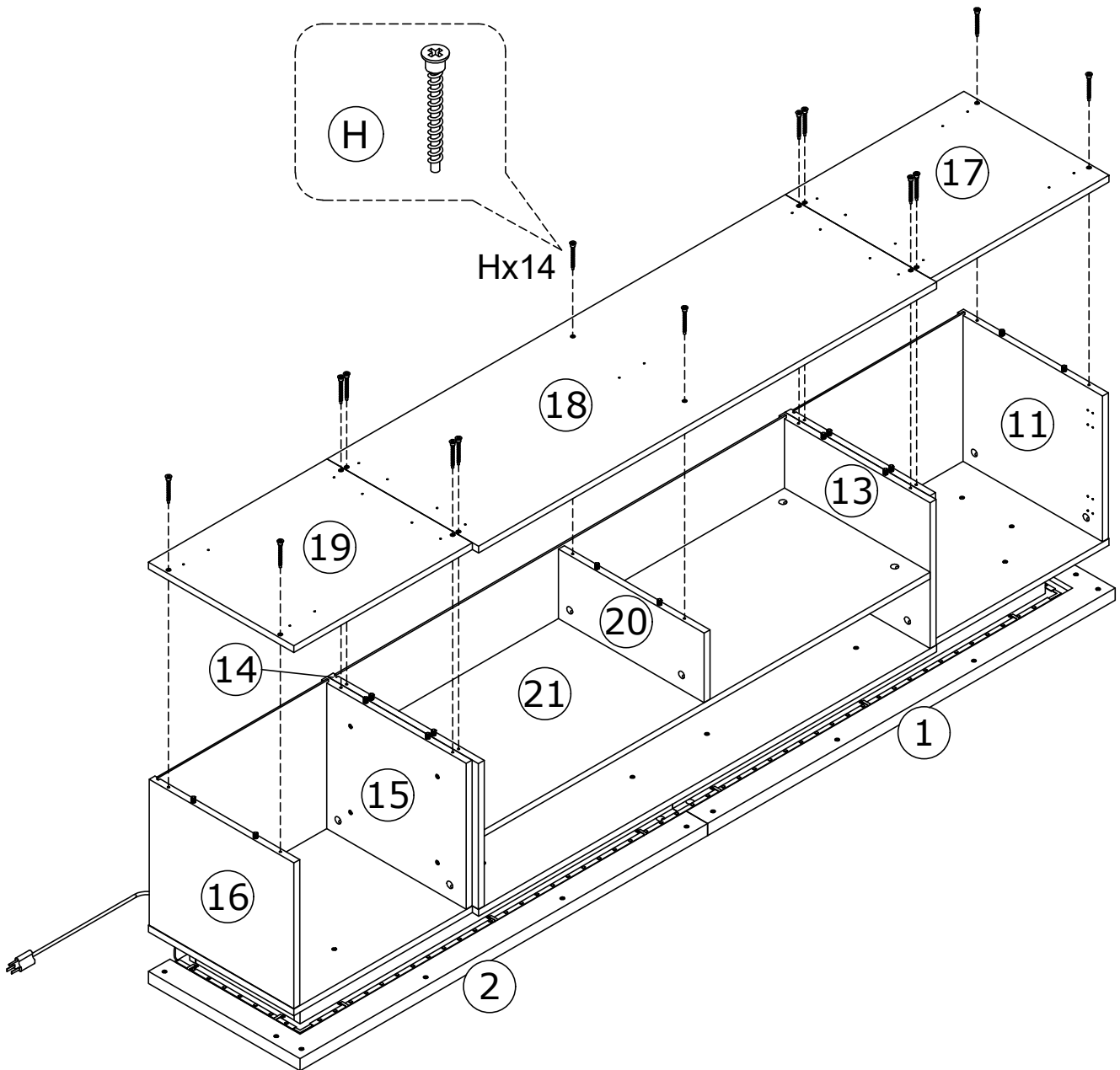
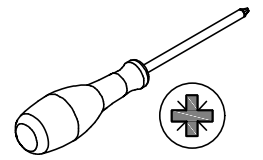
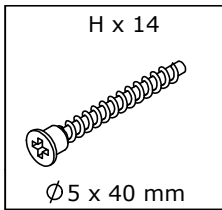

17

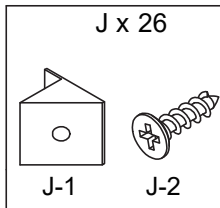

Do not lift the panel to move the product

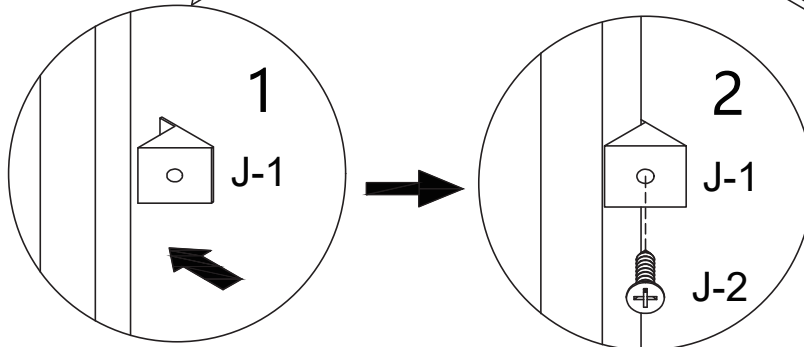
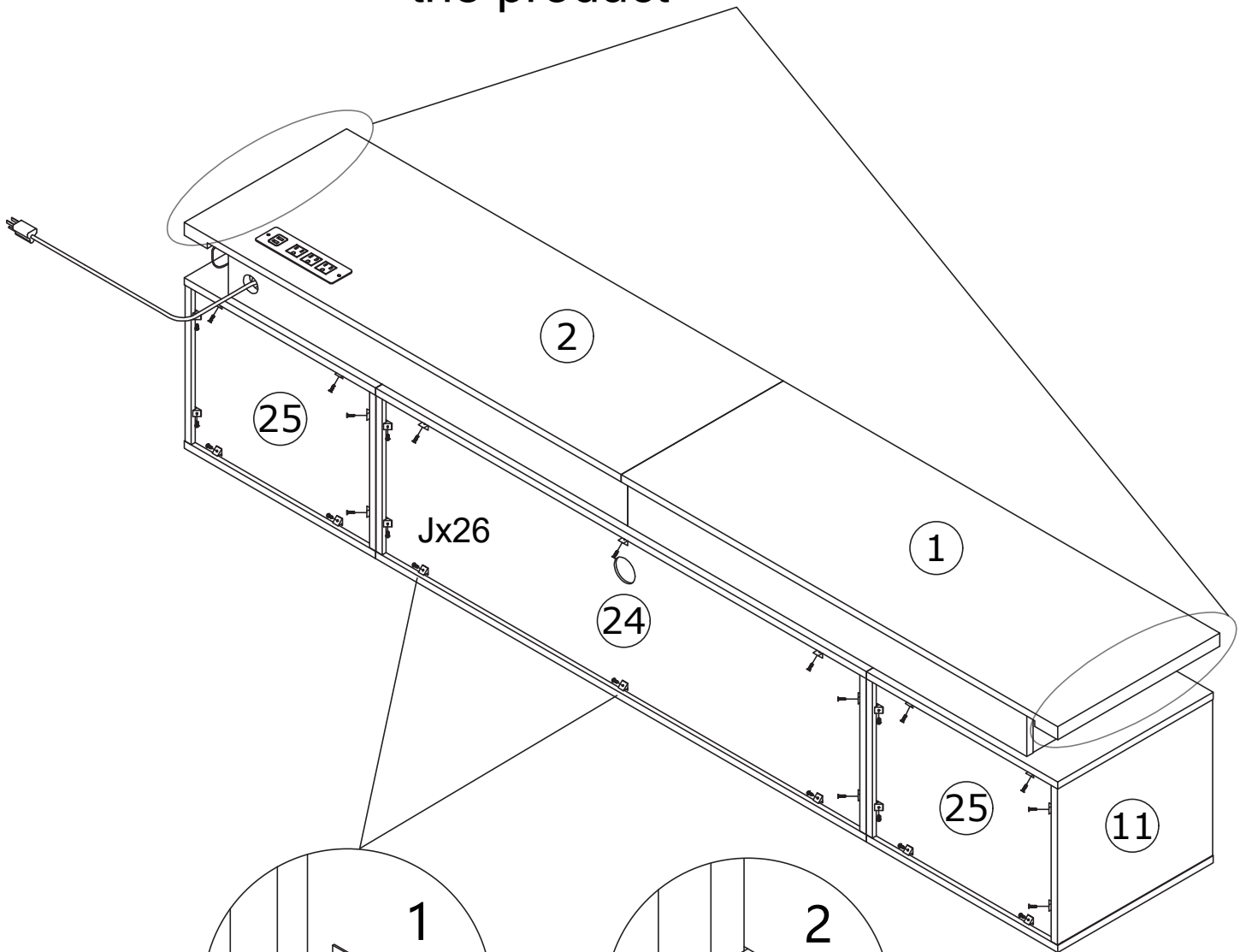

Note: If the hardware J is not installed, it will cause the product shake not firm. Be sure to install back plate buckles as required

18

<p>P x 14</p> 	
---	--

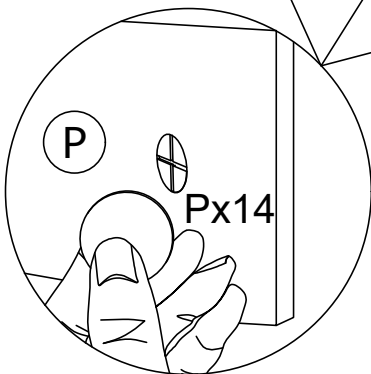
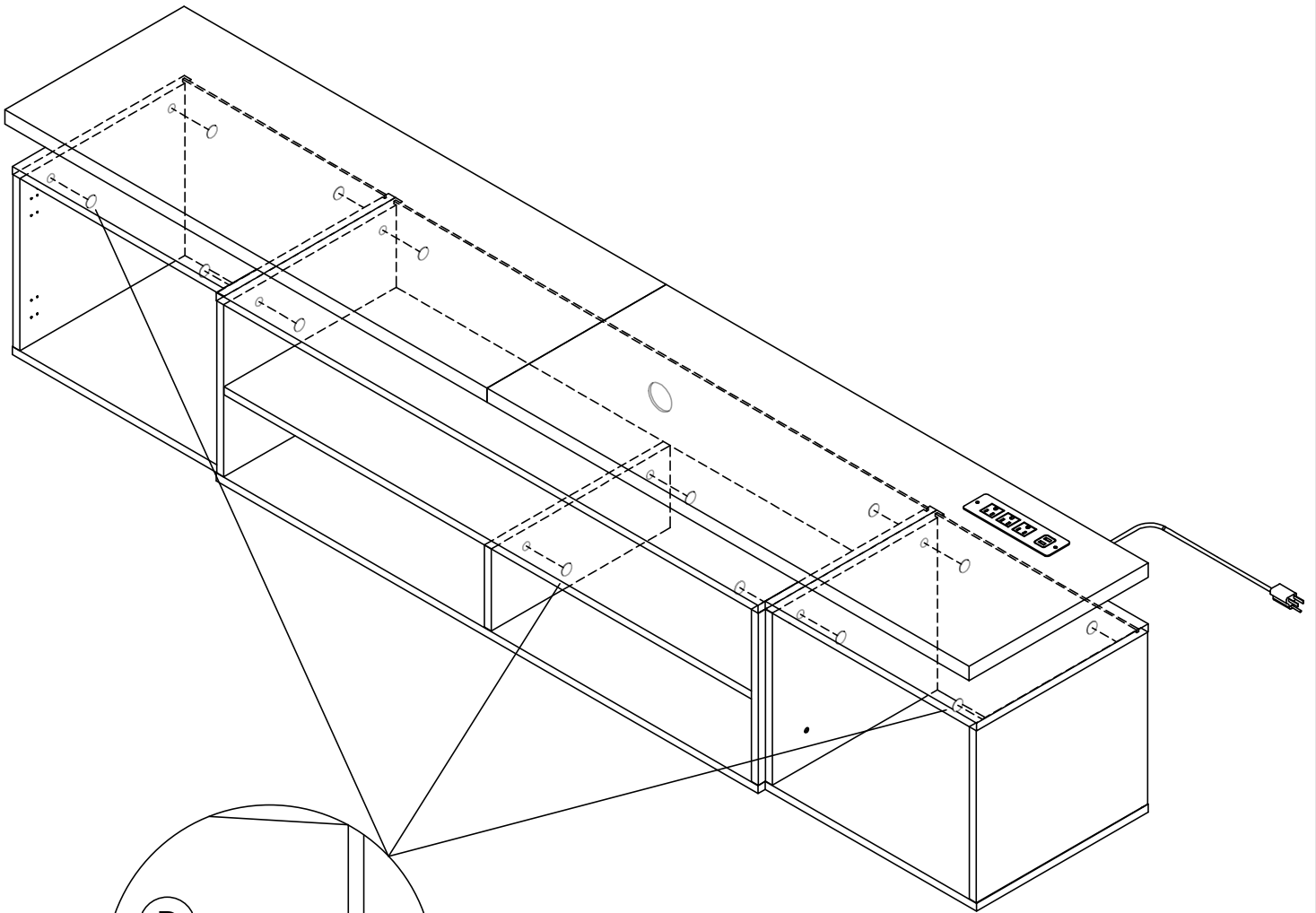

19

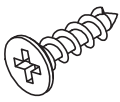
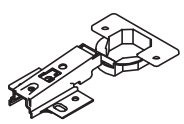
<p>D x 24</p>  <p>Ø3.5 x 14 mm</p>	<p>G x 4</p> 	
---	--	--

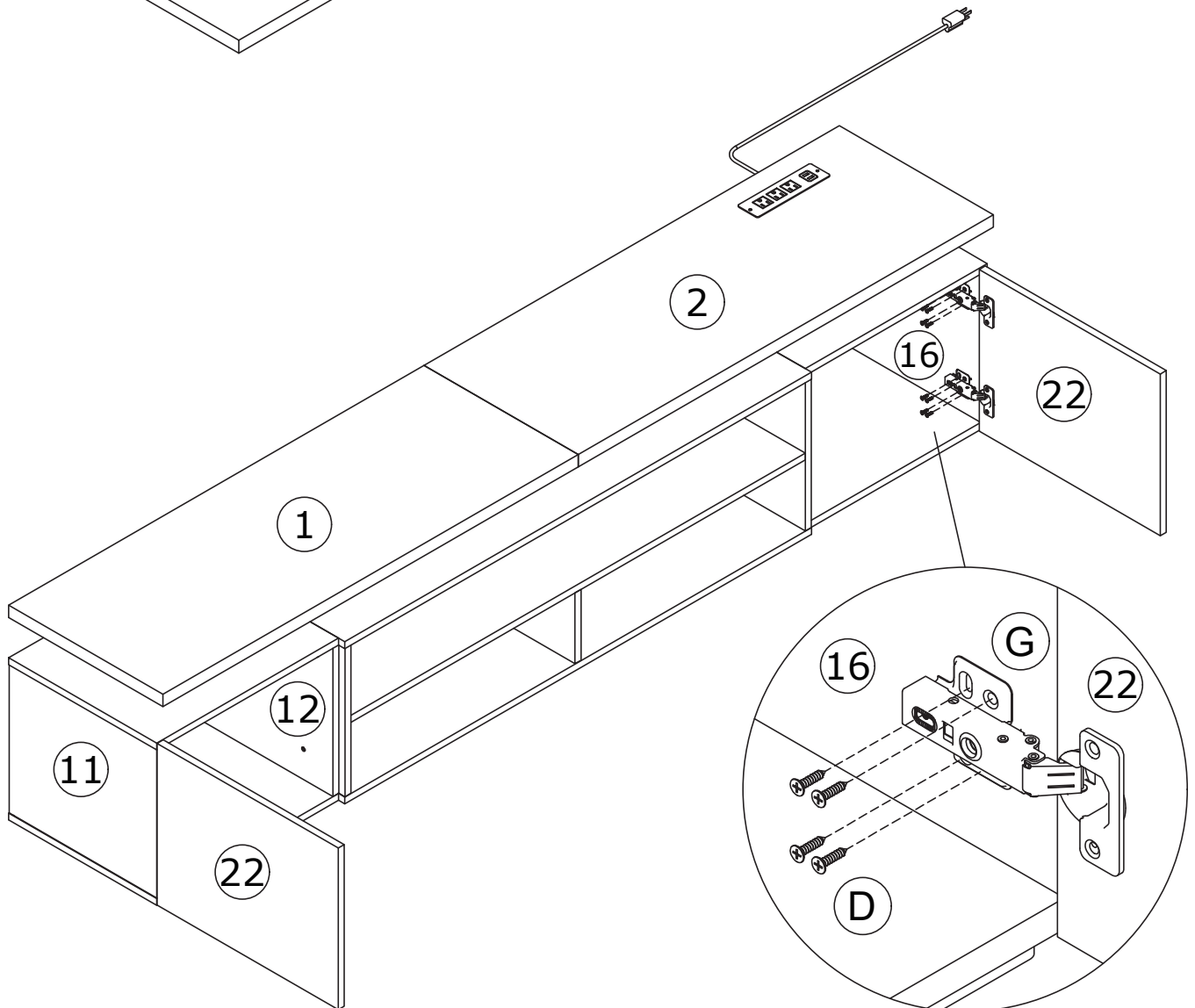
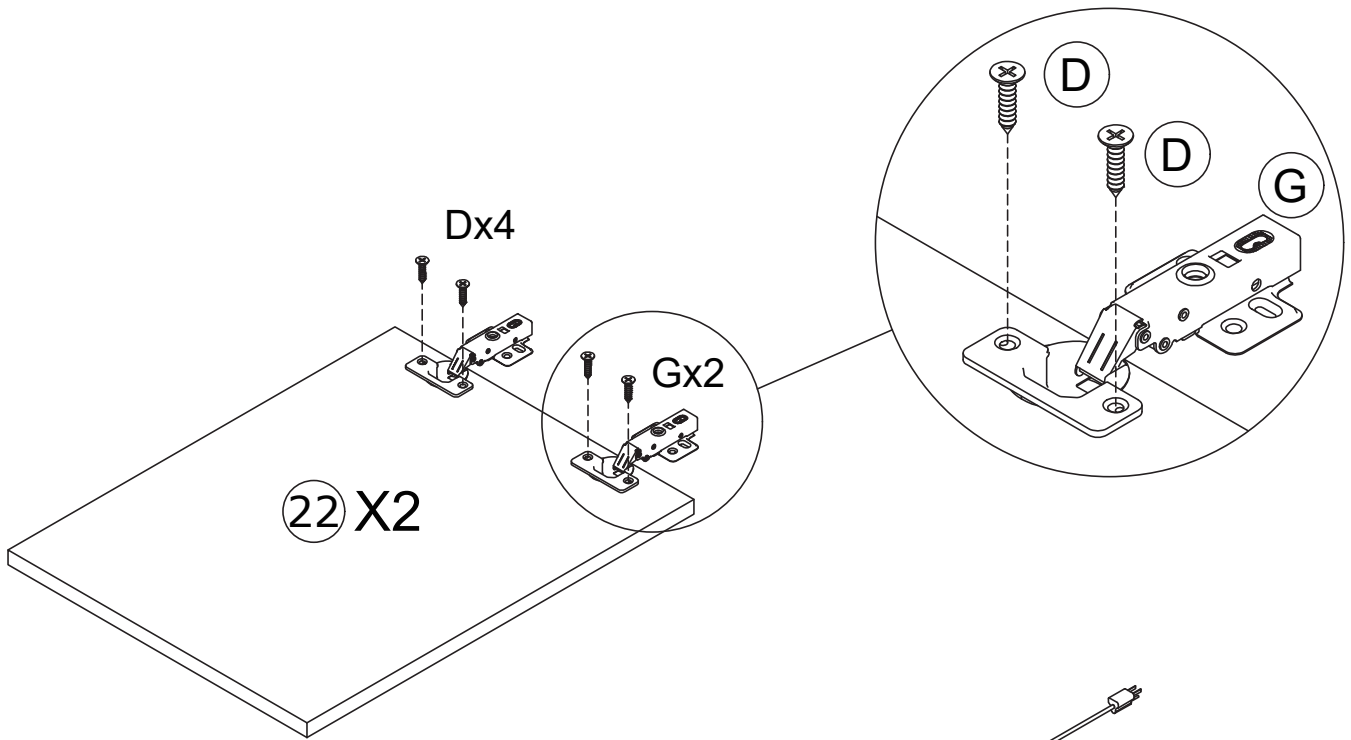

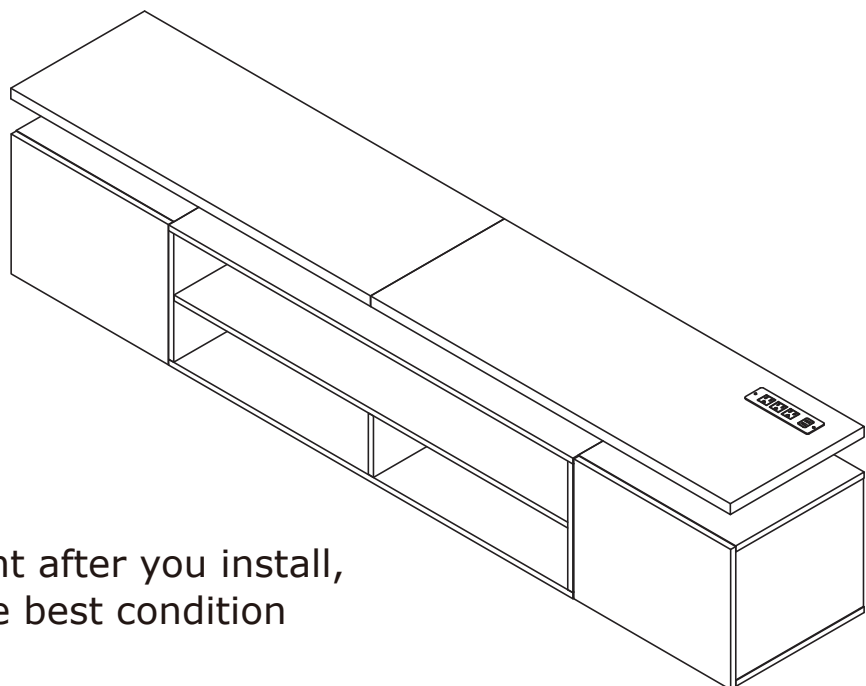

- If there is misalignment after you install, adjust the screw to the best condition

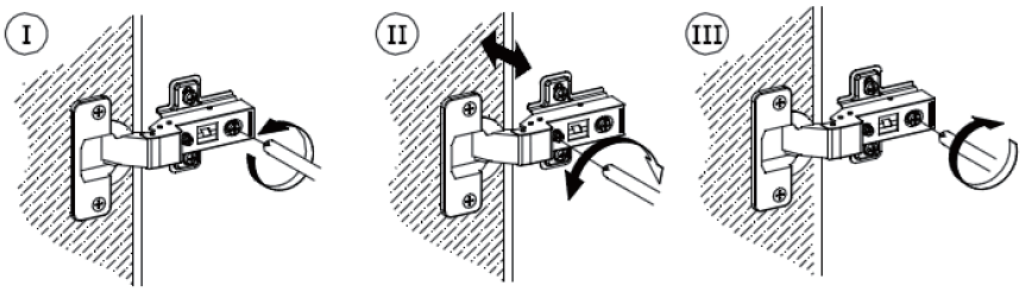
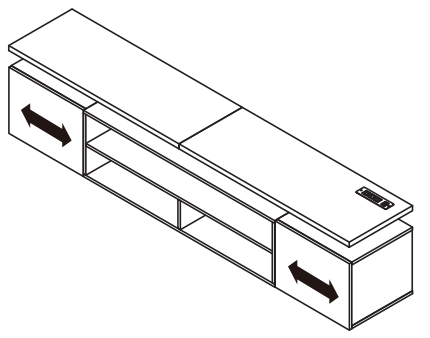
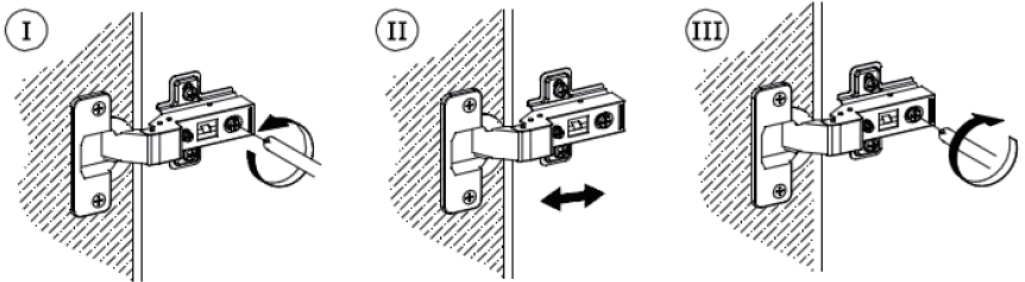
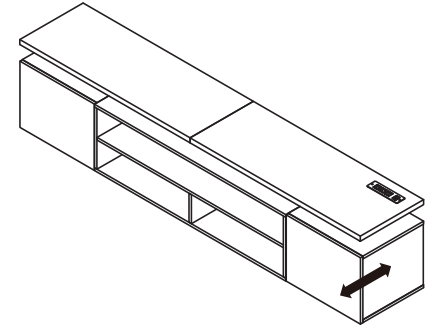
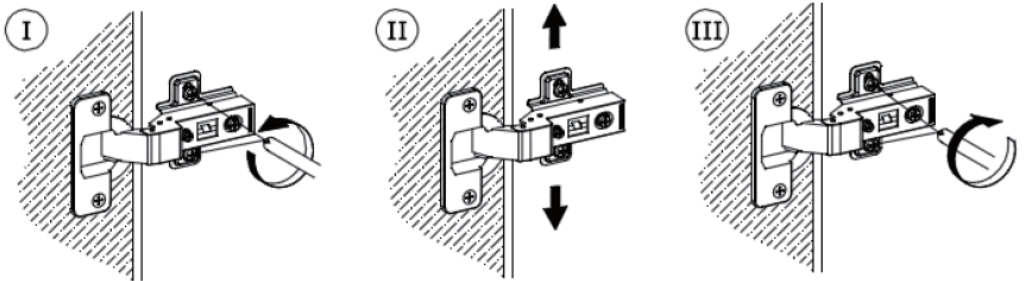
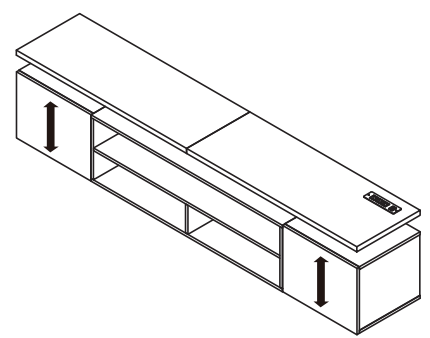

-LED lamp with effective remote control distance of 5 meters

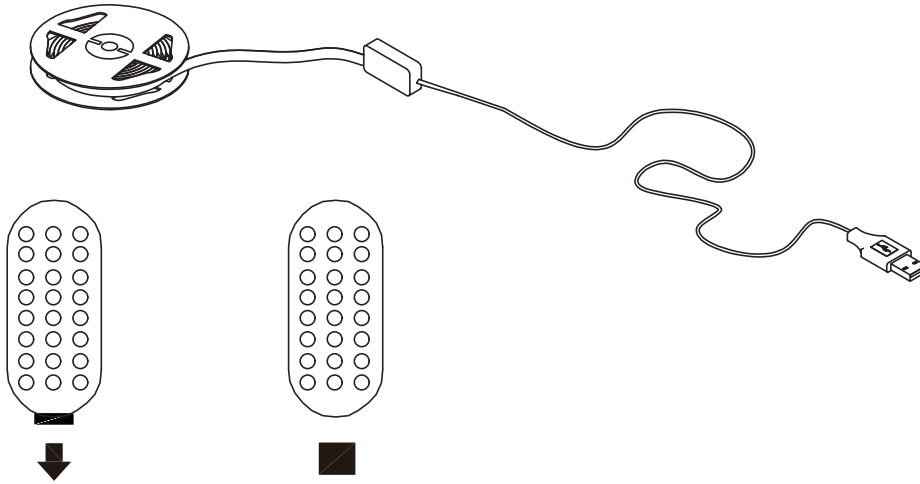

1. Take out the remote control gasket

Remote control mode

	<p>In any state press these two keys to turn on/off the light strip.</p>
	<p>When light is on, press these two keys to reduce-or increase+brightness there are 10 brightness levels for adjustment.</p>
	<p>Press relevant keys to select particular colors</p>
	<p>Press this key to switch static colors There are 16 kinds for chosen.</p>

APP PROGRAM USAGE



- Scan two-dimensional code download APP
- ① Connect LED color strip and controller, power on controller
 - ② Scan two-dimensional code download APP:
 - ③ Start APP, search and connect controller
 - ④ Enjoy the Bluetooth wireless control experience

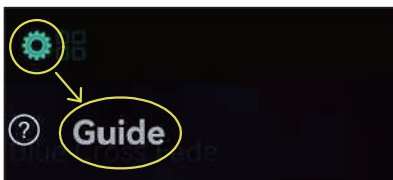

Notes:
detailed operating instructions, enter the menu "Guide":

- Product Paramters:
- Bluetooth: BLEV4.2
 - Input Voltage:4.5~26V
 - Working Temp:-25~75°C
 - Size:43*22*11mm
 - Weight:30g
 - Max Power:144W(24V)

LED mobile phone Bluetooth controllerProduct Features

- LED Bluetooth controller is directly via mobilephone control remote distance can reach 20m without the need to set up, easy to connect open the software within 5 seconds you can automatically connect the controller
 - Flow the rhythm of the music changes
 - Group control
 - Brightness, speed addition and subtraction
 - Maximum can be 10 meters RGB(W) strip
 - The software shows that the text is based onthe language of the mobile phone set up automatic transformation of Chinese and English
- Animation Effect:
- Colorful gradient
 - All kinds of monochrome, double color gradient
 - All kinds of monochrome, double color,colorfull flashing
 - Colorful jump
 - Follow the thymh of the music chagnes