

WF314847 AAF/AAA/AAE
WF314848 AAF/AAA/AAE

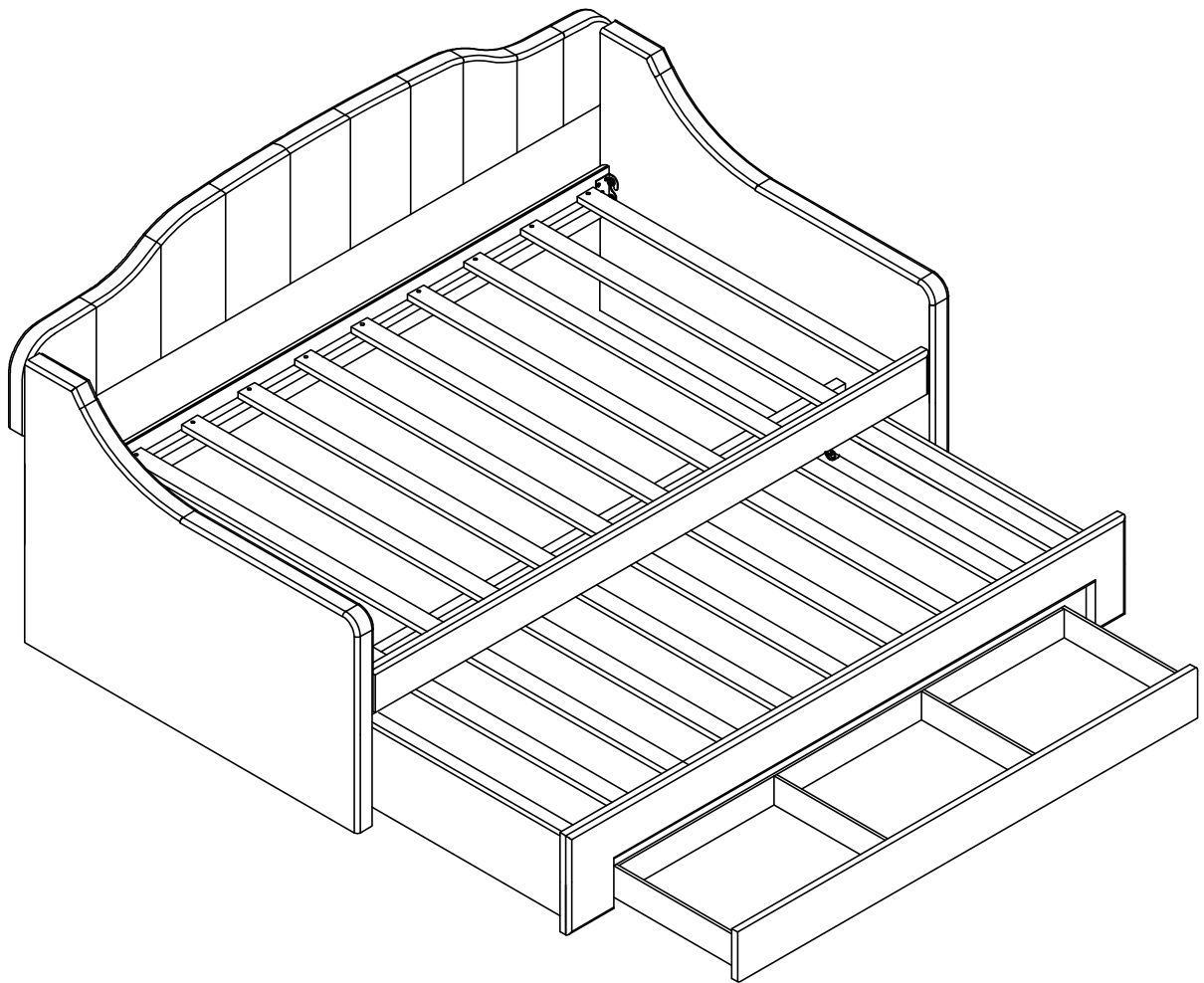

ASSEMBLY INSTRUCTIONS

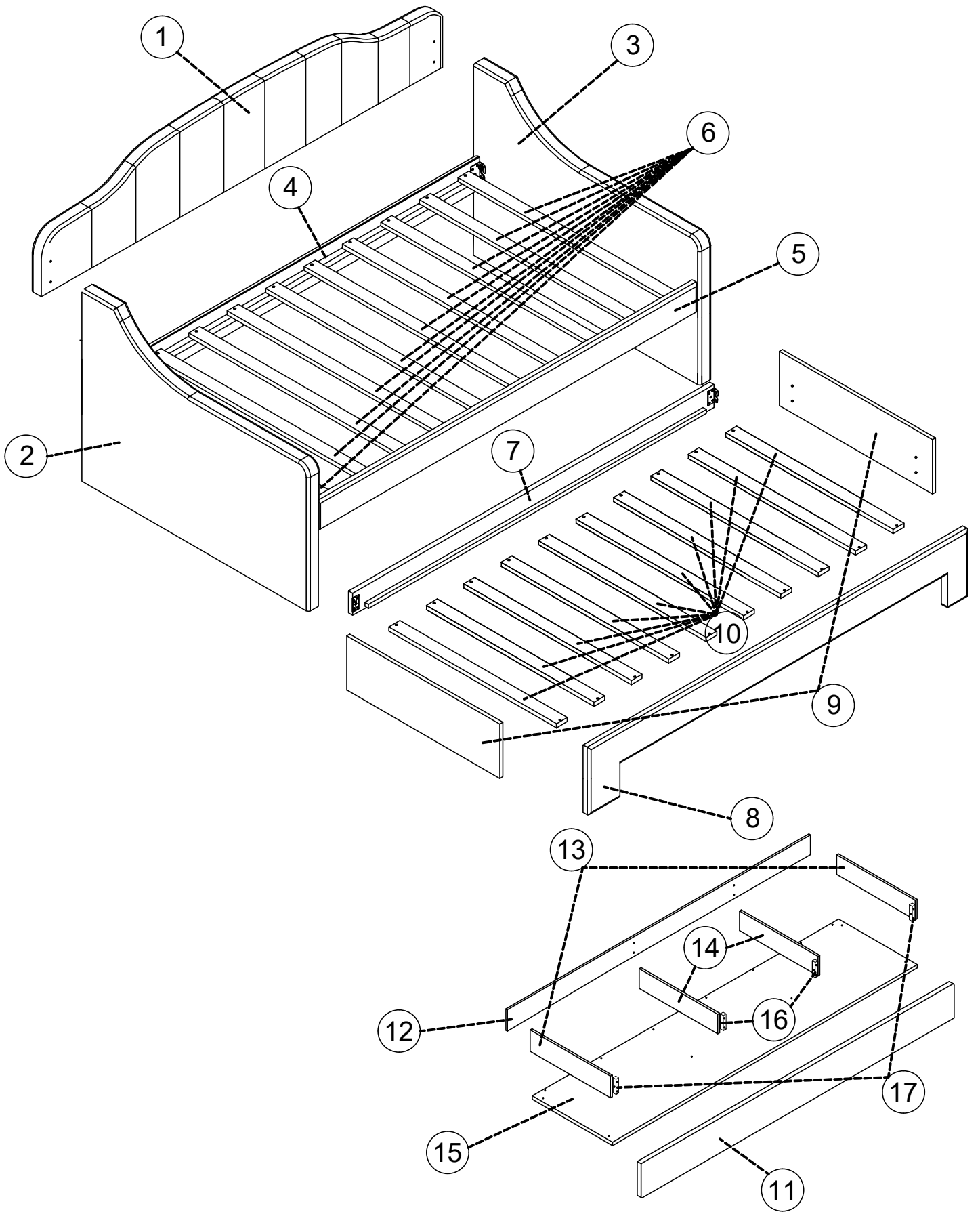

PATSI

Check that you've received all hardware listed below.

BOX 1/2
WF314847 AAF/AAA/AAE

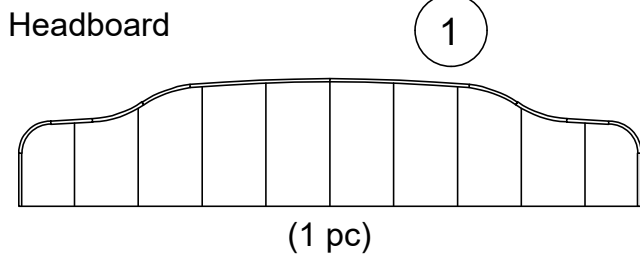
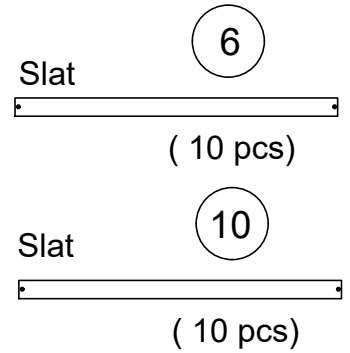
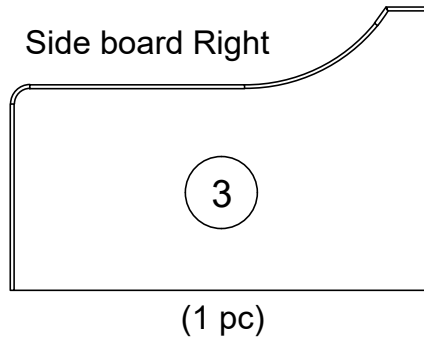
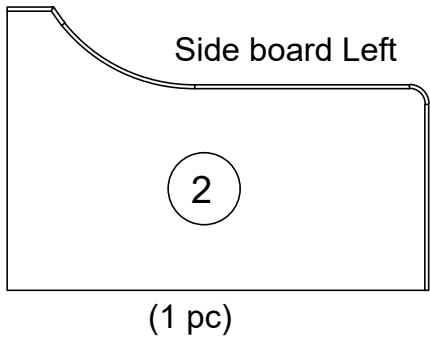



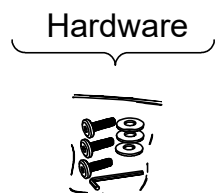
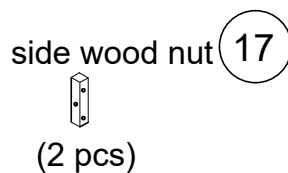
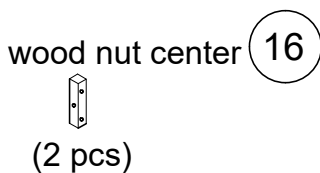
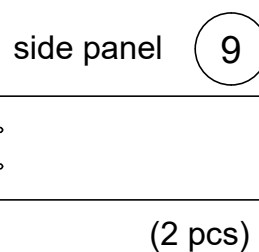
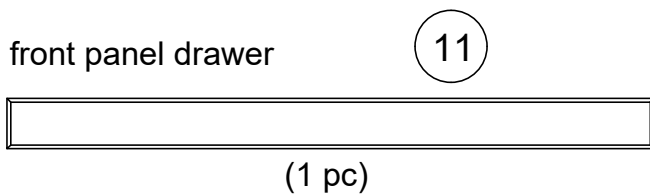
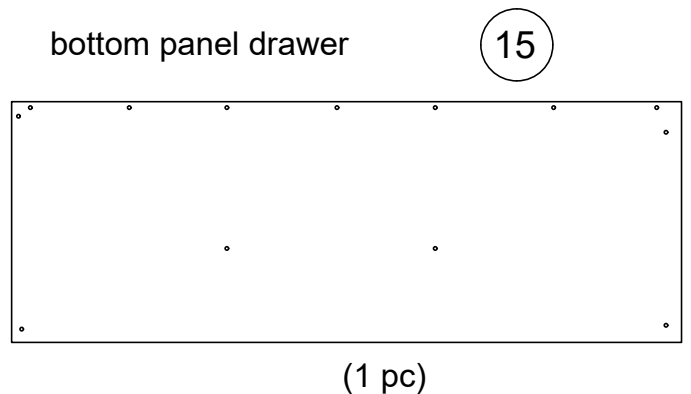
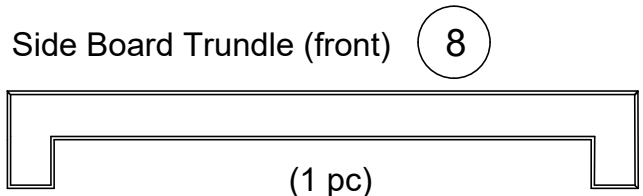
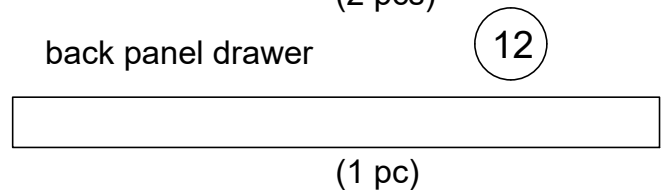
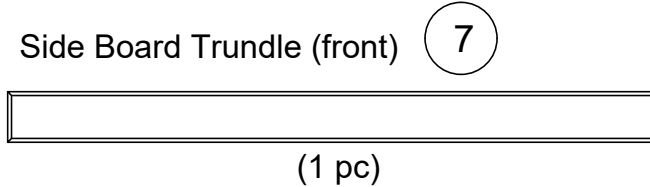
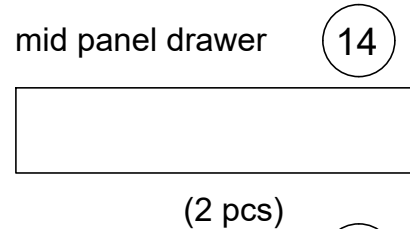
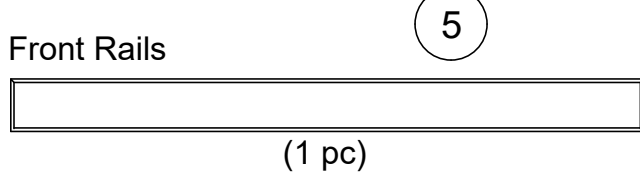
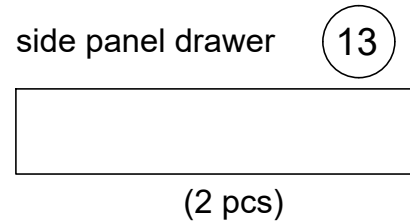
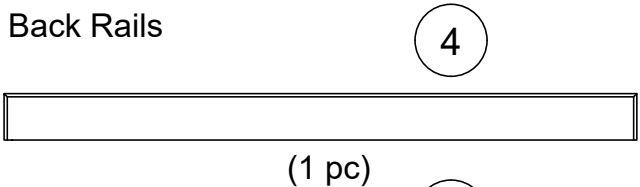









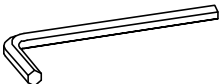

BOX 2/2
WF314848 AAF/AAA/AAE





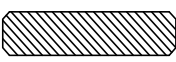

HARDWARE

Check that you've received all hardware listed below.

Hardware List



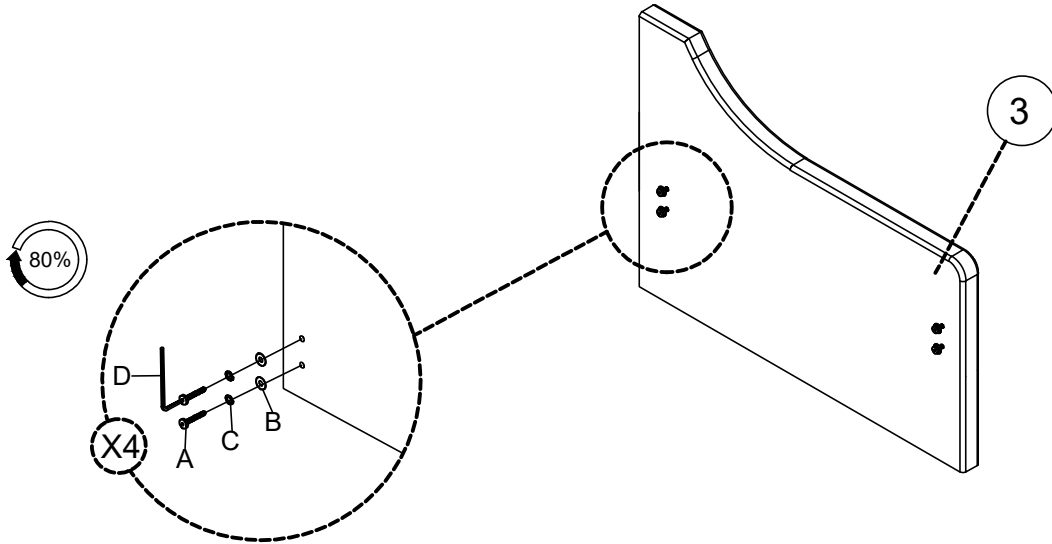

No.	OUTLOOK	DESC	QTY
(A)		Bolts 5/16"x30 mm	8
(B)		Plain washer Ø19x1.5 mm	20
(C)		Spring washer Ø13x1 mm	20
(D)		Allen key 80x30x4 mm	1
(E)		Bolts 5/16"x20 mm	8
(F)		Bolts 5/16"x45 mm	4
(G)		Bolts 1/4"x30 mm	4
(H)		Plain washer Ø16x1.5 mm	4
(I)		Spring washer Ø11x1 mm	4
(K)		Screws Ø4x30 mm	40
(L)		Screws Ø4x20 mm	33
(M)		Screws Ø4x15 mm	16
(N)		Screws Ø4x10 mm	8
(O)		Wheel 50x40x25 mm	4
(P)		Wheel 37x35x22 mm	4
(Q)		wooden pegs 6X30 mm	4

STEP 1

A x 4 	B x 4 	C x 4 	D x 1 	
--	--	--	--	--



STEP 2

A x 4 	B x 4 	C x 4 	D x 1 	
--	--	--	--	--

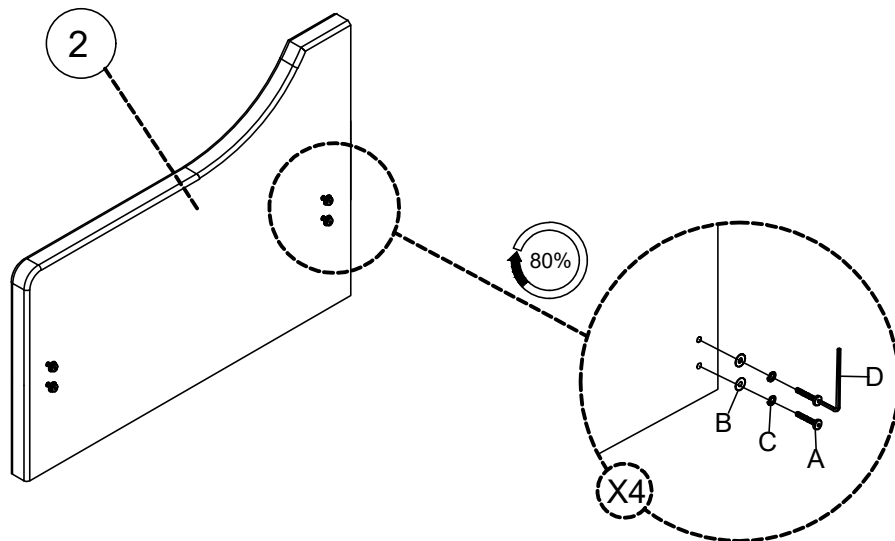

STEP 3

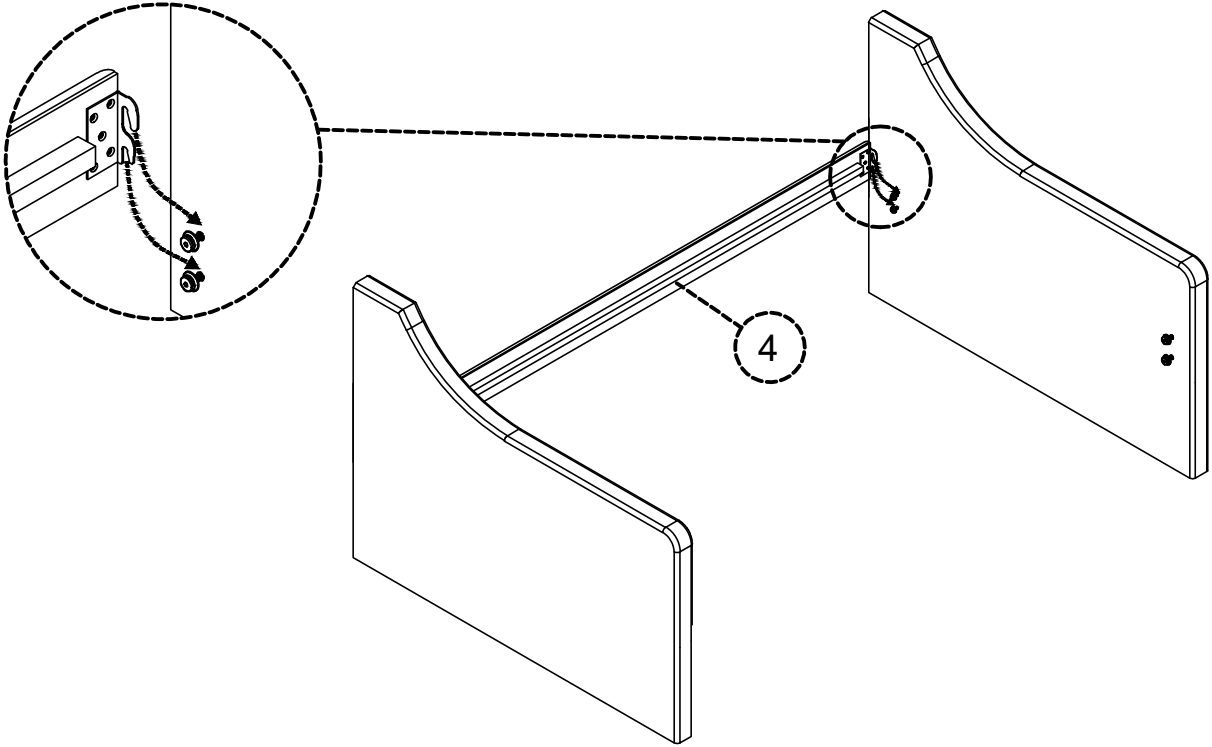
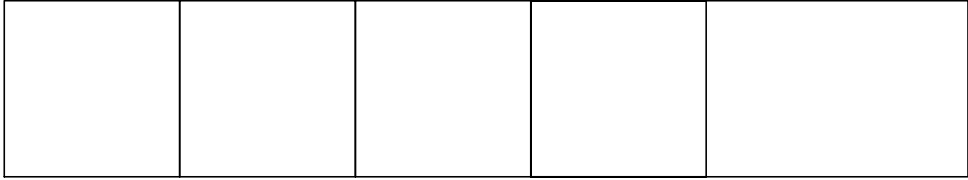

STEP 4

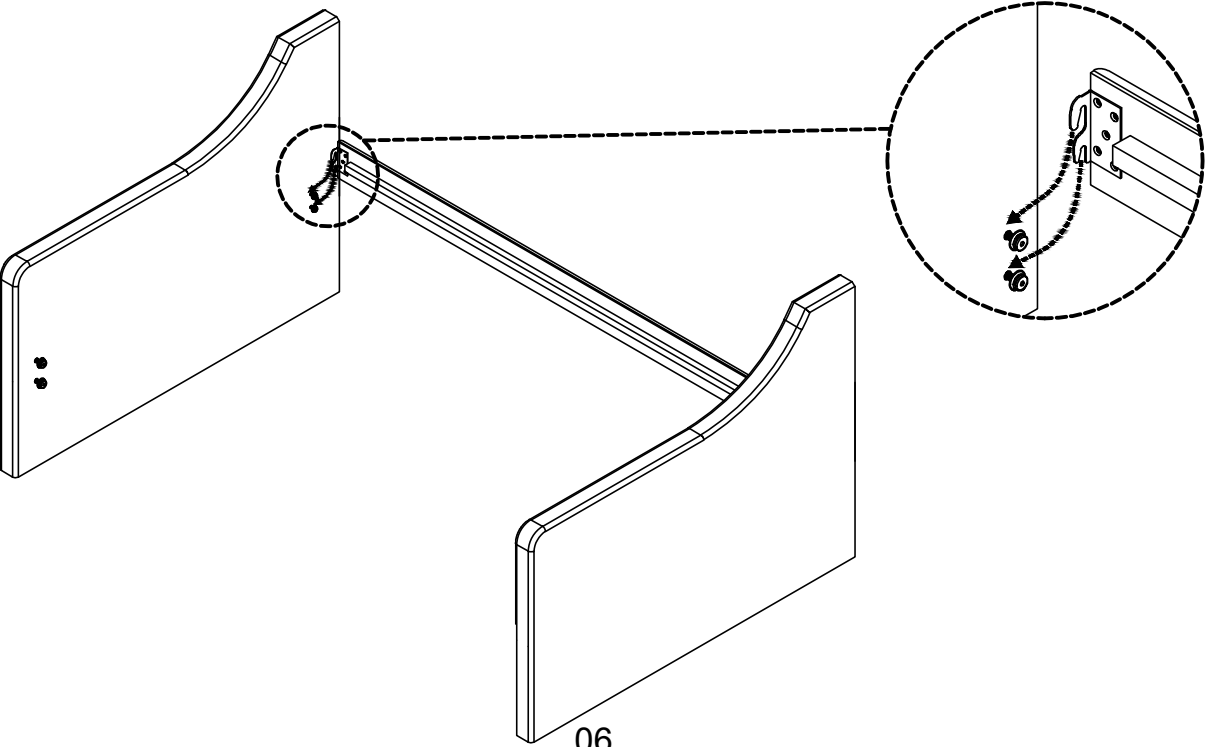
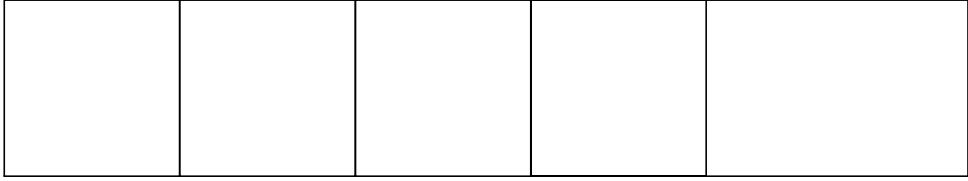



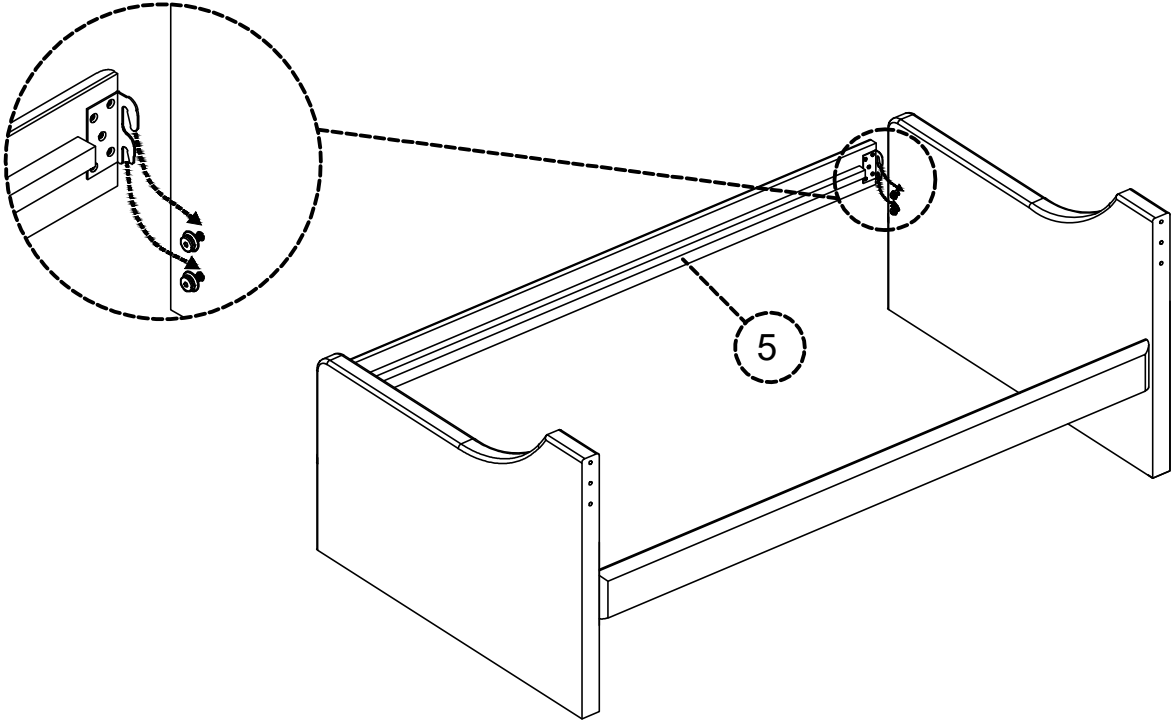
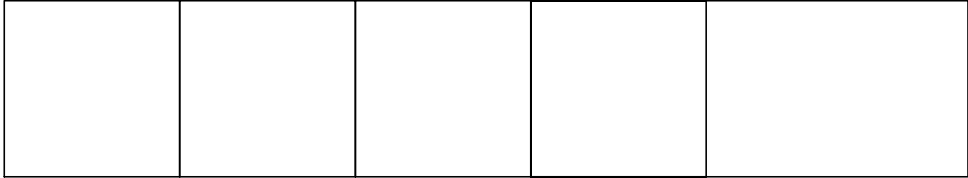

STEP 5

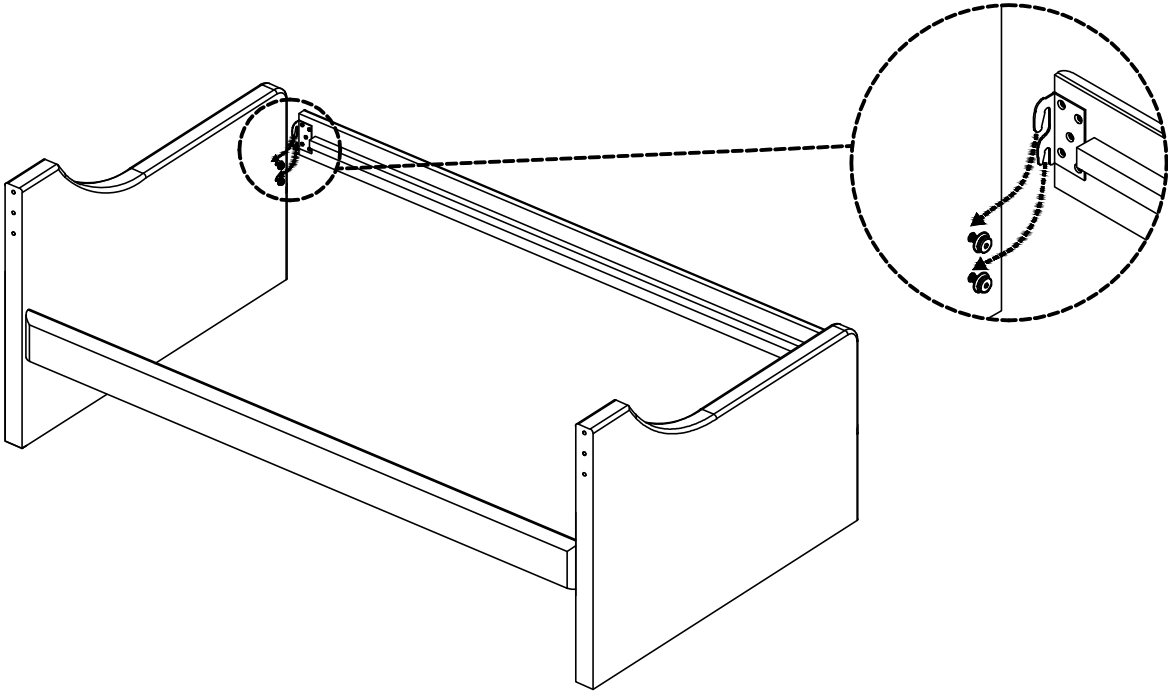
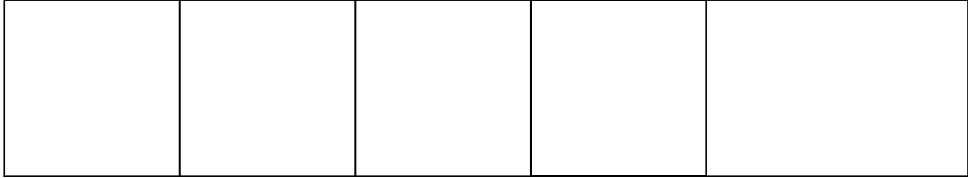

STEP 6



STEP 7

F x 4 	B x 4 	C x 4 	D x 1 	
--	--	--	--	--

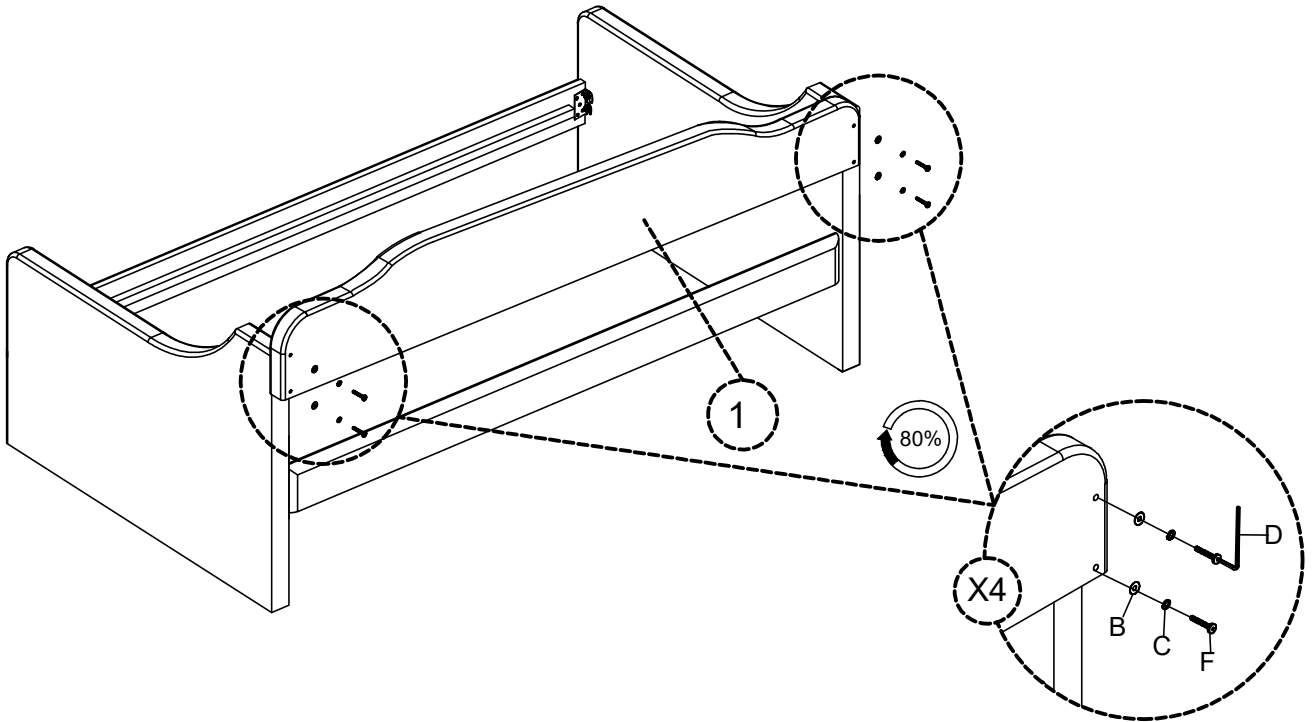

STEP 8

D x 1 				
--	--	--	--	--

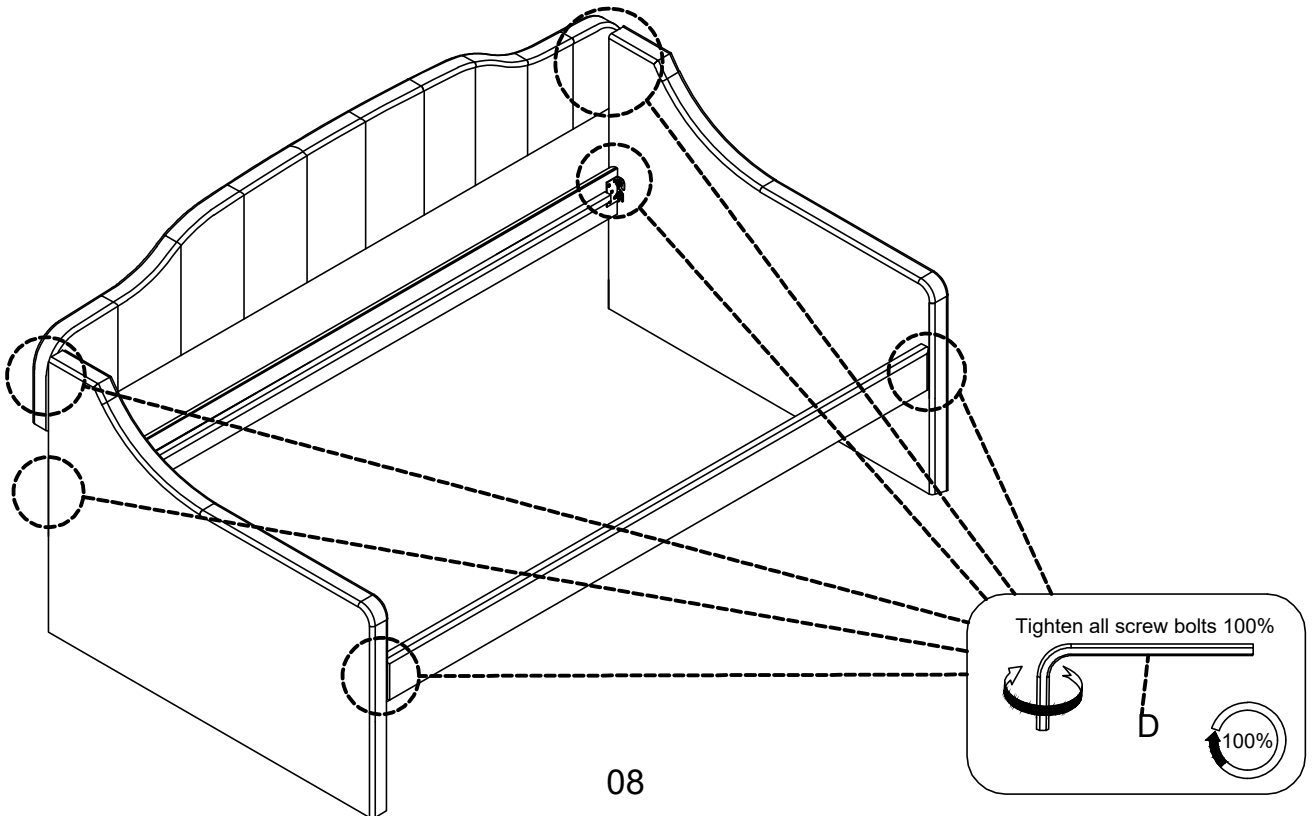



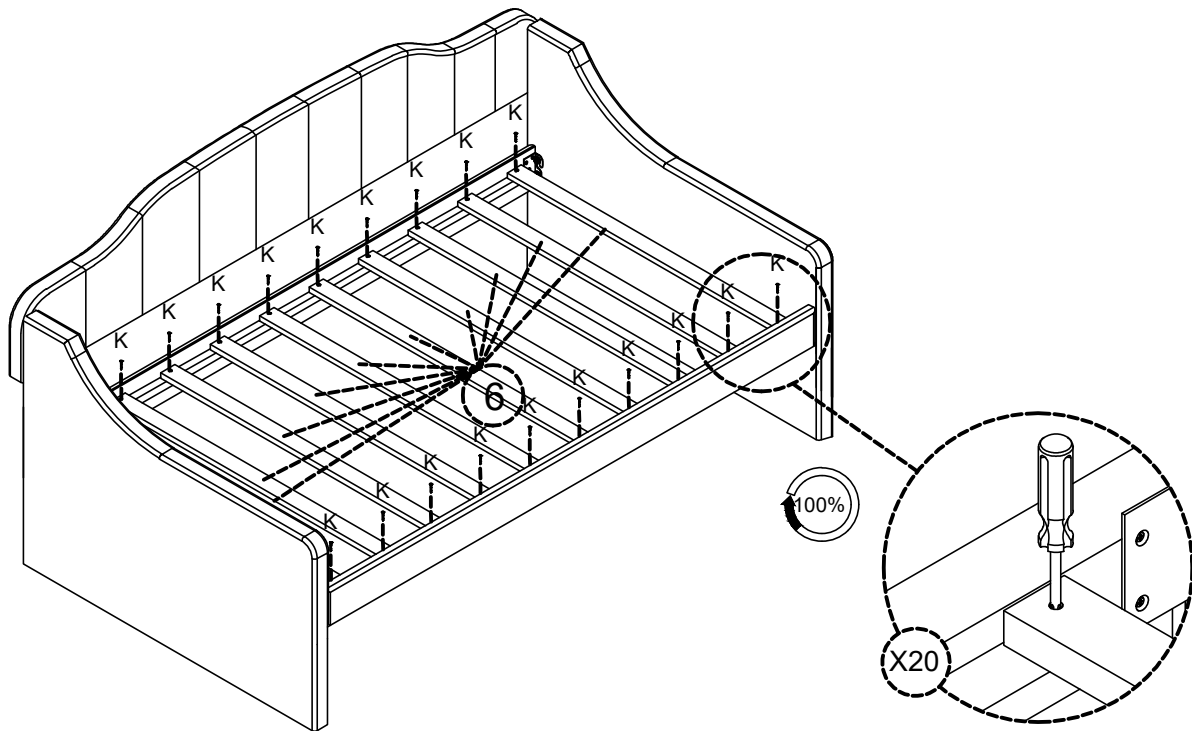
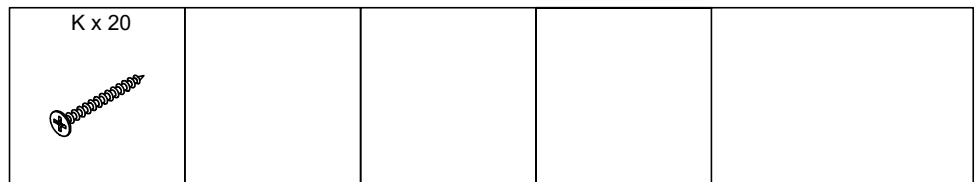

STEP 9

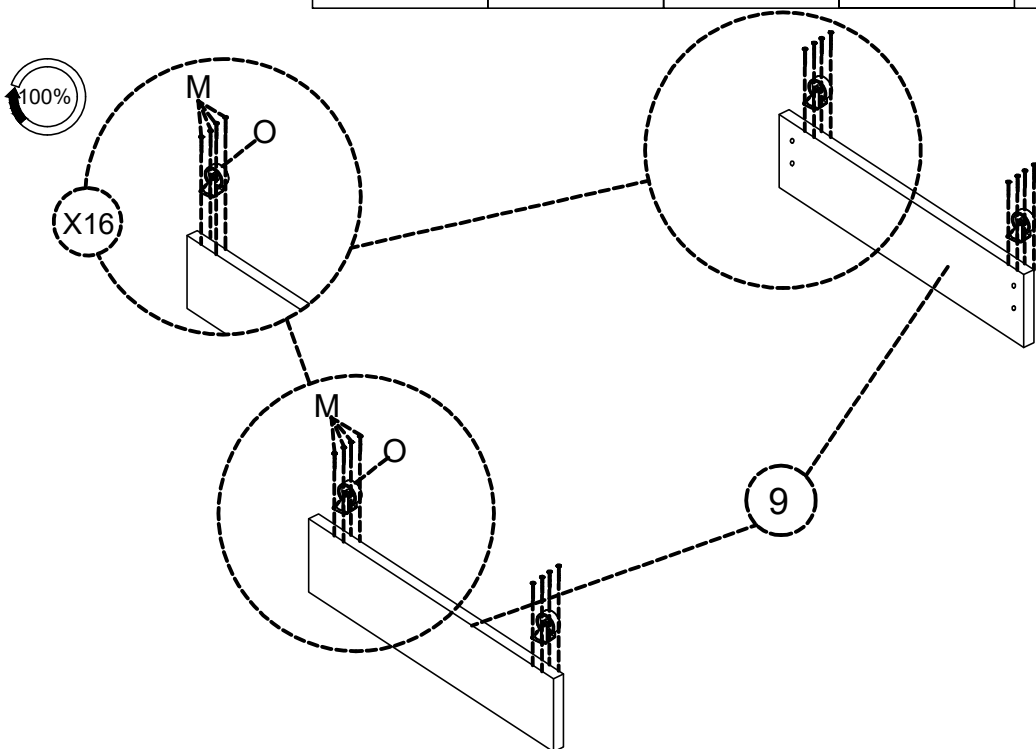
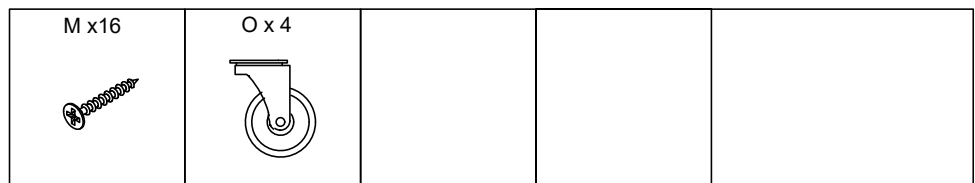

STEP 10



STEP 11

E x 8 	B x 8 	C x 8 	D x 1 	
--	--	--	--	--

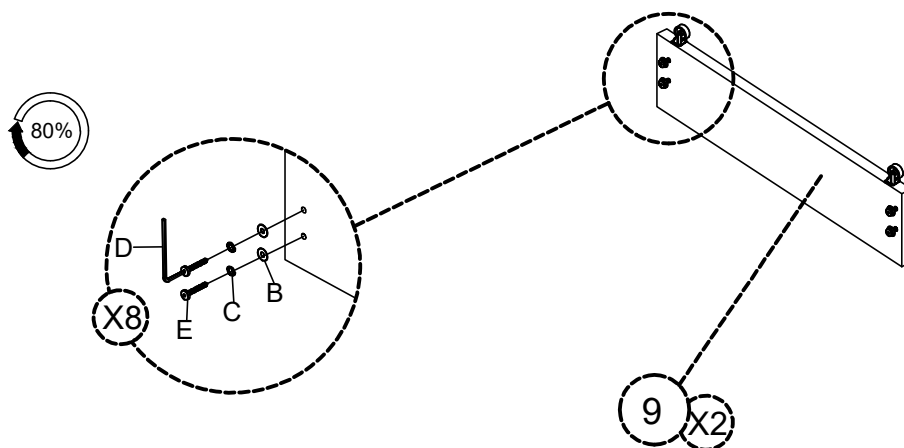

STEP 12

--	--	--	--	--

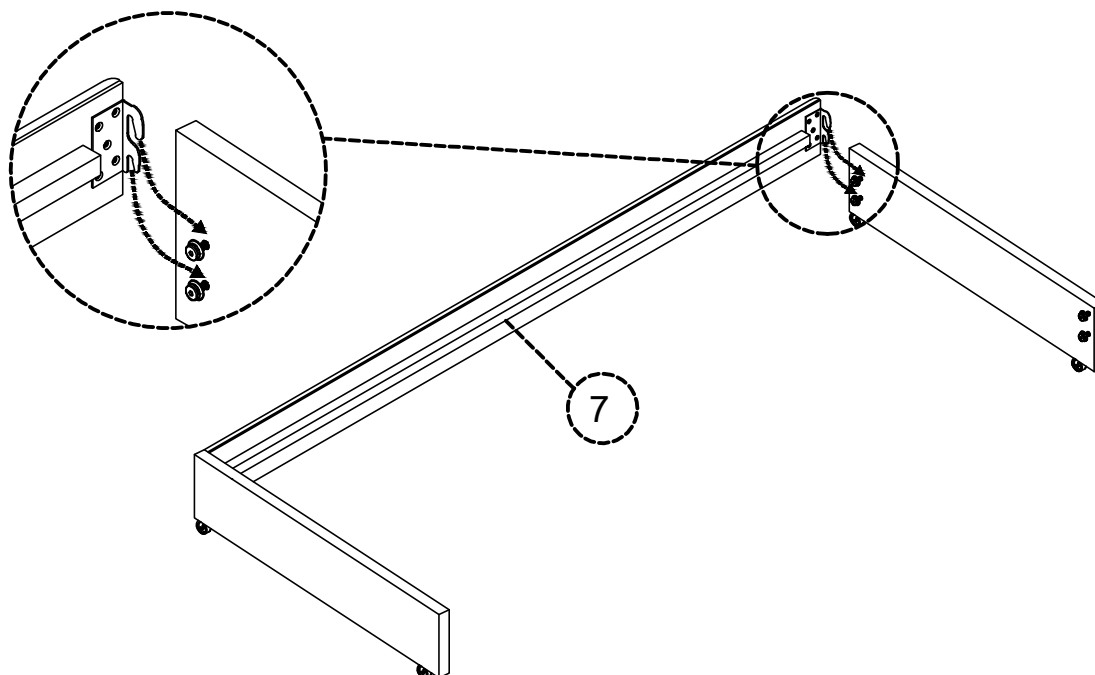

STEP 13

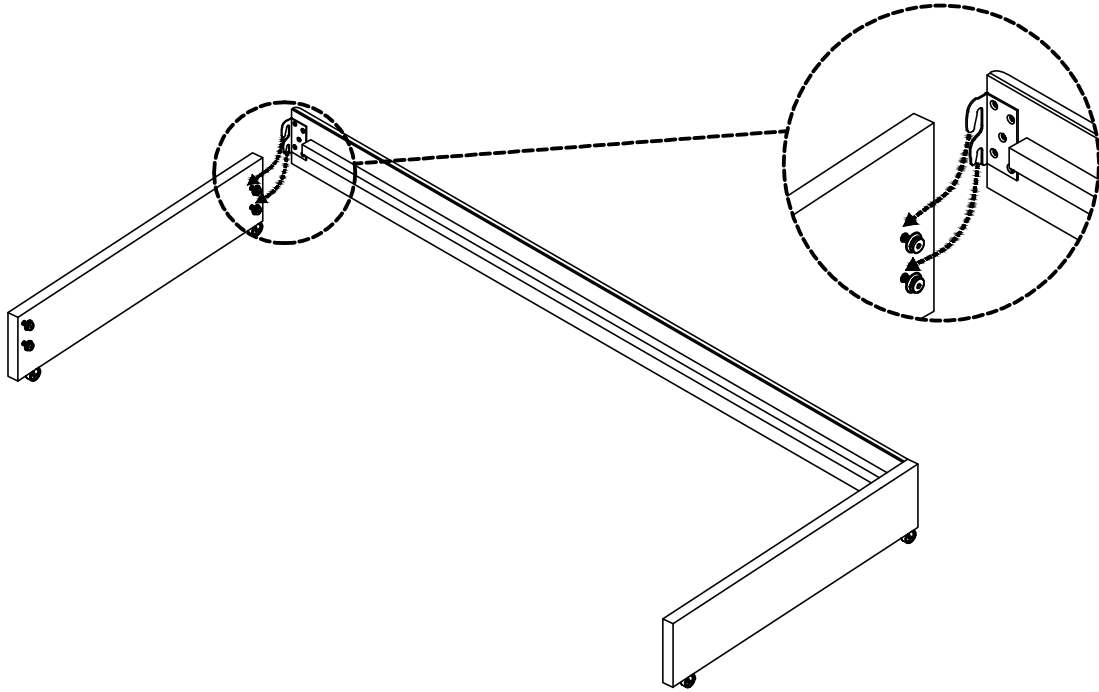
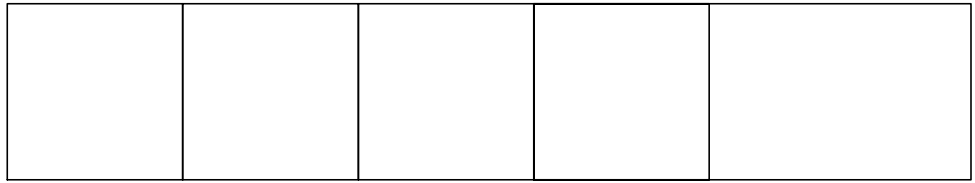

STEP 14

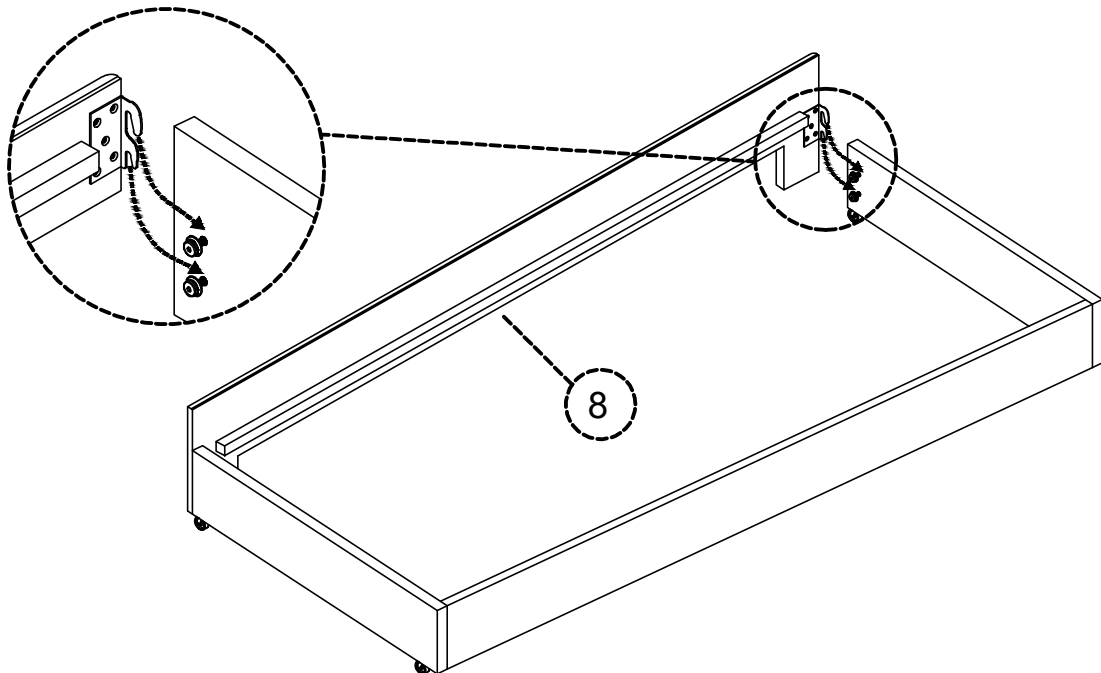
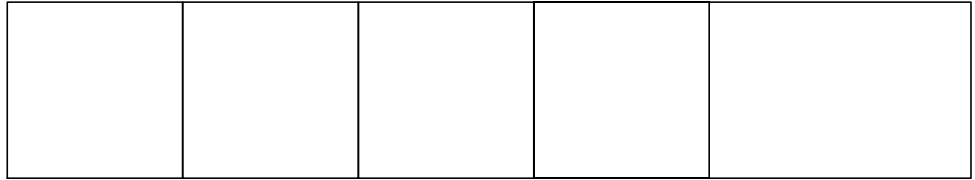

STEP 15

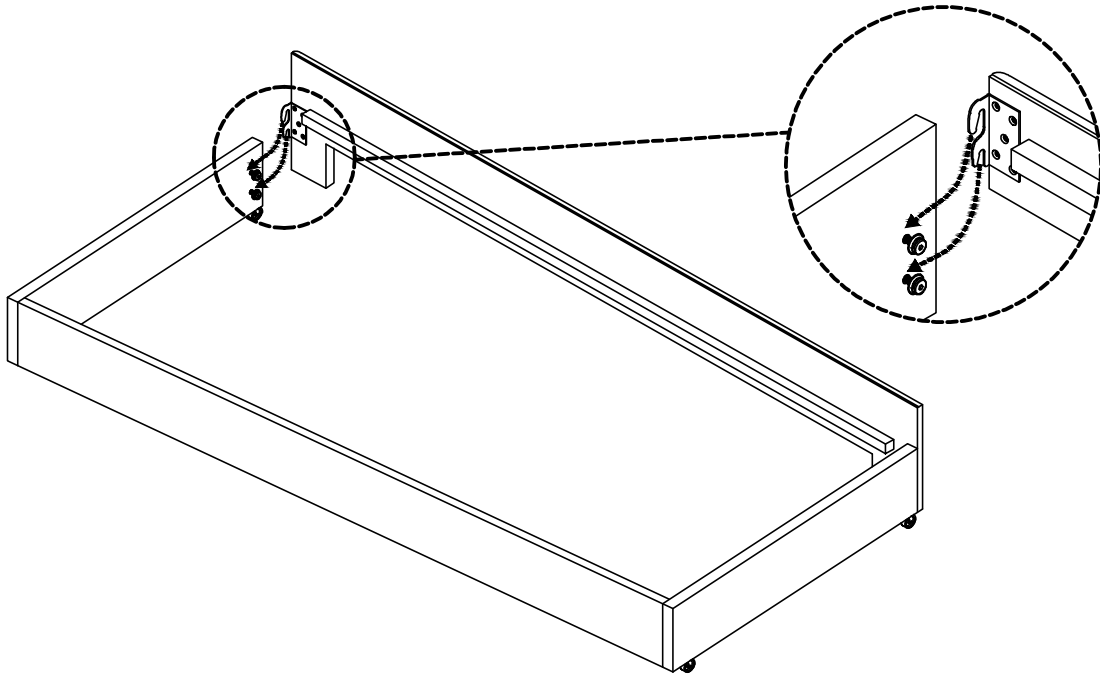
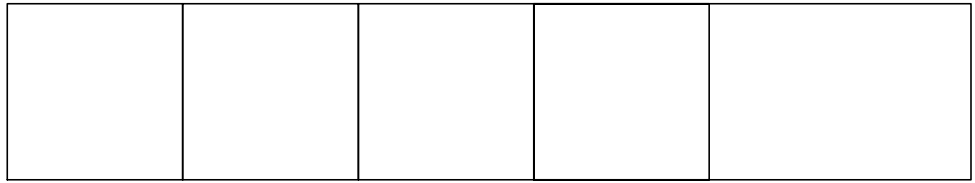

STEP 16

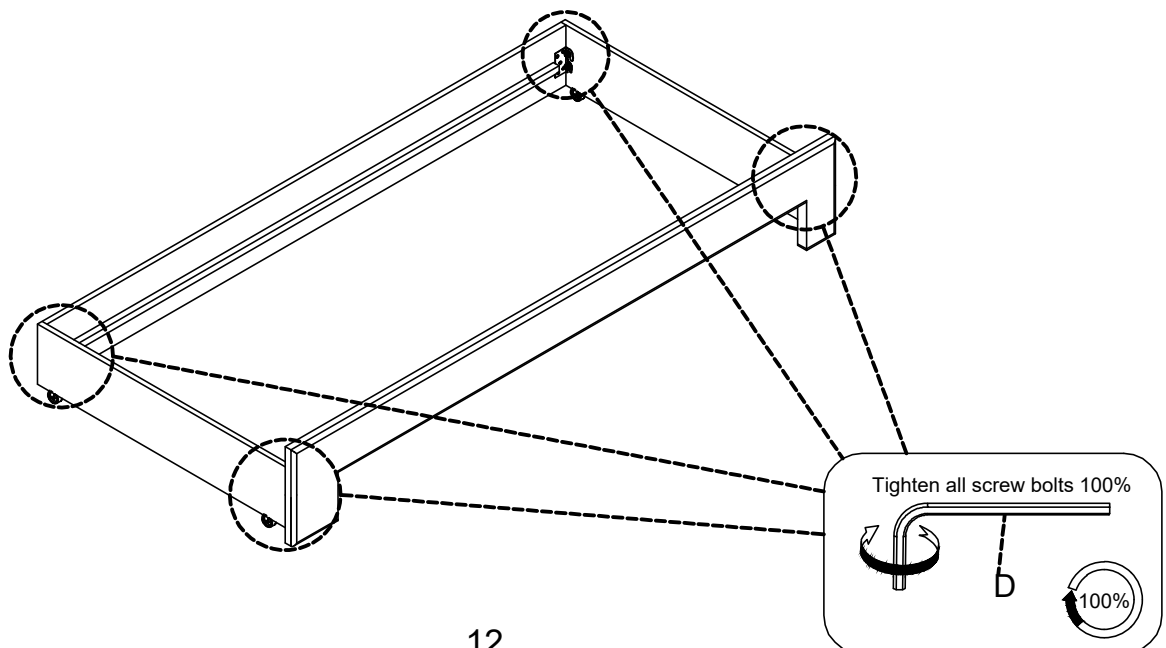
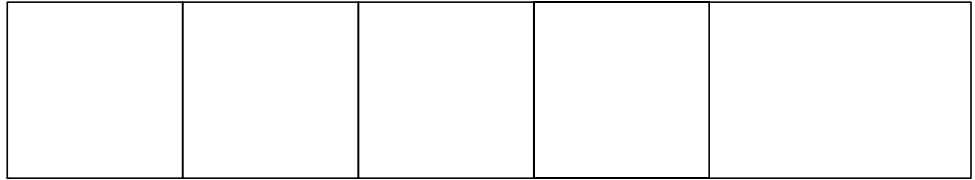

STEP 17

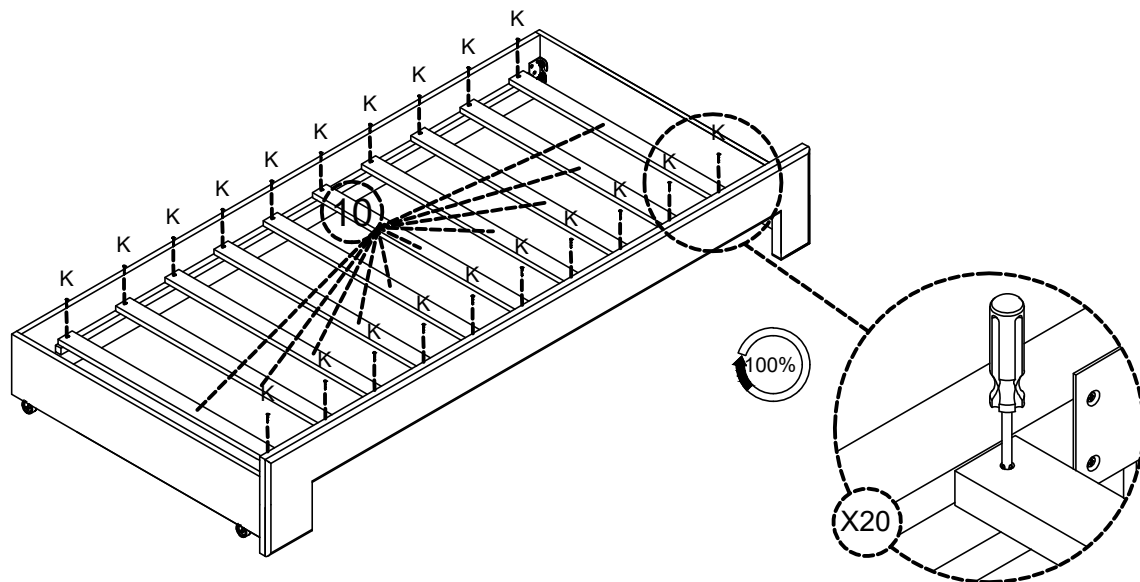
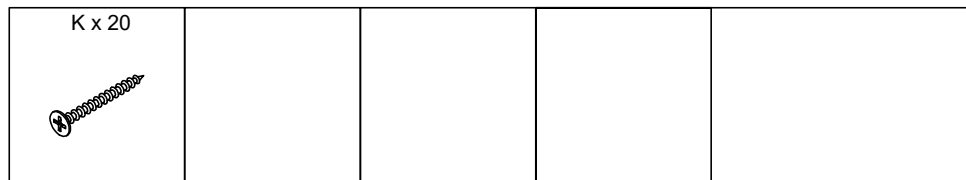

STEP 18

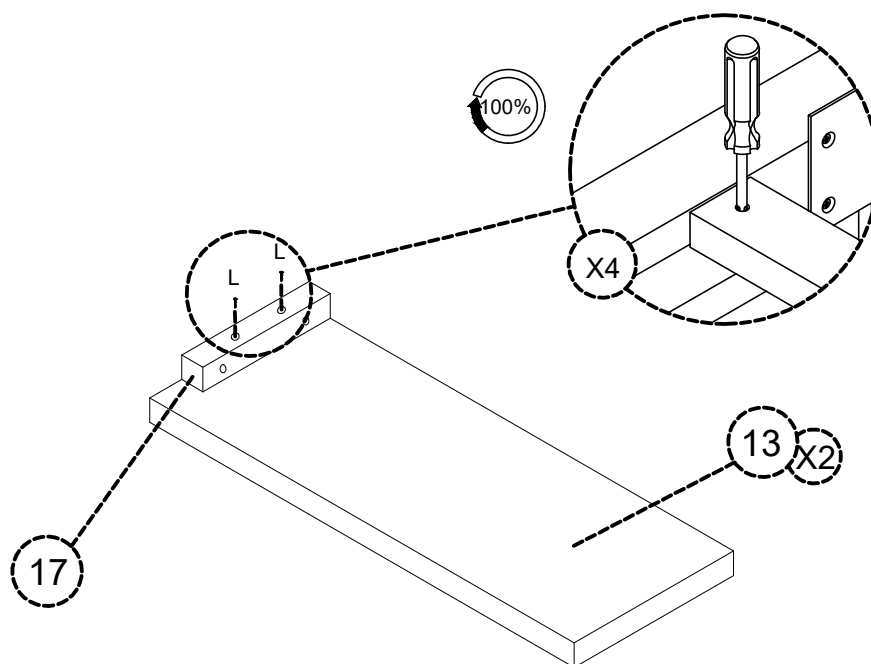
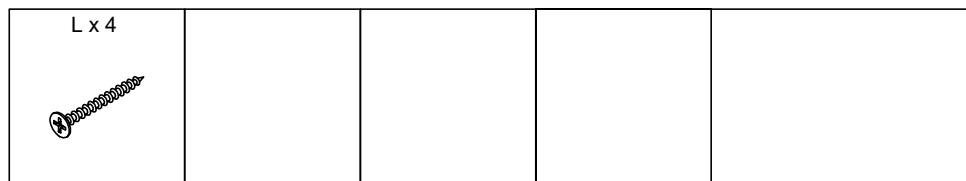

STEP 19

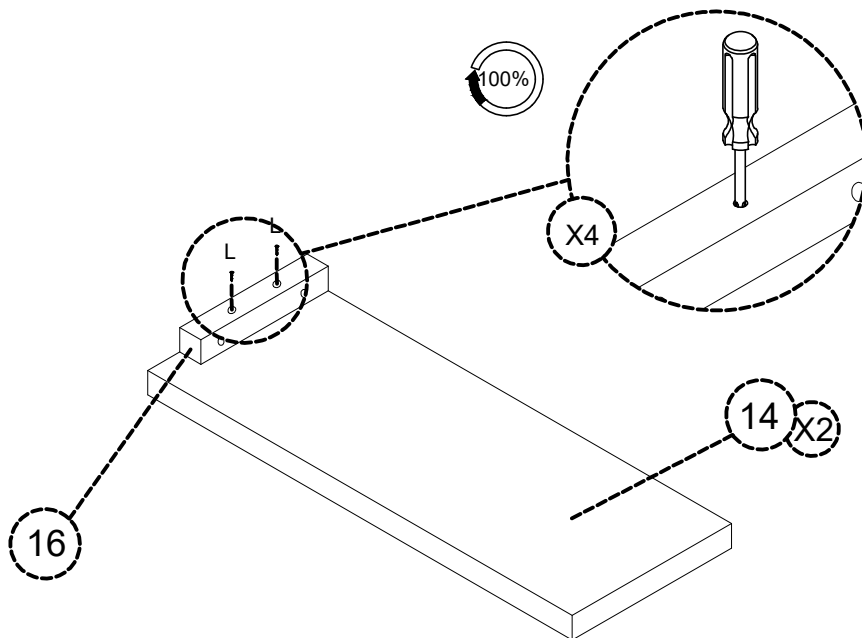
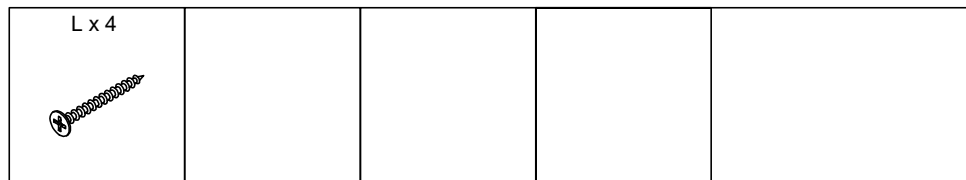

STEP 20

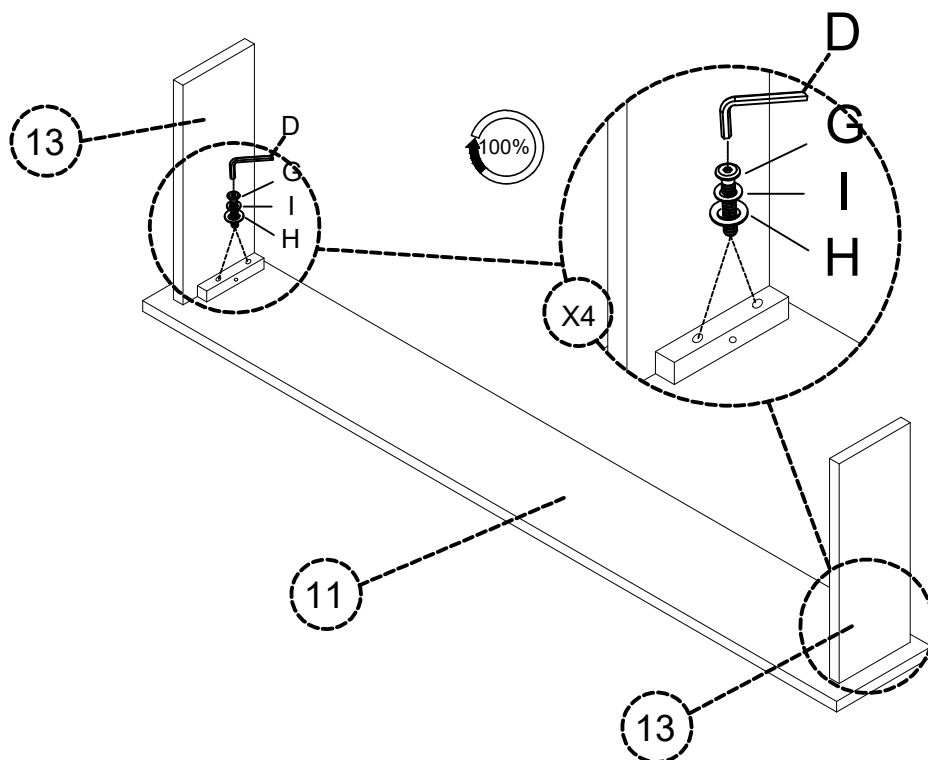
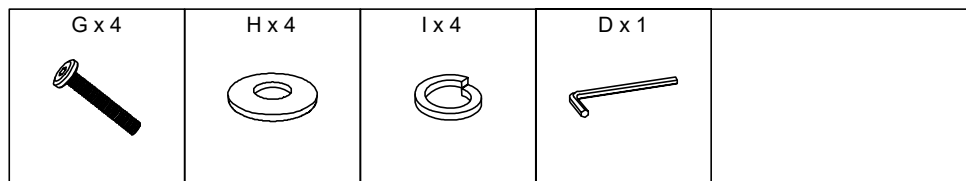

STEP 21

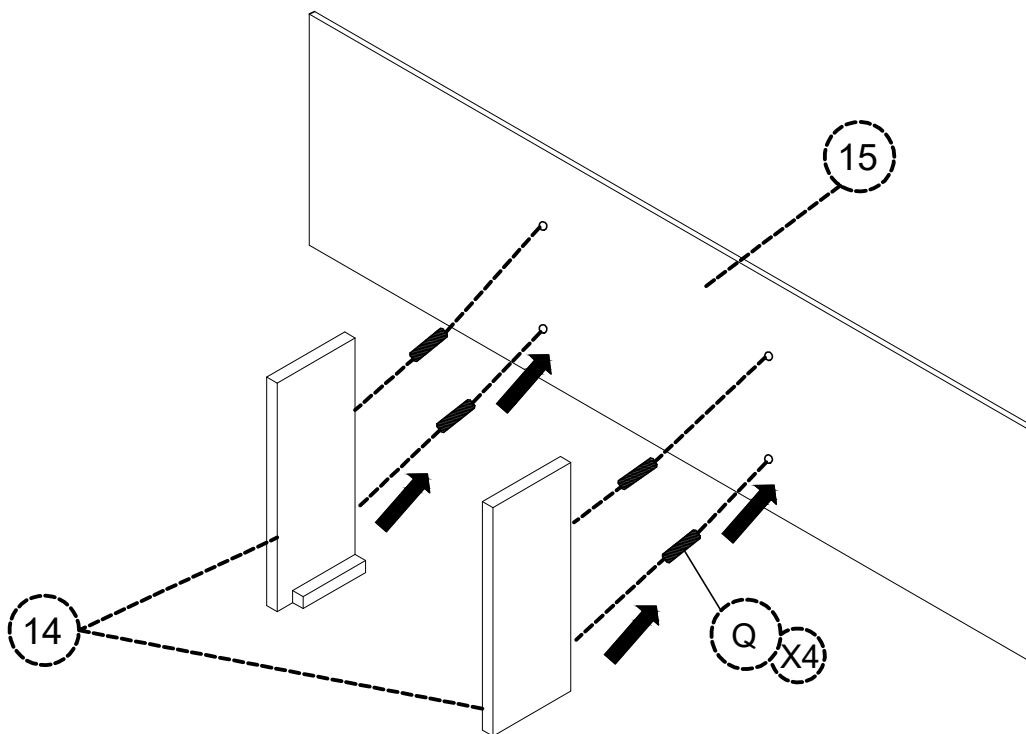
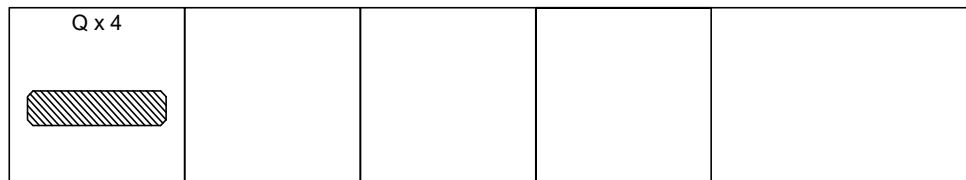

STEP 22

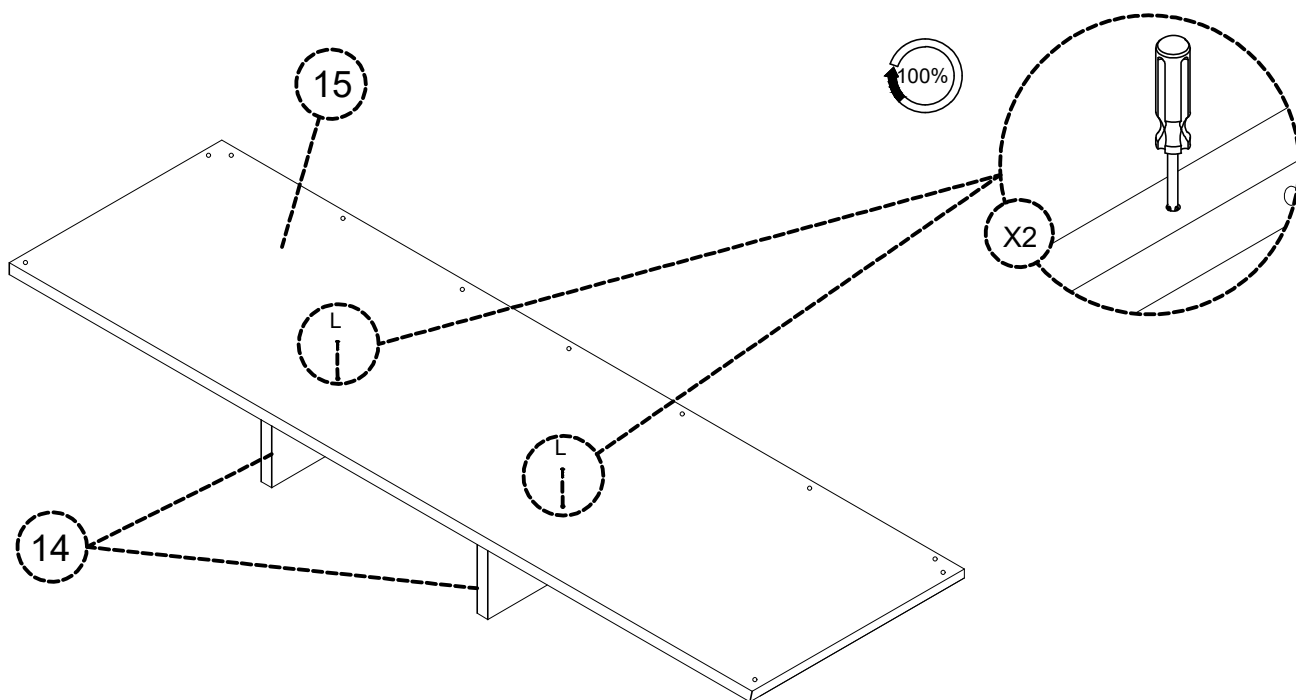
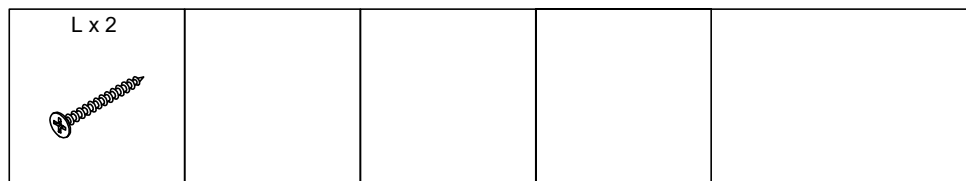

15

STEP 23

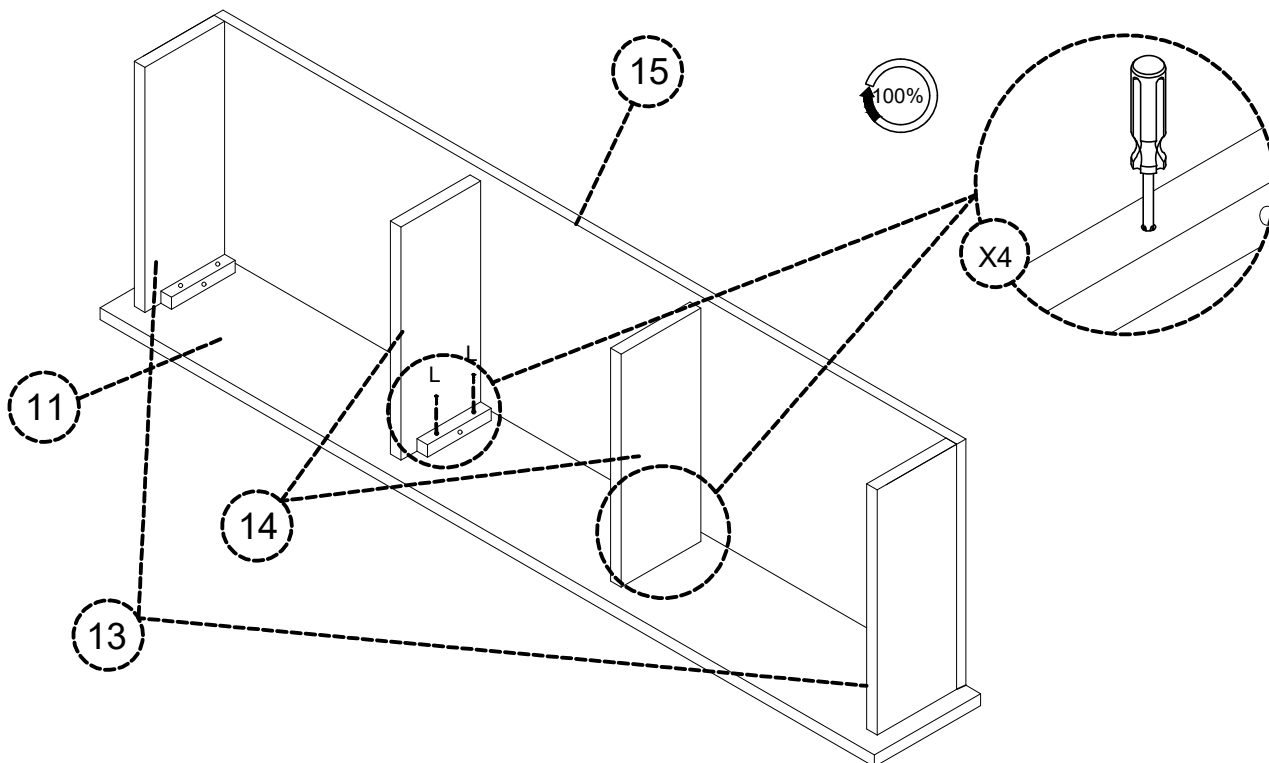
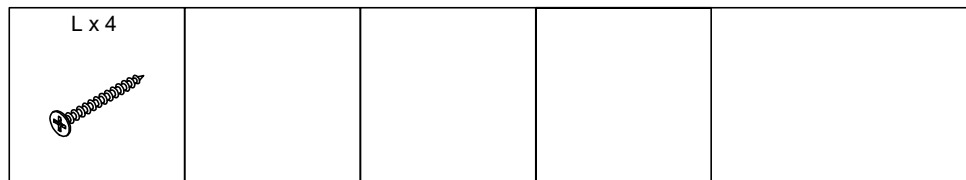

STEP 24

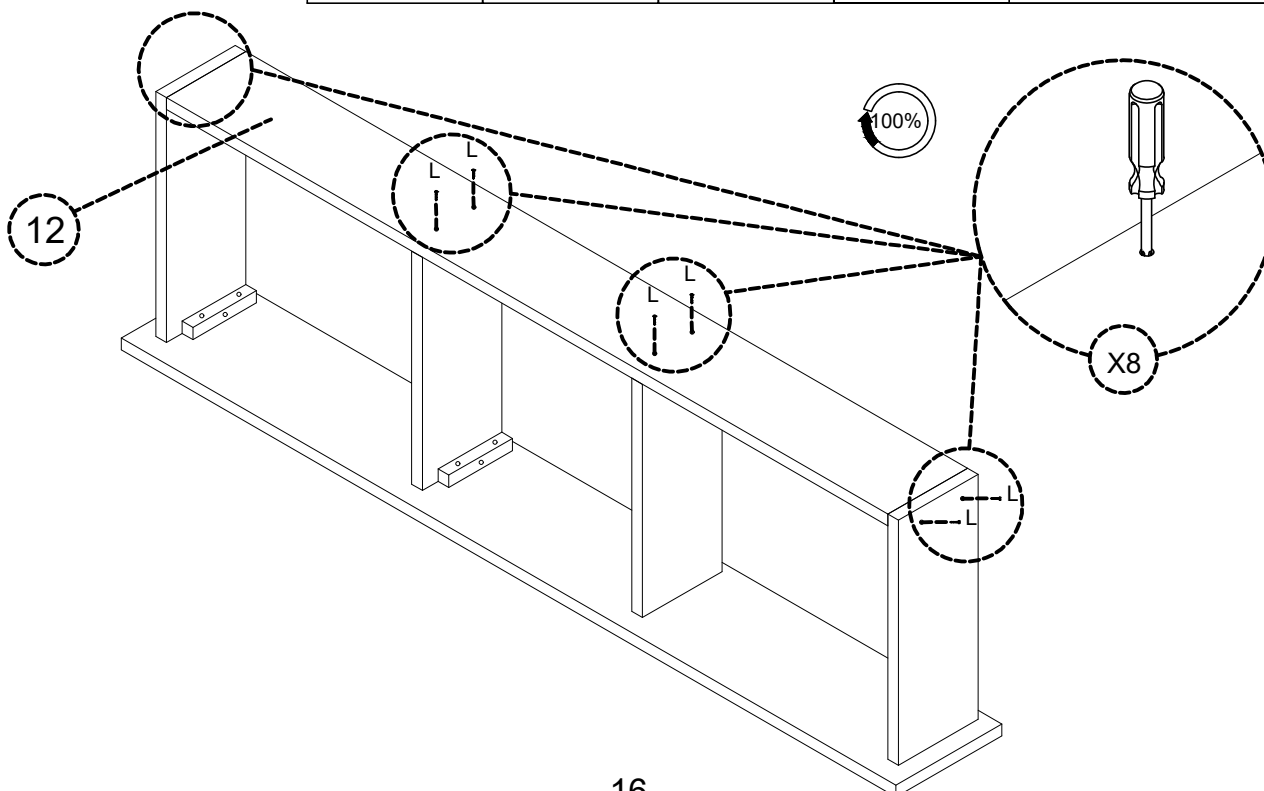
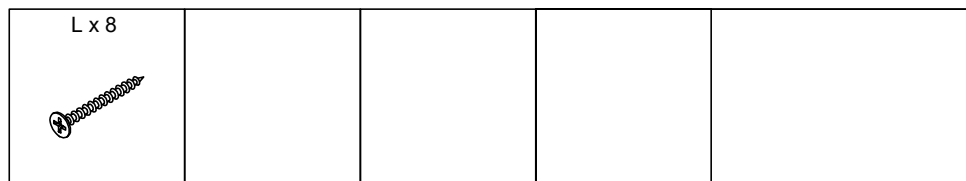

STEP 25

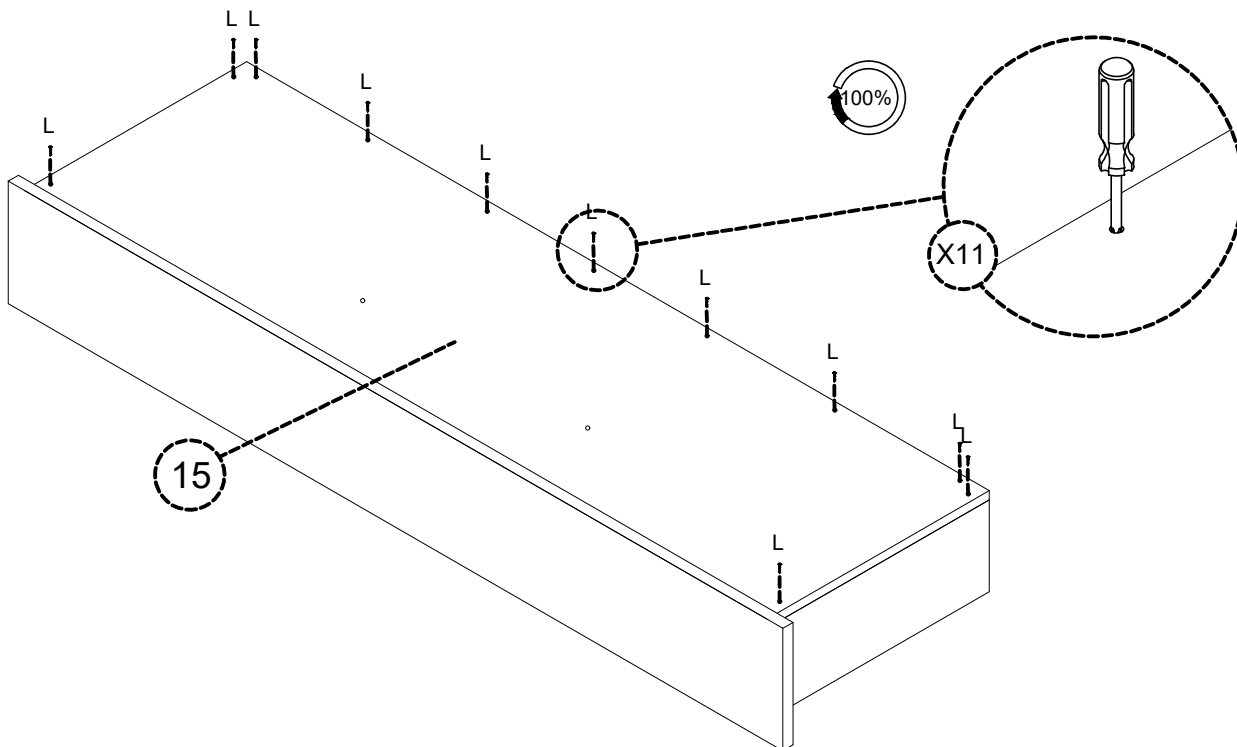
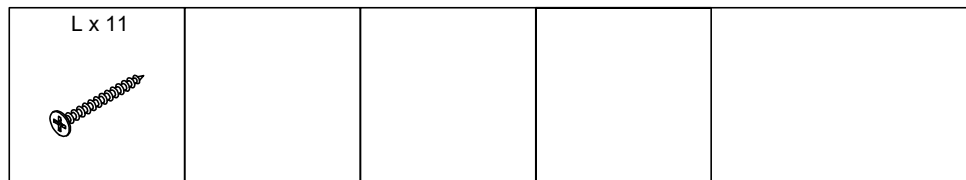

STEP 26

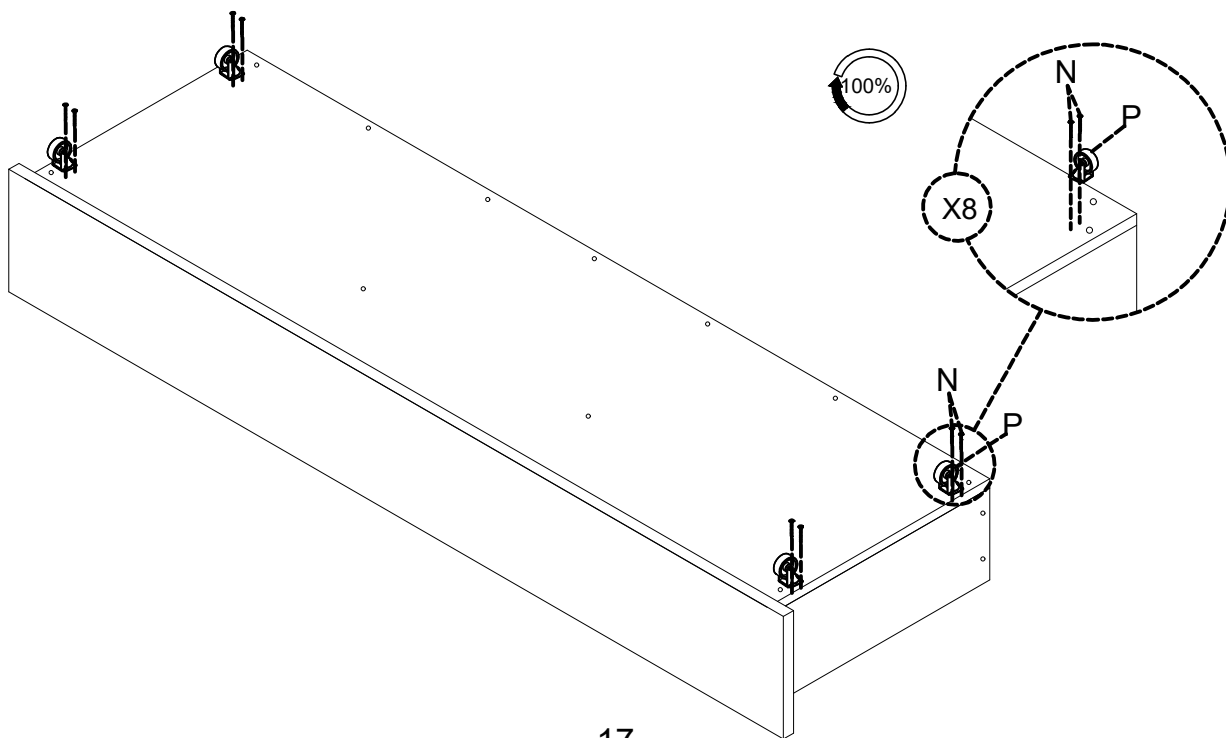
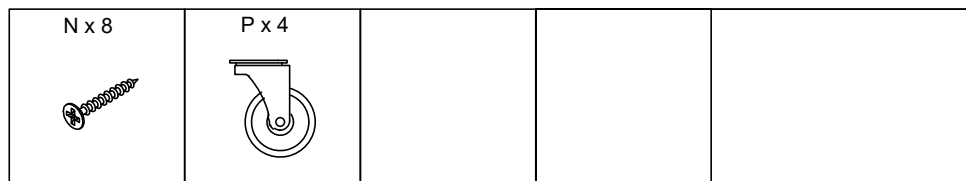

COMPLETE

