

We stand behind our brand and the quality of the items we sell. Replacement parts or products can be requested within the 1-year warranty period. Proof of purchase must be provided. This includes the date of the purchase as well as photos of the product defect. Photos are used to determine the cause of the defect and to provide future quality control. The request will be reviewed, and replacement pieces will be sent at our discretion.

# RUSTIC METAL WINDMILL STATUE

Review all assembly and care information before using this product.  
Save this manual for future reference.

Assemble components on a soft, clean surface to avoid damaging the finish.

**CAUTION: SHARP EDGES HANDLE WITH CAUTION**

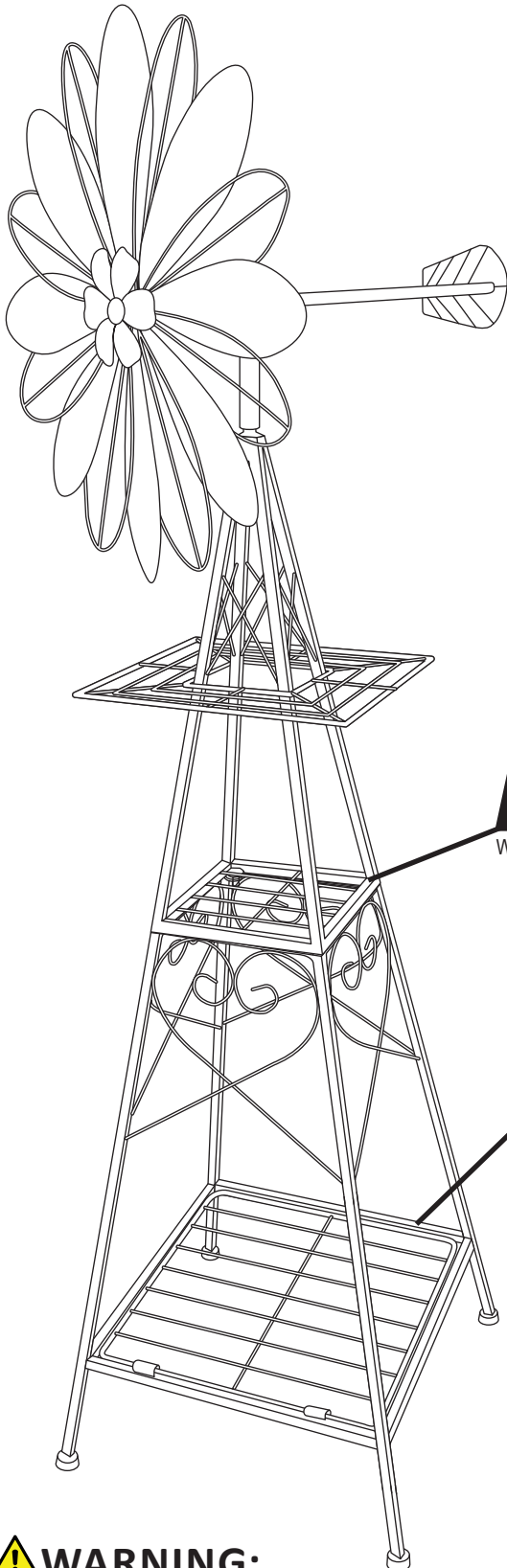







Inspect packaging to ensure all parts are accounted for before disposing of packing materials.  
Save the packing slip.

**15 pounds**  
6.8 kg  
Weight Capacity

**55 pounds**  
25 kg  
Weight Capacity

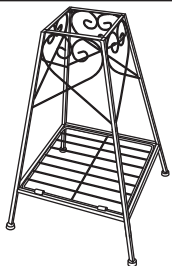
**WARNING**  
**CHOKING HAZARD** — This item contains small parts that can be swallowed. Keep children and pets away during assembly.

NO.	PARTS	QTY.
A	 Rotor Cap	1
B	 Rotor	1
C	 Rotor Tail	1
D	 Tower Top**	1
E	 Tower Base	1
F	 Platform	1
G	 Wingnut** (on bottom of part D)	2

\*\*To prevent hardware from being lost during transit, the wingnuts are loosely attached to the bottom of Tower Top (D).

**WARNING:**  
Manufacturer and seller expressly disclaim any and all liability from personal injury, property damage or loss, whether direct or indirect, or incidental, resulting from the incorrect attachment, improper use, inadequate maintenance, or neglect of this product.

# ASSEMBLY

## STEP 1

A: 1  
B: 1  
C: 1

**TIP:** The rotor cap must be secure, but not overtightened. If the blade does not spin freely, loosen the rotor cap slightly.

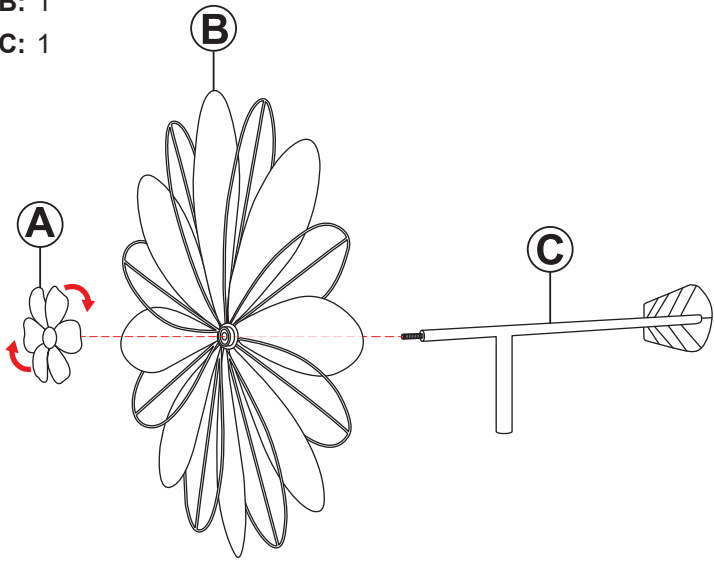

Run the threaded end of Rotor Tail (C) through the back side of Rotor (B) and secure with Rotor Cap (A).

## STEP 2

D: 1  
E: 1  
G: 2

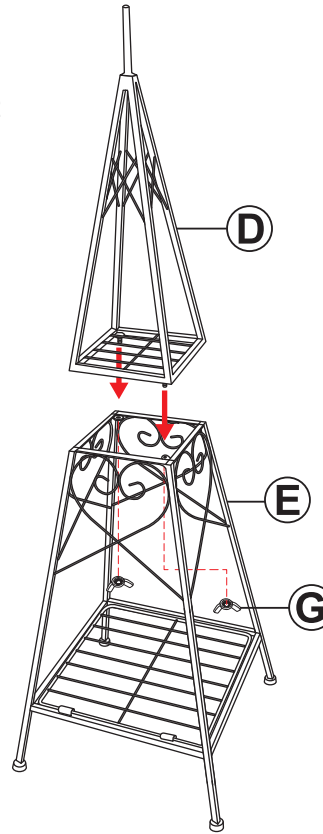

Ensuring the threaded bolts go through the mounting holes, place Tower Top (D) onto Tower Base (E).

Secure the components using two Wingnuts (E) as shown.

## STEP 3

F: 1

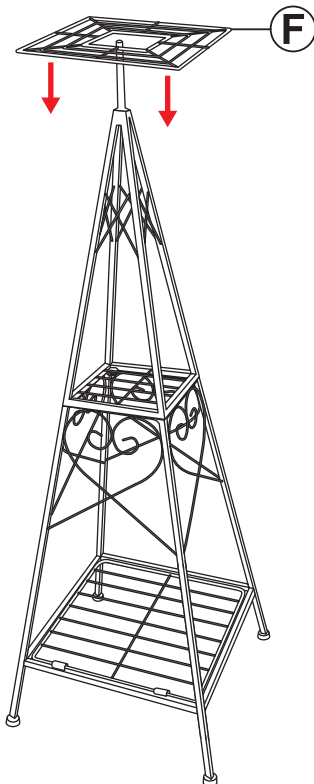

Slide Platform (F) over the top of the tower.

The platform will sit loosely on the tower; do not push down on the platform as it may cause the metal to bend and/or break.

## STEP 4

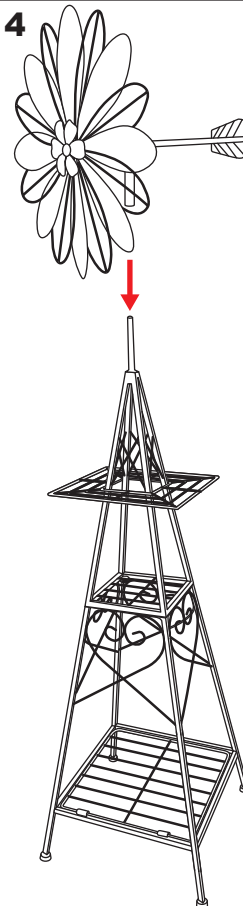

Place the assembled rotor onto the top of the tower, as shown.

# CARE & MAINTENANCE

**CLEANING:** Use a soft, dry cloth to gently wipe away dirt and debris. For stuck-on dust and dirt, dampen a soft cloth and gently wipe soiled surfaces. Do not use abrasive materials or cleaners as doing so will damage the finish and void the product warranty.

**SUN EXPOSURE:** As with any product, sun exposure will gradually fade and discolor the finish over time. This is part of the natural aging process and is not cause for return.

**WATER DAMAGE:** Over time, water will cause natural erosion to the finish and structure of this unit. Damage and degradation from exposure to water and weather elements are not covered under the product warranty.

**WINTER CARE & STORAGE:** Store in a dry, indoor location. This item was not manufactured to withstand extreme temperature changes. Do not allow water to collect or freeze on or inside the unit.

## TROUBLESHOOTING

### Rotor blades not spinning?

- Make sure the windmill is on a flat, level surface.
- Check to make sure the hardware is not over-tightened.
- The rotor is designed to spin slowly, do not force or alter the blade assembly as doing so may damage the product and void the product warranty.

## SAFETY STATEMENTS & WARNINGS

- For decorative purposes only. This item is not a toy.
- Do not allow children to use or play with this item.
- Bending the metal may cause permanent damage or breakage, and could result in serious injury.
- Do not exceed the weight capacity of the shelves.
- Do not use harsh chemicals or abrasive materials to clean this item.
- Store indoors during high-wind conditions.
- Manufacturer is not liable for damage or personal injury caused by improper use, inadequate maintenance or neglect of this product.

**Any modification to the product or failure to follow recommended care will void the product warranty.**

*If you experience issues with assembly or the product was damaged during transit, please contact our customer service team through one of the methods mentioned at the top of page 1.*

*Please have the item number and order information ready to expedite response time.*

## WARNING!

**Manufacturer and seller expressly disclaim any and all liability from personal injury, property damage or loss, whether direct or indirect, or incidental, resulting from the incorrect attachment, improper use, inadequate maintenance, or neglect of this product.**