

ASSEMBLY INSTRUCTIONS

DINING CHAIR



Weight Capacity



Philips screwdriver
not included.

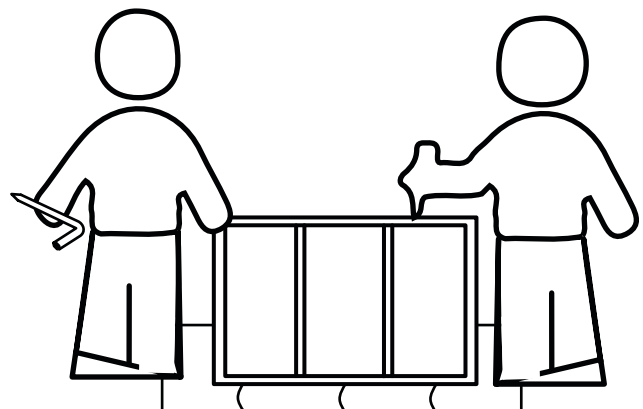
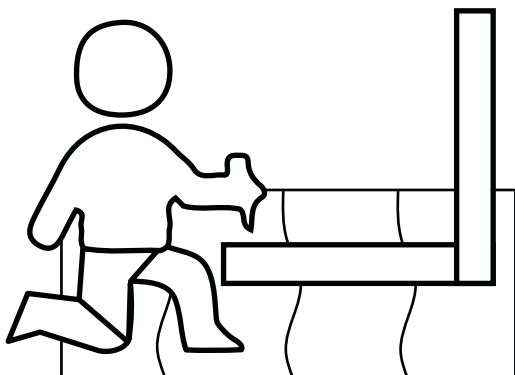
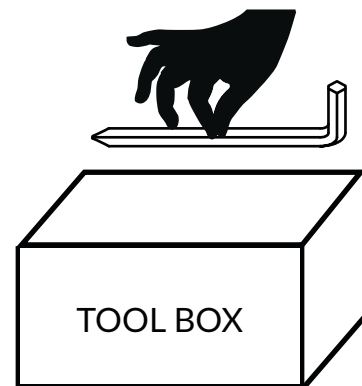

- All required tools for assembly are included unless noted.
- Locate and inspect all parts for missing items or damage prior to assembly.
- Do not dispose of packing materials until assembly is completed.
- Assemble item on a soft, clean surface to prevent damage to the item.
- Proper assembly requires 2 people.



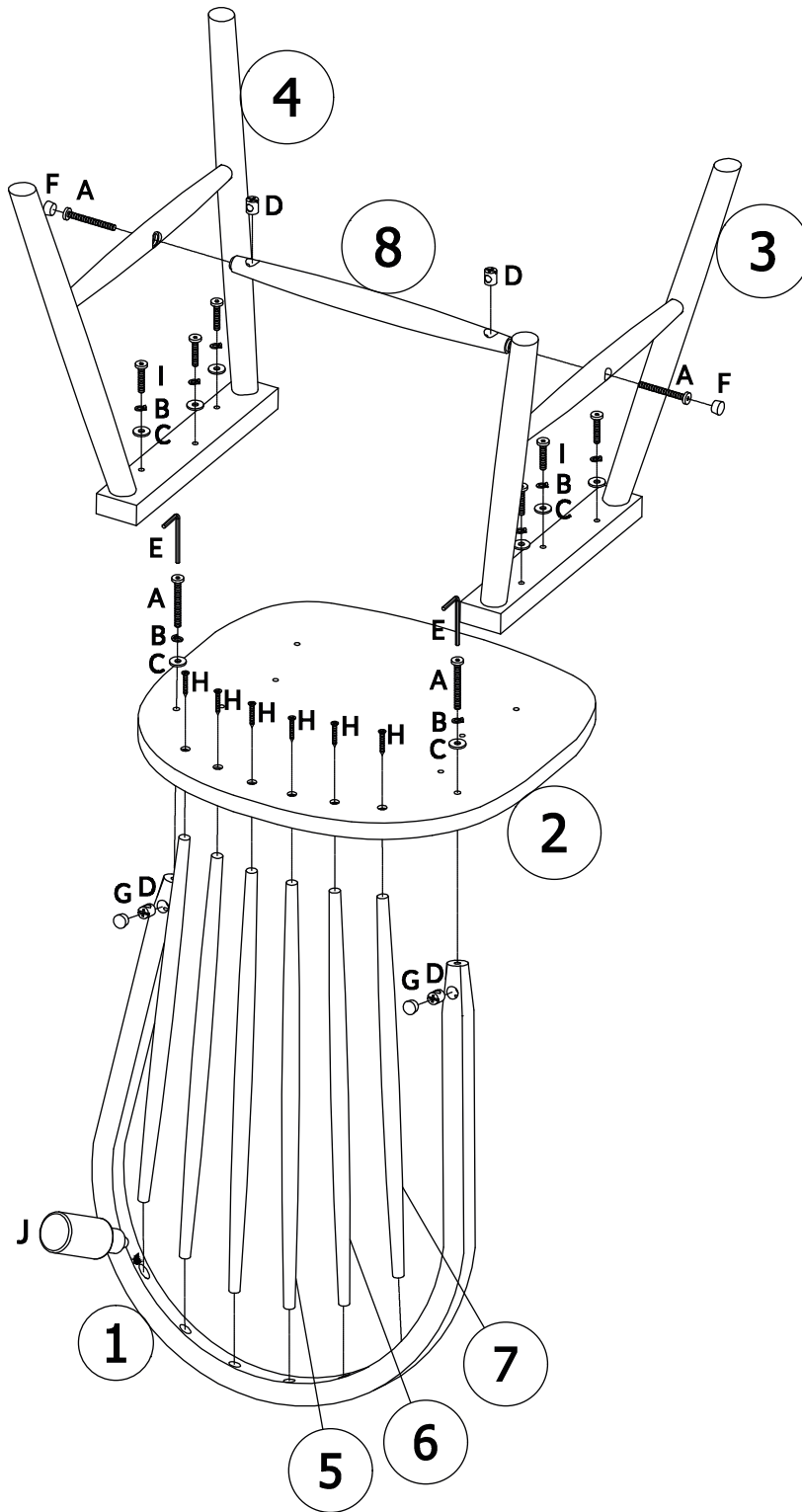

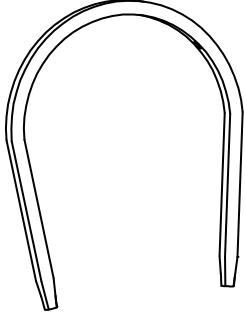
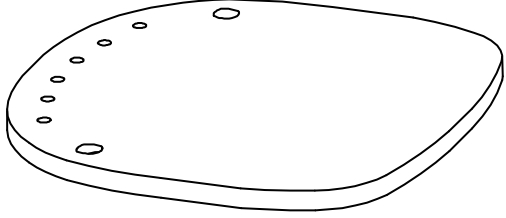
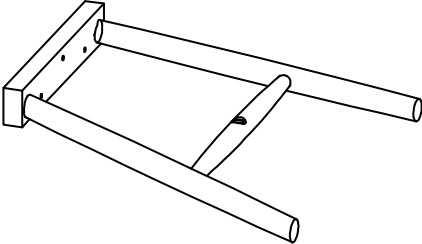
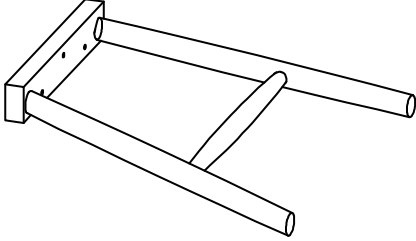

Assembly Overview

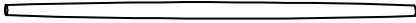
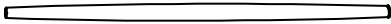
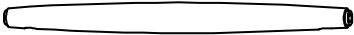



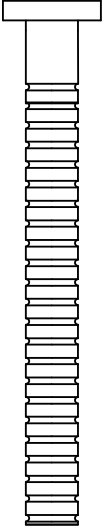

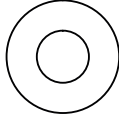
PARTS

<p>① (x1)</p>	<p>② (x1)</p>
<p>Hoop:</p> 	<p>Seat:</p> 
<p>③ (x1)</p>	<p>④ (x1)</p>
<p>Leg Frame-Left:</p> 	<p>Leg Frame-Right:</p> 
<p>⑤ (x2)</p>	<p>⑥ (x2)</p>
<p>Long Spindle:</p> 	<p>Medium Spindle:</p> 
<p>⑦ (x2)</p>	<p>⑧ (x1)</p>
<p>Short Spindle:</p> 	<p>Crossbar:</p> 

HARDWARE

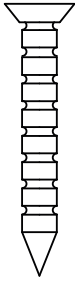
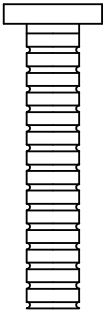
Ⓐ (x4)	Ⓑ (x8)	Ⓒ (x8)	Ⓓ (x4)	Ⓔ (x1)
				
Bolt M6x60	Spring Washer	Flat Washer	Barrel Nut M6x13	Allen Wrench

Ⓕ (x2)	Ⓖ (x2)	Ⓗ (x6)	Ⓙ (x6)	Ⓝ (x1)
				
Wood Button	Wood Button	Screw M4x30	Bolt M6x35	Glue Tube

01

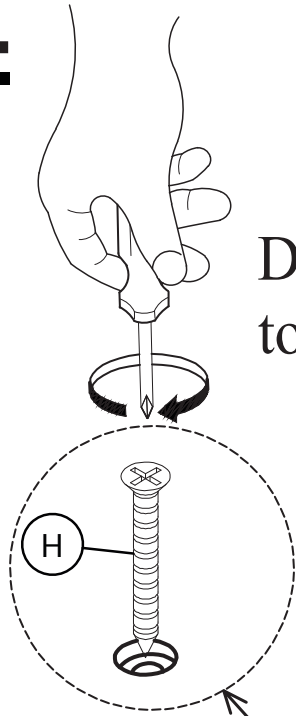

Do not use Power Tools to assemble.

6X

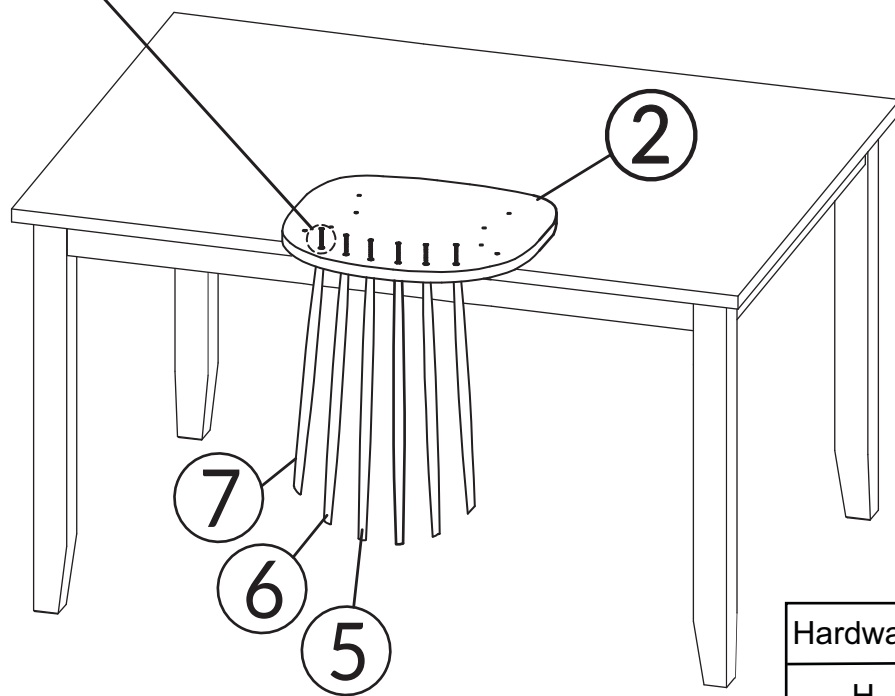

Hardware	Count
H	6

02

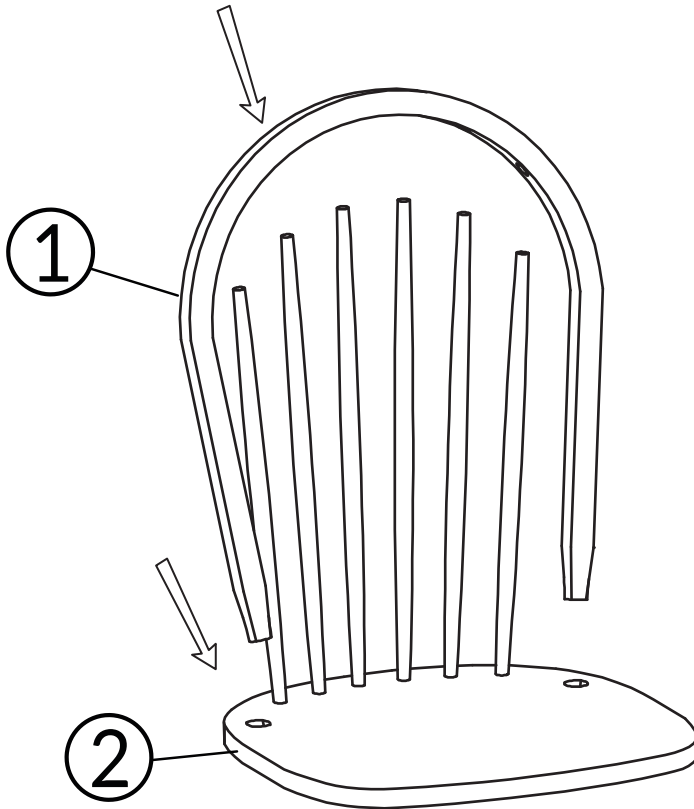
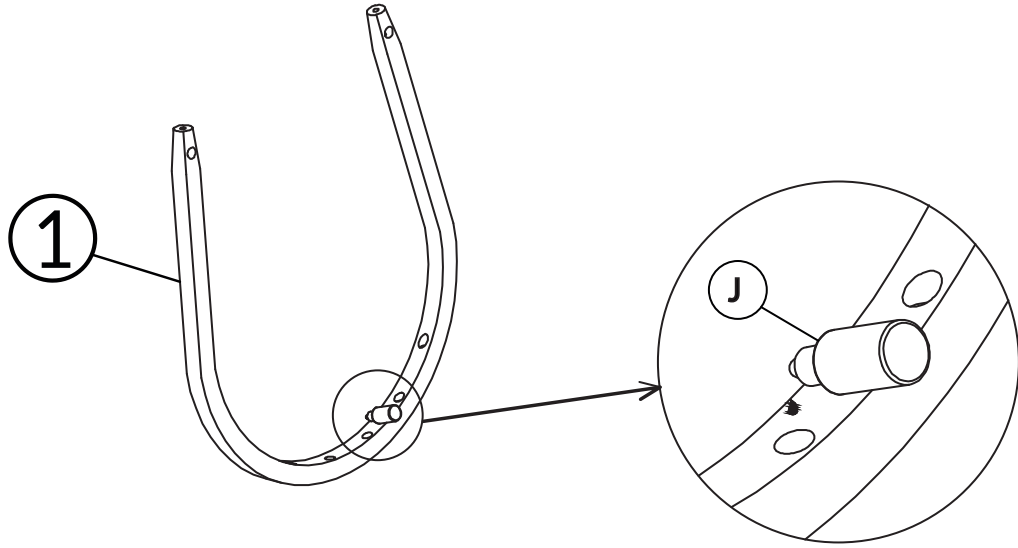

Hardware	Count
J	1

03

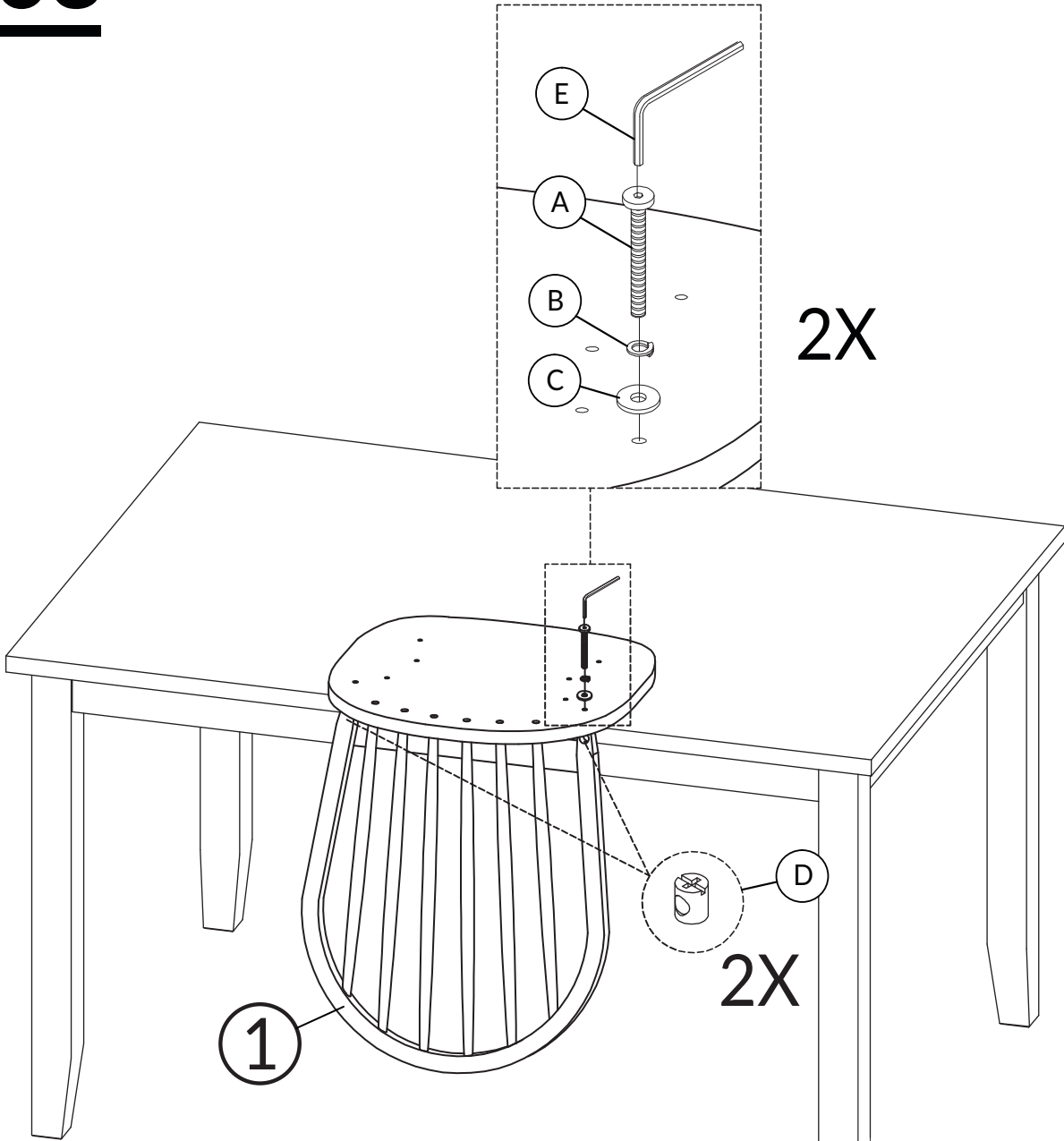

Hardware	Count
A	2
B	2
C	2
D	2
E	1

04

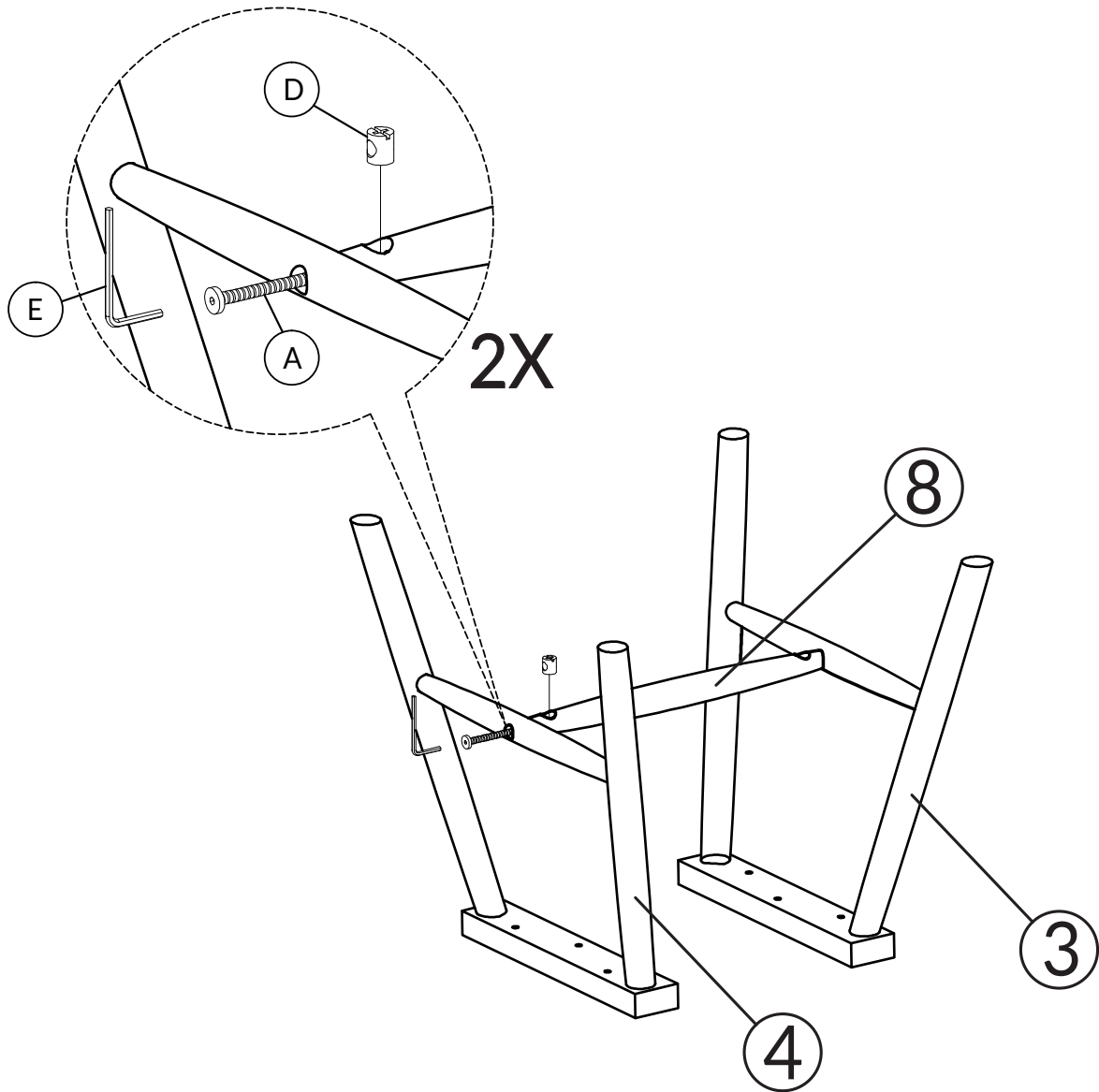

Hardware	Count
A	2
D	2
E	1

DO NOT TIGHTEN BOLT COMPLETELY.

05

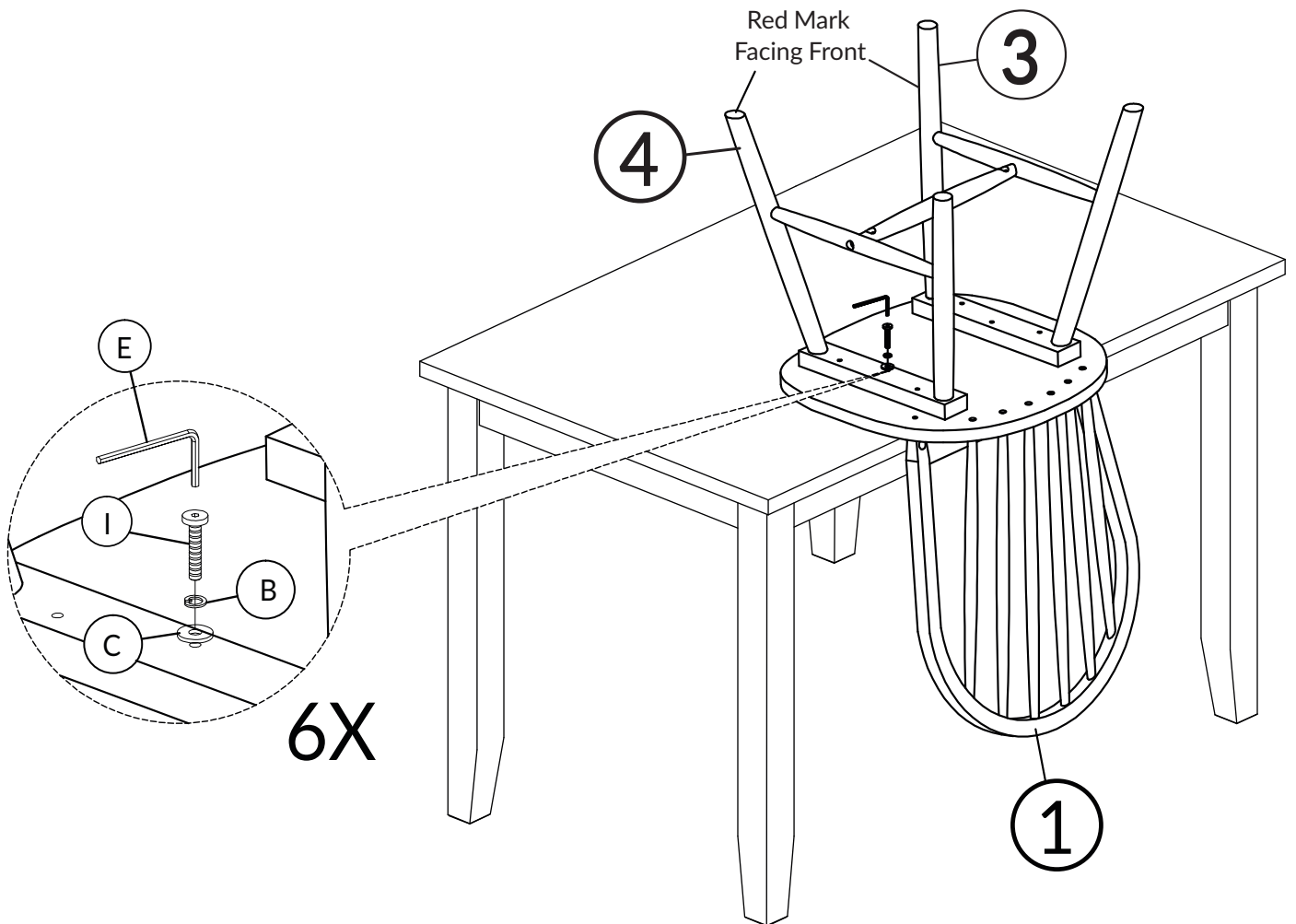

Hardware	Count
I	6
B	6
C	6
E	1

TIGHTEN BOLT COMPLETELY.

06

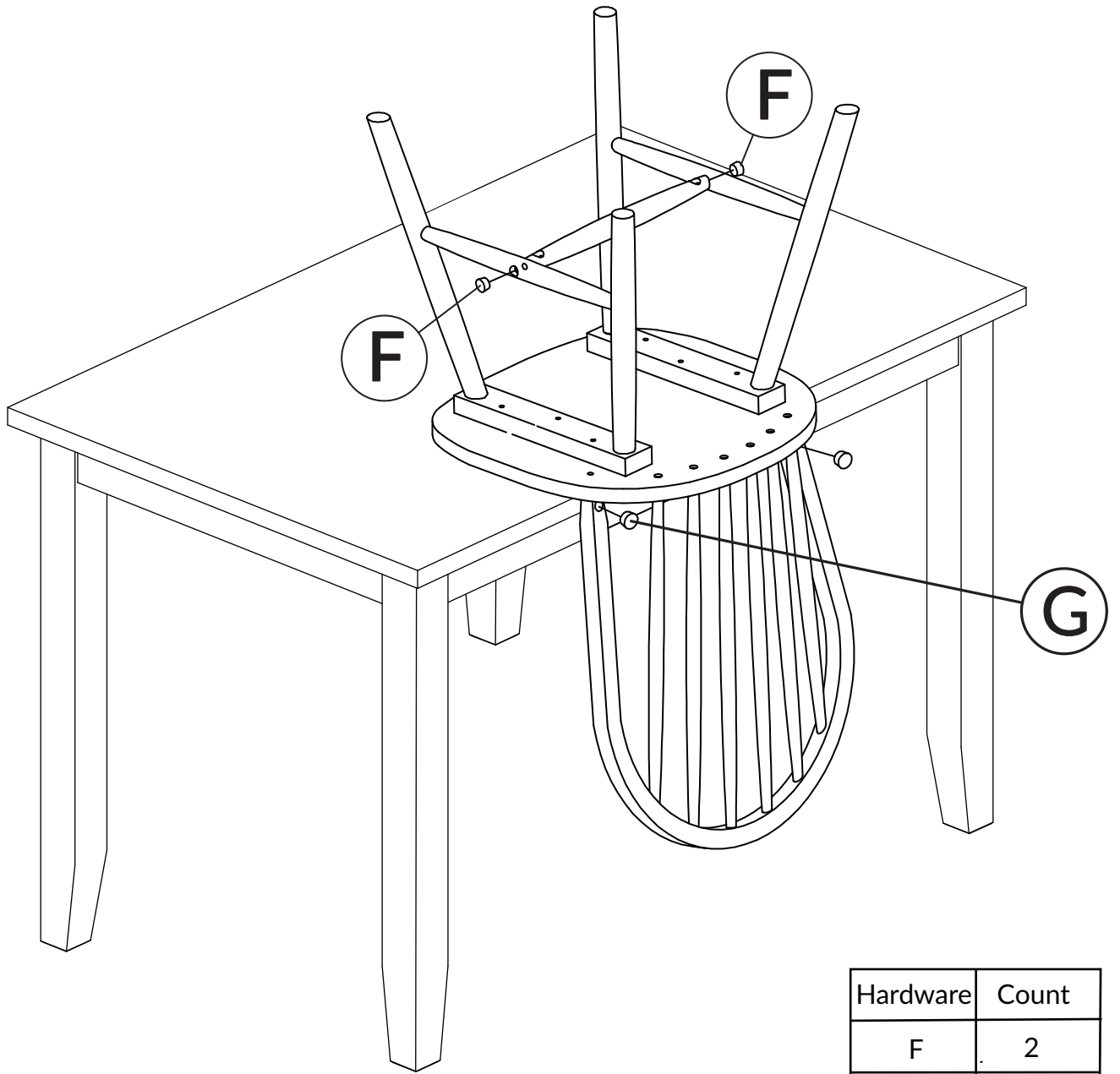

Hardware	Count
F	2
G	2

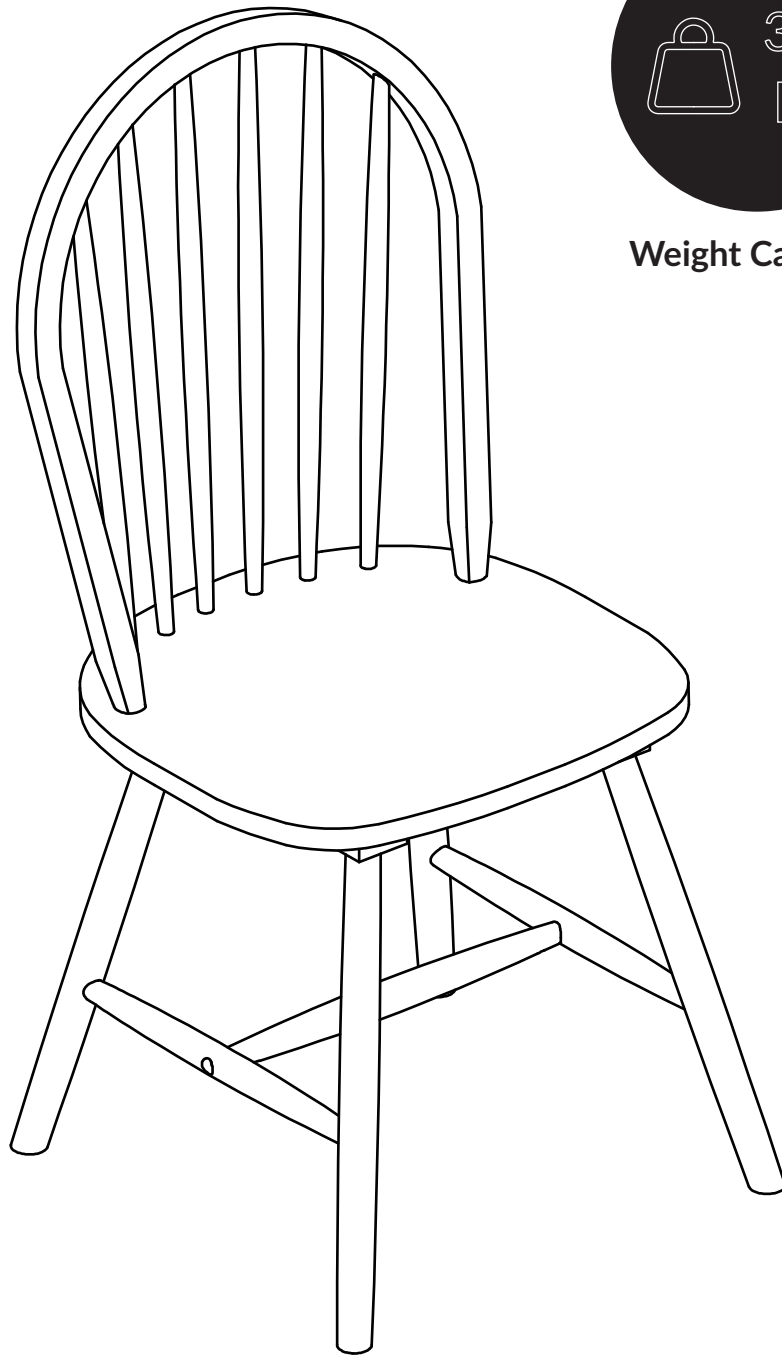

Weight Capacity

BE SURE TO CHECK ALL BOLTS ARE SECURELY TIGHTENED PRIOR TO USE.