

# Rails wood installation

Rails (VR; no collars) Installation Instructions

## Starter Kit Included Parts

- (2) Rails
- (1) Wood Lags
- (1) Hex Key or 2 Nuts

## Required Tools

- Level
- 2x10mm or adjustable wrenches
- Drill
- 5/32" drill bit (4mm)

**Important Note:** These installation instructions are only for attaching Rails to solid wood or plywood surface with a minimum thickness of 1/2" (12.7mm).

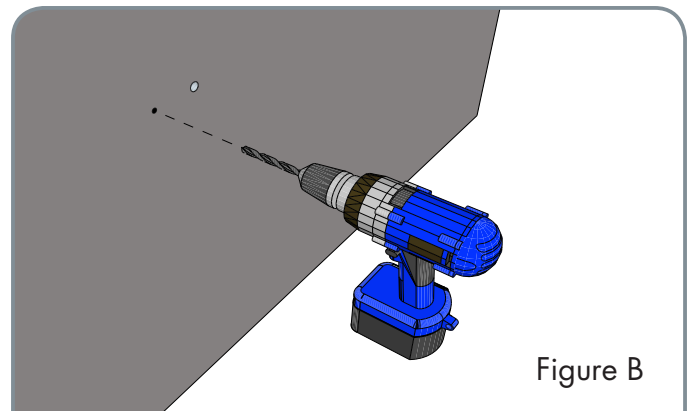
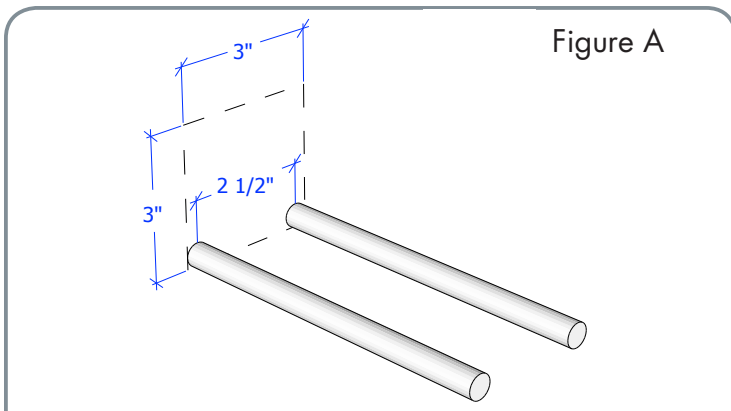

## 1. Mark the mounting hole locations

Mark the center-point of the first rail and, using the level to ensure the marks are on the same horizontal plane, marker the center-point of the second rail 2.5 inches (64.5mm) away.

## 2a. Install the Wood Lag using M6 Drill Bit or Hex Key

Using either the provided hex key or optional M6 drill bit, drive the wood lag into the pilot holes until the coarse threads are no longer visual.

If using a hex key and the wood is too knotty or hard to drive the wood lag, see step 2b.

**Pro tip:** Go slowly and ensure the wood lags remain level and straight.

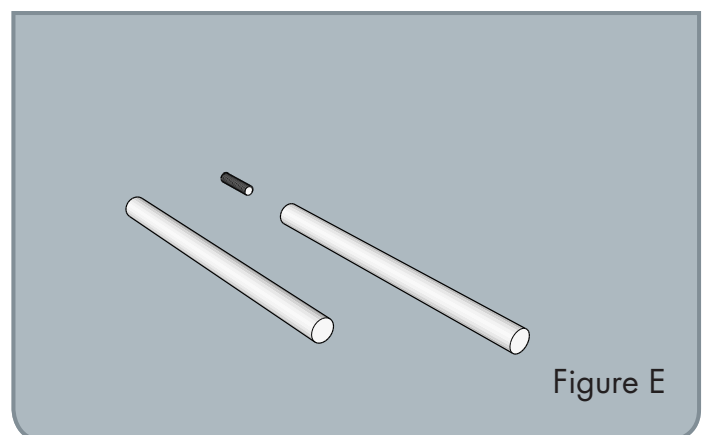
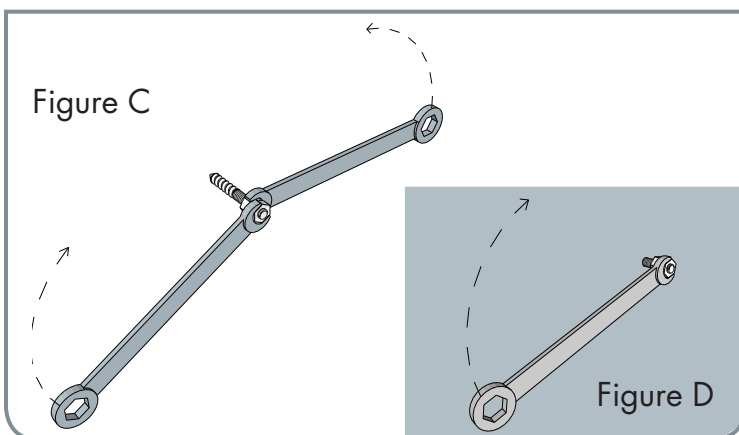

## Instructions: wood install

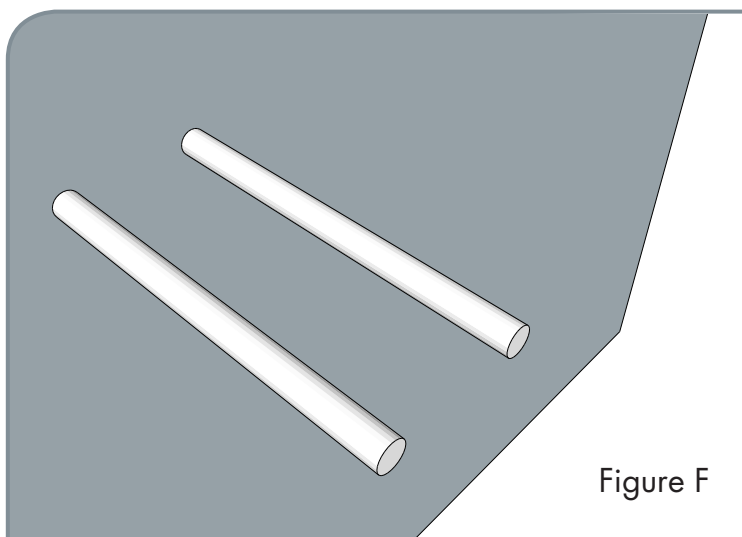

### 2b. Install the Wood Lag using Nuts

Thread the 2 nuts provided onto the fine threaded end of each wood lag. Using two 10mm wrenches, tighten the nuts against one another (Figure C), essentially creating a screw head. Then use one wrench on the outer nut and screw the wood lag into the pilot holes until the coarse threads are no longer visible.

### 3. Install Rails

Screw a Rail Mag clockwise onto an anchor and firmly hand-tighten in place (Figure E). Repeat the process for the second Rail.

### 4. Add Wine

Only the good stuff

### Additional Notes:

All installations into drywall require the use of collars and alternate fasteners to properly support the Rails. This specific design is meant to hold Champagne and Magnum bottles. Any application outside of these parameters is not warranted by VintageView and may result in product and/or installation failure, property damage and/or bodily injury.

### Maintenance and Care:

Rails should be regularly checked for tightness. Should any party to be found to be loose, tighten by hand until secure. If the face of the wall surface shows signs of breakage, discontinue use immediately until the wall may be adequately repaired. Pins may be cleaned with a damp cloth and mild dish soap -abrasive pads or steel wool should NOT be used as they will damage the finished surfaces of the parts

# Rails drywall installation

Rails (VRC; with collars) Installation Instructions

## Starter Kit Included Parts

- (2) Rails
- (2) Rails Collars
- (2) Toggle Bolts
- (2) Machine/Lag Studs
- (1) Hex Key (2.5mm) or 2 Nuts

## Required Tools

- Level
- 2x10mm or adjustable wrenches
- Drill
- 5/32" drill bit (4mm)

**Important Note:** These installation instructions are only for attaching Rails to solid wood or plywood surface with a minimum thickness of 1/2" (12.7mm).

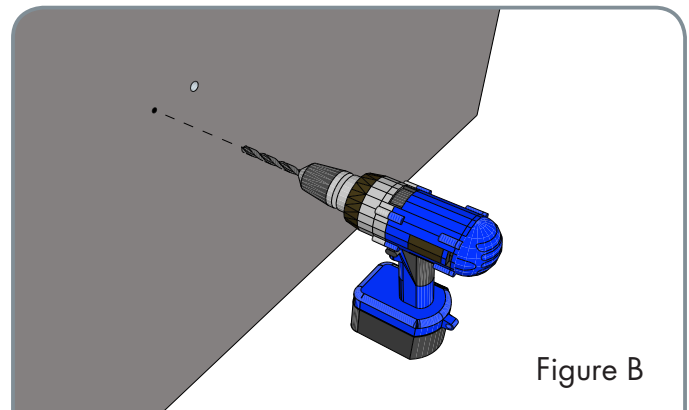
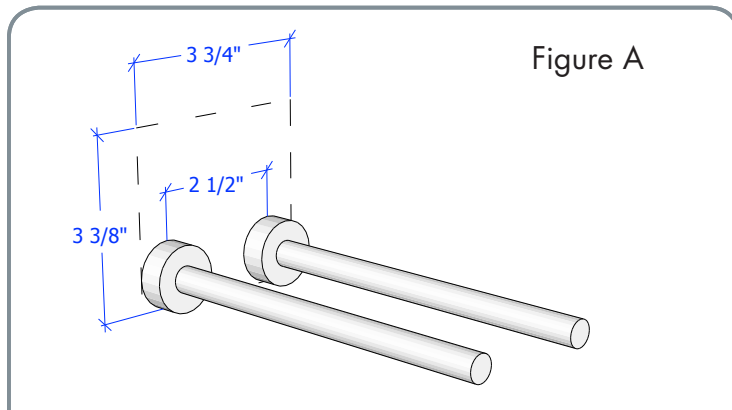

## 1. Mark the mounting hole locations

Mark the center-point of the first rail and, using the level to ensure the marks are on the same horizontal plane, mark the center-point of the second rail 2.5 inches (64.5mm) away.

## 2. Drill mounting holes

Using the smaller drill bit, drill a pilot hole to determine if drywall or wood hardware is needed for installation. If the surface is determined to be wood, drill remaining pilot holes at the marked locations and move to step 3b. If it is determined to be drywall, use the 5/8" drill bit to drill holes in marked locations

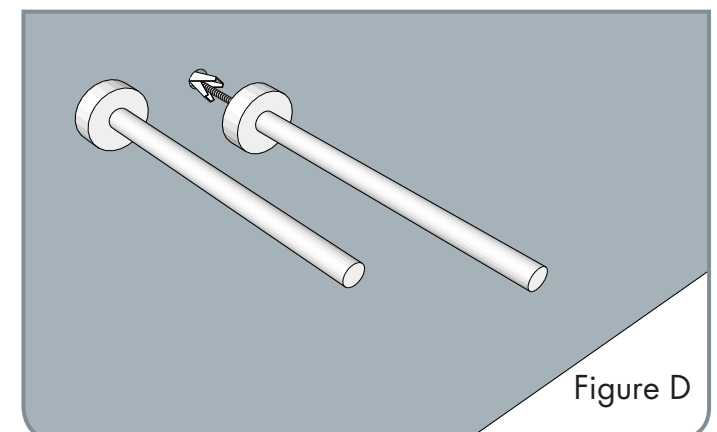
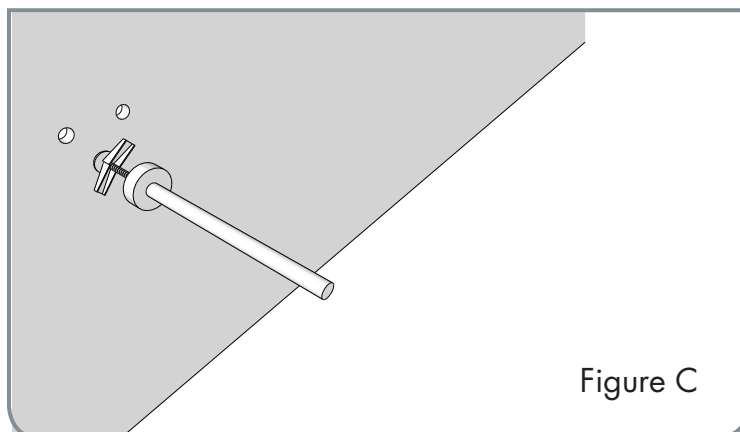

**3a. Install Rails (for drywall)** Disassemble provided toggle bolts, removing each expanding nut. Insert the bolt through the mounting hole on the wall bracket. With the wings of the expanding bolt oriented toward the bolt head, thread the nut onto the bolt until it begins to protrude from the nut by 1/2".

Slide the collar onto the bolt and screw the bolt into the threaded end of the Rail. Push the head of the bolt through the drywall until the Rail Collar is flush against the wall surface. Ensure that both wings of the nut have fully expanded on the back side of the wall and gently pull back on the Rail to hold the wings of the expanding nut against the back side of the drywall.

## Instructions: drywall install

### 3a. Install Rails (continued)

Center the bolt in the anchor hole and turn the Rail clockwise to firmly hand-tighten in place. Repeat the process for the second rail and use a level to ensure they are both level.

### 3b. Install Rails (for wood)

Using either the provided hex key or optional M6 drill bit, drive the wood lag into the pilot holes until the coarse threads are no longer visible. If using a hex key and the wood is too knotty or hard to drive the wood lag see the next step.

Thread the 2 nuts provided onto the fine threaded end of each wood lag. Using two 10mm wrenches, tighten the nuts against one another, essentially creating a screw head. Then use one wrench on the outer nut and screw the wood lag into the pilot holes until the coarse threads are no longer visible.

Slide a collar over the stud protruding from the wall and thread a Rail onto the stud extending from the wall and firmly hand tighten.

## 4. Add Wine

Only the good stuff

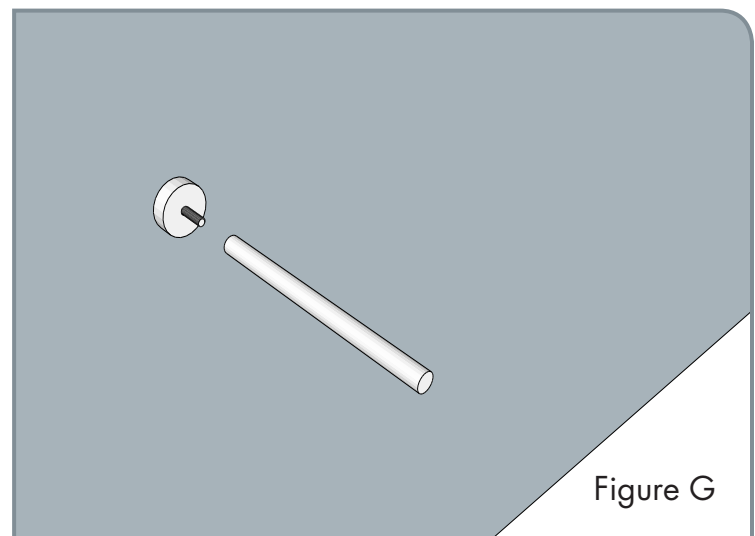
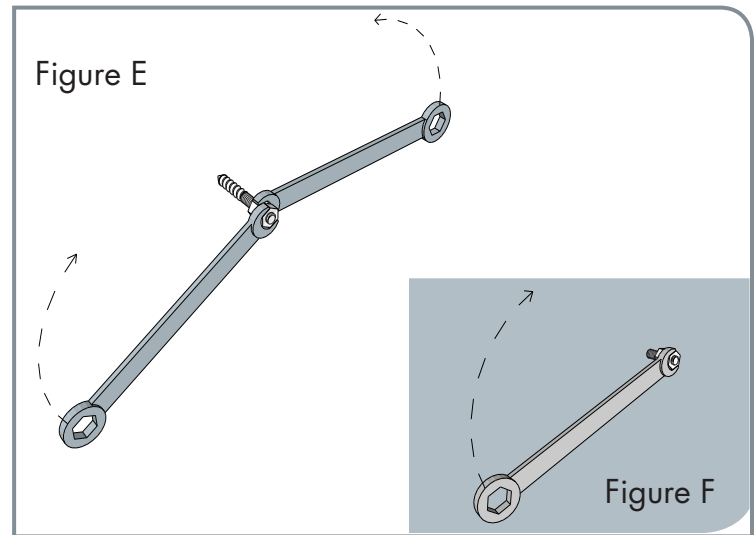

### Additional Notes:

All installations into drywall require the use of collars and alternate fasteners to properly support the Rails. This specific design is meant to hold Champagne and Magnum bottles. Any application outside of these parameters is not warranted by VintageView and may result in product and/or installation failure, property damage and/or bodily injury.

### Maintenance and Care:

Rails should be regularly checked for tightness. Should any party to be found to be loose, tighten by hand until secure. If the face of the wall surface shows signs of breakage, discontinue use immediately until the wall may be adequately repaired. Pins may be cleaned with a damp cloth and mild dish soap -abrasive pads or steel wool should NOT be used as they will damage the finished surfaces of the parts