

6 CUBE STORAGE CUBE WITH BACK

Assembly instruction- Please keep for future reference

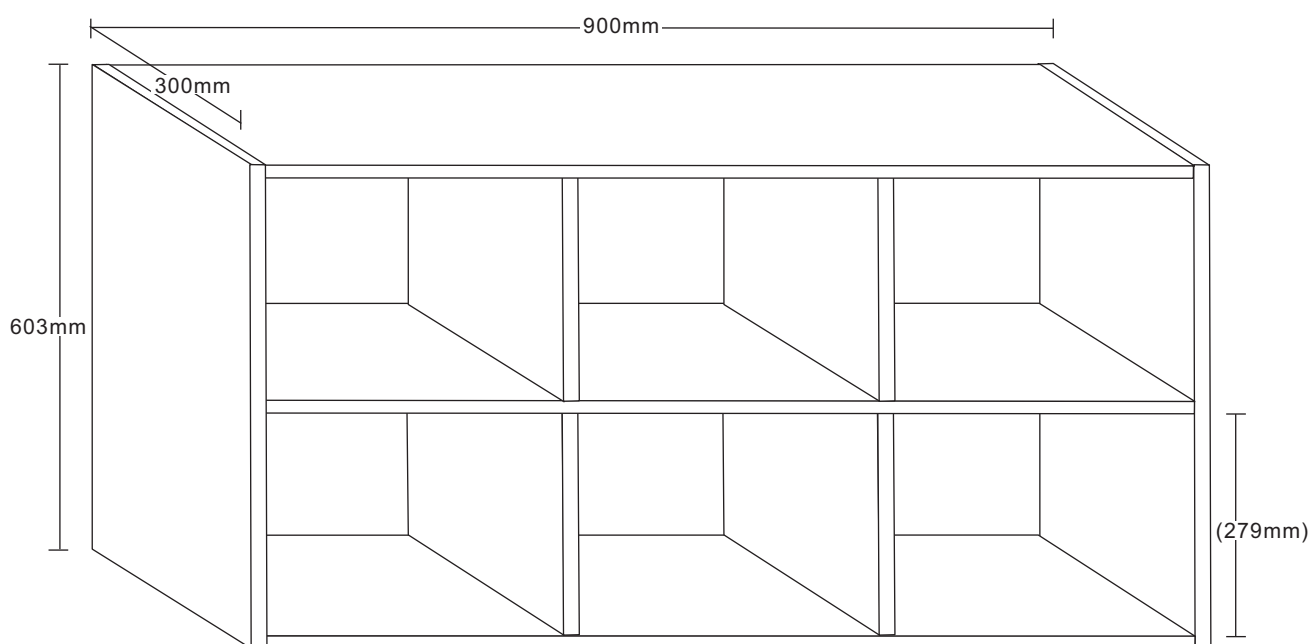

Width: 90 cm
Depth: 30 cm
Height: 60 cm



45 mins
(approx)

Important

- PLEASE READ THESE INSTRUCTION FULLY BEFORE STARTING ASSEMBLY.
- PLEASE DO NOT THROW THE PACKAGING AWAY UNTIL YOU ARE SATISFIED WITH PURCHASE, GOODS NEED TO BE RETURNED IN ORIGINAL PACKAGING.

⚠ Safety and Care Advice

Important-Please read these instructions fully before starting assembly

- Check you have all the components and tools listed on pages 2,3 and 4.
- Remove all fittings from the plastic bags and separate them into their groups.
- Keep children and animals away from the work area, small parts could choke if swallowed.
- Make sure you have enough space to lay out the parts before starting.
- Do not stand or put weight on the product, this could cause damage.
- Assemble the item as close to its final position (in the same room) as possible.
- Assemble on a soft, level surface to avoid damaging the unit or your floor.
- We do not recommend the use of power drill/drivers for inserting screw, as this could damage the unit. only use hand screwdrivers.
- Dispose of all packaging carefully and responsibly.



Care and Maintenance

- Only clean using a damp cloth and mild detergent, do not use bleach or abrasive cleaners.
- From time to time check that there are no loose screws on this unit.
- This product should not be discarded with household waste. Take to your local authority waste disposal centre.

Components - Panels

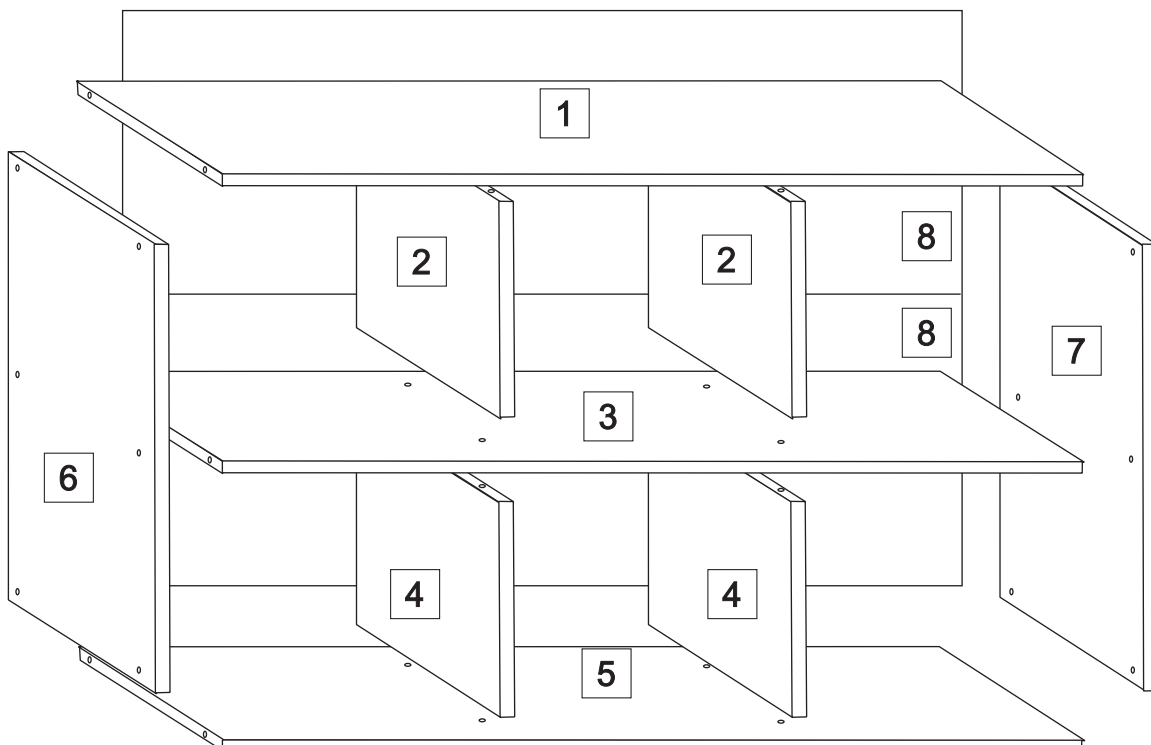





Components - Fixings





Please check that you have all the components listed below before constructing your item.

Note: The quantities below are the correct amount to complete the assembly. In some cases more fittings may be supplied than are required.

HARDWARE

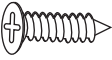
<p>(A)</p>  <p>JCBC M5 X 40mm X 12</p>	<p>(B)</p>  <p>Dowel (M8X25) X 16</p>	<p>(C)</p>  <p>Leg Pin X 8</p>	<p>(D)</p>  <p>Nail X 40</p>	<p>(E)</p>  <p>Allen Key X 1</p>
---	--	---	---	---

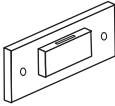
ANTI - TIPPING KITS

<p>(F)</p>  <p>M4 X 32mm X 4</p>	<p>(G)</p>  <p>M3.5 X 20mm X 4</p>	<p>(H)</p>  <p>Wall Plug X 4</p>	<p>(I)</p>  <p>Bracket X 4</p>	<p>(J)</p>  <p>Strap X 2</p>
---	---	---	---	---

Tools Required (Not Provided)



Ruler - Use this to measure your screws (mm)

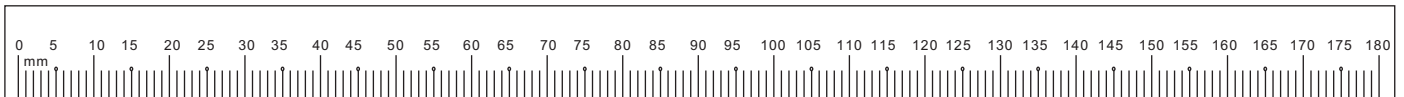

Important-Please read these instructions fully before starting assembly

Assembly Instructions

Step 1

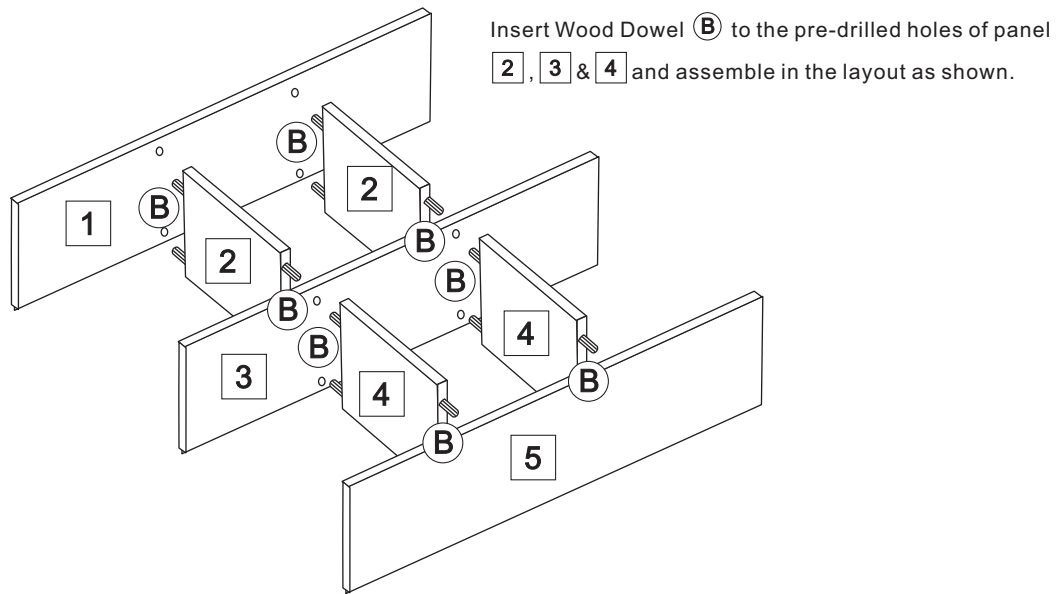

Step 2

Attach Part 6 & 7 to assemble the cube with JCBC Screw (A) and tighten using Allen key.

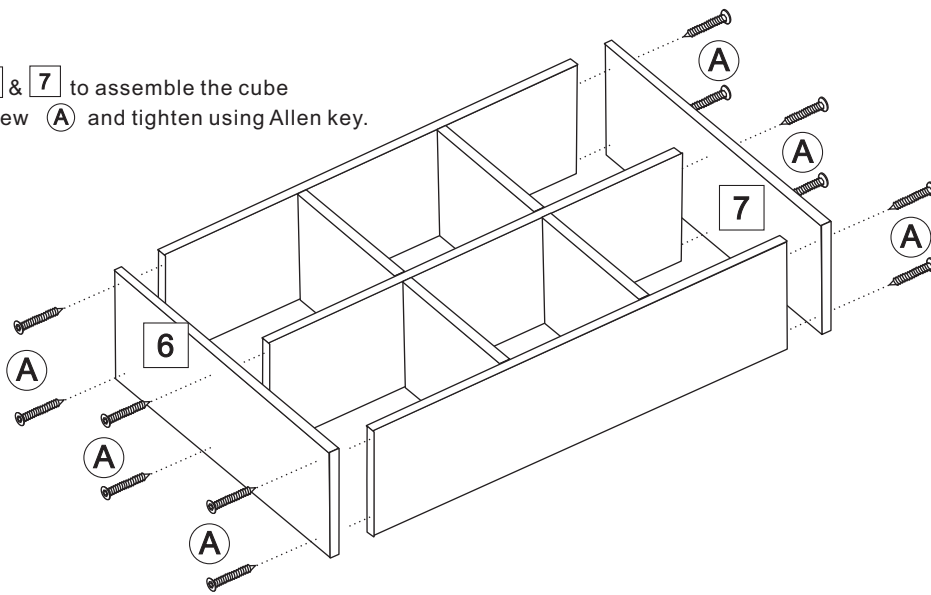

Step 3

3a. Fix the Back board 8 to the back, with Nail (D) using a small hammer.

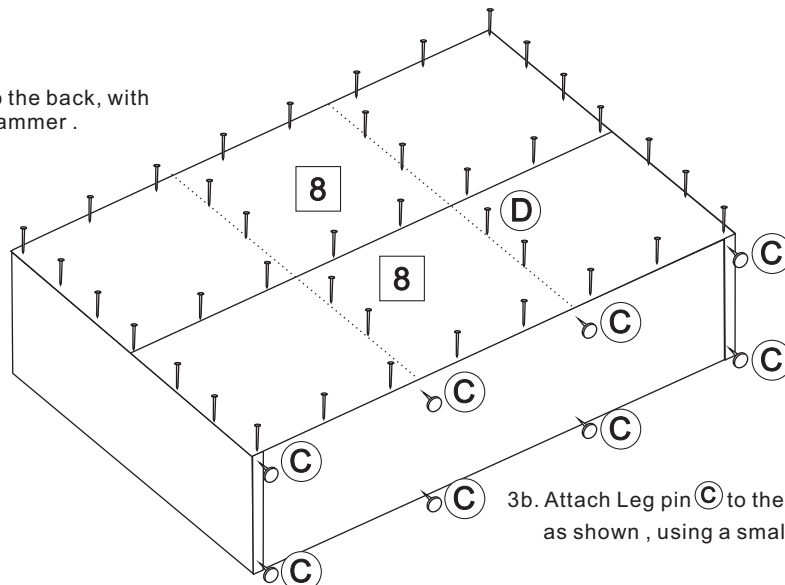

3b. Attach Leg pin (C) to the bottom panel as shown, using a small hammer.

Step 4

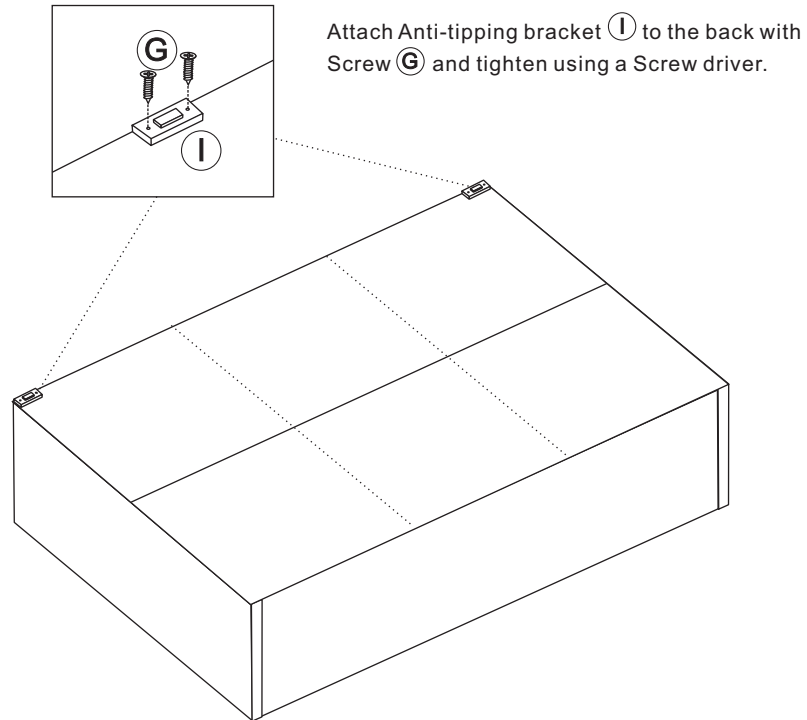

Step 5

Attach the Anti-tipping kit onto wall following the steps as shown.

